

SUPERBUTE™ JKW-200ER

OUTDOOR CURRENT TRANSFORMER

34.5 kV, 60 Hz
200 kV BIL



APPLICATIONS

Designed for outdoor service; suitable for operating meters, relays, and control devices. Features two independent cores; an extended range (ER) metering core with 0.15% accuracy from 1% of rated current to its rating factor (within burden capability), and a second core with both a relay class rating and a 0.15% metering accuracy rating from 5% of rated current to its rating factor. Available in a variety of ratios as outlined in the unit selection table below.

FEATURES

- Weight (Shipping/Unit): 438/403lbs
- Creep Distance: 56.61" [1438mm]
- 1sec Thermal Limit: 75x normal
- 2 cycle Mechanical Limit: 170x rated (low ratio)
- 2 cycle Mechanical Limit: 85x rated (high ratio)
- Insulation: HY-BUTE 60™ Butyl Rubber
- Insulation Class: 200kV BIL, Outdoor
- Design Standard: IEEE C57.13

BENEFITS

- Maximize revenue metering accuracy with special high accuracy rating extended beyond IEEE requirements
- Simplify CT selection and billing multipliers, improving productivity and minimizing risk of error
- Reduce inventory and part number requirements, reducing asset and operational costs



UNIT SELECTION

Two Tapped Secondaries

CATALOG NUMBER	RATIO (AMPS)	RATING FACTOR	EXTENDED RANGE METERING CORE X2-X3 ² / X1-X3 ¹	RELAY CORE Y2-Y3 / Y1-Y3	
				RELAY CLASS	IEEE METERING CLASS
757X038013	25/50:5//5	2.0 / 1.5	0.15 @ E-0.04 thru B-0.9 / 0.15 @ E-0.04 thru B-1.8	T200/T400	0.3 @ B-0.1 thru B-0.9 / 0.15 @ E-0.04 thru B-1.8
757X038012	50/100:5//5	2.0 / 1.5			
757X038011	75/150:5//5	2.0 / 1.5			
757X038010	100/200:5//5	2.0 / 1.5			
757X038009	150/300:5//5	2.0 / 1.5			
757X038008	200/400:5//5	2.0 / 1.5			
757X038007	300/600:5//5	2.0 / 1.5			0.3 @ B-0.1 thru B-0.5 / 0.15 @ E-0.04 thru B-1.8
757X038005	500/1000:5//5	2.0 / 1.5			
757X038004	600/1200:5//5	2.0 / 1.5			
757X038003	800/1600:5//5	2.0 / 1.5			
757X038002	1000/2000:5//5	2.0 / 1.5			
757X038001	1500/3000:5//5	1.5 / 1.33			
					0.15 @ E-0.04 thru B-1.8 / 0.15S @ E-0.04 thru B-1.8

Two Single Ratio Secondaries

CATALOG NUMBER	RATIO (AMPS)	RATING FACTOR	EXTENDED RANGE METERING CORE X1 - X2 ¹	RELAY CORE Y1-Y2		
				RELAY CLASS	IEEE METERING CLASS	
757X038113	50:5//5	1.5	0.15 @ E-0.04 thru B-1.8	T400	0.15 @ E-0.04 thru B-1.8	
757X038112	100:5//5	1.5				
757X038111	150:5//5	1.5				
757X038110	200:5//5	1.5				
757X038109	300:5//5	1.5				
757X038108	400:5//5	1.5				
757X038107	600:5//5	1.5				
757X038105	1000:5//5	1.5				
757X038104	1200:5//5	1.5				
757X038103	1600:5//5	1.5				0.15S @ E-0.04 thru B-1.8
757X038102	2000:5//5	1.5				
757X038101	3000:5//5	1.33				

¹ GE Revenue Sense exceeds IEEE std C57.13.6-2005 definition for high accuracy. Maintains 0.15 accuracy from 1% to rating factor.

APPLICABLE WIRING DIAGRAMS

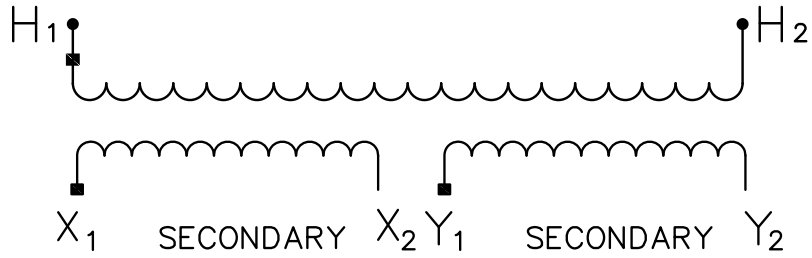
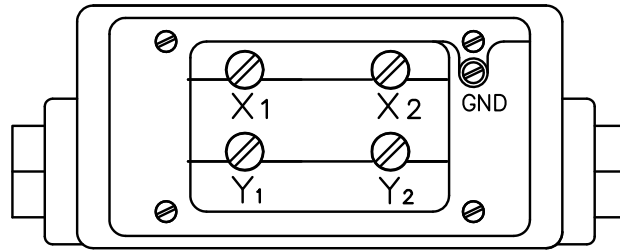

*Dual Secondary (default)
(Four secondary terminals)*

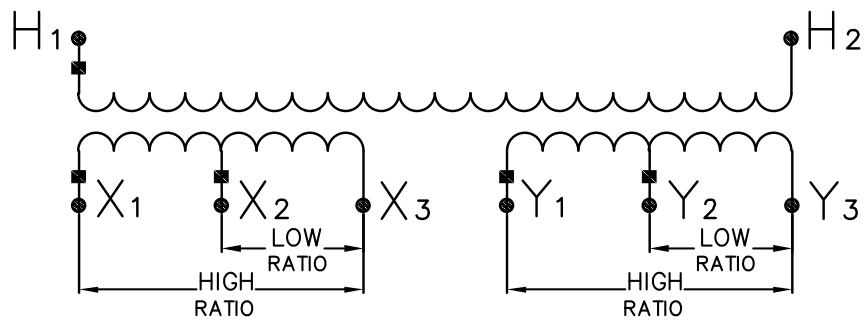
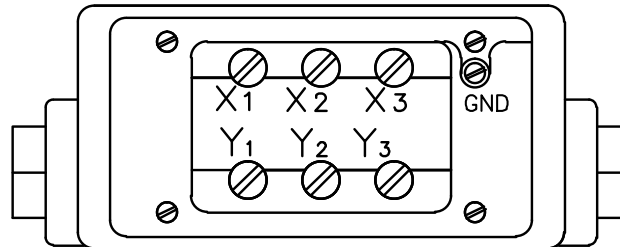

*Dual-tapped secondary
(Six secondary terminals)*

OUTLINE DIMENSIONS - UP TO AND INCLUDING 600A

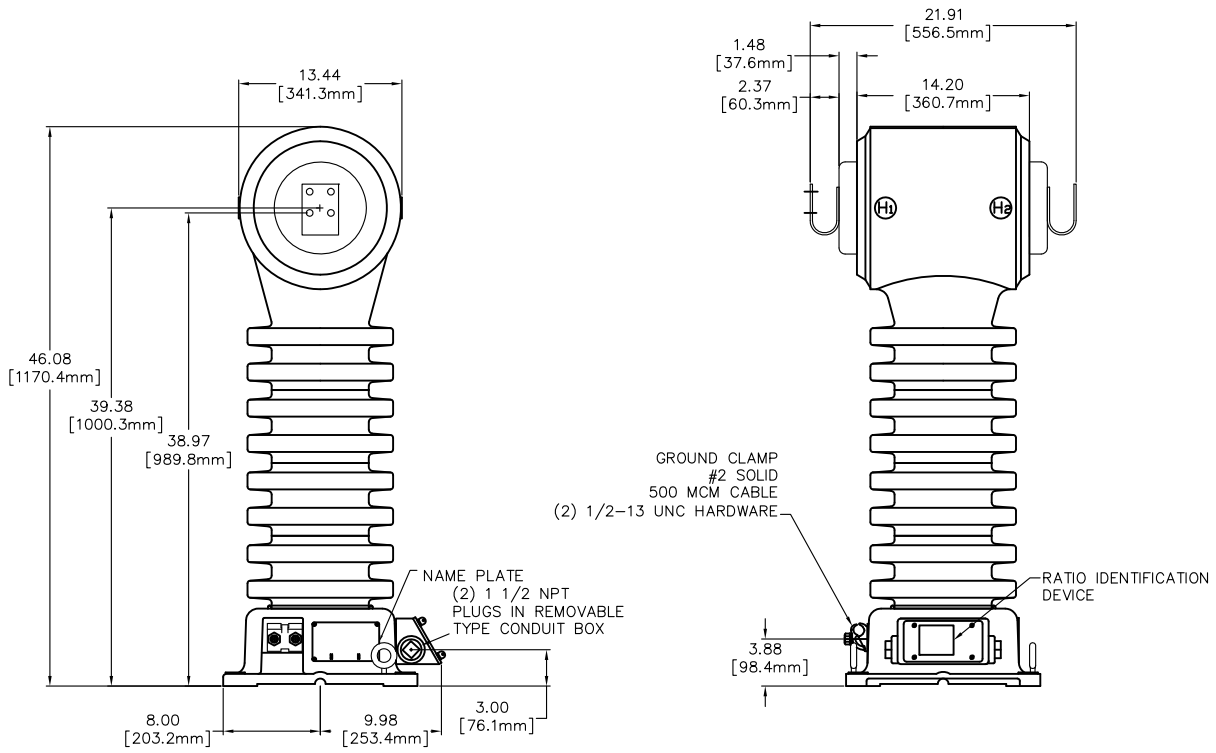

OUTLINE DIMENSIONS - ABOVE 600A

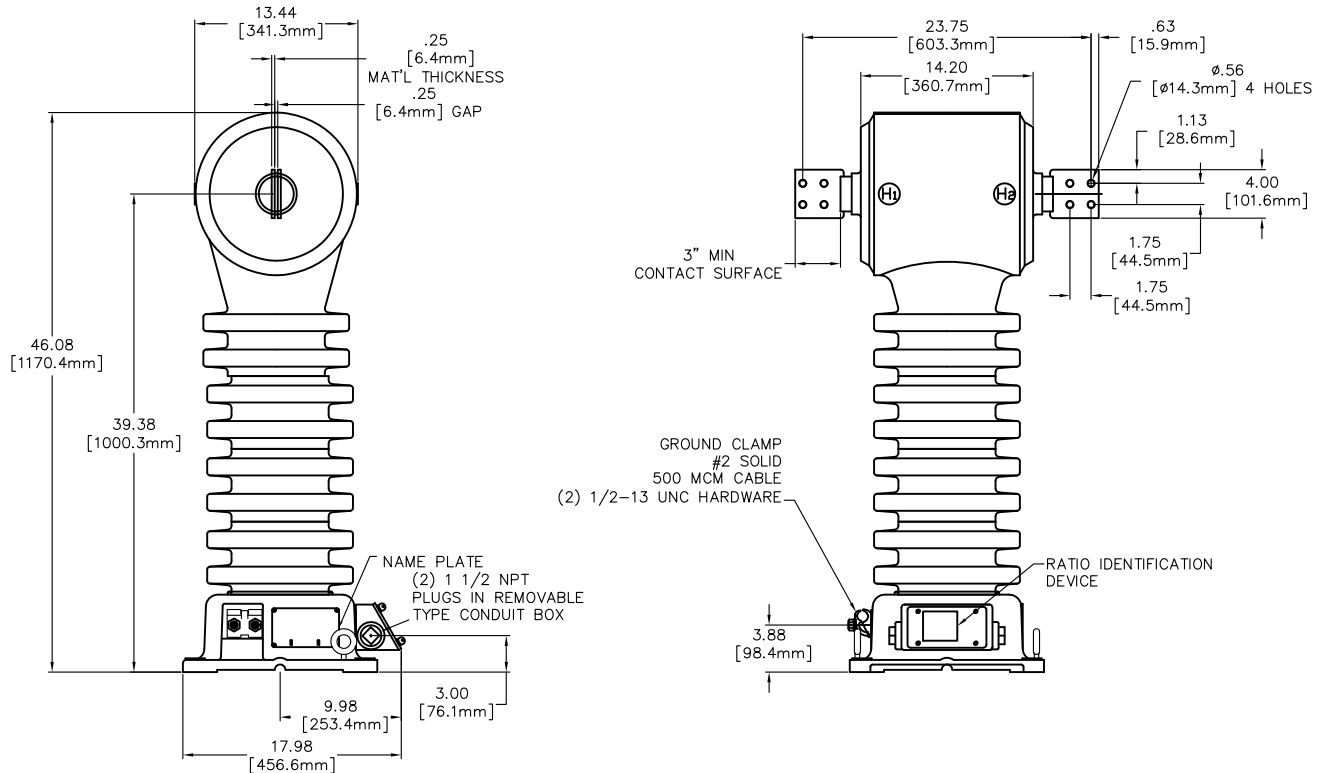

MOUNTING PLATE & PRIMARY TERMINAL CONFIGURATIONS

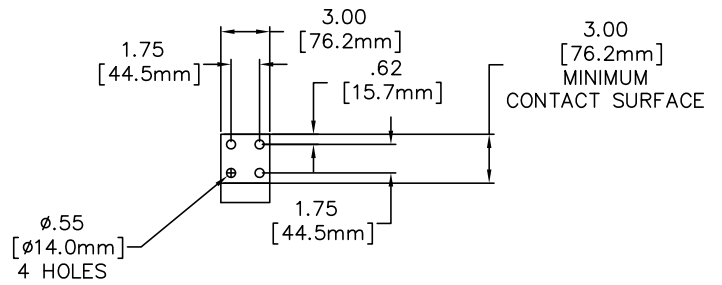
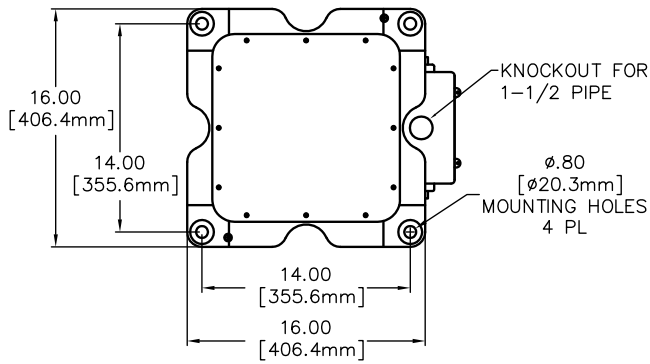

Primary - 1 PAD, up to 600A

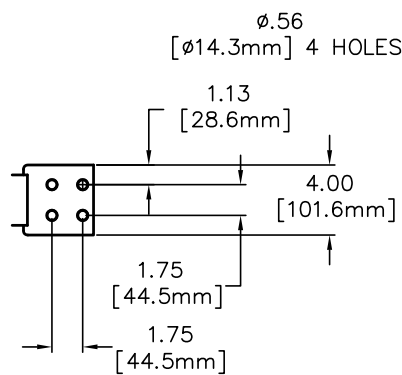

Primary - 1 and 2 PAD, up to 2000A

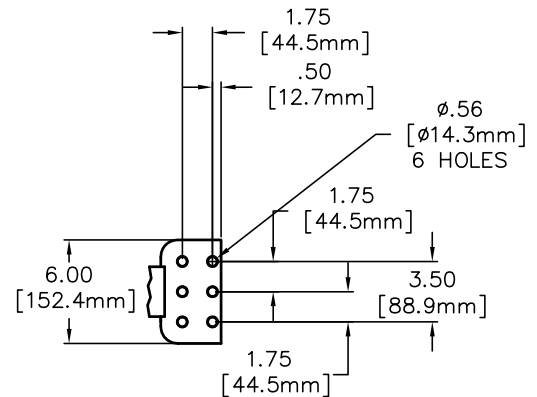

Primary - 3 PAD, up to 3000A

PAD CONFIGURATIONS - ABOVE 600:5A

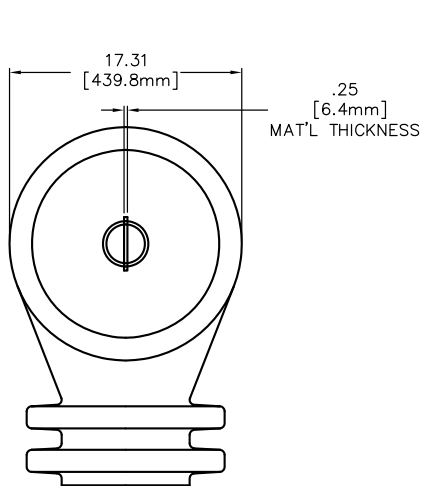

PAD CONFIGURATION FOR
800:5-1200:5
1 PAD EACH SIDE

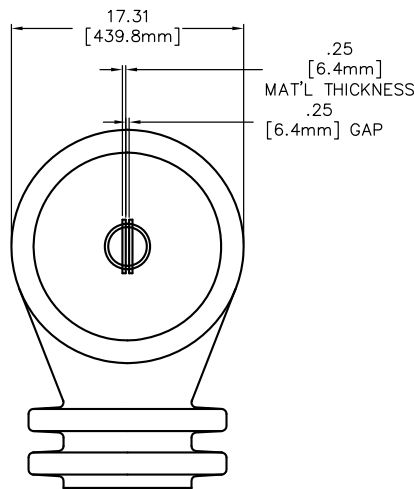

PAD CONFIGURATION FOR
1600-2000:5
2 PADS EACH SIDE

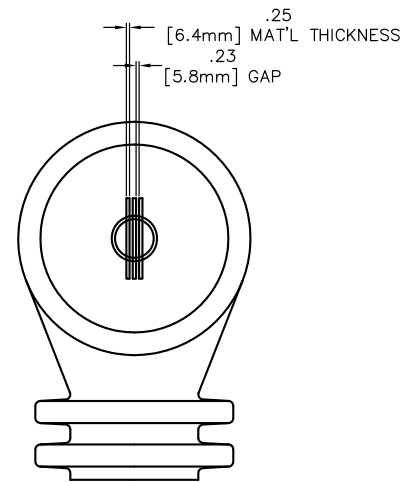

PAD CONFIGURATION FOR
3000:5
3 PADS EACH SIDE

CONSTRUCTION DETAILS

Insulation

The transformer design is constructed using GE's premium HY-BUTE 60™ molded butyl rubber insulation for the transformer body. First introduced in 1955, GE's unique formulation is non-arc tracking and resistant to heat, chemicals, ozone and ultraviolet. This tough, resilient insulating material has proven to be superior in handling mechanical, electrical and environmental extremes, when compared against other insulation designs such as porcelain, urethane or epoxy.

Core

The extended range high accuracy metering core is manufactured with high-efficiency material that reduces energy losses, allowing for higher accuracy over a wider range. The relaying/high accuracy core is made from high-quality, grain-oriented, low-loss, high permeability silicon steel which is carefully selected and tested under rigidly controlled factory conditions. The core is wound in the direction of the grain to take advantage of the high permeability.

Bushings

Since the bushings are an integral part of the transformer, standards normally pertaining to porcelain bushing tests do not apply. However, characteristics equal to, or better than, those required for porcelain are provided.

Primary Windings

The primary winding is mounted in the high-voltage bushing head shell, which results in a more efficient use of the core properties by permitting a symmetrical distribution of the winding turns. It keeps leakage to a minimum, and makes possible a high level of accuracy with fewer ampere-turns and corresponding improvement in thermal rating. In transformers rated 600:5 A and lower, a multi-turn primary winding is used, consisting of equally distributed copper conductors which encircle the core and secondary winding. In transformers rated 800:5 A and above, a single-turn, copper primary bar is used.

Primary Terminals

Transformers rated 600:5 Amperes and below have a U-shaped pad for the primary terminals. Transformers rated 800:5 Amperes and above use a vertically-oriented, flat copper bar for the primary terminal pads. In both cases, the terminal pads contain four mounting holes with industry standard hole sizes and spacing.

Secondary Winding

The secondary winding is wound with enamel-insulated copper conductor. All turns are evenly distributed around the core, and suitable compensation is used to obtain very high accuracy performance. The secondary leads extend downward through the bushing tube to the secondary terminal block in the transformer base.

Secondary Terminals

The secondary terminals are enclosed in a box secured to the base of the transformer with four, 1/4 -20 screws. Both the box and terminal block can be relocated to any of three sides of the base to fit the particular installation. The terminal box has 1½ inch threaded conduit openings at each end, and a 1½ inch knockout at the bottom. It is also provided with a grounding terminal for the secondary circuit, when required.

Testing

Rigorous GE test requirements go beyond IEEE routine requirements in order to ensure long term reliability. Test reports are saved electronically and can be e-mailed in various formats upon request.

Polarity

The permanently molded primary polarity markings H1 and H2 and the secondary polarity markings X1 and X2 are situated adjacent to their respective terminals. The polarity terminal is designated by use of the subscript 1, and the mark is painted white for better visibility.

Baseplate and Mounting

Transformers can be mounted in any position from upright to inverted, providing the centerline of current transformers through the primary terminals is parallel with the ground surface. Loading by lines or busswork should be kept to a minimum to avoid placing appreciable strain upon the transformer bushings and terminals. The maximum recommended loading from all sources should not be greater than the equivalent of a 200-pound external force applied at the axis of the primary terminals. A fabricated metal base is the supporting structure for the transformer. It is provided with four 13/16 inch mounting holes and two lifting eye- bolts. Adjacent to the nameplate is a standard two- bolt ground connector.

Nameplate

The nameplate is made of aluminum and located on the base of the transformer. Information is per IEEE designation, laser-engraved in easy-to-read form. Custom barcoding available upon request.

Maintenance

These transformers require no maintenance other than an occasional cleaning if installed in an area where air contamination is severe.

GE Grid Solutions

Toll Free : +1 877-605-6777

Direct: +1 678-844-6777

GE Grid Solutions

GE, the GE monogram, SUPERBUTE and HY-BUTE 60 are trademarks of the General Electric Company.

IEEE is a registered trademark of the Institute of Electrical Electronics Engineers, Inc.

GE reserves the right to make changes to specifications of products described at any time without notice and without obligation to notify any person of such changes.

Copyright 2020, General Electric Company. All Rights Reserved.

GEA-12937A
English
200921

