

# Model JAI-0C

**Indoor Current Transformer, 10 kV BIL, 50-800 A  
Window Diameter 2.06"/3.00"**



Model JAI-0C

## Application

Designed for indoor service. Suitable for use with indicating instruments and energy management systems. Due to their very low burden capability, these transformers are not normally used with watt-hour meters for revenue billing.

## Regulatory Agency Approvals

UL Recognized File .....E93779

## Rating Factor

1.0 @ 30 °C

## Weight

(approximate)

Transformer with 2.06" window .....0.6 lbs

Transformer with 3.00" window .....0.9 lbs

## Reference Drawings

Outlines

JAI-0C .....0121C33705

## Insulation Level

0.6 kV; Designed for use with insulated conductors.

## Frequency

50-60 Hz

## JAI-0C

Current Ratio (Amps) Pri : Sec	Operation at 60 Hz		Dimensions, in inches (See Outline Drawings)			Catalog Number
	Accuracy	Burden	Outside Dim. Ax B	Window Dia. C	Thickness D	JAI-0C
100:5	1%	1 VA @ 1.0 PF	3.43 X 3.74	2.06	1.10	750X193011
150:5	1%	2.5 VA @ 0.9 PF	3.43 X 3.74	2.06	1.10	750X193012
200:5	1%	4 VA @ 0.9 PF	3.43 X 3.74	2.06	1.10	750X193013
250:5	1%	6 VA @ 0.9 PF	3.43 X 3.74	2.06	1.10	750X193014
300:5	1%	7.5 VA @ 0.9 PF	3.43 X 3.74	2.06	1.10	750X193015
400:5	1%	10 VA @ 0.9 PF	3.43 X 3.74	2.06	1.10	750X193016
500:5	1%	12.5 VA @ 0.9 PF	3.43 X 3.74	2.06	1.10	750X193017
200:5	1%	5 VA @ 0.9 PF	4.50 X 4.88	3.00	1.10	750X193018
250:5	1%	5 VA @ 0.9 PF	4.50 X 4.88	3.00	1.10	750X193019
300:5	1%	6 VA @ 0.9 PF	4.50 X 4.88	3.00	1.10	750X193020
400:5	1%	10 VA @ 0.9 PF	4.50 X 4.88	3.00	1.10	750X193021
500:5	1%	10 VA @ 0.9 PF	4.50 X 4.88	3.00	1.10	750X193022
600:5	1%	10 VA @ 0.9 PF	4.50 X 4.88	3.00	1.10	750X193023
750:5	1%	10 VA @ 0.9 PF	4.50 X 4.88	3.00	1.10	750X193024
800:5	1%	12.5 VA @ 0.9 PF	4.50 X 4.88	3.00	1.10	750X193025



## Dimensions - Refer to Data Table

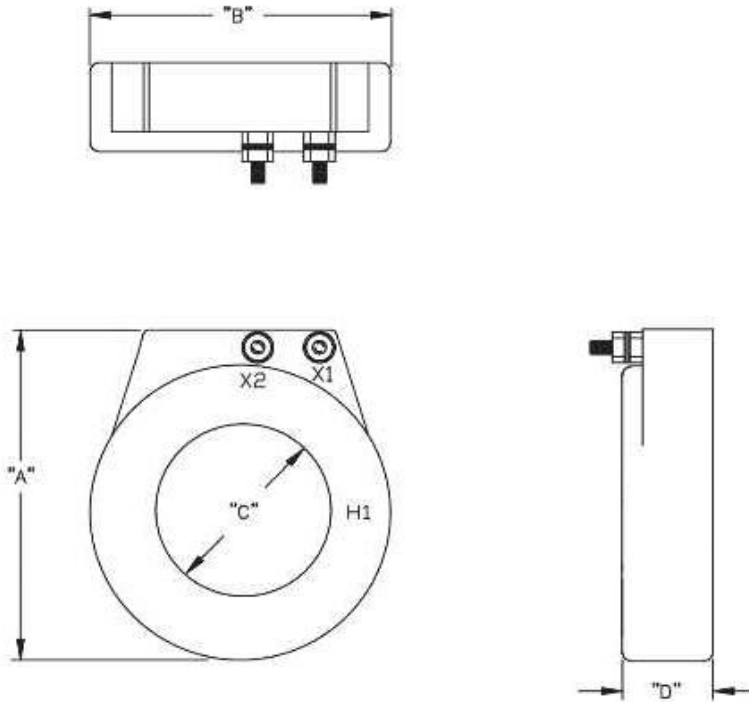

### Construction and Insulation

The core and coil are enclosed in a case molded with GE Noryl thermoplastic PPO resin. This material has excellent electrical and mechanical properties over a wide temperature range, low water absorption and is flame resistant.

### Core and Coils

The core is made from high quality grain oriented silicon steel, annealed under rigidly controlled factory conditions. The secondary winding is made of heavy enameled copper wire. The secondary windings are evenly distributed around the core for maximum accuracy and resistance to stray fields from adjacent conductors.

### Terminals

Secondary terminals on Model JAI-0C are No. 8-32 brass studs with one flat washer and one lock-washer and a regular nut.

### Polarity

The H1 polarity mark is molded into the case, at the side of the window on one face. The X1, X2 polarity marks are also molded into the case adjacent to the secondary terminals.

### Primary Conductor

These units are designed to be placed over an insulated cable which forms the primary winding.

### Nameplates

The nameplate is a polyester label attached to the side of the transformer.

### Mounting

The transformer can be mounted in any position. And, may be suspended from the bus-bar or cable.

### Maintenance

These transformers require no maintenance, other than occasional cleaning, if installed where air contamination is severe.

### [GEGridSolutions.com](http://GEGridSolutions.com)

Grid-AIS-L4-ITL\_Model\_JAI\_0C-1388-2017\_07-EN. © Copyright 2017. General Electric Company and Instrument Transformers LLC reserve the right to change specifications of described products at any time without notice and without obligation to notify any person of such changes.

### Worldwide Contact Center

Web: [www.GEGridSolutions.com/contact](http://www.GEGridSolutions.com/contact)

Phone: +44 (0) 1785 250 070

USA and Canada: +1 (0) 800 547 8629

Europe, Middle East and Africa: +34 (0) 94 485 88 00

