



## Type BO7 Outdoor Slip-Over BCT's

Solution for adding current sensing to new and existing outdoor substations.

### APPLICATIONS

---

- Add CT's to outdoor power transformers, breakers, and cable termination devices
- Replace existing substation CT's
- Install over high voltage bushings through 800 kV
- Add metering points for "Smart Grid" control and communications
- Increase degree of system protection
- Increase CT accuracy
- Change CT ratio
- CT installation with minimal substation downtime

### FEATURES

---

- Custom & standard designs available
- Designs for metering and protection applications
- Meet IEEE 57.13 and IEC 60044-1 standards
- Standard 0.3% and high accuracy 0.15% ratings available for metering applications
- Corrosion resistant mounting hardware kits
- Corrosion resistant termination box
- Aluminum nameplate
- Optional ground shields available

# Construction

The toroidal cores are made of cold-rolled, high-permeability, grain-oriented, silicon steel, annealed after forming under precisely controlled conditions. The grain of the core steel is oriented in the direction of the magnetic flux, thus minimizing the core losses and maximizing the accuracy.

## Windings

The windings are wound over the insulated core on large toroidal winding machines. They are fully distributed around the core on all taps so that the leakage reactance is low on each tap.

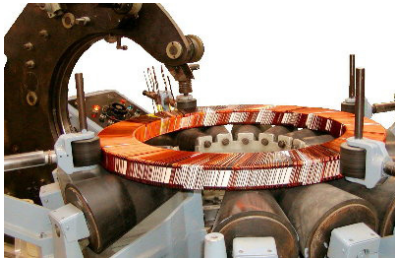

## Encapsulation

The core and coils are encapsulated in polyurethane. The system used is a proprietary formulation. It was developed specifically to meet the rigorous electrical, physical and chemical requirements of outdoor, electrical insulation.

This encapsulation system demonstrates excellent weather resistance. The U.V.-stabilized insulation has adequate elasticity to compensate for dimensional changes of the core caused by temperature variations without cracking or crazing.

## Secondary Terminals and Conduit Box

The secondary terminals are #10-32 screws housed in a corrosion resistant and weather proof conduit termination box with cover and gasket.

The box is fitted with two 1" NPT threaded openings for horizontal conduit takeoff. The flange for the cover is at a 45 degree angle which gives maximum accessibility for wiring and connecting.

## Ground Shield

Ground shields are available. The ground shields are fabricated of aluminum and fit closely over the top of the current transformer. The purpose of the shield is to prevent a bushing flash-over from penetrating the CT insulation and impressing a high voltage upon the secondary winding, interconnecting cables, and relays.

In an installation where it is desirable for the CT to "see" the bushing flash-over current, the mounting clamps should be positioned around the inner periphery and the ground conductors should pass through the window. The inside diameter of the current transformer should be increased by 4" to accommodate this arrangement. (Figure 2A)

In an installation where it is not desirable for the CT to "see" a bushing flash-over, the mounting clamps should be placed around the outer periphery of the transformer and the ground conductor should not pass through the window. (Fig 2B)

## Mounting Clamps

The mounting clamps are aluminum and held together with continuously threaded 1/2" stainless steel studs and stainless steel nuts. Mounting clamps also support an optional ground shield. Clamps can be placed at any convenient location around the inner or outer periphery of the transformer. Three complete sets are included with each transformer. (Figures 2A and 2B)

## Standard Multi-Ratio Secondary Taps

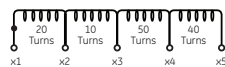

Nominal Ratio - 600:5

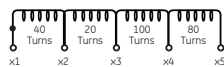

Nominal Ratio - 1200:5

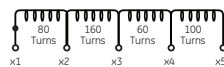

Nominal Ratio - 2000:5

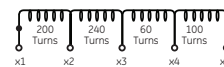

Nominal Ratio - 3000:5

Ratio	Secondary Taps	Ratio	Secondary Taps	Ratio	Secondary Taps	Ratio	Secondary Taps
600:5	X1-X5	1200:5	X1-X5	2000:5	X1-X5	3000:5	X1-X5
500:5	X2-X5	1000:5	X2-X5	1600:5	X2-X5	2500:5	X1-X4
450:5	X3-X5	900:5	X3-X5	1500:5	X1-X4	2200:5	X1-X3
400:5	X1-X4	800:5	X1-X4	1200:5	X1-X3	2000:5	X2-X5
300:5	X2-X4	600:5	X2-X4	1100:5	X2-X4	1500:5	X2-X4
250:5	X3-X4	500:5	X3-X4	800:5	X2-X3	1200:5	X2-X3
200:5	X4-X5	400:5	X4-X5	500:5	X4-X5	1000:5	X1-X2
150:5	X1-X3	300:5	X1-X3	400:5	X1-X2	800:5	X3-X5
100:5	X1-X2	200:5	X1-X2	300:5	X3-X4	500:5	X4-X5
50:5	X2-X3	100:5	X2-X3			300:5	X3-X4

## Type B07 - Current Transformer Standard Selection

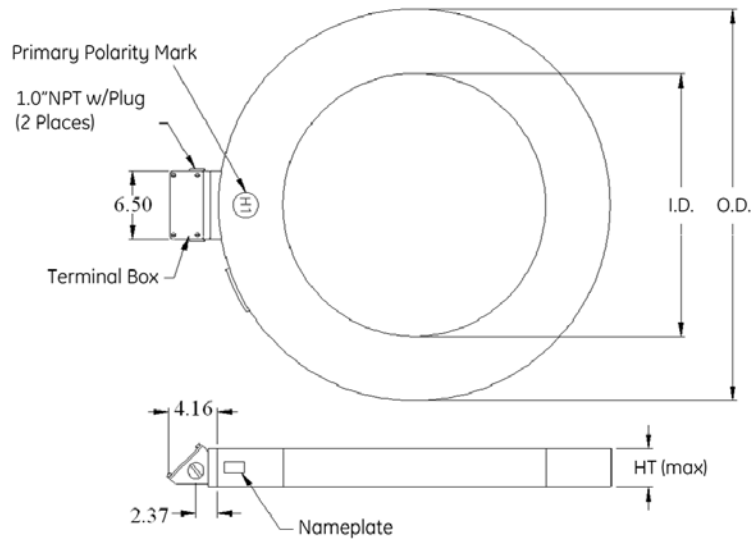

Catalog Number	Ratio	Relaying Accuracy	ID (Inches)	OD (Inches)	HT (max) (Inches)	Approx. Weight
B07-601-12	600:5MR	C400	12.00	24.75	4.50	245 lbs.
B07-601-18	600:5MR	C400	18.00	31.00	4.50	340 lbs.
B07-601-20	600:5MR	C400	20.00	33.00	4.25	355 lbs.
B07-601-22	600:5MR	C400	22.00	35.00	4.25	385 lbs.
B07-601-26	600:5MR	C400	26.00	39.00	4.25	425 lbs.
B07-601-28	600:5MR	C400	28.00	40.75	4.25	450 lbs.
B07-601-32	600:5MR	C400	32.00	43.50	5.00	475 lbs.
B07-122-12	1200:5MR	C800	12.00	24.75	4.50	233 lbs.
B07-122-18	1200:5MR	C800	18.00	30.75	4.50	307 lbs.
B07-122-20	1200:5MR	C800	20.00	32.75	4.50	331 lbs.
B07-122-22	1200:5MR	C800	22.00	34.75	4.50	356 lbs.
B07-122-26	1200:5MR	C800	26.00	38.75	4.50	406 lbs.
B07-122-28	1200:5MR	C800	28.00	40.75	4.50	429 lbs.
B07-122-32	1200:5MR	C800	32.00	43.50	4.75	460 lbs.
B07-202-12	2000:5MR	C800	12.00	24.75	3.75	200 lbs.
B07-202-18	2000:5MR	C800	18.00	30.75	3.75	240 lbs.
B07-202-20	2000:5MR	C800	20.00	32.75	3.75	255 lbs.
B07-202-22	2000:5MR	C800	22.00	31.00	3.75	275 lbs.
B07-202-26	2000:5MR	C800	26.00	38.75	3.75	315 lbs.
B07-202-28	2000:5MR	C800	28.00	40.75	3.75	325 lbs.
B07-202-32	2000:5MR	C800	32.00	43.50	3.75	355 lbs.
B07-302-12	3000:5MR	C800	12.00	24.75	3.75	144 lbs.
B07-302-18	3000:5MR	C800	18.00	30.75	3.75	189 lbs.
B07-302-20	3000:5MR	C800	20.00	32.75	3.75	202 lbs.
B07-302-22	3000:5MR	C800	22.00	34.75	3.75	215 lbs.
B07-302-26	3000:5MR	C800	26.00	38.75	3.75	243 lbs.
B07-302-28	3000:5MR	C800	28.00	40.75	3.75	257 lbs.
B07-302-32	3000:5MR	C800	32.00	43.50	3.75	268 lbs.

\* Consult factory for other dimensions and ratings-including standard and high accuracy metering applications

\*\* All dimensions +/- 0.25 inches

# Installation

Note: All Dimensions on This Page Shown in Inches.

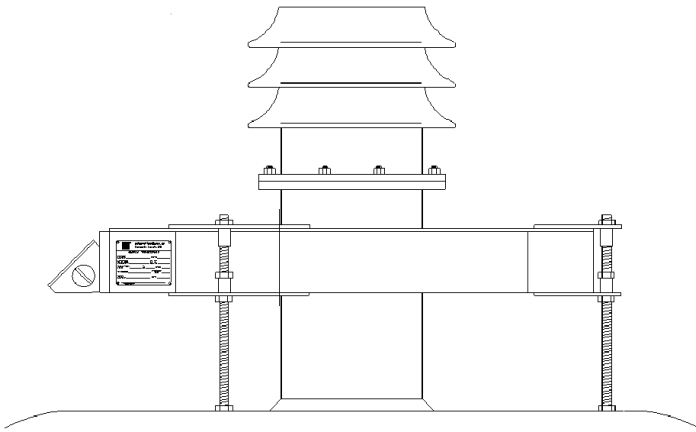

**Figure 1.**  
Slip-over cast resin BCT installed over outdoor bushing  
Note - BCT to be installed below ground plane

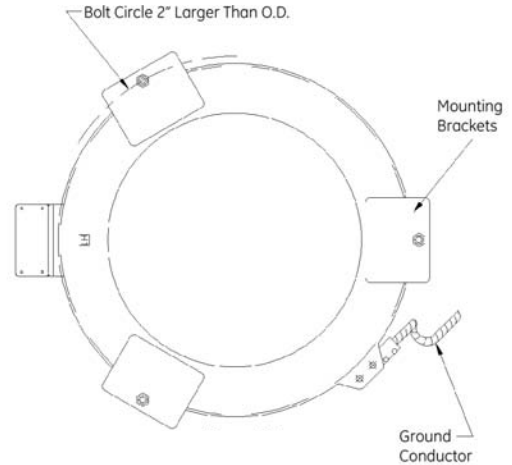

**Figure 2B.**  
Mounting bracket arrangement for not sensing bushing to ground flashover

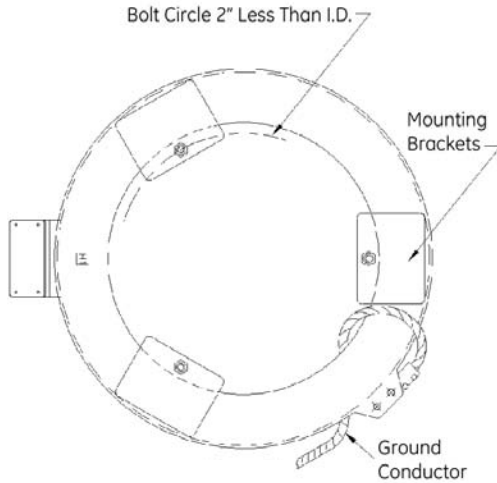

**Figure 2A.**  
Mounting bracket arrangement for sensing bushing to ground flashover

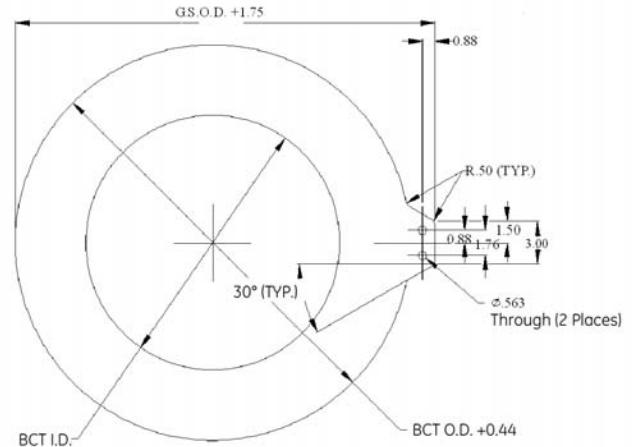

**Figure 3.**  
Ground shield (G.S.)

## Specification Requirements

- |                             |  |  |
|-----------------------------|--|--|
| 1) Minimum Inside Diameter  | 4) Ratio (Single, Dual or Multi-ratio) | 7) Rating Factor                                     |
| 2) Maximum Outside Diameter | 5) Accuracy Requirements               | 8) Frequency   |
| 3) Maximum Height allowed   | 6) Burden Requirements                 | 9) Any other mechanical or environmental limitations |

## Power Sensing - ITI

### Global Office

T (727) 298-2000  
F (727) 298-2087  
E gemultilin@ge.com

1907 Calumet St.  
Clearwater, FL 33765, USA

### European Office

T +34 94 485 88 00  
F +34 94 485 88 45  
E salesbilbao@ge.com

Avenida Pinoa 10-48170  
Zamudio (Vizcaya), Spain

### Asia Office

T +8621 3877 3808  
F +8621 3877 7459

No. 1 Hua Tuo Road,  
Zhangjiang Hi-Tech Park,  
Pudong District,  
Shanghai 201203, China