



INSTRUCTION MANUAL

English

First Release				Modification				Revision
Prepared by	Date	Approved by	Control	Checked by:	Date	Approved by	Control	03
MRM	30-05-17	RCC	RCC	AFR	01-05-18	TCRP	RCC	

©COPYRIGHT 2017 GE ENERGY (USA), LLC AND/OR ITS AFFILIATES. All rights reserved. The information contained herein is GE Grid Solutions Proprietary Technical Information that belongs to the General Electric Company, GRID SOLUTIONS (BRAZIL), LLC and/or their affiliates, which has been provided solely for the express reason of restricted private use. All persons, firms, or corporations who receive such information shall be deemed by the act of their receiving the same to have agreed to make no duplication, or other disclosure, or use whatsoever for any, or all such information except as expressly authorized in writing by the General Electric Company, GRID SOLUTIONS (BRAZIL), LLC and/or its affiliates.



INDEX

- 1 INTRODUCTION 5**
- 1.1 MAIN COMPONENTS5**
- 2 COIL 6**
- 2.1 COIL CONSTRUCTION6**
- 2.2 MAJOR COIL COMPONENTS6**
- 3 TUNING DEVICE..... 7**
- 3.1 CHANGING THE OPERATING FREQUENCY RANGE9**
 - 3.1.1 SAWB/SASF DEVICES9
 - 3.1.2 0.265 mH INDUCTANCE DEVICES9
- 4 TRANSPORTATION, RECEIVING, UNPACKING, STORAGE 10**
- 4.1 TRANSPORT10**
- 4.2 RECEIVING10**
- 4.3 STORAGE.....11**
- 4.4 UNPACKING.....11**
 - 4.4.1 VERTICALLY-CARRIED COILS12
 - 4.4.2 HORIZONTALLY-CARRIED COILS13
 - 4.4.3 UNPACKING INSPECTION14
- 5 COIL LIFTING 14**
- 5.1 OSD COIL LIFTING.....15**
 - 5.1.1 MOUNTING: VERTICAL/SUSPENSION MOUNTING (CARRYING: VERTICALLY)15
 - 5.1.2 MOUNTING: HORIZONTAL (CARRYING: HORIZONTALLY).....16
 - 5.1.3 MOUNTING: VERTICAL/SUSPENSION MOUNTING (CARRYING: HORIZONTALLY)16
- 5.2 MCD COIL LIFTING19**
- 6 LINE TRAP MOUNTING 21**
- 6.1 CONNECTING THE LINE TRAP TO THE TRANSMISSION LINE21**
- 6.2 ELECTRICAL CONNECTIONS21**
- 6.3 SCREW TIGHTENING TORQUE22**
- 6.4 - Line Traps connections23**
 - 6.4.1 – Assembly on CVT23



6.4.2 – Assembly on 1 or more post insulators23
6.4.3 – Suspended assembly on insulators string.....24

7 COMMISSIONING 25

8 MAINTENANCE 25

8.1 GENERAL INFORMATION AND MAINTENANCE PROGRAM25

8.2 PREVENTIVE & PREDICTIVE MAINTENANCE26

8.2.1 PROCEDURES26

8.3 PAINT27

8.3.1 PAINT RESTORING27

9 ENVIRONMENTAL EFFECTS..... 28

10 APPENDICES 29

10.1 REMOVING/INSTALLING BIRD BARRIERS29

10.2 REMOVING/INSTALLING THE TUNING DEVICE30



LINE TRAP AND ITS ACCESSORIES, INCLUDING SUPPORT STRUCTURE, SHALL BE CONSIDERED AS LIVE PARTS AFTER THE ENERGIZATION.

ANY PERSON INVOLVED WITH TRANSPORT, INSTALLATION, OPERATION AND MAINTENANCE OF THE LINE TRAP SHALL READ THIS INSTRUCTION MANUAL PRIOR TO HANDLE THE EQUIPMENT.



1 INTRODUCTION

GE has extensive experience in design and supply of Line Traps for power transmission systems up to 800 kV.

These operating instructions apply to MCD/OSD coil design manufactured by GE.

Line Traps consist of a coil, a tuning device and a lightning arrester for the tuning device protection.

1.1 MAIN COMPONENTS

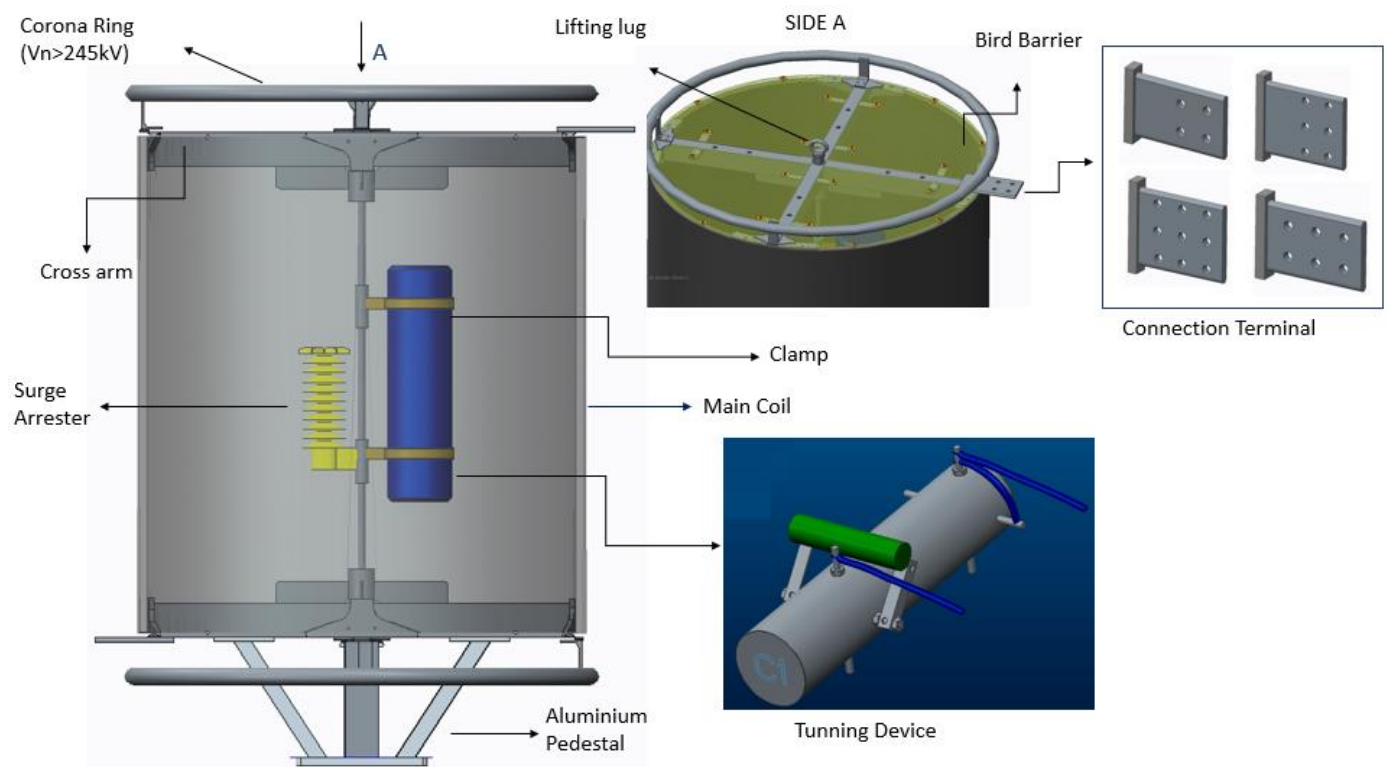

Note: All line traps are provided with bird barriers





2 COIL

The Line Trap coil consists of the main winding designed to withstand the rated, dynamic and thermal short-circuit currents of the transmission line, indicated on the equipment nameplate.

2.1 COIL CONSTRUCTION

This manual covers Lines Traps with MCD/OSD coil design.

Multi-Wire Cable Design (MCD)

In the MCD coil design, the winding consists of several conductors (wires or cables) connected in parallel forming cylinder shapes. Each conductor is isolated by helically wrapped insulating film, and conductors of the same cylinder are mechanically immobilized and encapsulated in epoxy impregnated fiberglass filaments. According to the coil specifications, one or more cylinders are connected in parallel through their cross arms where the winding input and output terminals are placed. The cylinders are separated by fiberglass spacers forming cooling ducts.

Open Style Design (OSD)

In the OSD design, the coil winding consists of aluminum profiles of rectangular cross section. These profiles are sized to withstand the current ratings of each application, and they are evenly separated by high mechanical strength fiberglass spacers. The two aluminum cross arms are held together at the ends of the windings by one or more insulated fiberglass reinforced rods. All materials used are compatible with the insulation class of the equipment.

2.2 MAJOR COIL COMPONENTS

Cross arms: they are made of flat round-edge aluminum bars, held together to an aluminum profile called spider (MCD Design). In the OSD Design, the cross arms are made of aluminum tube.

Lightning Arrester: It protects the line trap from transient overvoltages in the transmission line, but it will not operate as a result of overvoltages due to the dynamic and thermal short-circuit currents. The lightning arrester is connected in parallel with the Tuning Device, with aluminum or copper cables through the central rod of the coil (Refer to the figure in subsection 1.1).

Connection terminal: equipment electrical terminals, usually a cross arm extension, with hole patterns and orientations to meet the customer needs.

Pedestal mounting: They are directly mounted on to the base/structure intended for the equipment installation.



3 TUNING DEVICE

Tuning devices are factory-set by GE, and connected directly to the main coil (top and bottom cross arms) requiring no additional connection during field mounting. The damping resistor, if required, is mounted outside the device. It is mounted on the line trap's central rod, between the top and bottom cross arms by insulating polycarbonate or fiberglass clamps as shown in the figure of subsection 1.1.

GE tuning devices are designed for easy access either for frequency adjusting or the tuning device replacement, according to the coil specifications or to meet specific customer needs. It can be replaced without removing the main coil from the transmission line (refer to subsection 10.2 for removal details of the tuning device).

The tuning device components are encapsulated in weather-protection housing to resist environmental conditions and mechanical shocks. The temperature coefficient of tuning device elements are chosen to yield a high degree of tuning stability, also ensuring exceptional operating reliability and a long service life.

GE tuning devices may be used in line traps of other brands, as their rated characteristics are compatible. So they are sometimes sold separately.

Tuning devices support a fixed or field-adjustable frequency range so they can be designed for single, dual, or wide band tuning.

The table below shows the range of GE line trap sets, including the tuning device and their design type compatibility.



Device type	Description	Technology	Tunning Range	Additional Manual
FWB	Fixed Wide Band	OSD / MCD	*Defined by client	N / A
FSF	Fixed Single Frequency	OSD / MCD	*Defined by client	N / A
FDF	Fixed Double Frequency	OSD / MCD	*Defined by client	N / A
SAWB	Adjustable Wide Frequency	OSD / MCD	*Defined by client	N / A
SASF	Adjustable Single Frequency	OSD / MCD	*Defined by client	N / A

Device type	Description	Technology	Tunning Range	Additional Manual
ASF	Adjustable Single Frequency (Especific to 0.265mH inductance)	OSD	30-90 kHz	14196
		OSD	50-150 kHz	13774
		OSD	70-200 kHz	13812
		OSD	90-300 kHz	13038
ADF	Adjustable Double Frequency (Especific to 0.265mH inductance)	OSD	30-90 kHz	18099
		OSD	50-150 kHz	17481
		OSD	70-200 kHz	13842
		OSD	90-300 kHz	14220
AWB	Adjustable Wide Frequency (Especific to 0.265mH inductance)	OSD	50-205 kHz	15042
		OSD	90-300 kHz	15150

FWB / FSF / FDF devices are designed for fixed frequency bands. They are factory preset according to the customer specification. The tuning device servicing by customer is usually for maintenance or replacement of the unit. (Refer to subsection 10.2 for removal directions of the tuning device).

SAWB / SASF devices are designed so that a large user-defined bandwidth is subdivided into smaller frequency bands (adjustable devices). The device operating range is field selected by customer. Factory preset tuning of these devices is made by GE according to the sub band defined in the customer-approved dimensional drawing.

Tuning devices for 0.265 mH line traps have specific tuning manuals, which are always sent to the end customer together with this general instruction manual. Factory preset of these tuning devices is done by GE according to the customer specification.



3.1 CHANGING THE OPERATING FREQUENCY RANGE

This operation applies to tunable devices only. Before changing the frequency range, bird barriers should be removed according to the procedure provided in subsection 10.1.

3.1.1 SAWB/SASF DEVICES

Once the bird barrier quadrant(s) for frequency tuning are removed, place the jumper in the desired operating frequency sub band.

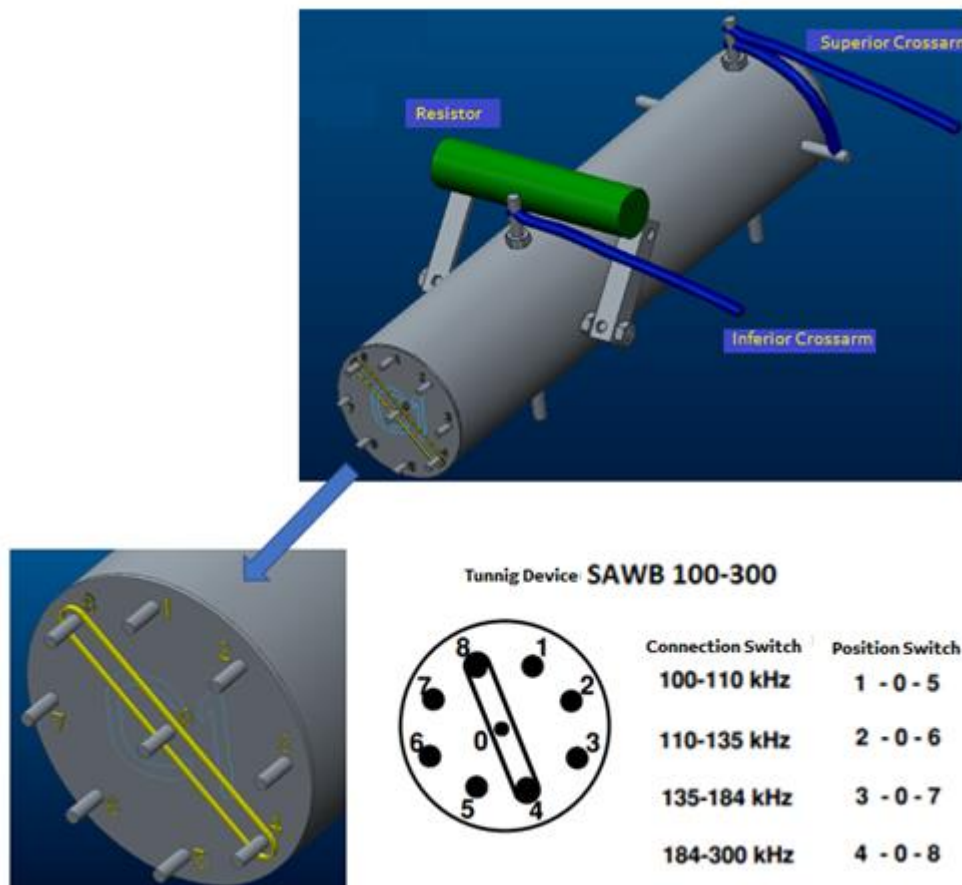

3.1.2 0.265 mH INDUCTANCE DEVICES

Once the bird barriers are removed, follow the device-specific manual directions for setting the equivalent capacitance in order to obtain the desired operating range. These settings are made by changing the jumper positions in the device tuning box.

If the tuning device does not have a tuning box, the rod connections should be changed per the specific tuning device manual.

NOTE: Once the desired tuning device settings are completed, reinstall the bird barriers as set out in subsection 10.1.



4 TRANSPORTATION, RECEIVING, UNPACKING, STORAGE

4.1 TRANSPORT

GE line traps are shipped in properly crafted wooden boxes/crates suitable for transport by land, air or sea according to major international regulations.

Each package usually contains a single equipment unit, eventually aluminum pedestals, porcelain insulators or other fitting accessories are included.

Notes:

- **The “Receiving Procedures” section provides directions in case of accidents or visible damage to the package or line trap during transportation.**
- **Stacking boxes for transport or storage is not recommended, unless prior authorization by GE.**

4.2 RECEIVING

The receiving staff should inspect the line traps upon receiving according to the following procedures:

- 1) Check the packaging conditions before discharging, if possible;
 - 2) If damage is found in one or more packages:
 - a) Report the damage to the vehicle’s driver, asking about incidents during transportation;
 - b) State at least the following information on the Bill of Lading: Package number and/or the equipment serial number, description of damage, and the driver’s report;
 - c) Take pictures of all damages, showing clearly the package number(s) and/or the equipment serial number(s);
- **If the transportation is the customer's responsibility:**
 - Contact the insurance company and follow their instructions;
 - Report GE and wait for their technical instructions about the damaged cargo. Open the packages upon GE's authorization only.
 - **If the transportation is the GE's responsibility:**
 - Report GE immediately and keep the packages as received so they can be inspected and evaluated as necessary;
 - Wait for technical instructions about the damaged cargo. Open the packages upon GE's authorization only.



4.3 STORAGE

The line trap storage should follow the instructions below:

- **Indoors:**

In non-corrosive sheltered environments, line traps should be stored in their own packaging, on a flat floor with capacity to support the full package weight.

- **Outdoors:**

The recommended maximum outdoor shelf life within the package is two (2) months (may vary depending on weather conditions). For a longer period, the line trap should be removed from the wooden crate and placed on its own pallet or wooden shims. Weather resistant packaging may be requested for quoting to GE's sales department.

- Stacking boxes for transport or storage is not recommended, unless prior authorization by GE



4.4 UNPACKING

Before unpacking the equipment it is essential to check its lifting conditions, as set out in section 5.

Make sure that all accessories are removed from the equipment before power up.

The staff in charge for unpacking the equipment should follow the procedures below:



4.4.1 VERTICALLY-CARRIED COILS

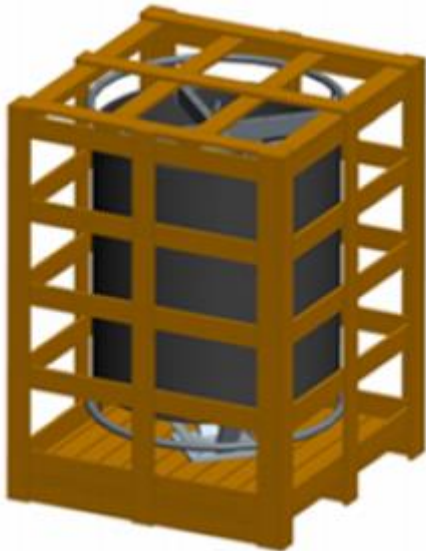

Place the line trap package on a flat floor.



Remove the top cover by removing the ribbons and metal plates from the package sides.



Remove the side panels and wooden latches



Remove the screws, ribbons and other fittings attaching the Line Trap to the pallet, before taking it out from the pallet.

- Refer to subsection 5.1.1 for the equipment lifting instructions.





4.4.2 HORIZONTALLY-CARRIED COILS

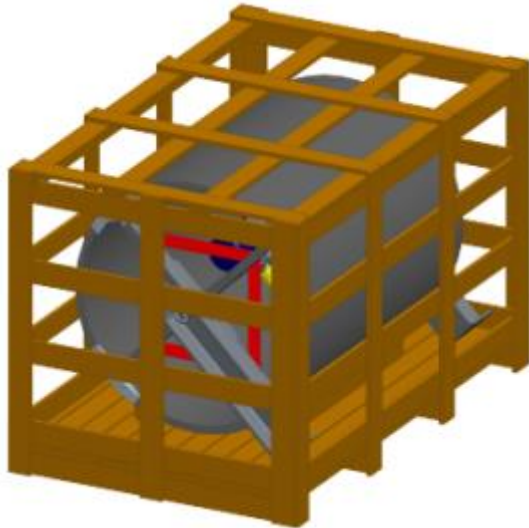

Place the line trap package on a flat floor

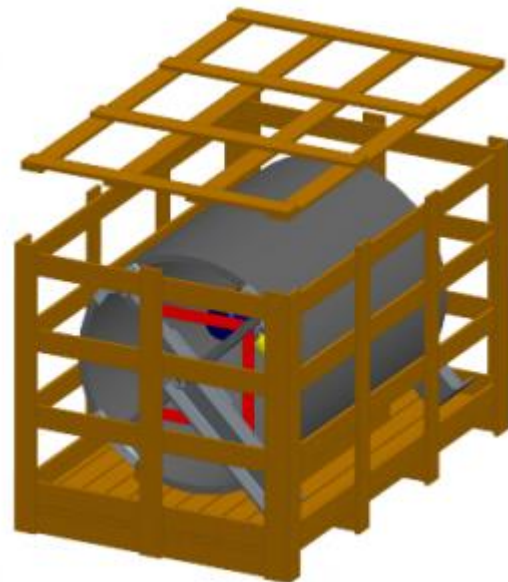

Remove the top cover by removing the ribbons and metal plates from the package sides

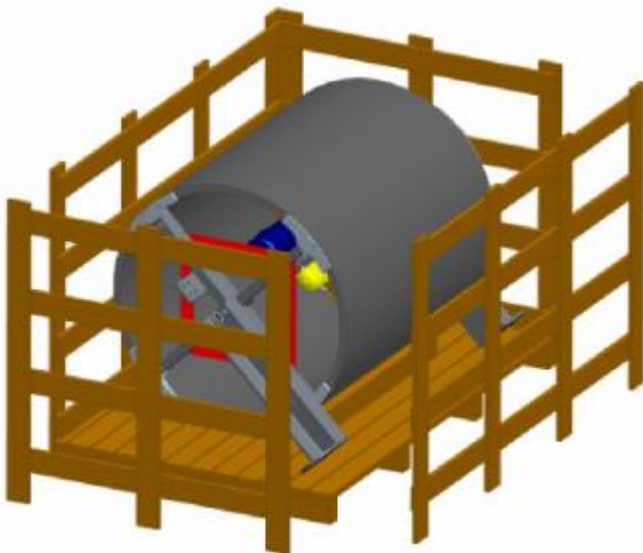

Remove the side panels and wooden latches

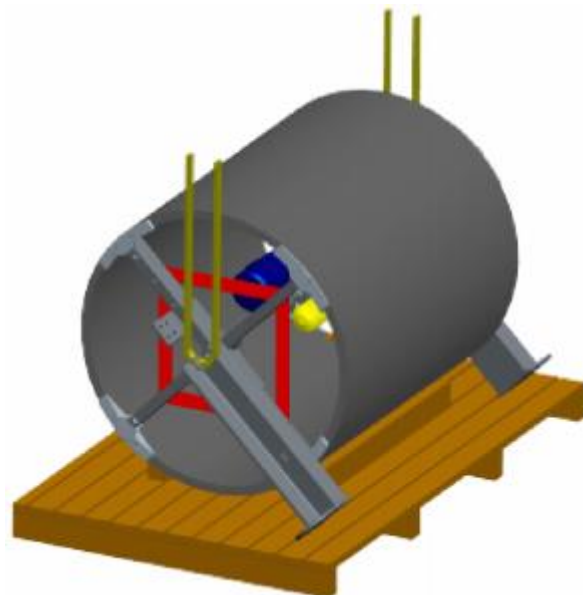

Remove the screws, ribbons and other fittings attaching the Line Trap to the pallet, before taking it out from the pallet.

- Refer to subsection 5.1.2 for the equipment lifting instructions.





4.4.3 UNPACKING INSPECTION

After unpacking, the line trap should be carefully inspected as follows:

- 1) Check if the package contents conform to the Invoice's description;

NOTE: The customer should report GE immediately if the content received is different from the invoice's description or some components in the GE's supply are missing.

- 2) Check all ties (between cross arms and vertical rods), if any.
- 3) Check for damage on the line trap's encapsulation surface (MCD type).
- 4) In case of damage:
 - a) Take pictures of all damages, showing clearly the coil's serial number (nameplate);
 - b) Report GE immediately and wait for instructions on how to proceed with the damaged coil;

5 COIL LIFTING

A packaged coil can be lifted by forklift, but the unpacked (OSD/MCD) coil should only be done by crane or overhead cranes.

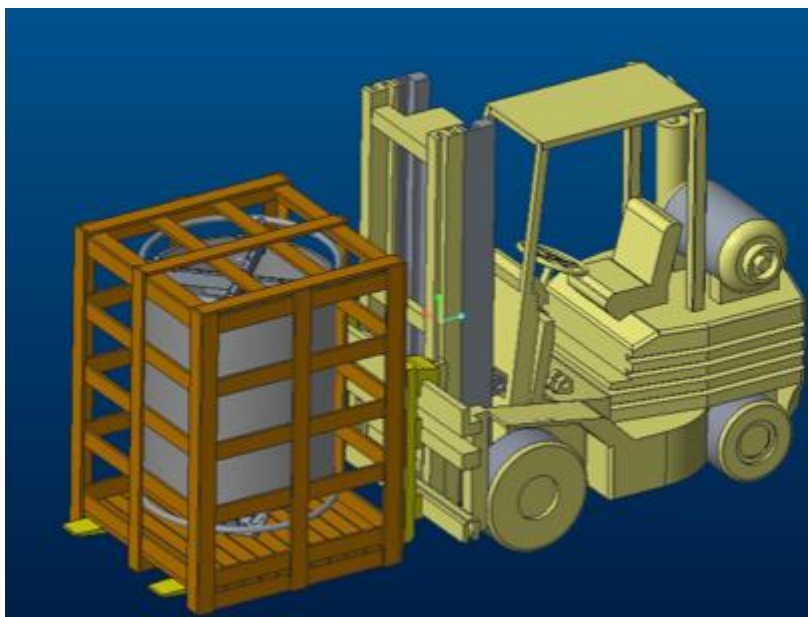



5.1 OSD COIL LIFTING

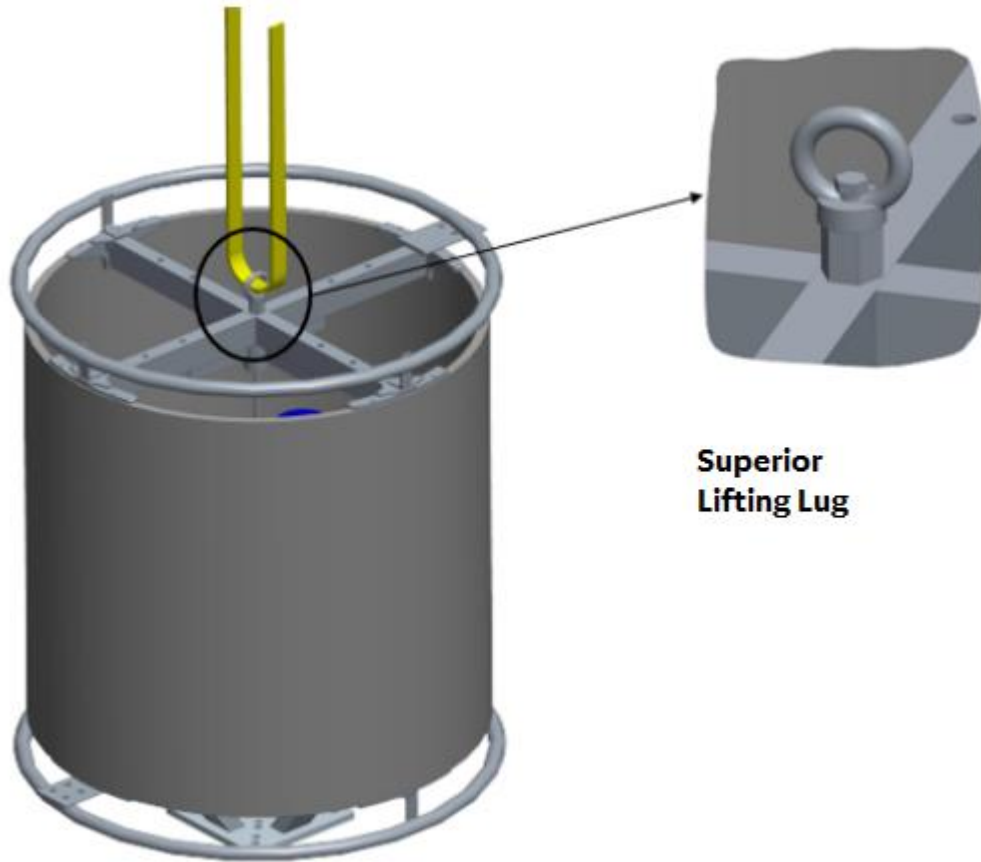

**Superior
Lifting Lug**

5.1.1 MOUNTING: VERTICAL/SUSPENSION MOUNTING (CARRYING: VERTICALLY)

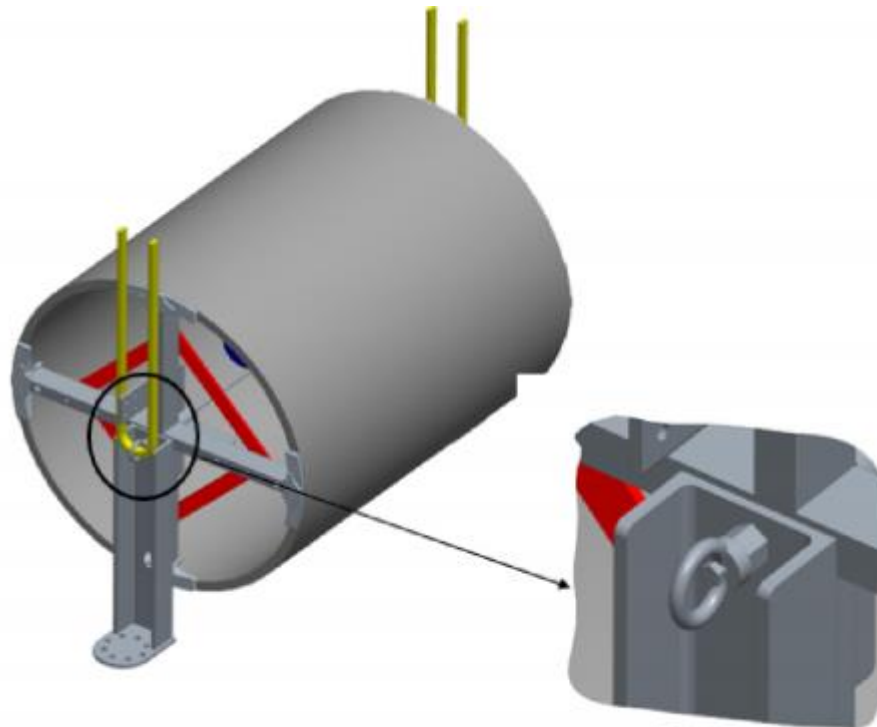

Lateral Lifting Lug



After the line trap's unpacking, lift and handle according to the following procedures:

- Check the equipment weight on the nameplate so that the intended lifting belt shall support the burden.
- Place the line trap pallet in open place for easy handling.
- Pass the lifting belt through the lifting eye on the top cross arm of the equipment, and make sure it is fastened.
- After fitting the equipment to the desired location, make sure that all carrying fittings have been removed.
- Verify that the corona rings, if any, do not rest on the floor, and if the lifting belts used to carry the equipment have missed them causing damage to them.

5.1.2 MOUNTING: HORIZONTAL (CARRYING: HORIZONTALLY)

After the line trap's unpacking, lift and handle according to the following procedures:

- Check the equipment weight on the nameplate so that the intended lifting belt shall support the burden.
- Place the line trap pallet in open place for easy handling.
- Pass the lifting belts through the lifting eyes on the equipment sides, and make sure it is fastened.
- After fitting the equipment to the desired location, make sure that all carrying fittings have been removed.
- Verify that the corona rings, if any, do not rest on the floor, and if the lifting belts used to carry the equipment have missed them causing damage to them.

5.1.3 MOUNTING: VERTICAL/SUSPENSION MOUNTING (CARRYING: HORIZONTALLY)

The lifting procedure of horizontally-carried OSD Line Traps with vertical/suspension mounting on insulators should follow the steps below:

- Unpack the line trap as set out in subsection 4.4.2.
- Check the equipment weight on the nameplate so that the intended lifting belt shall support the burden.
- Place the line trap pallet in open place for easy handling.
- Pass the lifting belt through the lifting eyes on the cross arms of the equipment, and make sure it is fastened. (The figure below depicts lifting of line traps with corona rings, presenting some peculiarities).

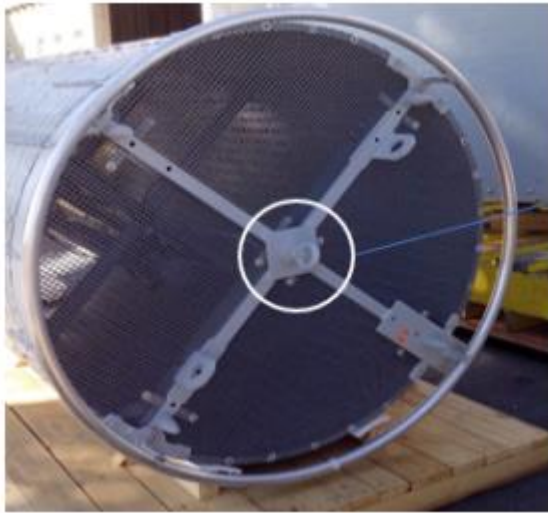

Lifting Lug Detail

Top cross arm lifting belt



Bottom cross arm lifting belt



The top cross arm lifting belt should be positioned on the outside of the corona ring while the bottom cross arm lifting belt should be positioned between the cross arm and the corona ring.





- Lift the line trap slowly until it is in upright position.
- Carry the equipment upright gently to the desired location
- After fitting the equipment to the desired location, make sure that all carrying fittings have been removed.

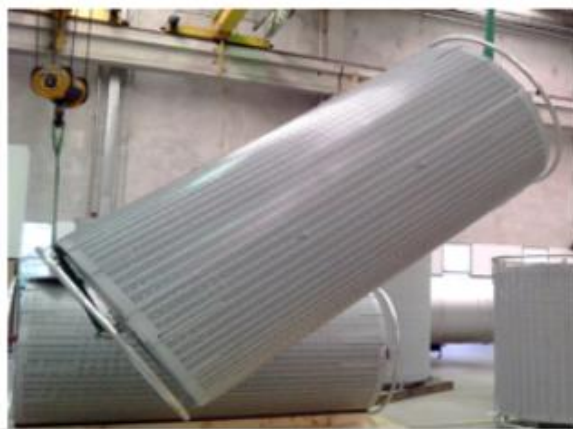

- The bottom lifting belt can be positioned on the line trap's pedestal, if any, so that it does not touch the corona rings during lifting.
- Never lift the line trap through the corona rings, and do not place them on the floor.
- Wooden shims, if any, in the pedestals flanges of line traps must be removed during lifting for placing the coil on the insulators only.





5.2 MCD COIL LIFTING

MCD Line Traps are always packed in the upright position, and lifting is usually managed using the forged steel shackles on the upper cross arm of the equipment. The number of lifting points varies according to each design, but all lifting points must be used as shown in the figure below.

After the line trap's unpacking, lift and handle according to the following procedures:

- Check the equipment weight on the nameplate so that the intended lifting belt shall support the burden.
- Place the line trap pallet in open place for easy handling.
- Pass the lifting belts through all lifting shackles on the top cross arm of the equipment, and make sure it is fastened.
- After fitting the equipment to the desired location, make sure that all carrying fittings have been removed.
- Verify that the corona rings, if any, do not rest on the floor, and if the lifting belts used to carry the equipment have missed them causing damage to them.
- Never attempt to lift the equipment through the corona rings.

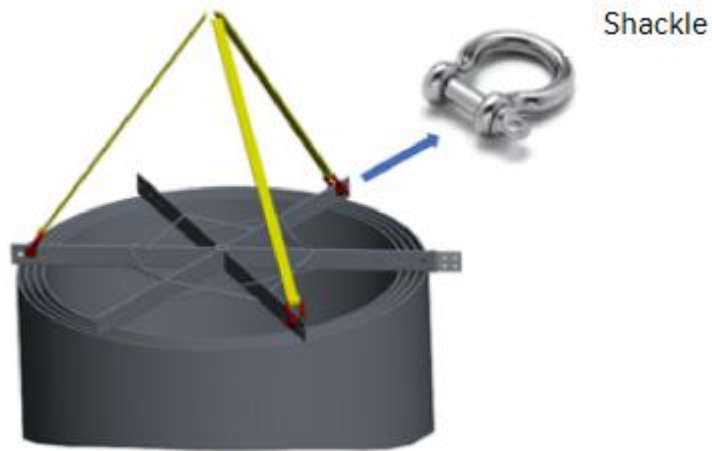

Three point lifting

- In some cases, MCD coils may be lifted by only one fulcrum, or even by the top cross arm spider. Make sure of this information in the dimensional drawing approved by the customer.

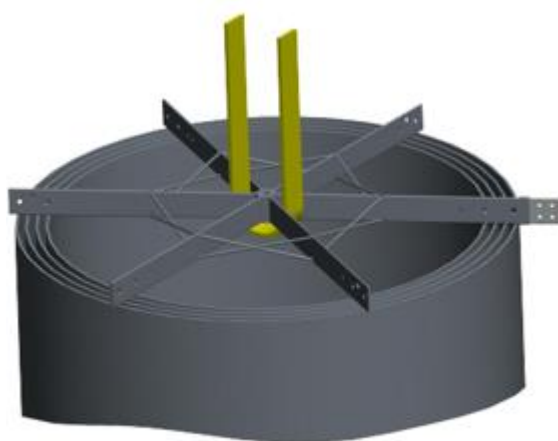

Cross arm core lifting

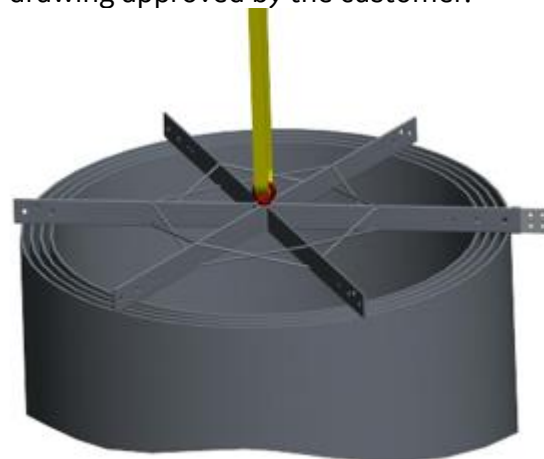

Center lug lifting



6 LINE TRAP MOUNTING

The drawings and manuals provided by GE must be followed carefully by the Line Trap mounting staff.

The line trap lifting device allows easy handling whether for vertical/suspension mounting, located in the center of the top cross arm or horizontal mounting, located in the center of both cross arms.

Permissible tensile stresses are indicated on the main coil nameplate in suspension mounting coils.

Line Traps may be provided with aluminum pedestals for mounting on insulating columns, coupling capacitors or capacitive potential transformers.

NOTES:

-For special (wall, inverted or other) mountings, please ask GE for a technical solution.

- Typically, coil mounting, foundation work, anchoring bolts, or capacitive-column mounting adapters are not provided by GE, but they can be included upon customer's request and stated in the purchase order.

6.1 CONNECTING THE LINE TRAP TO THE TRANSMISSION LINE

The line cable is connected through connectors to flat-bar terminals welded on the cross arms (Refer to subsection 6.2 for details).

When mounted directly on coupling capacitors or capacitive voltage transformers, the line trap connections should follow the wiring diagrams provided in subsection 6.4.

If the line trap mounting is by insulating column or suspension, the line can be connected at any terminal.

In general, the connecting point of the TL input cable to the line trap is the same as the coupling capacitor's (CC) mounting or the capacitive voltage transformer's (CVT) mounting.

The coil pedestal connection to the CVT or CC head shall follow the manufacturer's directions. The CVT/CC manufacturer shall verify the equipment capacity to withstand the line trap weight, wind stresses, line traction, and earthquakes.

6.2 ELECTRICAL CONNECTIONS

The line trap electrical connections should be made as follows:

- 1) Using the appropriate connector (cable, bar, tube), attach the input and output conductors to the coil's line terminals (usually a flat bar located on the equipment cross arms), applying the recommended tightening torque.
- 2) Check if the terminal material is compatible with the line conductor material to avoid aluminum galvanic corrosion (i.e., no contact between copper cables and the aluminum terminals).
- 3) Tinned copper plates or brass connectors may be used for establishing electrical contact with the coil terminals, if necessary.
- 4) For mounting after long storage periods, the contact surfaces should be polished with a fine steel brush or sandpaper together with non-acid lubricating petroleum jelly, which also helps to prevent aluminum corrosion.

**NOTE:**

- Corrosion may increase contact resistance and, consequently, causing overheating at the contact points.

6.3 SCREW TIGHTENING TORQUE

The table below shows the recommended tightening torque for bolts in electrical connections and other connections.

Bolt	Electrical Connection	Insulators and Pedestals	Other connections
	(ft*lbs)	(ft*lbs)	(ft*lbs)
M10	3.0 - 4.0	-	2.0 - 3.0
M12	4.5 - 5.0	4.5 - 5.5	3.0 - 4.0
M16	7.0 - 8.0	12.0 - 14.0	4.0 - 5.0
M20	10.0 - 12.0	16.0 - 18.0	5.0 - 6.0

Bolt	Electrical Connection	Insulators and Pedestals	Other connections
	(ft*lbs)	(ft*lbs)	(ft*lbs)
3/8"	22.0 - 29.5	-	15.0 - 22.0
1/2"	33.0 - 37.0	33.0 - 40.5	22.0 - 29.5
5/8"	52.0 - 59.0	88.5 - 103.0	29.5 - 37.0
3/4"	74.0 - 88.5	118.0 - 133.0	37.0 - 44.0



6.4 - Line Traps connections

6.4.1 - Assembly on CVT

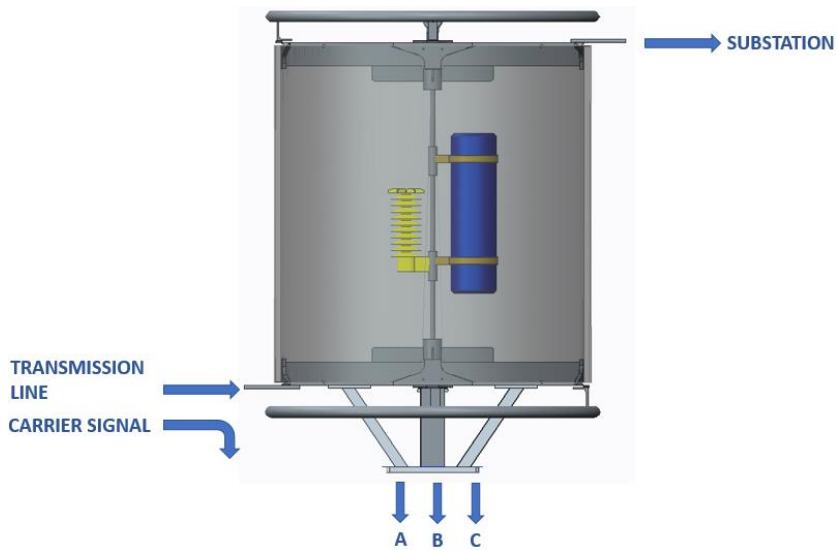

Assembly on CVT

6.4.2 - Assembly on 1 or more post insulators





Assembly on 1 post insulator

Assembly on 2 post insulators

Assembly on 3 post insulators

6.4.3 – Suspended assembly on insulators string



Suspended Assembly



7 COMMISSIONING

This section describes the line trap commissioning procedure before the equipment energization.

- 1) Check the electrical and mechanical connections of line trap components, and screws' tightening as provided in subsection 6.3.
- 2) Check clearance of cylinder spacers in encapsulated MCD coils, and visually inspect clearance of the main coil winding in OSD coils. Unclog with a nonmetallic (fiberglass) rod or air jet, as necessary;
- 3) Check the conductor connections (welding) on the line trap cross arms;
- 4) Check external surface and/or paint. If necessary, retouch painting according to the procedure provided for herein.
- 5) Electrical commissioning tests do not apply to line traps.

8 MAINTENANCE

8.1 GENERAL INFORMATION AND MAINTENANCE PROGRAM

- Maintenance procedures recommended in this manual must be conducted with the line trap de-energized and properly grounded by means of temporary grounding devices.



Typically, locking coils require little maintenance. A maintenance plan depends on the storage conditions (before startup), installation (outdoors or sheltered use), and environment (inclement weather).

At least **one annual inspection** is recommended as standard procedure. However, the interval can be reduced to six months (**two annual inspections**) due to harder conditions as mentioned above.



8.2 PREVENTIVE & PREDICTIVE MAINTENANCE

8.2.1 PROCEDURES

The maintenance procedures are simple, as shown below:

- 1) Visual inspection of the line trap and framework:
 - a. Check the conductor connections (welding) on the line trap cross arms;
 - b. Check external surface and/or paint;
 - c. Check good condition of fiberglass ties between the top and bottom cross arms, and ties between the shims and winding of the main coil.
- 2) In polluted or aggressive environments, the coil winding and framework can be cleaned by flushing a pressurized water jet at 3m distance minimum.
- 3) Check the electrical and mechanical connections of the line trap components, and tightening of screws as provided in subsection 6.3, for the parts listed below.
 - a. Line terminals
 - b. Insulators or TVC or CC.
 - c. Pedestals and shoes.
 - d. Line terminal connectors.
- 4) If paint retouching is required, refer to the procedures in subsection 8.3.
- 5) If field measuring equipment is available, coil inductance measurements at 100 Hz or 100 kHz and tuning device component measurements at 1 kHz are recommended. These measurements might be compared to the factory test reports.



8.3 PAINT

In case of field repair, it is essential that all paints used in line trap finish are approved by GE.



The GE factory paint process is described below:

- 1) Cleaning by air blasting in winding and cooling ducts;
- 2) Glass bead blasting for better grip;
- 3) Aliphatic polyurethane finish, with standard 75-125 μm dry paint thickness, in the color stated in the dimensional drawing. Curing time of paint is at least four days at 20°C ambient temperature, 80% relative humidity.
- 4) The total dry paint film thickness is at least 75 μm .

NOTES:

- Besides the standard ANSI 70 color used in GE Brazil line traps, other colors like RAL or Munsell standard are available as well.
- Special paints or nonstandard colors must be clearly specified in the offer/purchase order.

8.3.1 PAINT RESTORING

If paint restoring is necessary, follow the procedure below:

- 1) Encircle the line trap's damaged area with adhesive tape;
- 2) Remove paint from the encircled area using fine sandpaper;
- 3) Clean the area with solvent or alcohol;
- 4) Dry the area;
- 5) Using a brush or air gun, apply one coat of paint finish as specified in subsection 8.3;
- 6) Cover the painted surface with plastic (or similar) to protect it from the sun or rain for 24 hours, for good drying of the paint;

NOTE: Please note that drying times above consider 20°C ambient temperature and materials used by GE. For brand paints, refer to the manufacturer's directions.



9 ENVIRONMENTAL EFFECTS

MCD/OSD line traps are built with materials considered environmentally friendly. For product disposal, follow the processing below to minimize environmental effects:

Component	Material	Recommended Destination
Cross arms	Aluminum or copper	Recycling
Winding encapsulation	Epoxy impregnated fiberglass	Co-processing, or licensed industrial landfill
Conductors	Aluminum or copper	Recycling
Insulators	Porcelain or polymer	Co-processing, or licensed industrial landfill
Pedestals	Aluminum or galvanized steel	Recycling
Spacers, bird barriers and fittings	Fiberglass and epoxy	Co-processing, or licensed industrial landfill
Fiberglass ring	Fiberglass and epoxy	Co-processing, or licensed industrial landfill
Package	Wood	It can be reused or burned for energy, except preservation wood that must be recycled according to local regulations.
Package	Plastic film (PE)	It can be recycled or burned for energy
Tuning Device (Capacitors, Inductors, Resistors, Fiberglass Tubes, Plastic and Epoxy Holders)	Fiberglass, plastic, epoxy	Co-processing, or licensed industrial landfill
Protective Devices (Lightning arrester, and clamps)	Fiberglass, plastic, epoxy, metal	Co-processing, or licensed industrial landfill



10 APPENDICES

10.1 REMOVING/INSTALLING BIRD BARRIERS

Bird barrier removal should follow the procedure below:

- Evaluate which of the quadrants to remove from the line trap.
- With the appropriate tool, remove all of the aluminum bracket screws and all fiberglass discs.
- Remove the desired quadrant.
- Sometimes, the bottom bird barrier has opaque fiberglass quadrants, but the removal procedure is the same as mentioned above.

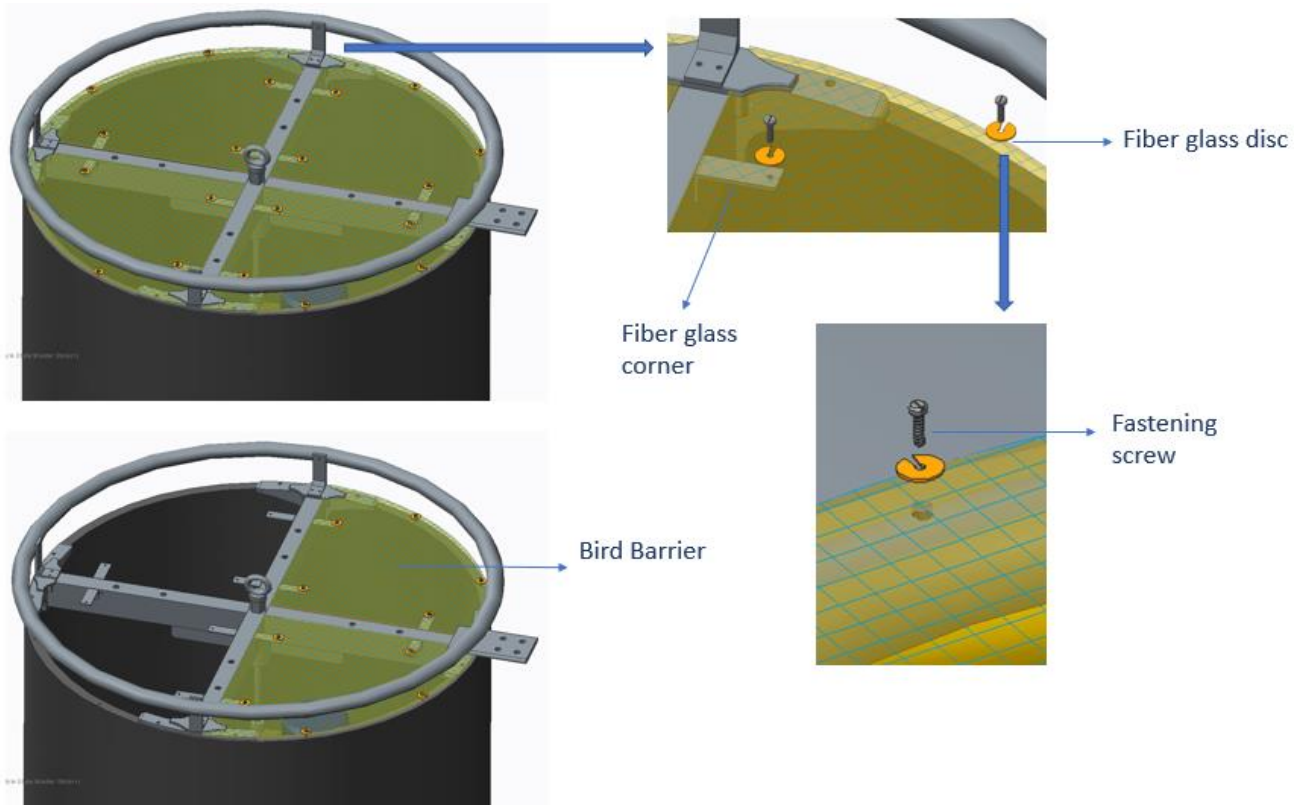

- The bird barrier installation is simply the reverse process to removing them. It is important that the fiberglass discs are placed between the angle brackets and the fixing screw.
- In some line traps, bird barriers are fastened without screws, fiberglass discs or aluminum brackets. Fastening in this case is done by UV (ultraviolet) protected clamps as shown in the figure below.

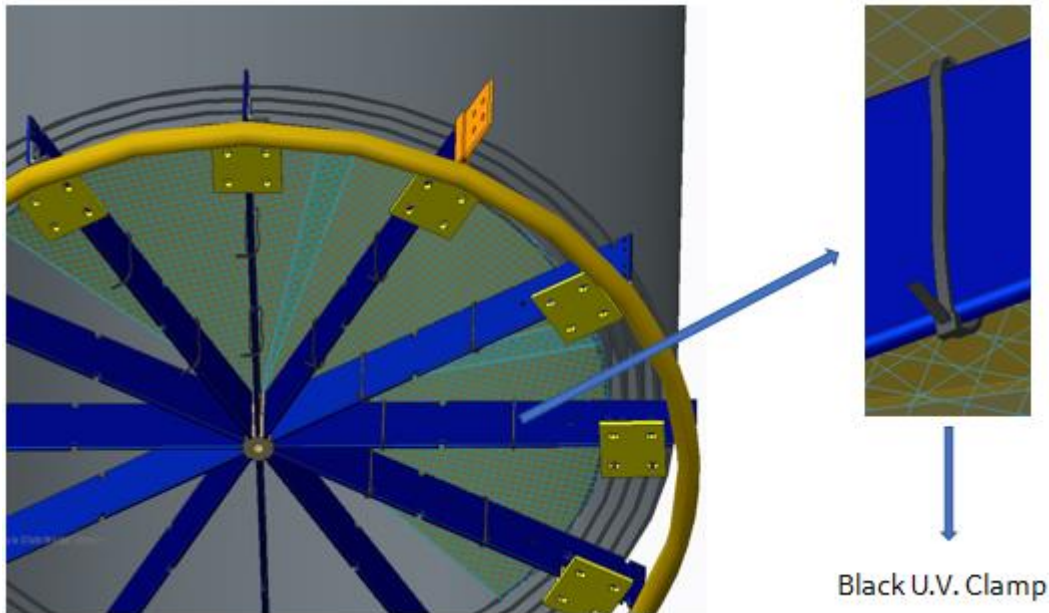

(Black UV-protected clamp)

Removing a bird barrier quadrant is accomplished with an appropriate cutting tool, and its installation is just attaching new UV-protected clamps, included as spare parts in the line trap package.

10.2 REMOVING/INSTALLING THE TUNING DEVICE

To reach the line trap tuning device, the bird barriers have to be removed as set out in Appendix 10.1.

- The tuning device must remain short-circuited during handling, because it may be charged at high voltage due to the magnetic field of the main coil. This charge may remain on the device for a considerable time.



REMOVAL of the tuning device is necessary for maintenance, reset or tuning by customer. In this case, proceed as follows:

- With the appropriate tool, remove the top and bottom cross arm connecting cables, which refer to the line traps' tuning device and lightning arrester.
- Then remove the cables from the tuning device rods.

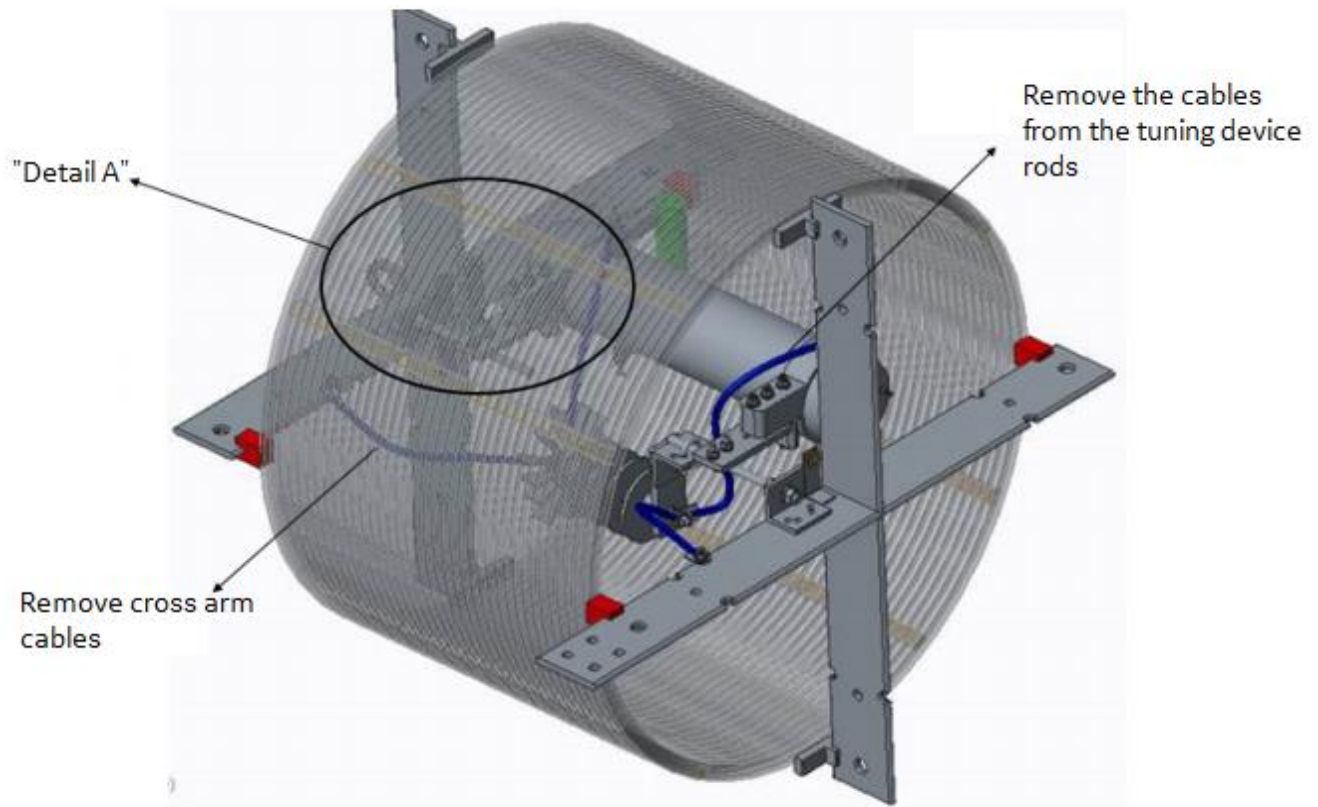

- Unscrew the U-clip bolts that attach the tuning device at both ends of the coil's central rod, and take the tuning device out. (Detail A)
- The tuning device is taken out with both fastening clamps, because these parts are provided in the new device.
- If removing the tuning device from the fastening clamps is required, unscrew the fastening screws. (Detail A)



"Detail A"

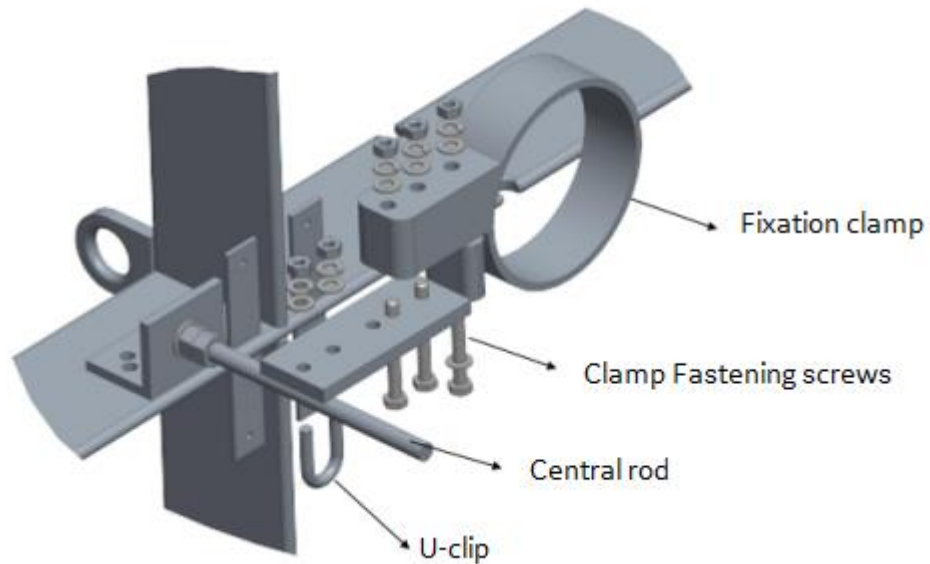

- Removal of the tuning device with outer diameter 546-mm has some peculiarities. Before starting the procedure above, remove the tuning device's external resistor. Due to the limited space for removing the tuning device, remove its fastening clamps if necessary.

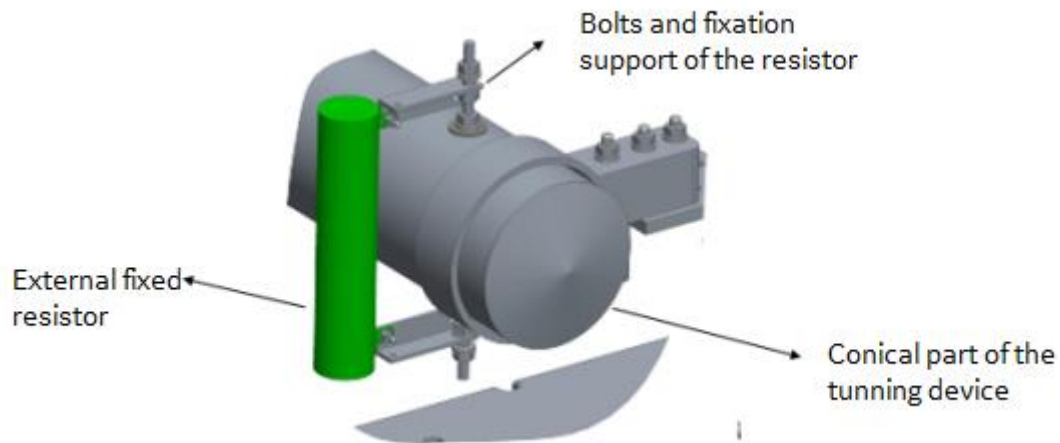

Line traps with outer diameter 546-mm have a heat shield, attached parallel to the tuning device, which must be removed with the resistor.



INSTALLATION of the tuning device must follow the procedure below:

- Verify the nameplate of the new tuning device for the correct tuning and insulation data.
- Insert the tuning device with the clamps into the main coil.
- The **conical part** of the tuning device should be oriented toward the top cross arm of the coil.
- After positioning the tuning device inside the coil, screw the U-clips to the central rod.
- Connect the tuning device and arrester cables to the top and bottom cross arms of the coil. When tightening the connectors on the tuning device terminals, grab the first nut with a suitable wrench. **(No rotating action should be applied to the rod).**
- If the tuning device's fastening clamps are removed, then replace them and tighten the nuts to a torque up to 0.5 daNm.
- For line traps with outer diameter 546-mm, attach the heat shield and the external resistor once the tuning device is inserted and fastened. The torque here is 0.5 daNm.
- Once the tuning device is installed, attach the bird barriers as set out subsection 10.1.



TECHNICAL ASSISTANCE

GE POWER - AIB

Avenida Nossa Senhora da Piedade, 1021 - Bairro Piedade
Itajubá - Minas Gerais - Brazil
CEP 37504-358

 +55 35 3629-7000

 +55 35 3629-7007

+After sales numbers:

 LATAM: +55 11 2813-6999

 Brazil: 0800-546-7389