



INSTRUCTIONS

GEI-71676E
INSERT BOOKLET GEK-1253

FAULT DETECTOR RELAY

TYPES
CHC12A
CHC13A
CHC13B

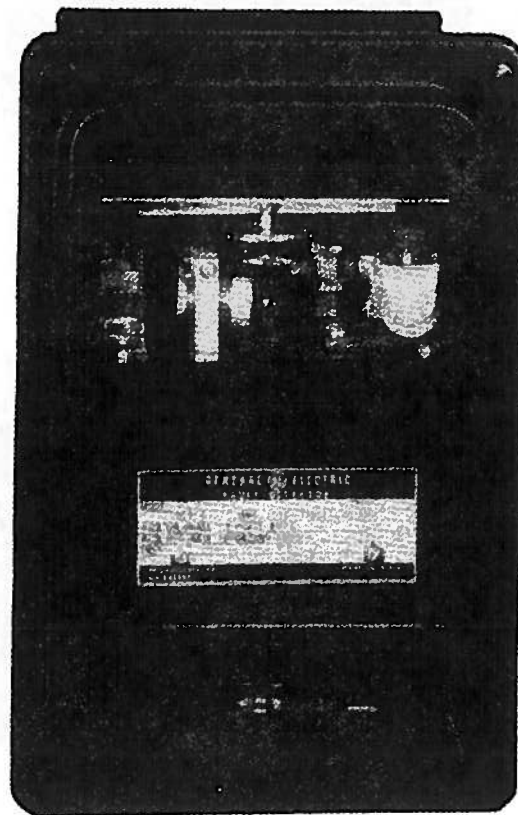

GENERAL  **ELECTRIC**

GEI-74676 Fault Detector Relay Type CHC

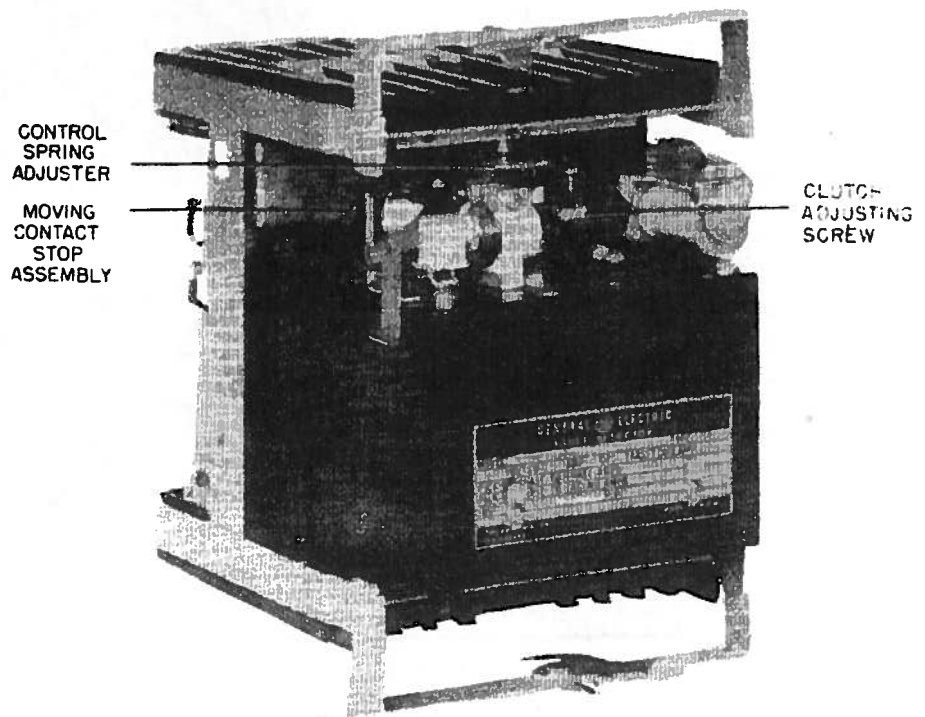
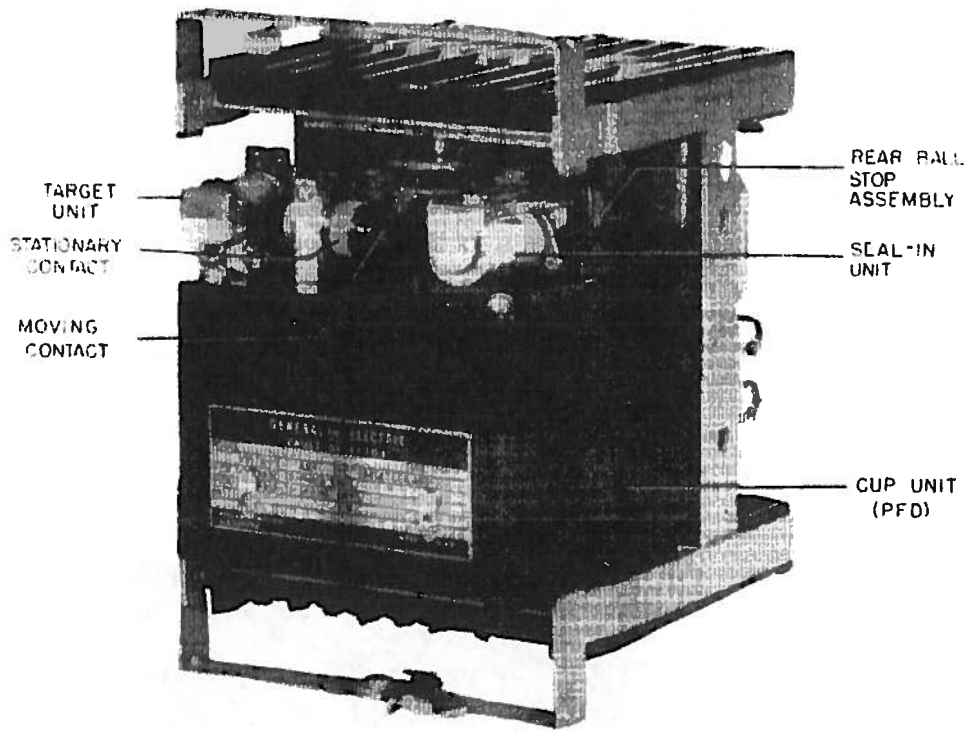

Fig. 1 (8030330 & 8030329) CHC12A Removed From Case

Cover (8030319)

FAULT DETECTOR RELAY

CHC12A, CHC13A AND CHC13B

INTRODUCTION

This supplement in conjunction with GEK-1253 forms instructions for the CHC12A relay. All information pertinent to the CHC12A relay but not covered by this supplement is as shown in GEK-1253.

The CHC12A relay is a three-phase high speed nondirectional overcurrent relay. The relay consists of an induction cup unit (PFD), a target unit, and a telephone-type seal-in unit mounted in an S-2 size drawout case.

The CHC13A is similar to the CHC12A except for the contact circuit arrangement. The CHC13A (PFD) operates an auxiliary telephone relay which provides two normally open electrically separate contacts. A target is wired in one of these contact circuits. This auxiliary relay occupies the same position as the seal-in unit in the CHC12A. The auxiliary relay is a D.C. continuously rated unit that draws less than 5 watts.

The CHC13B is similar to the CHC13A except for internal connection.

The main operating unit of this relay is similar in construction except for the moving element stop screw, and has the same operating characteristics, as the PFD unit of the CHC11A relay described in the attached GEH-2035.

APPLICATION

The CHC12 relay is designed for use as a current fault detector in connection with distance relays, to prevent operation of the associated timer, or tripping of the circuit breaker due to loss of relay potential supply for other reasons than a system fault. This can occur due to (1) short circuits or open circuits involving the potential supply, or (2) due to switching (with some configurations of power circuits), or (3) due to the use of line-side potential supply. In the latter case, the fault detector protects the timer against burnout, and prevents false re-tripping of the circuit breaker at the instant of reclosure.

The case size and internal connections are arranged to provide mechanical and electrical interchangeability with the PJC31C or D. The advantage of the CHC over the PJC is that it is designed to permit operation in the picked up position, so that it can be used where the maximum load current

exceeds the minimum fault current. During load conditions which pick up the CHC, it cannot perform function (1) above, and it may or may not perform function (2) above (depending on whether the connections are such as to pick up the CHC), but it will always perform function (3).

The relay includes a separate target and seal-in unit operated from trip current.

The target and seal-in units ratings are given below:

Rated Current	Operating Range	Trip Duty AMPS	Resistance OHMS
0.2	0.2 - 3	3	12.4
1.0	1 - 30	30	0.64
2.0	2 - 30	30	0.22

Typical external connections for both CHC12A and CHC13A are shown in Figs. 2 and 7 of this supplement.

CONSTRUCTION

Outline and Panel Drilling dimensions for the Type CHC12A, CHC13A and 13B relays are shown in Fig. 8 of this supplement.

The internal connections for these relays are shown in Figs. 3, 4 and 5 of this supplement.

RECALIBRATION

The moving contact stop screw assembly of this relay is on the left rear section of the moulded head directly behind the stationary contact.

The contact gap of the PFD is 0.020 inch. This gap is set at the factory and it normally will not be necessary to reset it. However, if an inspection indicates that this setting has been disturbed the following procedure is recommended.

- Remove the rear ball stop assembly.
- Loosen the locking screw of the contact stop screw assembly and advance the stop screw until the moving contact arm is parallel to the sides of the cup unit.

These instructions do not purport to cover all details or variations in equipment nor to provide for every possible contingency to be met in connection with installation, operation or maintenance. Should further information be desired or should particular problems arise which are not covered sufficiently for the purchaser's purposes, the matter should be referred to the General Electric Company.

To the extent required the products described herein meet applicable ANSI, IEEE and NEMA standards; but no such assurance is given with respect to local codes and ordinances because they vary greatly.

GEI-74676 Fault Detector Relay Type CHC

- c. Advance the stationary contact assembly until it just touches the moving contact. A neon lamp connected across terminals 1 and 12 is best suited for this purpose.
- d. Tighten the clamping screw so that the stationary contact is secure.
- e. Back off the stop screw until the measured gap is 0.020 inch between the stationary and moving contacts. (It should be noted that 0.020 inch corresponds to approximately two-thirds of a turn on the stop screw).
- f. Tighten the locking screw of the moving contact assembly stop screw in this position. Care should be taken so as not to disturb the contact adjustment and it should be noted that the locking screw bears on the moving contact stop assembly support.

With the connections of Fig. 6 of this supplement, set the current of the cup unit at the minimum pickup value and adjust the control spring as described under **SETTINGS**, in the attached *GEK-1253 to obtain pickup. Replace the rear ball stop assembly and advance it slightly, making sure that the moving contact arm does not touch the rear ball stop assembly when it is pushed by hand to close and wipe in on the stationary contact. Now, change the current to 1.5 times the minimum pickup current. By means of switch S (Fig. 6), apply current suddenly and observe whether the cup unit contacts bounce open. A neon light connected across terminals 1 and 12 is best suited for this purpose. If there is no visible contact bounce, tighten the clamping screw to hold the ball stop assembly in position. If the contacts bounce, advance the rear ball stop

assembly carefully until there is no contact bounce when current is suddenly applied. Be sure not to advance the assembly excessively, as it will change the cup unit pickup. (The moving contact arm should touch the rear ball stop assembly after the front contact closes and wipes in at least 0.005 inch). To make sure the rear ball stop assembly is not advanced excessively, reduce the current through the relay to the minimum pick up value. The relay should operate to close its contacts at that value.

The pickup of the cup unit may be changed in the manner described under **SETTINGS** of PFD in attached GEK-1253.

With the connections of Fig. 6, the clutch should be adjusted to slip at approximately 20 amperes. The clutch slipping point may be changed by turning the clutch adjusting screw. Turning the screw clockwise will cause the clutch to slip at a higher value of current. Be sure to tighten the locking nut, but be careful not to disturb the clutch.

SEAL-IN UNIT AND TARGET UNIT

1. Mechanical Adjustments Seal-In Unit

- a. There should be at least 1/32 inch clearance between the armature and the pole piece.
- b. The normally open contacts should have a gap of 0.015 inch and the normally closed contacts should have at least 15 grams pressure as measured at the contact tip. The normally open contacts should close with at least 0.005 inch wipe. The normally closed contacts should open to a gap of 0.015 inch.

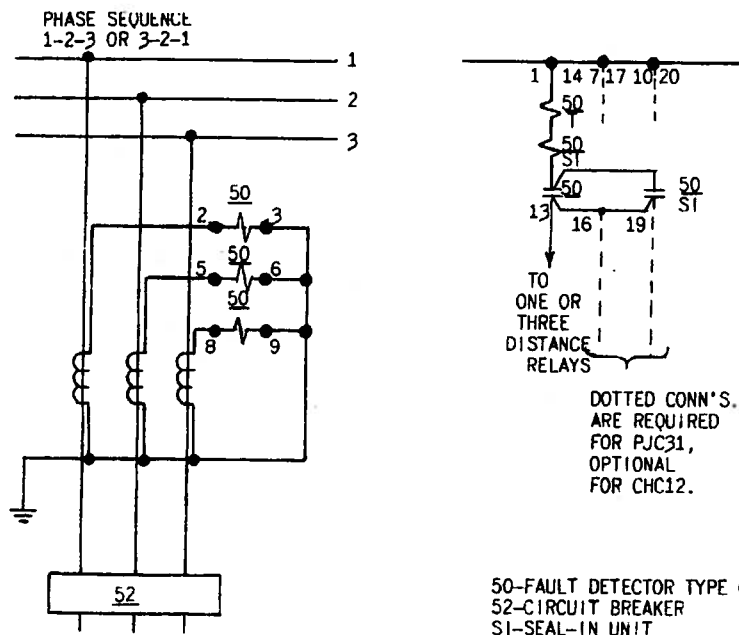
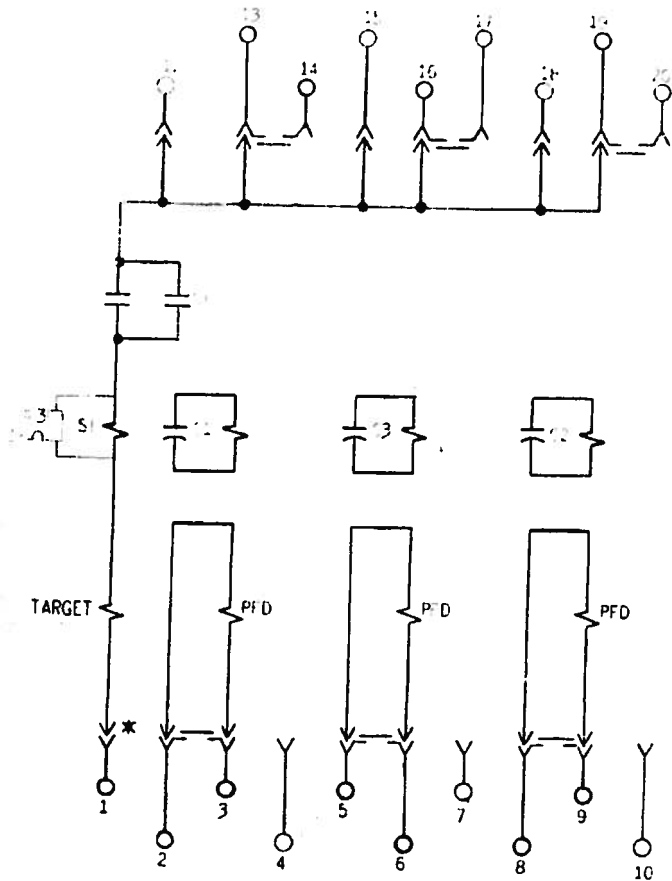

Fig. 2 (0165A6007-0) Typical External Connections For The CHC12A Relay



* = SHORT FINGER

Fig. 3 (0148A3956-6) Internal Connections (Front View) For The CHC12A Relay

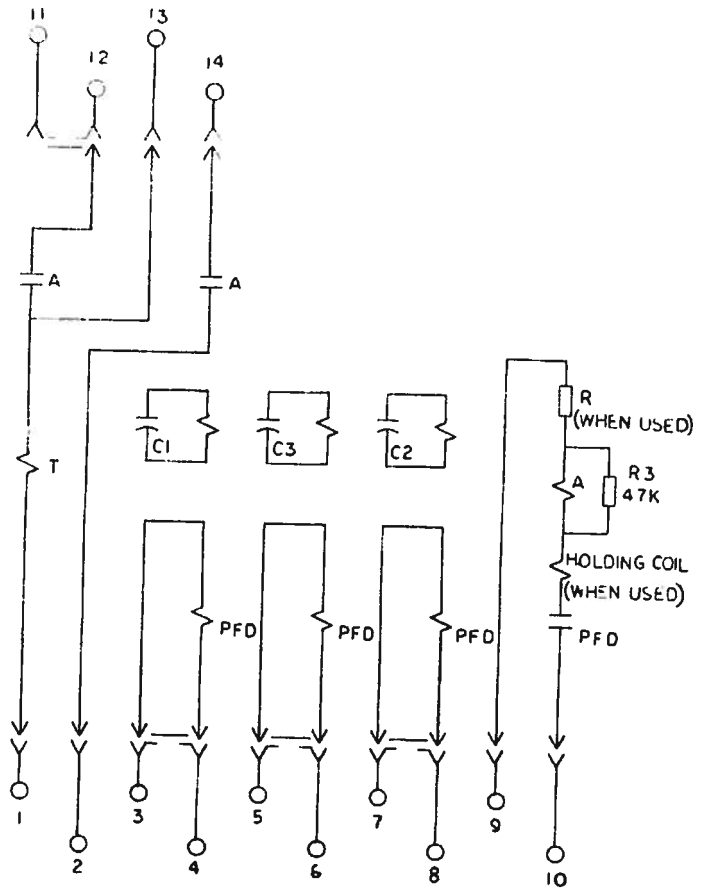

Fig. 4 (0165A7519-67) Internal Connections For Type CHC13A Relay (Front View)

GEI-74676 Fault Detector Relay Type CHC

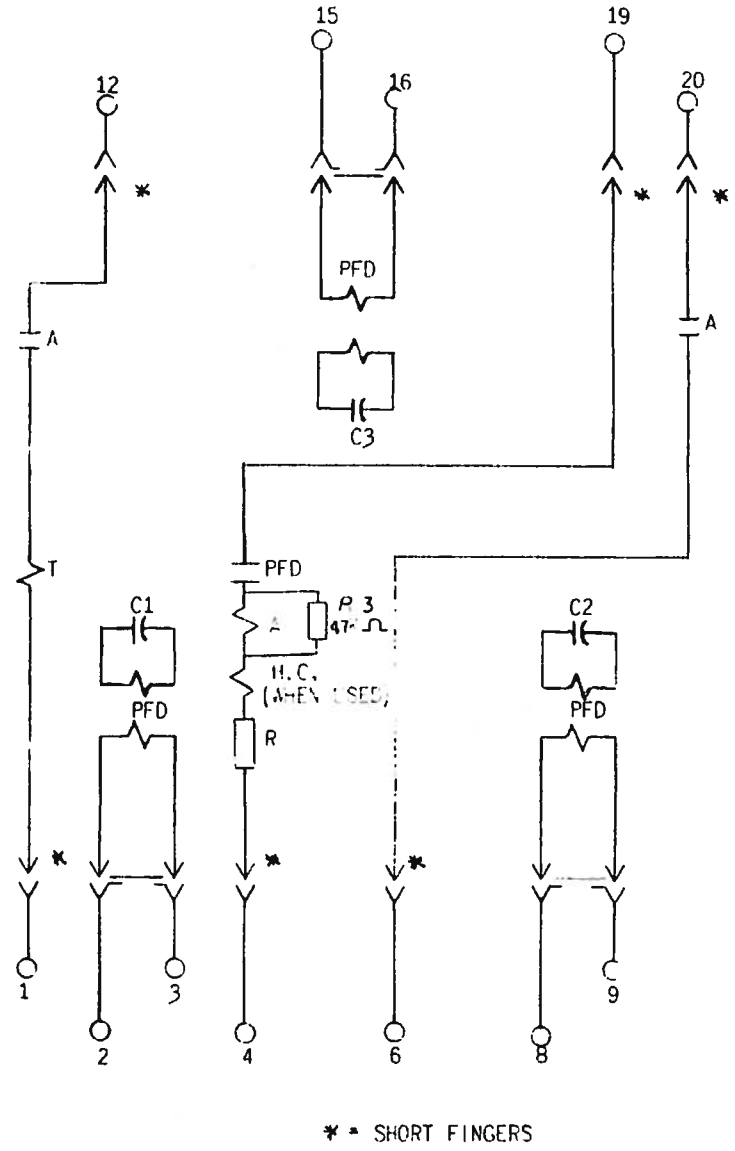

Fig. 5 (0178A7139-5) Internal Connections For Type CHC13B Relay (Front View)

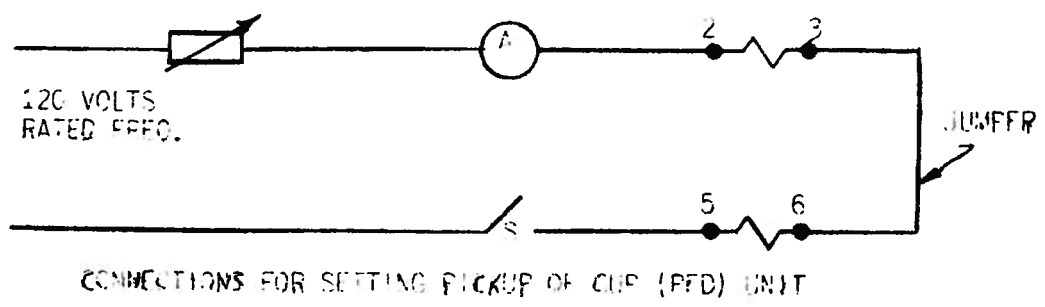
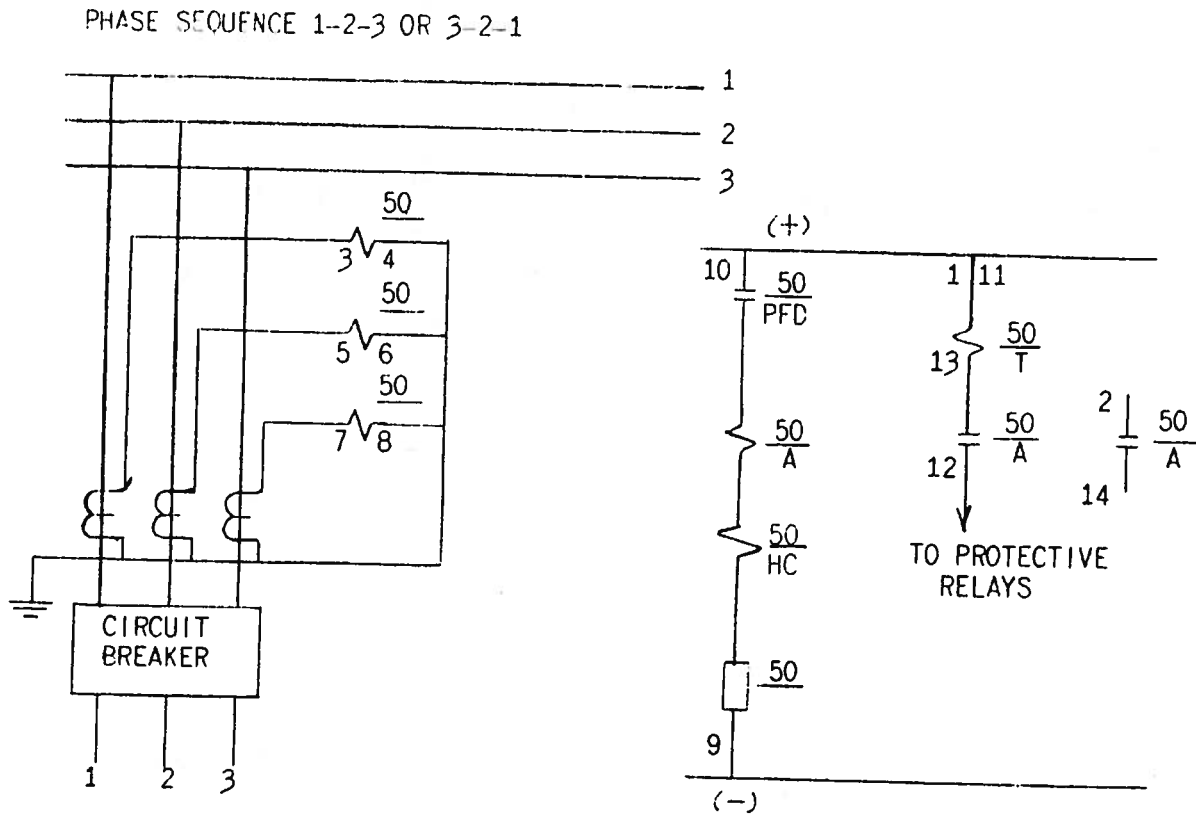

Fig. 6 (0165A6011-) Test Connections For The PFD Unit Of The CHC12A Relay



NOTE: A SHORTING BAR EXISTS BETWEEN STUDS 11 & 12 SO THAT WHEN RELAYS REMOVED FROM CASE POSITIVE POTENTIAL IS BROUGHT DIRECTLY TO THE PROTECTIVE RELAYS. IF THIS IS NOT DESIRED, MAKE NO CONNECTION TO STUD .11.

LEGEND

- 50 - CHC13A
- PFD - PHASE FAULT DETECTOR
- A - AUXILIARY UNIT
- T - TARGET
- H.C. - HOLDING COIL (WHEN USED)

Fig. 7 (0178A7089-1) External Connections For The CHC13A Relay

GEI-74676 Fault Detector Relay Type CHC

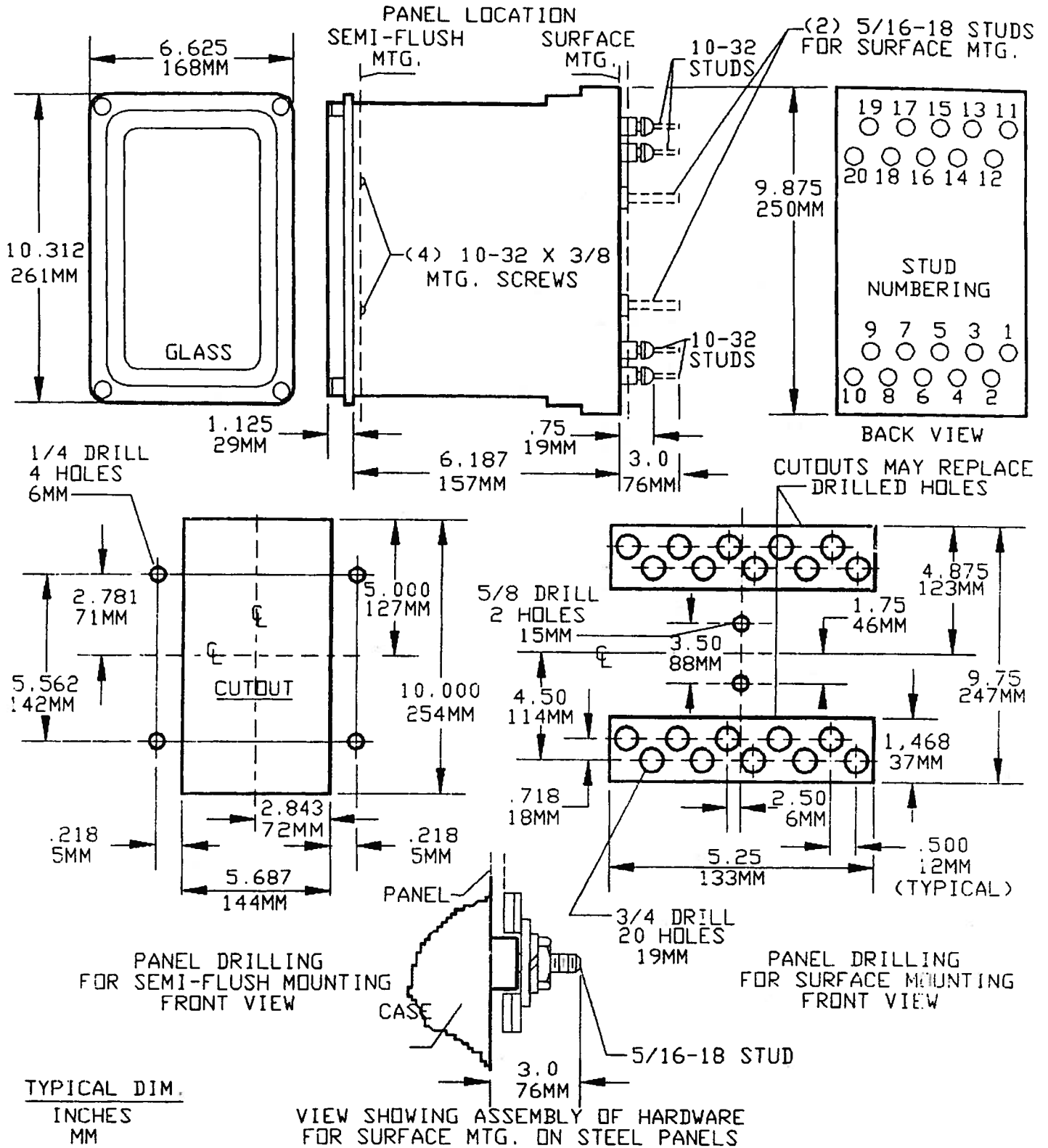

TYPICAL DIM.
 INCHES
 MM

* Fig. 8 (6209272 [7]) Outline and Panel Drilling Diagram for the CHC12A, CHC13A and CHC13B Relays

*Indicates revision.