

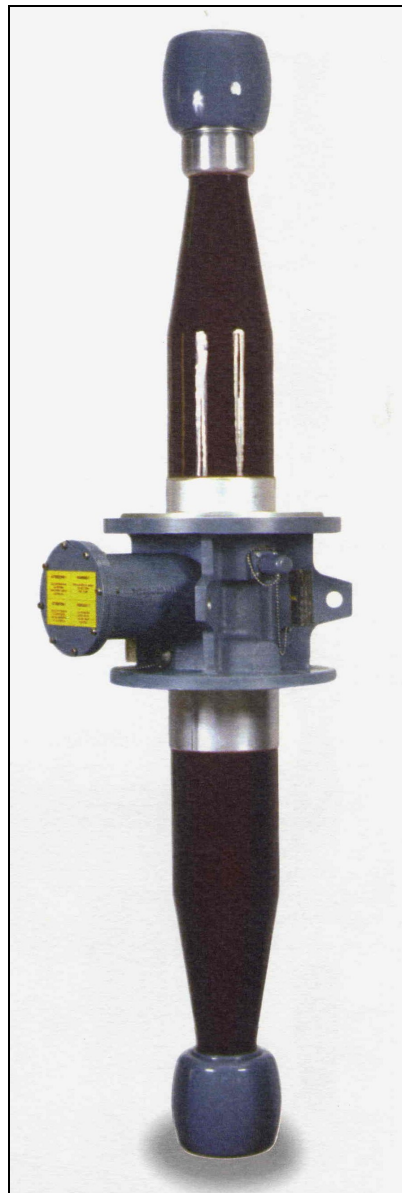

Via Mario Villa,210
20099 Sesto San Giovanni (MI), Italy
Tel. +39 02 24 10 50 01
www.ge.com

IS 2541 GB
Page 1 of 13

**OIL TO SF6 BUSHINGS SERIES POBO
OIL TO OIL BUSHINGS SERIES PCTO
VOLTAGE FROM 72,5 TO 765 kV**



**STORAGE, OPERATING
AND MAINTENANCE INSTRUCTIONS**



**OIL TO SF6 AND OIL TO OIL BUSHINGS
SERIES POBO/PCTO
VOLTAGE FROM 72,5 TO 765 kV**

IS 2541 GB

Page 2 of 13

Instruction Manual

Rev. G – August 2019

INDEX

1. DESCRIPTION 3

1.1 GENERAL3

1.2 SAFETY3

1.3 TECHNICAL CHARACTERISTICS.....3

1.4 TYPE OF DIELECTRIC4

1.5 NAME PLATE.....4

2. MOUNTING INSTRUCTIONS..... 4

2.1 ACCEPTANCE.....4

2.2 STORAGE.....5

2.3 LIFTING AND TRANSPORTATION.....5

2.4 SHIPMENT TO THE END USER5

2.5 INSTALLATION ON THE TRANSFORMER.....5

2.6 TEMPERATURE LIMITS6

2.7 OIL FILLING OF TRANSFORMER6

2.8 CONNECTION TO BUCHOLZ RELAY.....7

2.9 INSTALLATION AND CONNECTION TO THE SF6/CABLE SIDE.....7

3. SERVICE AND MAINTENANCE..... 7

3.1 METAL PARTS.....7

3.2 CHECKS AFTER INSTALLATION7

3.3 MAINTENANCE7

3.4 PRESSURE GAUGE - ALARM DEVICE8

4. DISASSEMBLY OF THE BUSHING..... 9

5. MEASUREMENT OF DIELECTRIC LOSSES..... 9

6. CHECKS ON OLD BUSHINGS 9

7. EXTRAORDINARY CHECKS 9

8. OIL SAMPLING..... 11

8.1 EQUIPMENT11

8.2 OIL SAMPLING12

9. DISPOSAL AT THE END OF LIFETIME 13

Revision G	August 2019
Revision F	August 2017
Revision E	April 2015
Revision D	February 2009
First edition	March 1973



**OIL TO SF6 AND OIL TO OIL BUSHINGS
SERIES POBO/PCTO
VOLTAGE FROM 72,5 TO 765 kV**

IS 2541 GB

Page 3 of 13

Instruction Manual

Rev. G – August 2019

1. DESCRIPTION

1.1 GENERAL

These instructions are applicable to the OIP (oil-paper) condenser bushings of series:

“POBO” – “PCTO” Rated voltage 72,5 to 765 kV

according to IEC 60137 - 1995 Standard and give all general information to be followed from the receipt of bushings until their installation on the transformer. Other information is given regarding their service and maintenance.

These bushings are manufactured and tested in compliance with Standard IEC 60137 “Insulated bushings for alternating voltages above 1000 V”.

Design, components and manufacturing technology guarantee an average lifetime longer than 30 years, in normal operation conditions.

The designation of the bushing is made as in the following example:

POBO.245.1050.1000

P Condenser bushing (“P” from Italian word “Passante”)

{ OB Normal tail type, oil to SF6
{ CT Cable to transformer type

O Oil paper insulation (OIP)

245 Rated voltage (in kV)

1050 BIL – Basic Insulation Level (in kV)

1000 Rated current (in A)

1.2 SAFETY

This manual must be available to the personnel responsible of the installation, operation and maintenance of the bushings.

The installation, operation and maintenance of the bushings, present conditions of no safety and it is necessary to follow carefully specific procedures and instructions. No compliance with these procedures and instructions can involve very severe and dangerous conditions for the personnel and the property.

1.3 TECHNICAL CHARACTERISTICS

These bushings are capacitance-graded type, oil impregnated type (OIP), designed for operation one side immersed in the transformer oil, the other one in SF6 gas for GIS application (POBO series), or cable oil (PCTO series) - fig. 1.

The body of the bushing is a continuous sheet of pure Kraft paper, wound around a conductor rod and oil impregnated, with aluminium foils inserted within the paper layers; this condenser execution improves radial and longitudinal distribution of electric gradients. It is manufactured with conic envelopes of porcelain on both sides and a central metallic body having a double flange. Versions with under flange sleeve in transformer oil side for CT accommodation are available upon request.

The schematic design is shown in figure 1.

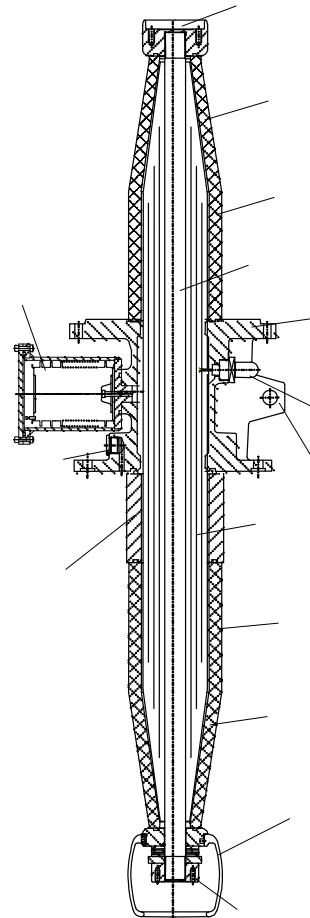

Fig. 1

Both sides housings are made of brown porcelain (grey upon request).

Mechanical coupling among all the components is obtained by compression springs placed at one side of the bushing.

All the gaskets are O-ring type, in fluorinated elastomer.

Flat gaskets are also provided in order to prevent the contact between porcelain and metal parts.

The bushings of this series can be mounted in every position.

Both sides are shielded by suitable electrodes, made of aluminium alloy casting or aluminium sheet for the

	OIL TO SF6 AND OIL TO OIL BUSHINGS SERIES POBO/PCTO VOLTAGE FROM 72,5 TO 765 kV	IS 2541 GB
Page 4 of 13	Instruction Manual	Rev. G – August 2019

bigger ones. It has the function of reducing the electric gradient in oil by screening the connections

The flange is equipped with the following accessories:

- Power factor tap;
- Safety manometer with contacts for minimum and maximum pressure;
- Buchholz relay connection;
- Lifting holes.

1.4 TYPE OF DIELECTRIC

The impregnation is made with a top quality inhibited super grade mineral oil, fully complying to Standards IEC 60296 and ASTM D3487, with the following outstanding characteristics:

- High dielectric strength (>70 kV/2,5mm);
- Very good low temperature properties (pour point typically <-60 °C);
- Low viscosity even at the lowest temperatures;
- Very good oxidation stability;
- Extremely good heat transfer.

1.5 NAME PLATE

Each bushing is provided of a name plate, with serial number and all the electrical data, in accordance with the prescription of IEC Standards.

The plate (fig. 2) is made of aluminium and is fixed on the flange by nails. On the plate the following information are indicated:

Name plate detail

PASSONK VILLA MILAN ITALY		SERIAL NR. <input type="text"/>	M./YEAR <input type="text"/>
PASSANTE-BUSHING-TRAVERSEE-DURCHFUEHRUNG			
TYPE <input type="text"/>			
⊙	STD REF. <input type="text"/>	50-60Hz	⊙
Um <input type="text"/> kV	BIL/SIL/AC <input type="text"/>	kV	Ir <input type="text"/> A
C1 <input type="text"/> pF	C2 <input type="text"/> pF	P.F. <input type="text"/> %	AT 10kV/20°C
<input type="text"/> °	<input type="text"/> kg	<input type="text"/>	

Fig. 2

The month is indicated by a code, as follows:

- | | | |
|--------------|------------|---------------|
| A = January | E = May | P = September |
| B = February | H = June | R = October |
| C = March | L = July | S = November |
| D = April | M = August | T = December |

2. MOUNTING INSTRUCTIONS

2.1 ACCEPTANCE

Upon receipt of the goods the Customer should operate as follows:

- Check the external surfaces of the packing cases:
 - No sign of damage shall be found;
 - The shock indicator, placed in the external part of each packing case (fig. 3), must be white.



Fig. 3

If the shock indicator is red don't refuse shipment, make a notation on delivery receipt and inspect for damage as follow:

- Open the packing case by removing its cover;
- Make sure that the anchoring elements are in order and securely fixed;
- Make sure that there are no leaks from the bushings, especially in the joints between porcelain and metal parts and that there are no breaks or broken parts. Please consider that each bushing has been tested with the tail immersed in oil, therefore some oil traces can be found.

In case any damage is found, leave the original packaging and request an immediate inspection from carrier within 15 days of delivery. Moreover, give the forwarding agent a written claim and notify the manufacturer with the details of the packing list, including the number of the case and the serial number of the bushing, to the following address:

GRID SOLUTIONS SpA - Unit RPV
Via Mario Villa, 210
20099- Sesto San Giovanni (ITALY)
PHONE: +39-02-24105001



**OIL TO SF6 AND OIL TO OIL BUSHINGS
SERIES POBO/PCTO
VOLTAGE FROM 72,5 TO 765 kV**

IS 2541 GB

Page 5 of 13

Instruction Manual

Rev. G – August 2019

2.2 STORAGE

Although there is no preclusion for the bushings remaining in the open air, it is preferable to store them in a closed location.

The temperature range acceptable for the storage is from -25 to +50 °C.

For special requirements regarding low ambient temperatures (see paragraph 2.6), where special O-rings are foreseen, the bushings can be stored at temperature up to -55°C.

When the bushing is taken out from the storage it is necessary to make a visual check to be sure about the good conditions of any part.

2.3 LIFTING AND TRANSPORTATION

The bushings type POBO and PCTO are sturdy, nevertheless, in order to avoid dangerous movements, it is better to follow the suggested options.

Packed bushing

The case containing the bushings can be easily lifted with a tackle by applying the ropes on the points and with the inclination as indicated in fig.4. Some indications appear also in the packing case.

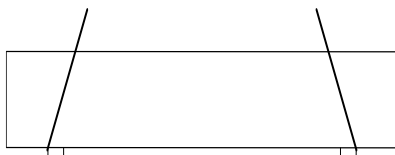

Fig. 4

Unpacked bushing

To take the bushing out of the case, operate as indicated in fig. 5a.

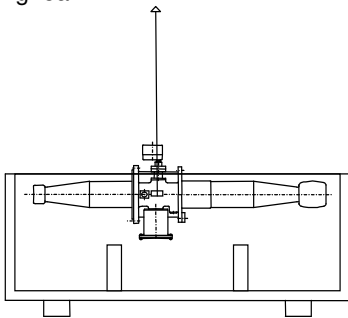

Fig. 5a

The best way to transport the unpacked bushing is to keep it in vertical position; be careful to place up the SF6 side (side with flange having thicker thickness). To lift the bushing, it is necessary to use the holes placed on the rib between the two flanges (see fig. 5b).

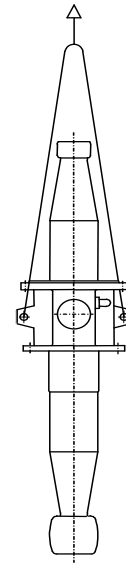

Fig. 5b

CAUTION

This is a delicate operation. Before to start the handling, be sure that the ropes are well fixed. Make all these operations only by EXPERT PEOPLE.

2.4 SHIPMENT TO THE END USER

Shipment of bushing made by the transformer manufacturer, after the transformer factory tests, has to be made either with the original packing or with a new one, made with the same concepts.

2.5 INSTALLATION ON THE TRANSFORMER

This type of bushing can be installed in the transformer in any position: vertical or horizontal or any other.

Beware to place the pressure gauge in visible position in order to check it during inspections.

In case of installation in horizontal the manufacturer suggests positioning the bushing in order to have the pressure gauge downwards: in this way, in case of outdoor installation, the pressure gauge is more protected from the weather.

HV connection, oil side, must be carried out as follows:

- Prepare the lower disk terminal according to fig. 6 (dimensions A, R and C must correspond to the oil side terminal dimensions of the bushing, as indicated in its outline drawing);
- Weld the connection coming from the transformer winding to the disk (fig. 6);



**OIL TO SF6 AND OIL TO OIL BUSHINGS
SERIES POBO/PCTO
VOLTAGE FROM 72,5 TO 765 kV**

IS 2541 GB

Page 6 of 13

Instruction Manual

Rev. G – August 2019

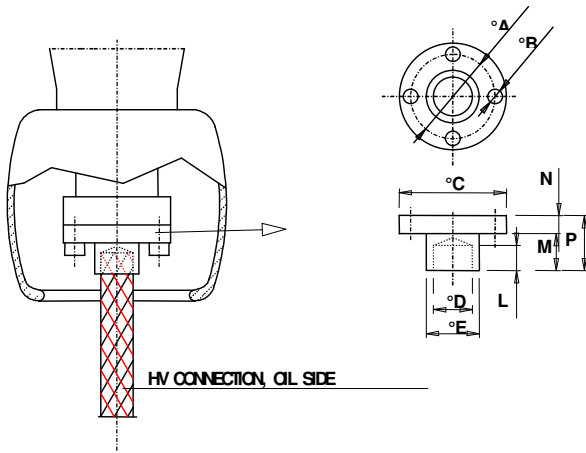

Fig. 6

- Insulate the connection in order to avoid gradient values (calculated at the power frequency withstand voltage) higher than those showed in fig.7;

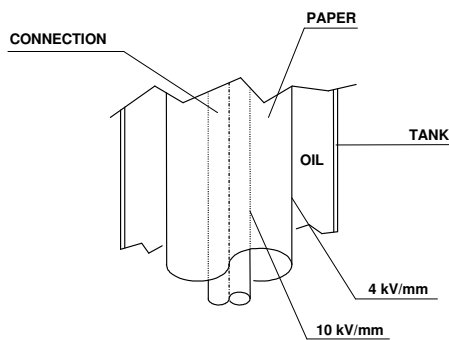

Fig. 7

- Remove the lower electrode of the bushing and introduce the connection;
- Clean carefully the bushing terminal surface with a rap lightly abrasive, in order to eliminate every trace of dirty, then clean with alcohol.
- Tighten with 4/8 screws the disk to the bushing with the torque indicated in table 1, depending on the screw type:

Screw type	Torque (N m)
M8	13
M10	25
M12	40

Table 1

- Mount the lower electrode;
- Install the bushing on the transformer cover interposing a suitable gasket.

The gasket which is necessary to assure the tightness between the bushing oil and the transformer one is not involved in this operation.

Dielectric shields

The ends of the bushing are shielded by suitable aluminium electrodes. They have the function of reducing the electric field both sides. These deflectors are removable to facilitate the connection. Normally they can be unscrewed downwards. In the 420 kV type, the oil side shield is bayonet type: it can be removed downwards rotating and pulling down its body.

To avoid any possible deflector's movement due to vibrations during service, an O-ring is placed in the thread.

If for mounting reasons the deflector shall be disassembled more than three times, it is better to substitute this O-ring with a new one.

CAUTION

During handling, take care to not damage the external finishing coat of the deflectors, important in the dielectric strength of the bushing oil side.

2.6 TEMPERATURE LIMITS

Bushings of the series POBO/PCTO are designed for operation at temperatures, according to IEC 60137, table 2:

- Ambient temperature max. $\leq + 40^{\circ}\text{C}$
- Daily average value. $\leq + 30^{\circ}\text{C}$
- Ambient temperature min. $\geq - 25^{\circ}\text{C}$
- Oil temperature average value. $\leq + 90^{\circ}\text{C}$
- SF6 temperature max. $\leq + 70^{\circ}\text{C}$

For special requirements regarding low ambient temperatures (up to -55°C) special O-rings are foreseen, made of nitrile mixtures for low temperatures. The spring closing system is calibrated in order to maintain the bushing hermeticity at these extreme conditions and the oil maintains its proprieties. For any other special or different condition please inform the manufacturer and ask the permission to put in service the bushings.

2.7 OIL FILLING OF TRANSFORMER

Bushings can withstand the vacuum conditions and temperature (up to 90°C) which occur during the treatment of the live part made inside the transformer case.

The oil filling level must reach at least the bushing flange, during the oil filling of the transformer under vacuum (for dielectric reasons).

In case the oil filling is made from the top of the transformer without the vacuum treatment, it is necessary to check that the oil level reaches the bushing flange, without the presence of air bubbles.



**OIL TO SF6 AND OIL TO OIL BUSHINGS
SERIES POBO/PCTO
VOLTAGE FROM 72,5 TO 765 kV**

IS 2541 GB

Page 7 of 13

Instruction Manual

Rev. G – August 2019

For this purpose, the flange is provided with a plug which allows the air (if present) to flow out.

CAUTION

The characteristic of withstanding vacuum and temperature refers to new bushings. In case of old bushings, it must be considered the natural derating and ageing of the gaskets

2.8 CONNECTION TO BUCHHOLZ RELAY

A 1/2" GAS plug is placed on the bushing flange (fig.8) in order to:

- connect the relay tube;
- eliminate the air pocket which may be formed during some executions and by the filling of the upper part of the transformer not under vacuum. In this case we suggest unscrewing the plug and leaving that the air flows out. When the oil begins to come out, please close it.

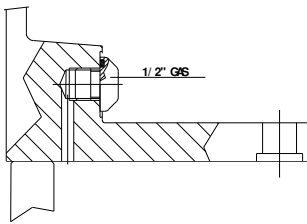

Fig. 8

2.9 INSTALLATION AND CONNECTION TO THE SF6/CABLE SIDE

The annular surface of the flange is machined with roughness degree of 1.6. Beware not to damage the surface during the mounting operations. Tighten with 4/8 screws the connection to the bushing SF6/cable flange with the torque indicated in table 1, depending on the screw type. The SF6/cable shield is supplied only for some types, so all the connection edges are to be shielded by the Customer. It is important that the connection is not rigid to avoid dangerous mechanical stresses generated by thermal material expansions. The SF6/cable sealing is made by an O-ring gasket in fluorinated rubber. We recommend adopting for it a diameter not lower than 6.99 mm.

3. SERVICE AND MAINTENANCE

3.1 METAL PARTS

The flange and the metallic components of the oil expansion vessel of the bushings are made of Aluminium alloy casting and do not require any special surface treatment / maintenance. Only in case of installation in aggressive environment (i.e.: coastal, high pollution, high salinity), it's

recommended to protect said metal parts with a layer of antirust coating.

3.2 CHECKS AFTER INSTALLATION

After the installation on the transformer it is advisable to make a check of the bushing capacitance and tgδ.

Normally the measurement must be carried out between the HV terminal and the Power Factor tap.

The capacitance values measured in manufacturer's HV laboratory are shown in the test report of the bushings.

During the operation, the connection tap must be grounded or directly by screwing the tap cap or through the measuring instrument connected to the power factor tap.

The PF tap is schematised in fig.9.

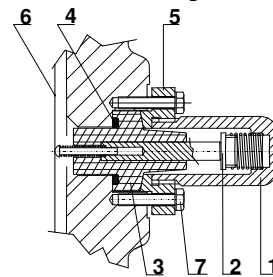

- 1 - Closing and grounding cap (removable)
- 2 - Measurement electrode
- 3 - Insulating bushing
- 4 - Gaskets
- 5 - Mounting flange
- 6 - Last layer
- 7 - Fixing screw (irremovable)

Fig. 9

Power factor tap (standard)

WARNING

Don't unscrew the screws item 7 of fig.9, that fix the PF flange to the bushing. If accidentally this operation happens some oil goes out from the bushing and the electrical contact between the internal condenser body and the flange can be damaged.

3.3 MAINTENANCE

The bushings POBO/PCTO are hermetically sealed and therefore an excellent preservation in time of the dielectric properties of the oil paper is ensured. As for the preservation of the active part, these bushings require no maintenance.



**OIL TO SF6 AND OIL TO OIL BUSHINGS
SERIES POBO/PCTO
VOLTAGE FROM 72,5 TO 765 kV**

IS 2541 GB

Page 8 of 13

Instruction Manual

Rev. G – August 2019

WARNING

The PF tap has to be grounded during the normal operation of the bushing.

Do not apply voltage to the bushing if the PF cap is removed. The cap grounds the tap connection.

It is advisable to check that the cap of the PF tap (see fig.9) is well screwed. A forgetfulness of this generates during service a voltage on the tap that exceeds the insulation dielectric strength: this may lead to a catastrophic failure.

It is recommended to perform every 5 years the measurement of the dielectric losses ($\text{tg}\delta$) following the instruction under par. 5.

It is only recommended to check every year that no oil leakages from the flange occur and that the internal pressure level, indicated by the manometer (if present), is normal, that is it doesn't go out of the permitted range (see curves in fig. 11,12 and 13).

Check the proper location of the tap cap and its suitable complete screwing in order to prevent entrance of moisture.

3.4 PRESSURE GAUGE - ALARM DEVICE

The bushing is equipped with a pressure gauge (Fig.10), installed on the flange, at least with two electrical contacts, one of minimum and one of maximum pressure, in order to signal any irregular pressure inside the bushing, caused by oil leakage or SF6 infiltration inside the bushing or anomalous operation temperatures.

The operation diagram of the two independent alarm contacts is indicated in the pressure gauge quadrant. If requested the pressure gauge can have more contacts, all independent:

- Three contacts, one of minimum and two of maximum pressure (alarm and block);
- Four contacts, two of minimum and two of maximum pressure (alarm and block).

The pressure value of the electrical contacts (alarm and block) is adjusted and checked in the factory at the values indicated in table 2.

The oil pressure in the bushing obviously depends on the temperature.

During the factory calibration the pressure is put at 0.7-1.2 bar relatives at 20 °C, depending on the class of the bushing.

	2 contacts	3 contacts	4 contacts
Minimum pressure, block	0.2 bar rel	0.2 bar rel	0.2 bar rel
Minimum pressure, alarm			0.4 bar rel
Maximum pressure, alarm		2.6 bar rel	2.6 bar rel
Maximum pressure, block	2.8 bar rel	2.8 bar rel	2.8 bar rel

Table 2

For other temperatures one can refer to the diagrams annexed, in which there is a band of possible values of pressure for every class of bushing (170 kV, 245 kV, 420 kV).

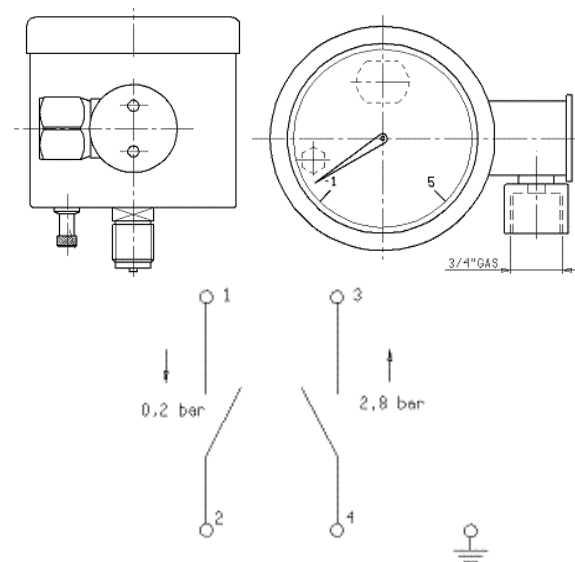

Fig. 10

WARNING

The bushing is fully filled with oil and is provided with one or more metal bellows for the compensation of oil volume variations due to the temperature changes during the operation. Bellows are placed into special cases located on the flange, fully immersed in the oil of the bushing. These cases are not to be opened for any reason (a special adhesive warning yellow label is provided as reminder).

WARNING

The manometer is connected to the bushing flange through a rotary valve. Don't close this valve (sealed with lead) rotating its cap. Leave the valve in the position initially put in manufacturer's factory



OIL TO SF6 AND OIL TO OIL BUSHINGS SERIES POBO/PCTO VOLTAGE FROM 72,5 TO 765 kV

IS 2541 GB

Page 9 of 13

Instruction Manual

Rev. G – August 2019

4. DISASSEMBLY OF THE BUSHING

To disassembly the bushing, operate according to the constructive solution adopted for the transformer, in parallel with the following suggestions:

- Bring the oil until a level lower than the bushing flange;
- Remove the top and bottom connections;
- Fix the bushing like indicated in par. 2.3;
- Remove the bolts that fix the flange;
- Finally lift the bushing following the indication given in par. 2.3.

5. MEASUREMENT OF DIELECTRIC LOSSES

Standard - IEC Publication 60137 - states that the oil-paper bushings must have a $\tan\delta$ less than 7×10^{-3} . Standard IEEE C57.19.01 states that the oil paper bushing must have a $\tan\delta$ less than 5×10^{-3} .

The measurement is performed in our Test Laboratory by means of a Schering bridge (Tettex type) at the voltages requested by the Standards.

All values are shown in the Test Report.

Measurement at the voltage of 10 kV is carried out in order to have a reference value for comparison with measurements made at site during the service of the bushing.

With the bushing already installed on the transformer and the SF6/cable terminal disconnected, the measurement can be performed by means of a bridge, by applying a voltage of 10 kV between the HV terminal and PF tap, maintaining grounded the flange (C1 measurement). The bushing is considered good if a $\tan\delta$ less than the maximum one established by the Standards is measured.

If a $\tan\delta$ higher than the above one is measured, please contact the manufacturer who will decide if it is necessary to make other tests before removing the bushing from service or to ship it back, in order to make a complete check and eventually to carry out an oil treatment or eventually to replace the active part with another of new manufacture.

In order to measure the C_o value (capacitance between the PF tap and flange) the flange has to be supplied with a voltage maximum of 2 kV and the PF tap has to be connected to the bridge.

A field measurement of $\tan\delta$ and capacitance can differ from the measurements carried out in the factory due to the different conditions of test and relevant accuracy: for this reason, a light shifting (max 10% for $\tan\delta$) is acceptable. Furthermore, the installation conditions can affect the capacitance value.

For this it is advisable to measure capacitance and $\tan\delta$ upon the installation and use these values as base for future comparison measurements.

6. CHECKS ON OLD BUSHINGS

Before remounting an old bushing, it is advisable to carry out the following checks:

- Check that no leakages occur on all the surface;
- Check that the internal pressure level, indicated by the manometer (if present), is normal, that is it doesn't go out of the permitted range (see curves in fig. 11, 12 and 13).

Electrical checks

They are suitable for service if, as regards the values of reception test, there are no increase higher than (note: values only indicatives):

- 1% for the capacitance C1 (this assure that there isn't a perforation between two layers)
- 30% for $\tan\delta$ of capacitance C1.
- 100% for $\tan\delta$ of capacitance C_o .

An increase of the last value means a derating of the dielectric characteristic of the external layers of the paper and/or of the oil in the interspace between the condenser body of the bushing and the external housing.

7. EXTRAORDINARY CHECKS

If the electric measurement detects a $\tan\delta$ higher than the limits it is suggested to carry out an oil sampling (See par. 8) and to perform the following tests:

- Humidity content;
- Dielectric strength;
- Dielectric losses;
- Gas chromatography.
- Humidity content:
 - Original value: ≤ 10 ppm
 - During working: ≤ 20 ppm
- Dielectric strength:
 - Original value: ≥ 62 kV/2,5 mm
 - During working: ≥ 45 kV/2,5 mm
- Dielectric losses ($\tan\delta$):
 - Original value: $\leq 7 \cdot 10^{-3}$
 - During working: $\leq 12 \cdot 10^{-3}$
- Gas chromatography (DGE):
 - Refer to Standards (IEC 60599, IEC TR 61464).

If these checks give negative results, it is necessary to ship back the bushing to the manufacturer who will perform a complete set of electrical tests and eventually will decide to make an oil treatment to the bushing or to replace the active part with another one of new construction.



**OIL TO SF6 AND OIL TO OIL BUSHINGS
SERIES POBO/PCTO
VOLTAGE FROM 72,5 TO 765 kV**

IS 2541 GB

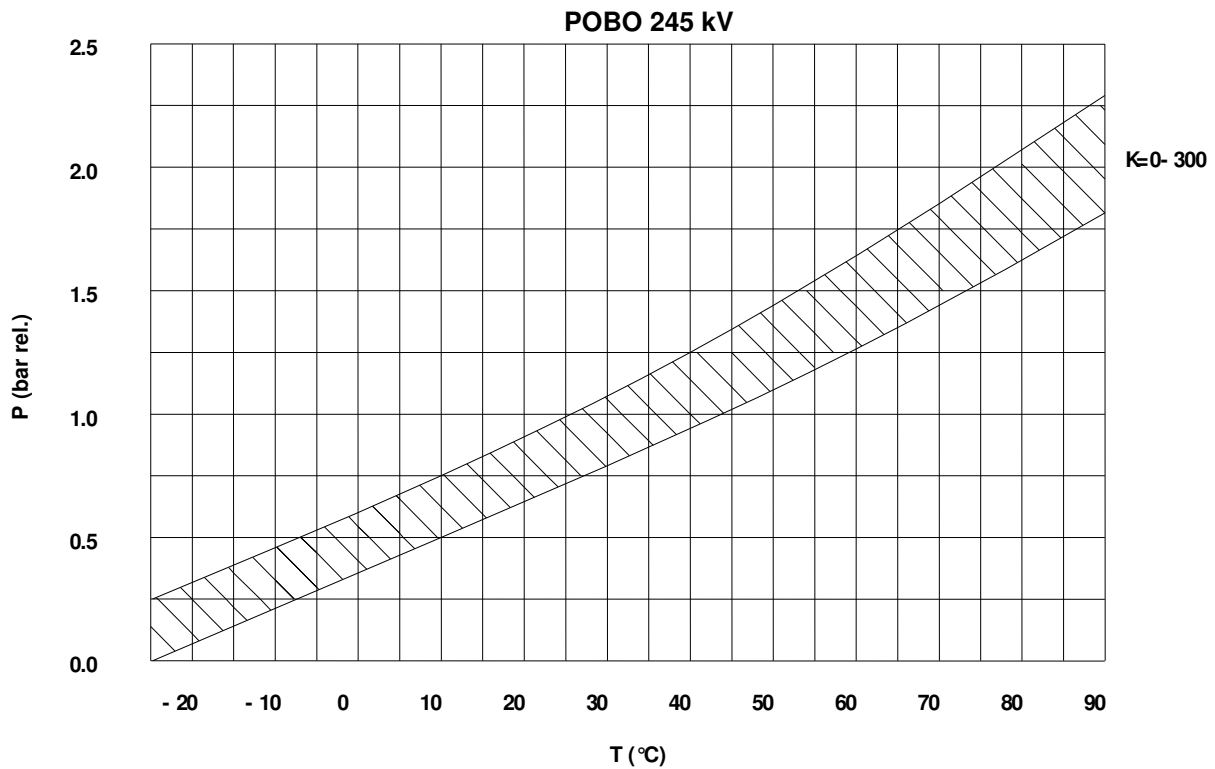
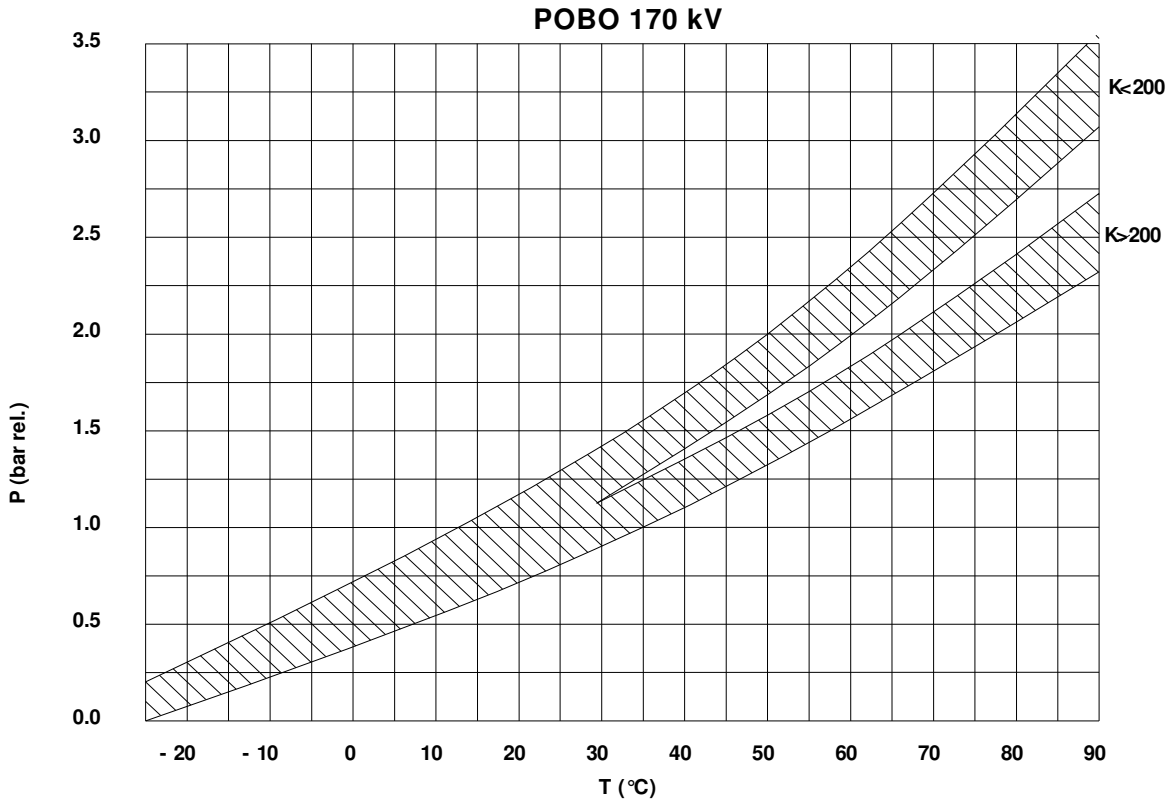



POBO 420-550kV

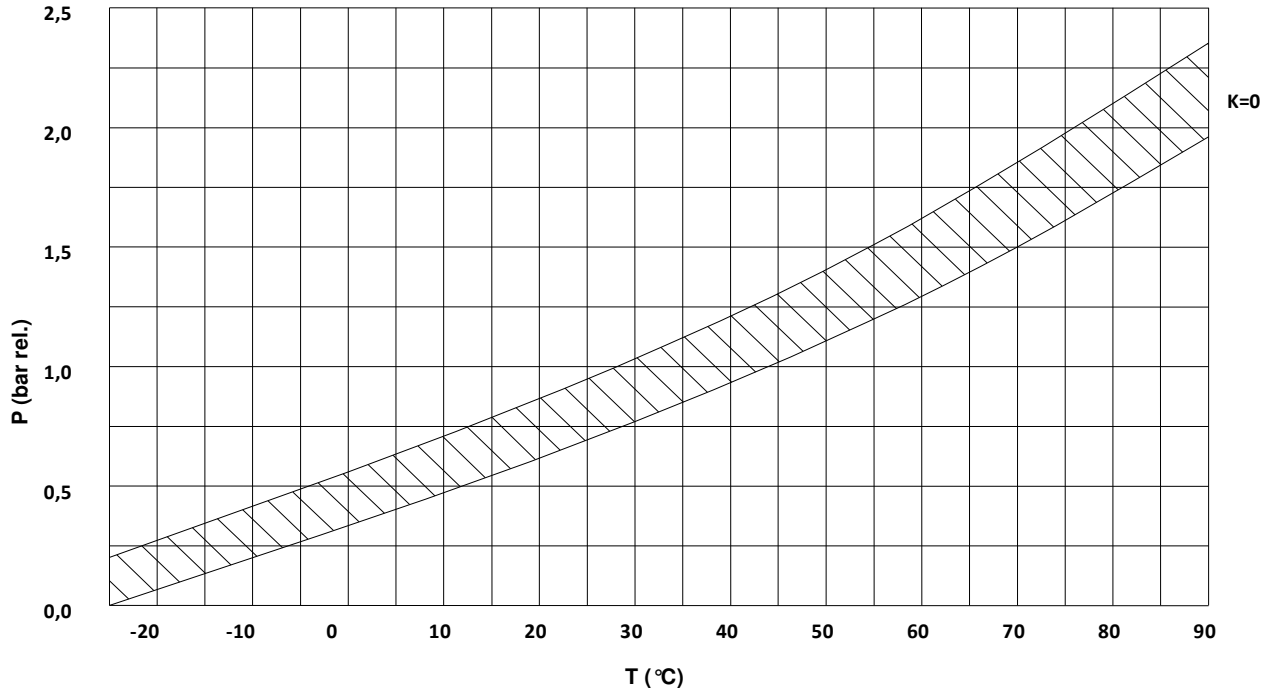

Fig. 13

8. OIL SAMPLING

8.1 EQUIPMENT

To carry out oil sampling, we need the following tools (see fig. 14):

- A semi-rigid pipe (item 3);
- A two-way cock (item 4) with a suitable connection to the syringe;
- A 150 cm³ oil syringe (item 5) (Lab. Type);
- An appropriate plug that can be screwed in one side at the cap placed on the side of the manometer's connecting flange and at the other side on the tube (item 2). Note that the manometer's flange hole has a thread of 1/4" GAS in new bushings, M6 in the old ones.
- A syringe cap;
- Adhesive tape.

8.2 OIL SAMPLING

The operation is to be carried out when the line is off.

Preparation

Operate as follows:

- Clean the plug zone accurately;

- Prepare all the syringe apparatus, with the cock (item 4) and the pipe (item 3);
- Close the valve (item 1) placed between the bushing's flange and the manometer;
- Unscrew the oil sampling plug and screw the connecting cap (item 2), on which the tube (item 3) is to be applied in sequence.
- Open the 2nd way of cock (item 4);
- Open the 1st way, shut off the 2nd way of cock (item 4);
- Open a little and slowly the valve (item 1), to let the oil go out from the bushing;
- Drain oil from the bushing letting it flow out until there are no more air bubbles;

WARNING

The syringe should be filled by means of the oil pressure and not by suction with plunger (as there would be risk of air suction).

- Shut off the 1st way and open the 2nd way of cock (item 4).
- Wash the syringe with oil two times by repeating the following operations:
 - Open 2nd way of cock (item 4);



**OIL TO SF6 AND OIL TO OIL BUSHINGS
SERIES POBO/PCTO
VOLTAGE FROM 72,5 TO 765 kV**

IS 2541 GB

Page 12 of 13

Instruction Manual

Rev. G – August 2019

- Fill in the syringe with some oil (about 10 cm³);
- Open 1st way of cock (item 4);
- Empty the syringe;
- Close 1st way of cock (item 4).

Oil sampling

For sampling please follow these instructions:

- Open 2nd way of cock (item 4);
- Let oil get in the syringe up to the appropriate volume (approx. 60-100 cm³);
- Shut off both 2nd way of cock (item 4) and the valve (item 1);
- Remove the syringe by unplugging the cock (item 4) from the tube (item 3);
- Set the syringe (item 5) with the cock (item 4) being up;
- Unplug the cock (item 4) and place a closing cap;
- Clean the syringe (item 5) and block it with adhesive tape on which you will write down the bushing part number;
- Overturn the syringe and keep it with its cap down.

Final operations

Operate as follows:

- Remove the pipe (item 3) from the plug (item 2), unscrew the plug and screw immediately but not completely its proper tap;
- Open slowly the valve (item 1) in order that oil push can allow the air near the tap to flow away;
- Once the air is flown away, the oil begins to go out. Close quickly the breathing screw (item 2) and clean from oil;
- Check that the valve (item 1) is completely open and seal it again.

Above mentioned operations involve on the whole a sampling of less then 0.20-025 litres of bushing oil. For bushings of 245 kV or higher it is possible to sampling oil only one time without restore it with new one. To make a new oil sampling, it will need a filling up of oil.

WARNING

For bushings up to 170 kV, it is possible to make oil sampling only one time, trying to take the smallest quantity of oil and making attention that the internal pressure doesn't go down the initial pressure more than 0,3 bar. If the internal pressure goes over this limit, it will need to fill up the oil (please contact the manufacturer to ask about the filling up of the oil: this is a very delicate operation)

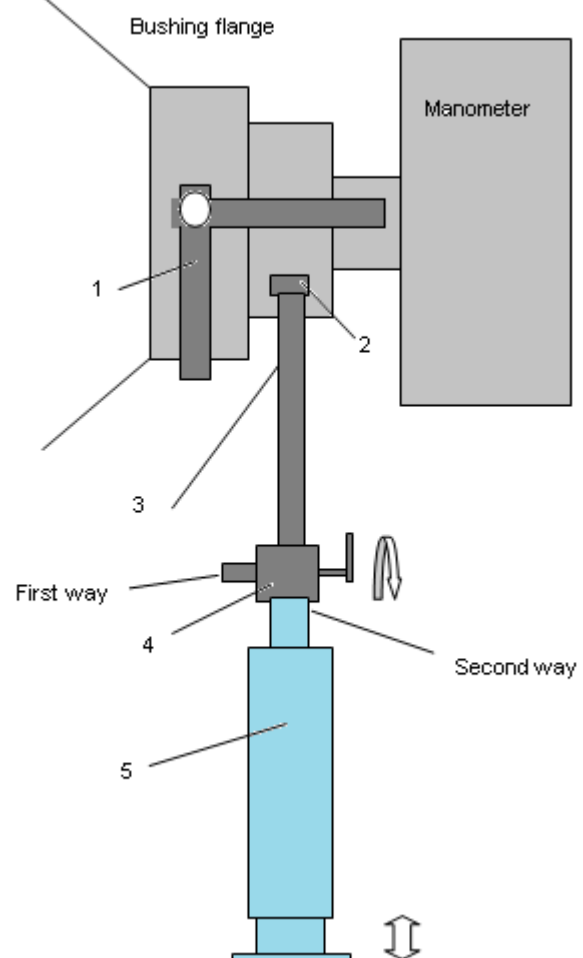

Fig. 14



**OIL TO SF6 AND OIL TO OIL BUSHINGS
SERIES POBO/PCTO
VOLTAGE FROM 72,5 TO 765 kV**

IS 2541 GB

Page 13 of 13

Instruction Manual

Rev. G – August 2019

9. Disposal at the end of lifetime

The bushing consists of the following material:

Component	Material	Action
Winding conductor	Copper or aluminium alloy	Dismount and recycle
Terminals and bottom plates	Copper, aluminium alloy or brass; optional silver or tin coating	Dismount and recycle
Insulating oil	Mineral oil acc. IEC60296	Recycle
Winding	Cellulose paper and thin aluminium foils	Dispose or thermo-destruction
Nuts, bolts, washers and springs	Stainless steel, carbon steel	Dismount and recycle
Oil expansion bellows and covers	Stainless steel and aluminium alloy	Dismount and recycle
Flange and extension	Aluminium alloy	Dismount and recycle
PF tap and cover	Nickel or tin coated brass, tin coated copper, stainless steel	Dismount and recycle
Insulators	Porcelain acc. IEC60672	Dispose
Shields	Aluminium alloy covered with either epoxy paint or epoxy resin	Dismount and recycle