

# T155 Dual Gas

## 420 kV (63 kA, 5,000 A) Gas-Insulated Substation Compatible with SF<sub>6</sub> or g<sup>3</sup> gas

GE has more than 50 years of experience in the design, material selection, development, engineering, manufacturing, and servicing of gas-insulated substations (GIS).

Our T155 Dual Gas GIS bay – compatible with either SF<sub>6</sub> or g<sup>3</sup> gas – meets the challenges of networks up to 420 kV for power generation, transmission, and energy-intensive industry applications.

### Future-proofed for flexibility

Anticipating future SF<sub>6</sub> regulations, this dual gas equipment is available with either SF<sub>6</sub> or g<sup>3</sup>. Because of its identical foundational design, transmission system operators can utilize the SF<sub>6</sub> version today and easily make the switch to GE's g<sup>3</sup> solution at a later time.

All bay components, except the circuit breaker, are g<sup>3</sup> or SF<sub>6</sub> compatible. They have been type tested to demonstrate the same performances and ratings with both gases.

### The environmental advantage

The T155 is available in a fully SF<sub>6</sub>-free version using GE's g<sup>3</sup> technology, allowing for a 99% CO<sub>2</sub> reduction. While it has the same performance and ratings as SF<sub>6</sub>, its advanced sealing system and improved tightness reveal a lower environmental impact.

### A universal solution

The design of GE's T155 Dual Gas GIS is grounded in more than 50 years of field experience in SF<sub>6</sub> and five years in g<sup>3</sup> technology. Its fully digital monitoring control and protection capabilities enable easy implementation processes and the same operational and maintenance procedures.

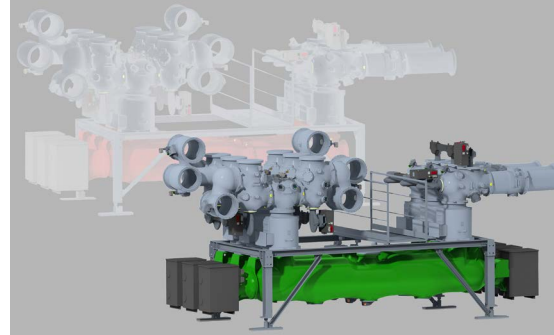

### Improved Sustainability

- Lower carbon footprint during a 40- year substation life cycle
- First-in-class gas sealing system
- Improved tightness due to sealing length divided by two, compared to the previous version
- The gas contribution to global warming is reduced by 99% using GE's g<sup>3</sup> gas instead of SF<sub>6</sub>

### Smart Grid Features

- Fully digital monitoring, control, and protection
- Digital power sensing using low power instrument transformers

### Easy Upgrades

- Bays are completely factory-assembled, wired, and tested before shipment
- Easily make the switch to SF<sub>6</sub>-free whenever you're ready
- Similar operational and maintenance procedures as with SF<sub>6</sub> GIS for simple integration
- Compact design that's applicable to all substation applications, including extension of existing substations
- State-of-the-art maintenance isolating device



## Specifications (\*)

| GIS TYPE  | g <sup>3</sup><br>T155g 420 kV   | Combined g <sup>3</sup> bay-SF <sub>6</sub> CB<br>T155 420 kV | SF <sub>6</sub><br>T155 420 kV   |
|---|----------------------------------|---|----------------------------------|
| Reference electrotechnical standards  | IEC                              | IEC/IEEE  | IEC/IEEE                         |
| Rated voltage   | 362-420 kV                       | 362-420 kV  | 362-420 kV                       |
| Withstand voltages  |                                  |   |                                  |
| Short-duration power-frequency, phase-to-earth/across open switching device | 650/815 kV                       | 650/815 kV  | 650/815 kV                       |
| Switching impulse, phase-to-earth / across isolating distance               | 1050/900(+345) kVp               | 1050/900(+345) kVp  | 1050/900(+345) kVp               |
| Lightning impulse, phase-to-earth / across open switching device            | 1425/1425(+240) kVp              | 1425/1425(+240) kVp   | 1425/1425(+240) kVp              |
| Frequency   | 50 Hz                            | 50/60 Hz  | 50/60 Hz                         |
| Continuous current  | up to 5000 A                     | up to 5000 A  | up to 5000 A                     |
| Short-time withstand current  | 63 kA                            | 63 kA   | 63 kA                            |
| Peak withstand current  | 170 kAp                          | 170 kAp   | 170 kAp                          |
| Duration of short-circuit   | 3s                               | 3s  | 3s                               |
| Installation  | indoor/outdoor                   | indoor/outdoor  | indoor/outdoor                   |
| <b>Circuit Breaker Ratings</b>  |                                  |   |                                  |
| First-pole-to-clear factor  | 1.3-1.5                          | 1.3-1.5   | 1.3 - 1.5                        |
| Short-circuit breaking current  | 63 kA                            | 63 kA   | 63 kA                            |
| Short-circuit making current  | 170 kAp                          | 170 kAp   | 170 kAp                          |
| Operating sequence  | O-0.3s-CO-3 min-CO/<br>CO-15s-CO | O-0.3s-CO-3 min-CO/<br>CO-15s-CO                              | O-0.3s-CO-3 min-CO/<br>CO-15s-CO |
| Drive type  | Pure-spring                      | Pure-spring   | Pure-spring                      |
| Mechanical endurance  | M2 class                         | M2 class  | M2 class                         |
| Capacitive switching  | C2 class                         | C2 class  | C2 class                         |
| <b>Disconnecter and Low-speed Earthing Switch Ratings</b>                   |                                  |   |                                  |
| Capacitive current switching  | 0.5 A                            | 0.5 A   | 0.5 A                            |
| Bus-transfer current switching capability                                   | 3000 A / 25 V                    | 3000 A / 25 V   | 3000 A / 25 V                    |
| Mechanical endurance  | M2 class                         | M2 class  | M2 class                         |
| <b>Make-proof Earthing Switch Ratings</b>                                   |                                  |   |                                  |
| Making current capability   | 170 kAp                          | 170 kAp   | 170 kAp                          |
| Switching capability-electromagnetic coupling                               | 160 A / 10 kV                    | 160 A / 10 kV   | 160 A / 10 kV                    |
| Switching capability-electrostatic coupling                                 | 18 A / 20 kV                     | 18 A / 20 kV  | 18 A / 20 kV                     |
| Mechanical endurance  | M1 class                         | M1 class  | M1 class                         |

(\*) typical ratings, other values on request

## GEGridSolutions.com

IEC is a registered trademark of Commission Electrotechnique Internationale.

GE, the GE monogram, g<sup>3</sup> and g<sup>3</sup> logo are trademarks of General Electric Company

GE reserves the right to make changes to specifications of products described at any time without notice and without obligation to notify any person of such changes.

Copyright 2023, General Electric Company. All Rights Reserved.

