



For high speed phase and ground protection of power transformers and autotransformers.

Features and Benefits

- Adjustable restraint slope
- Inherently selective
- Drawout case

Applications

- Power and autotransformer protection
- Current differential single phase
(3 required per transformer)

Protection and Control

- High speed percentage differential
- Harmonic restraint
- Hinged armature instantaneous unit



Description

The STD is a harmonic restrained percentage differential relay specifically designed for transformer fault protection. The STD15 through 21 relays differ from each other only in the number of restraint circuits that they include (see Selection Guide). The STD25 through 29 relays differ from STD15 through 21 relays in that they utilize only second harmonics for the harmonic restraint circuit while the others use all the harmonics. Harmonic restraint is employed to prevent undesired tripping as a result of exciting current inrush to the transformer being protected. Inrush to a transformer usually occurs when the transformer is energized or when a nearby fault is cleared thus suddenly restoring normal voltage to the bank. The second harmonic component is the predominant harmonic transformer inrush current.

Application

In general the STD relays are recommended for application wherever it is desired to provide high speed transformer differential protection that is secure against undesired operations on transformer inrush currents. The STD15 through 21 relays produce harmonic restraint from all harmonics and are thus better suited for use throughout the system where the normal harmonic content is insignificant. Specifically, the STD25 through 29 relays are recommended for use on rectifier transformers where relatively high levels of odd harmonics are normally present. Since these relays produce harmonic restraint on

second harmonic currents only they will be unaffected by the odd harmonics generated by the load.

For best performance it is recommended that a separate restraint be used for each set of CT's employed. For example, for a two winding transformer, the two restraint STD15 would suffice. For a three winding transformer (with all three windings loaded) the three restraint STD16 should be used. When a transformer is connected to a ring bus, it is very desirable to have a separate restraint for each of the two associated breakers. For example, a two winding transformer connected to a ring bus on the high side and the low side would best be protected with a four restraint STD17.

In general, it is best to use one set of relays for each transformer to be protected. While it is possible to protect two or more transformers (all switched together) with one set of relays, this results in less sensitive protection as well as a lack of indication of the faulted transformer. When two or more transformers are to be switched separately, it is not recommended that one set of relays be used to protect all of them. This is so because a transformer suddenly energized tends to take the harmonic components of the inrush current from the parallel banks while the fundamental component comes from the system. With only one set of relays protecting two or more banks the harmonic restraint circuit of the relays will not see the harmonic currents. Thus, no harmonic restraint is produced and an undesired trip of all the transformer banks may result

from the fundamental component of the inrush that is seen by the relays as operating current.

The through restraint circuits of all the STD relays are continuously adjustable in the range of 15 thru 40 percent slopes. The slope employed should be selected on the basis of the matching between the CT ratios and the taps on the relay. Each restraint circuit has 8 taps between 2.9 and 8.7 A so that on power transformers with fixed taps it is possible to match to within about 5 percent. When protecting load tap changing transformers it will generally not be possible to match taps on the relay to within 5 percent over the complete range of the power transformers. The higher slope settings should be used for these applications.

Contacts

The STD relays are furnished with one normally open contact. The current closing rating of the contact is 30 A for voltages not exceeding 250 V. After tripping occurs, it is necessary that the tripping circuit of these relays be opened by an auxiliary switch on the circuit breaker or by other automatic means.

If more than one circuit breaker per contact is to be tripped, or if the tripping current exceeds 30 A, an auxiliary relay must be used in conjunction with the STD relay. A hand-reset relay such as the HEA is recommended and normally used.

Connection Diagram

Fig. 1 Elementary diagram for the STD-16 relays for four-circuit transformer protection with three restraints

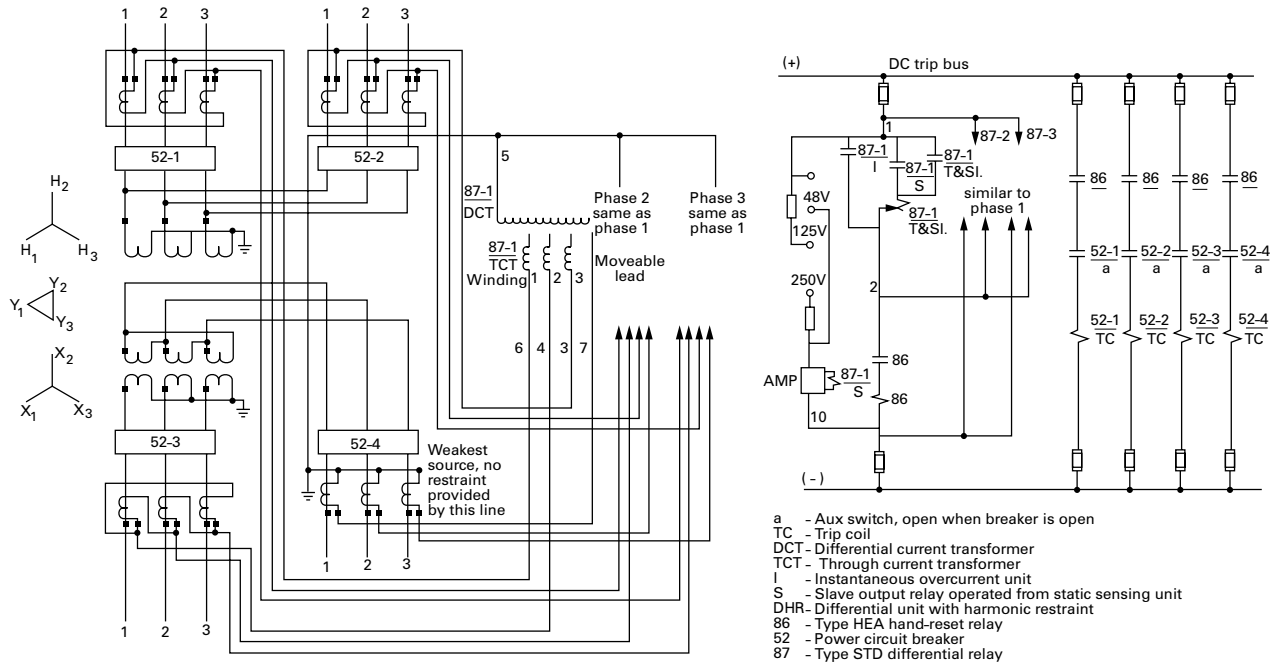

Burdens

All STD Relays

Tap Setting (A)	Zero-Restraint Pickup ^③ (A)	Operating Circuit ^① 60 Hz Relays ^②		Restraint Circuit 60 Hz Relays ^②	
		Burden VA	Imped Ω	Burden VA	Imped Ω
2.9	0.87	3.2	0.128	1.3	0.052
3.2	0.96	2.7	0.108	1.2	0.048
3.5	1.05	2.4	0.096	1.1	0.044
3.8	1.14	2.0	0.080	1.0	0.040
4.2	1.26	1.9	0.076	0.9	0.036
4.6	1.38	1.6	0.064	0.8	0.032
5.0	1.50	1.5	0.060	0.7	0.028
8.7	2.61	0.7	0.028	0.5	0.020

① Burden of operating coil is zero under normal conditions.

② Burden of Hz relay is the same or slightly lower.

③ It should be recognized that pickup flows not only through differential current transformer but also through one of the primary windings of the through current transformer producing some restraint, however, compared to the operating energy, this quantity of restraint is so small that it may be assumed to be zero.

NOTE: Burdens and minimum pickup values are substantially independent of the percent slope settings and are all approximately 100 percent power factor. figures given are burdens imposed on each current transformer at 5.0 A.

Selection Guide

Single Phase

No. Rest. Wind.	Amps	Frequency (Hz)	Slope (%)	DC Control (V)	Target & Seal-in (A)	Min P.U. (A) ①	Model Number	Cont.	Case Size	Approx. Wt. in lbs (kg)	
										Net	Ship

RESTRAINT ON ALL HARMONICS

2	5	60	15/25/40	48/125/250	0.2/2.0	1.5	12STD15C5A	1 N.O.	M1	24 (10.9)	34 (15.4)	
		50			0.6/2.0		C3A					
		60			0.2/2.0		C6A					
0.6/2.0					C4A							
60		0.2/2.0			12STD15D3A		2 N.O.					
3		60			48/110/220		0.2/2.0					12STD16C5A
		50		0.6/2.0			C3A					
				0.2/2.0			C7A					
		0.6/2.0		C6A								
4		60		48/125/250	0.6/2.0		12STD17C2A	1 N.O.		L2		
		50			C3A							
5		60		48/110/220	0.6/2.0		12STD18C2AC				1 N.O.	L2
	50	3A										
	50	C4A										
8	60	48/125/250	0.6/2.0	12STD21C1A	1 N.O.	L2						
				38 (17.2)			51 (23.1)					

RESTRAINT ON 2ND HARMONIC ONLY

2	5	60	15/25/40	48/125/250	0.6/2.0	1.5	12STD25D2A	1 N.O.	L1	29 (13.1)	42 (19)
3		60			0.6/2.0		12STD26C1A			31 (14)	44 (20)
5		60			0.2/2.0		12STD28C2D			37 (16.8)	50 (22.7)
					1.0		C1D				
6	60	0.2/2.0	12STD29C2D	39 (17.7)	52 (23.6)						
			0.6/2.0			C1D					

① Minimum pickup is 1.5 A for the 5 A tap and 25 percent slope setting.

