

SPOL

Vertical Break Folding Arm Disconnect Switch From 245 kV to 800 kV

GE's disconnect switches are the result of over 75 years of experience in developing high voltage switches that have proven their reliability in the scorching climates of Arizona (USA), Australia and Sudan, in the extremely cold territories of Canada, Russia and Sweden, in the tropical weather of Panama, Indonesia, Malaysia and Venezuela and in regions with intense seismic activity such as Chile and California (USA).

Compact Design

The SPOL disconnect switch is a rugged performer even in the most adverse operating conditions. The SPOL is designed with a folding arm which allows the blade sections to fold in on themselves in a vertical plane and in the open position. The overall height of the arm in the open position is only 60% of the longitudinal dimension. As a consequence, substation crossing structures and wires can be lower and less expensive than using conventional vertical break disconnect switches. The center of gravity of the live part is always much lower than on a conventional vertical break disconnect switch, meaning better performance during an earthquake as well as faster, smoother and rebound-free operations.

Unique L-Contact

The SPOL is equipped with the GE's unique L contact designed for switches used in heavily polluted or iced sites and for disconnect switches where an extended mechanical endurance (10,000 operations) is required.

Reliable Performance

Rotation of the insulator causes the blade to unfold in such a way that the protected tulip contact rises in a straight horizontal path to close the switch. When engaging the fixed contact, the mobile arm enters the guiding bell and the fixed contact matches the mobile one. The blade is counter-balanced so that only friction forces must be overcome when operating the switch.



Superior Manufacturing

GE is one of the leading, global suppliers of disconnectors. The design principles, the technical know-how and experience of the GE experts and the careful selection of suppliers ensure that only top quality materials are used during production, ensure an excellent life cycle cost.

Certified Quality

- All GE's disconnect switch manufacturing sites worldwide are certified according to ISO 9001, ISO 14001 and OHSAS 18001.
- GE designs, manufactures, tests and delivers its disconnect switches in accordance with the latest ANSI and IEC standards, as well as GB Chinese national standards.

Key Benefits

- Pollution and ice-free L contact
- Reduced vertical space requirements
- Built-in or retro-fitted ground switches
- Built-in arcing and bus transfer contacts
- Virtually maintenance-free
- Easy start-up and commissioning



Installation and Maintenance

The SPOL does not require any special tools to be adjusted and is recognized worldwide as easy to install and adjust.

The SPOL is virtually maintenance-free thanks to its lifetime greased or self-lubricating parts and corrosion-free materials.

Optional Devices

The SPOL is fitted with bus transfer contacts. The integrated ground switches used on double circuit overhead lines can also be fitted with induced current switching devices (IEC 62271-102 Annex C). For extra high voltage applications, a specific spark-free solution with an SF₆ breaking chamber grants the maximum safety for personnel in the substation.

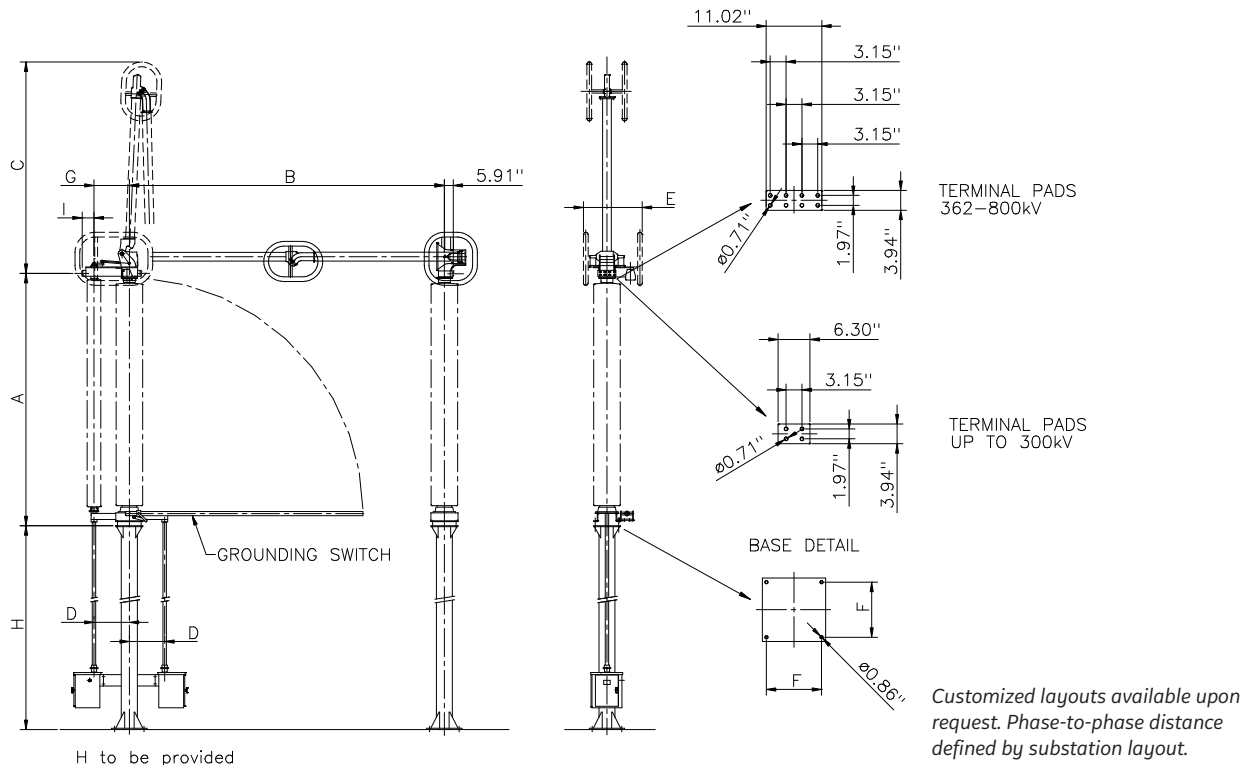

Technical Data (ANSI)*

Rated voltage kV	Rated current A / Short time current kA	BIL kV	A inches	B inches	C inches	D inches	E inches	F inches	G inches	H inches
245	4,000 / 63	1,050	8' 4¼"	9' 10"	5' 7"	1' 4¾"	1' 7¾"	1' 1½"	1' 11¼"	6¾"
362	4,000 / 63	1,300	9' 9½"	12' 1¾"	7' 8½"	1' 11½"	2' 7½"	1' 3¾"	2' 7½"	7¾"
550	4,000 / 63	1,800	13' 7½"	17' 6¾"	9' 4¼"	1' 11½"	3' 3¾"	1' 3¾"	2' 7½"	7¾"
800	4,000 / 63	2,050	17' 1¼"	19' 8¼"	12' 7½"	1' 11½"	3' 3¾"	1' 3¾"	2' 7½"	245

* IEC ratings also available

For more information please contact
GE
Grid Solutions

Worldwide Contact Center

Web: www.GEGridSolutions.com/contact
Phone: +44 (0) 1785 250 070

GEGridSolutions.com

IEC is a registered trademark of Commission Electrotechnique Internationale.
IEEE is a registered trademark of the Institute of Electrical Electronics Engineers, Inc.

GE and the GE monogram are trademarks of General Electric Company.

GE reserves the right to make changes to specifications of products described at any time without notice and without obligation to notify any person of such changes.

SPOL_ANSI-Brochure-EN-2019_01-Grid-AIS-0077. © Copyright 2019, General Electric Company.



Imagination at work