



For high speed differential protection of busses and feeders and shunt reactors.

Features and Benefits

- Static circuitry
- Variable DC control voltage
- Output isolation with telephone relay
- Target seal-in unit
- Drawout case

Applications

- Bus and feeder differential protection
- Shunt reactor differential protection

Protection and Control

- Sensitive, high-speed differential protection
- Phase and ground fault detection (requires 3 relays)
- Breaker failure initiation when used with a suitable timing relay
- High impedance voltage measurement with overcurrent supervision



Description

The SBD11B is a single-phase, high-speed differential relay. It is specifically designed to provide bus differential protection, but may also be used for differential protection of shunt reactors. A high impedance, voltage measuring circuit with overcurrent supervision is used for fault detection. The utilization of static circuitry results in very short operating times. Output isolation is obtained with a telephone-relay, and a target seal-in unit is provided. A voltage selecting link allows the relay to operate on 48, 125, or 250 VDC. The relay is packaged in an S-2 drawout case and requires no auxiliary CT's.

Application

The SBD11B relay is intended to be applied where sensitive, high-speed differential protection is required; and where severe CT saturation can occur for internal and external faults. The current transformers used with the relay should have fully distributed windings. The SBD can be applied with multi-ratio CT's, provided all CT's are on the same tap (see current transformer requirements).

A conventional differential relay circuit is used with the SBD11B relay connected in parallel with all the current transformer secondaries of each phase (see Figure 1). Complete protection for phase and ground faults requires three single-phase SBD11B relays plus one lockout auxiliary relay, HEA, having three normally open contacts in addition to those which are required for tripping circuit breakers. The auxiliary contacts short out a portion of the input circuit after a trip has been initiated. This allows the relay to operate as a straight overcurrent function following lockout relay operation and at the same time insures that the short time rating of the relay is not exceeded. Thus, the SBD11B may be used to initiate a breaker failure timer.

The high-impedance, voltage-actuated operating principle is used in the SBD11B relay design. For normal conditions, the differential connection of the CT's results in negligible voltage across the relay. During an internal fault, the unbalance in CT currents produces a voltage above relay pickup, resulting in operation. Severe external faults, even those which result in complete CT saturation, will not produce sufficient voltage across the relay to cause operation. This selectivity is always possible because of the low DC resistance of the CT winding when saturated and its comparatively high magnetizing impedance.

The SBD relay is set by calculating the required voltage and current taps. The objective is to select the lowest available taps which are secure from misoperation for external faults. This will provide maximum relay sensitivity for internal faults. Needed for this calculation are estimates of the maximum fault current available at the bus, and the resistances of the current transformers and the wiring connecting them to the junction point. The relay instruction book fully describes the recommended procedure to set the relay using this information and provides sample calculations.

Operating time for the SBD relay is typically from 5 to 8 ms. The sensitivity level for internal faults as determined by the voltage tap setting will depend on CT excitation characteristics and the number of circuits involved. Recommended practices to insure maximum relay sensitivity are contained in the instruction book, which should be consulted before applying the relay.

Where lightning arresters are located within the zone protected by the relay, the SBD11B2A model should be selected.

Current Transformer Requirements

1. While a mixture of multi-ratio current transformers may be used, it is essential that the taps used result in all of the CT's having the same ratio. Where part winding taps are employed, it should be insured that the voltage developed across the full winding due to auto-transformer action does not exceed the CT hi-pot rating. Otherwise, no special calculations or equipment are required when mixed ratio CT's are used.
2. All current transformers should have fully distributed windings. The full winding should be used where possible, but tapped windings can be used if they are also distributed, as they are on General Electric bushing CT's. If the CT's do not meet this requirement, the instruction book describes a method to apply the SBD11B provided the leakage reactance is known.
3. The use of dedicated CT's is recommended. The application of other devices in the SBD current transformer circuits will result in less sensitive protection.

Contact Ratings

Three electrically separate, normally open contacts from the output telephone relay are furnished. One of these contacts is provided with a target and seal-in unit.

The spare normally open contacts will make 30 A for tripping duty, and will make and carry 30 A continuously. The interrupting ratings are as shown in the table to the right.

Volts	Interrupting Ratings (A)	
	Ⓢ Inductive	Non-inductive
AC		
115	0.75	2.0
230	0.5	1.0
DC		
48	1.0	3.0
125	0.5	1.5
250	0.25	0.75

Ⓢ Inductance with L/R ratio of 0.1 sec.

AC Current Ratings

- Continuous—10 A RMS
- 1 Second—160 A RMS (Symmetrical)
- 5 Cycles—480 A RMS (Symmetrical)
- 2 Cycles—215 A RMS (Fully Offset)

Connection Diagram

Fig. 1. Typical elementary diagram for the SBD11B relays for a three breaker bus (0246A6979, 80)

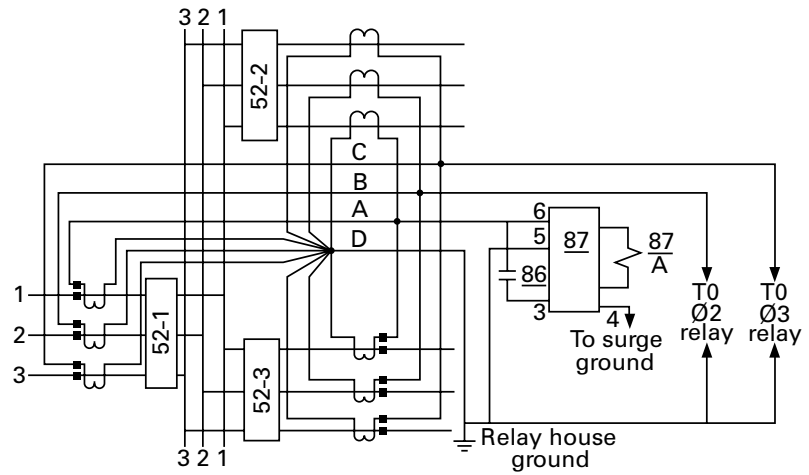

Legend			
Device No.	Device Type	Elem.	Description
87	SBD11		Single phase high impedance differential relay
		A	Output telephone relay
		TSI	Target and seal-in unit
86	HEA		Lockout relay

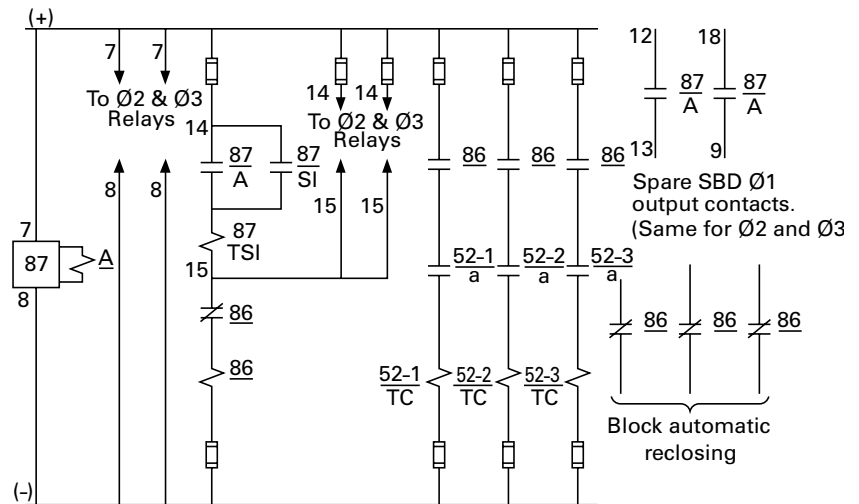

Selection Guide

Single-phase

Frequency (Hz)	Voltage Adjustment Range	Current Taps	Target and Seal-in Amps	DC Control Volts	Model Number	Case Size	Approx. Wt. in lbs (kg)	
							Net	Shipping
50/60	50-350	0.5/1.0 0.5/2.5	0.2/2.0	48/125/250	SBD11B1A B2A	S2	14(6.4)	20(9.1)