

# PCTR

## Condenser Bushing 72.5kV - 420kV Oil-Oil Application Resin Impregnated Paper Bushing

PCTR bushings are capacitance graded type (bushings made) manufactured with Resin Impregnated Paper insulation (RIP-dry type). They are designed for use on power transformers to connect two oil environments, in compliance with latest editions of IEC 60137.

Design, components and manufacturing technology of the RIP bushings can guarantee an average lifetime of 30 years under normal operating conditions. Being dry type RIP bushings, they offer benefits compared with conventional bushings (oil, gas, etc.) mainly in terms of the safety, environment protection and maintenance-free products.

### Manufacturing of Capacitance-graded Bushings

The main electrical insulation consists of a condenser core made of a continuous sheet of pure dried crepe paper and aluminum foils wound around a conductor rod/tube made of aluminum or copper, designed according to customer specification.

The paper is pre-dried by heated cylinders and infra-red rays during winding process; the water content is reduced to less than 1%. During the winding stage, the aluminum foils are inserted coaxially between paper layers to create a co-centric cylindrical condenser core.

The graded bushing technology assures a uniform distribution of the electrical field between high voltage conductor and earthed parts (like) such as the main aluminum flange used for fitting on the transformer and the test tap used to earthing the last layer. The winding process is fully automated, and computer controlled.

The product range spans from 72.5kV up to 420kV.

The wound condenser core is placed in an autoclave to achieve the final drying phase and to be fully impregnated with resin under vacuum. The result is a solid core, mechanically robust and thermally class E (120°C) according to IEC standard. The manufacturing process such as the machining and shaping of the core is automatic and computer-controlled to ensure high quality level.



## Standards

- Bushings conform to IEC-60137
- Bushings conforming to IEEE C57.19.01 electrical values also available

## Key Benefits

- Partial discharge-free up to the rated voltage
- Low  $\tan\delta < 0,4\%$
- Installation in any position
- Long lifetime and high reliability
- Maintenance-free
- High product flexibility
- Excellent mechanical strength
- High thermal strength (class E, 120°C)
- Suitable for Ester oil immersion media



### PCTR Bushings Main Features

- Oil-to-Oil
- Resin Impregnated Paper
- Installation in any position
- Partial discharges < 5pC at 1.5 Um/V3
- Power factor tap grounded through the cap
- Flange made of corrosion-free aluminum
- Execution with draw-lead or bottom connection solid conductor

### Bushing Designation PCTR.145.650.1250

CODE	DESCRIPTION
P	Condenser bushings ('P' from the Italian word 'Passante')
C	Cable
T	Transformer
R	Resin Impregnated Paper (RIP)
145	Rated voltage in kV
650	BIL in kV
1250	Rated current in A

### Nameplate

Each bushing is provided with a nameplate, containing complete electrical data and the serial number, in accordance with the requirements of IEC/IEEE requirements.

The aluminum nameplate is secured to the flange with rivets and carries the following information as in Fig. 2.

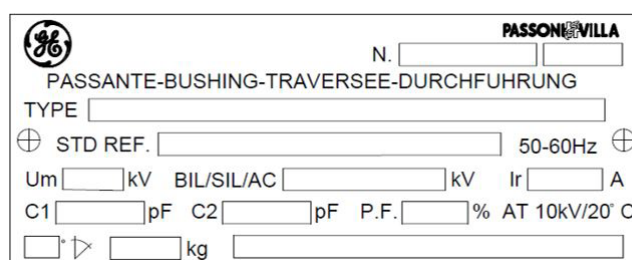
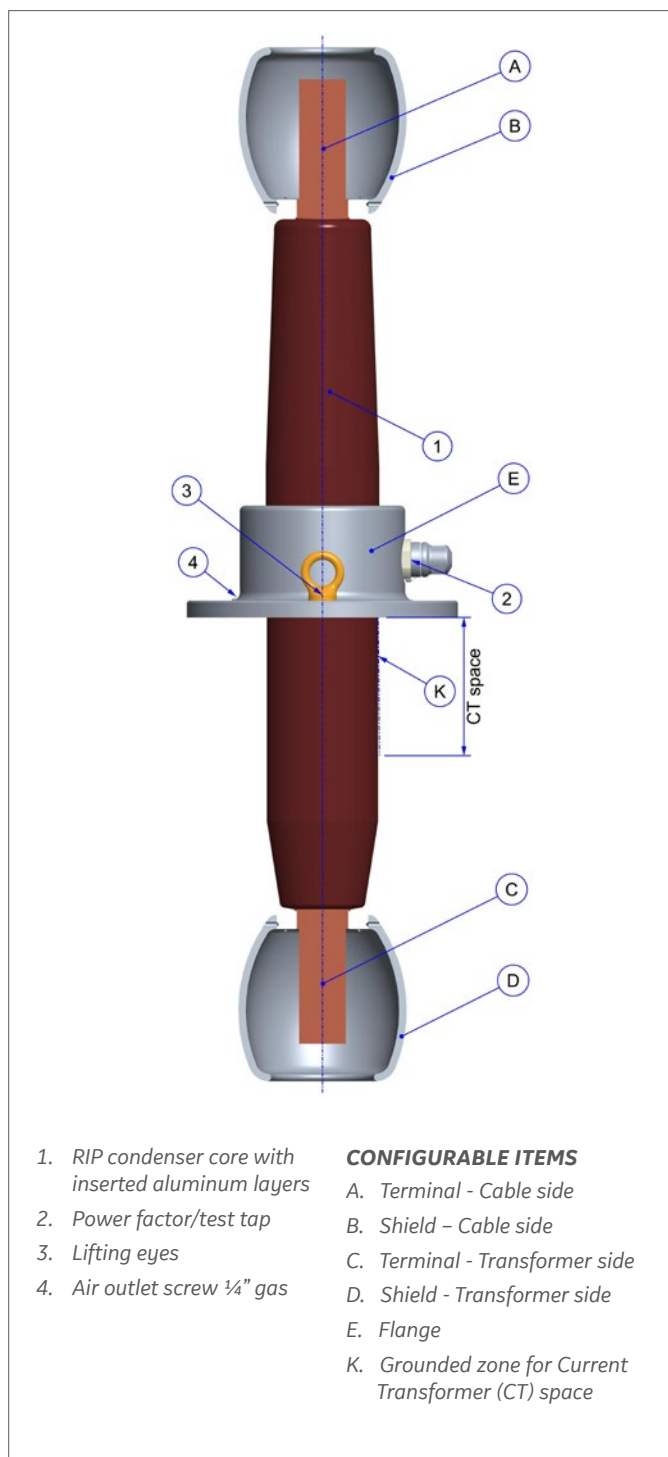

Fig. 2: Nameplate



- |   |   |
|---|---|
| 1. RIP condenser core with inserted aluminum layers | <b>CONFIGURABLE ITEMS</b>                           |
| 2. Power factor/test tap                            | A. Terminal - Cable side                            |
| 3. Lifting eyes                                     | B. Shield - Cable side                              |
| 4. Air outlet screw 1/4" gas                        | C. Terminal - Transformer side                      |
|   | D. Shield - Transformer side                        |
|   | E. Flange   |
|   | K. Grounded zone for Current Transformer (CT) space |

Fig. 1: PCTR typical components

## Connection types and configurations

The bushing can be configured with two connections execution, depending on the current rating and preferred design of the transformer manufacturer.

The bushing platform enables to separate selection of shields and terminals of the both sides (oil and cable).

### Draw Lead (DL)

Draw lead (DL) system (Fig.3) for greater ease of assembly, when the required current capacity is at a relative lower rate. The draw lead is the current path through the bushing. In this case the cable side terminal is made of copper as default (Fig.4) to easily weld the transformer lead to the bushing terminal directly. For the draw lead application, the bottom side shield is provided by default. The shield on the cable side is optional and if requested can be for axial connection only (Fig.5) and for lateral connection (Fig.6) with dedicated lateral hole and 360° orientable possibility.

### Bottom connection (BC)

Bottom connection (BC) (Fig.7) for higher current capability and higher mechanical performance. The current is lead through a central conductor made of aluminum or copper depending on the current rating; the terminals, cable side and oil side, are made of copper or aluminum consequently. The terminals shapes can be round (Fig.8/9) or flag (Fig.10/11) type in cable and in transformer side independently.

Cable and oil side shields (Fig.12) are optional, and the transformer manufacturer can choose to guarantee to right insulation coordination with the insulation barriers. Additionally, the cable side shield can be provided for lateral connection option with dedicated lateral hole (Fig. 13).

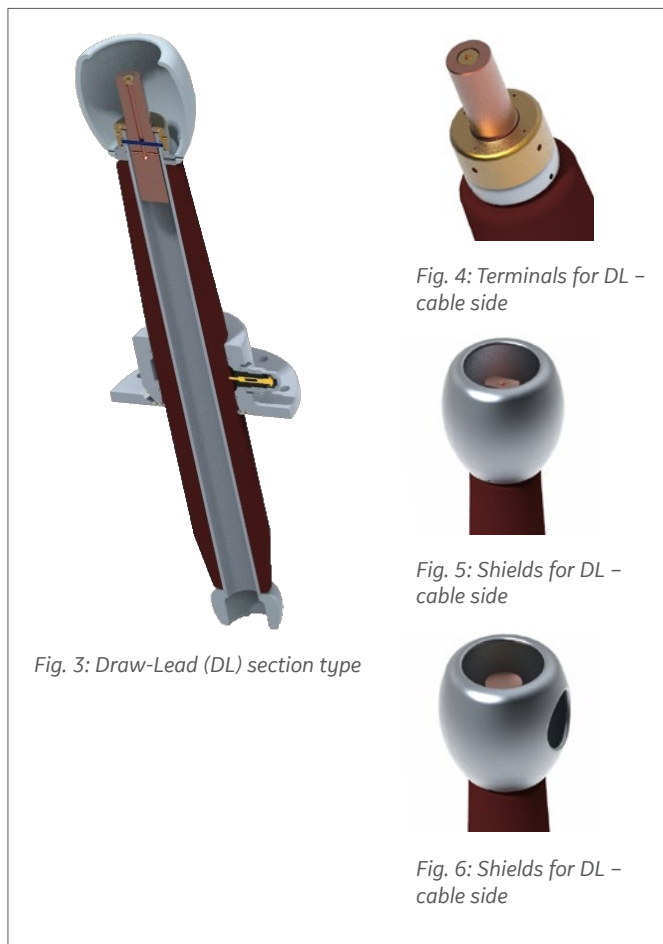

Fig. 3: Draw-Lead (DL) section type

Fig. 4: Terminals for DL – cable side

Fig. 5: Shields for DL – cable side

Fig. 6: Shields for DL – cable side



Fig. 7: Bottom Connection (BC) section type

Fig. 8/9: Round Terminals type for BC – cable side and transformer side

Fig. 10/11: Flag Terminals for BC – cable side and transformer side

Fig. 12/13: Shields for BC – cable side and transformer side

## Components and Accessories

### Flange

The flange is made of aluminum casting and is equipped with the following accessories:

- Power factor/test tap (tested at 2 kV for 60s)
- Air outlet screw (1/4" gas outlet plug)
- Lifting holes

### Metal Surface Treatment

All metal bushing surfaces, made by aluminum alloy, have high resistance in industrial environment with high humidity content and aggressive atmosphere, like offshore with high salinity.

The tapping includes surface treatment to avoid corrosion throughout lifetime and to allow easy assembly and disassembly of its cover for service activities.

Any special finishing or final painting are customer's option.

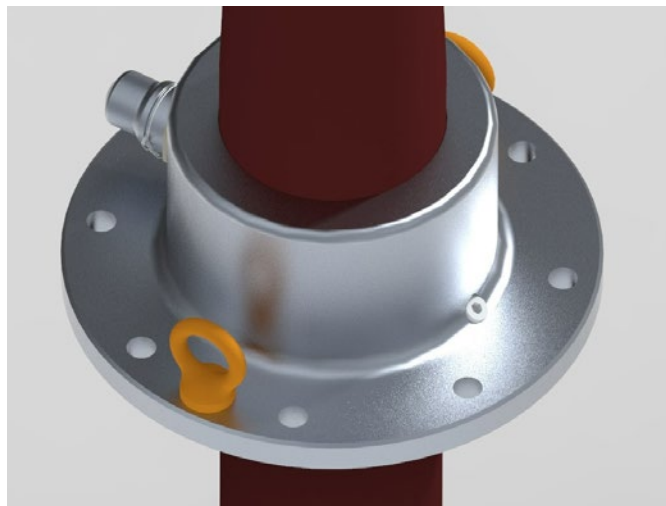

Fig. 14: Flange



Fig. 15/16: Power factor tap

### Power Factor Measuring Tap

The PF tap is the connection to the outer conducting/last layer of a capacitance graded bushing. It is accessible from outside the bushing, insulated from the flange or other fixing device and measures the dissipation factor, capacitance and partial discharge while the bushing flange is earthed. A suitable fully mounted PF measuring tap is supplied with all RIP bushings.

Special PF French type can be provided on request.

### Power Factor Tap Extension

The test tap can be led out as insulated flexible wire and is equipped with a traction relief in the flange. If the bushing is dispatched, this flexible wire is screwed to the flange with a cable lug which is grounded.

Note 1: the cable is led outside of the transformer and fixed on a standard test tap.

Note 2: this device is an accessory and not part of the standard delivery.

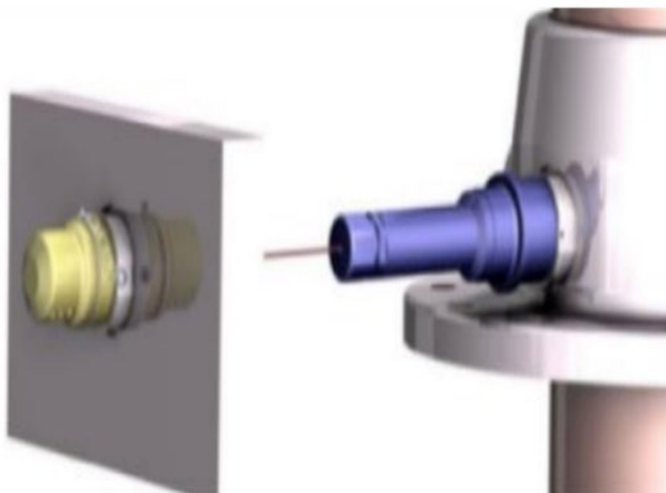

Fig 17: Mounting of remote PF tap with cable



Fig.18: Remote PF tap with cable

## Components and Accessories

### Tests

All bushings have electrical characteristics and are tested in compliance with the latest edition of IEC 60137 Standards.

Insulated bushing for alternating voltages above 1000 V and main National Standards.

### Type Tests

Measurement of dielectric dissipation factor (tan delta), capacitance and partial discharge quantity before and after the series of type tests:

- Tests of tap insulation
- Power-frequency voltage withstand test
- Lightning impulse voltage withstand test (BIL)
- Switching impulse voltage withstand test (SIL) for bushings rating 245kV and above
- Thermal stability test for bushings with  $U_m$  greater than 300 kV
- Temperature rise test
- Verification of thermal short-time current withstand
- Cantilever load withstand test
- Tightness test
- Verification of dimensions

### Routine Tests

- Tests of tap insulation
- Dielectric dissipation factor (tan delta), capacitance and partial discharge quantity measurement
- Lightning impulse voltage withstand test (BIL), when prescribed
- Power-frequency voltage withstand test
- Measurement of partial discharge quantity
- Test of tap insulation
- Tightness test
- Visual inspection and dimensional check

### Packing & Transportation

After tests and before packing, the bushing is cleaned of any oil or dust. PCTR bushings are normally shipped in the horizontal position in cases of three (for voltages up to 170 kV). Terminals and exposed parts are wrapped in polyethylene bags to apply an additional protection from ambient contamination such as dust and moisture and any transport damage.

### Long Term Storage Accessories

For long term storage and upon request the bushings are equipped with protective tank filled with nitrogen to protect the condenser core against any damage, moisture absorbing and humidity.



Fig. 19.1: Bushing under test



Fig. 19.2: Packaging and protective tank

PCTR Range from 72.5kV to 420kV: Ratings/Dimensions

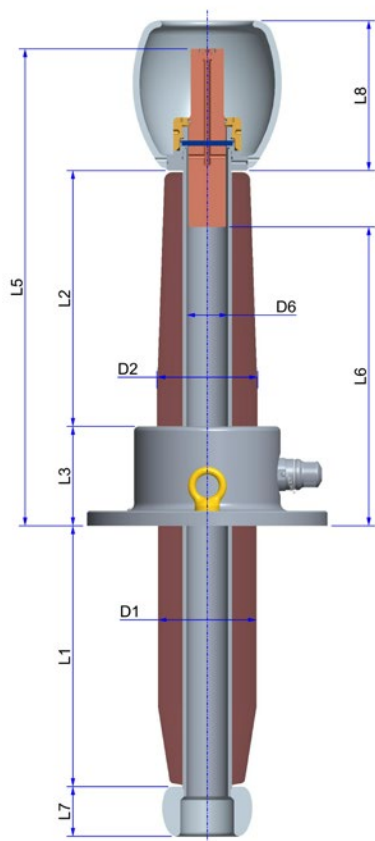

Fig.20: PCTR Draw-Lead (DL) type

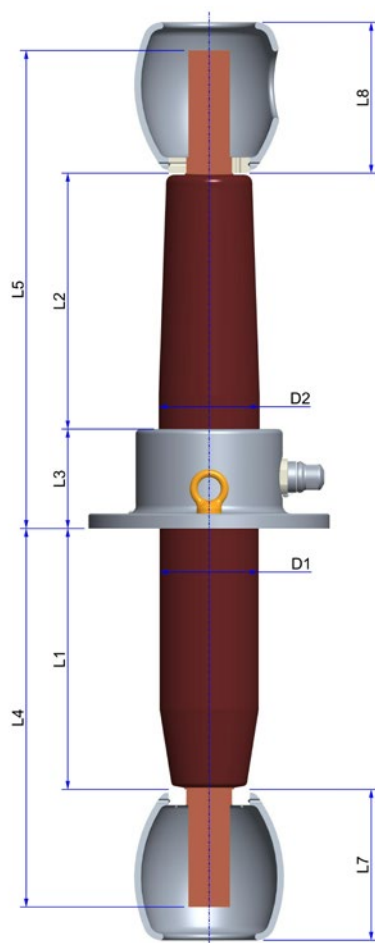

Fig.21: PCTR Bottom Connection (BC) type

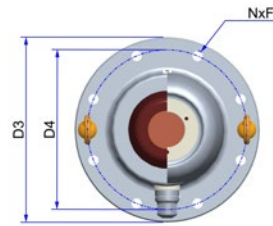

Fig.22: Flange

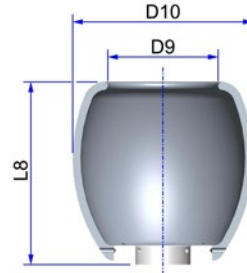

Fig.23: Shield cable side without lateral hole

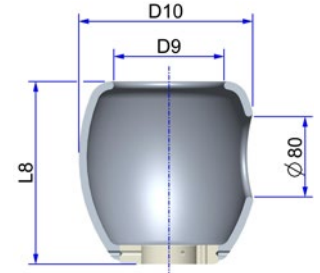

Fig.24: Shield cable side with lateral hole

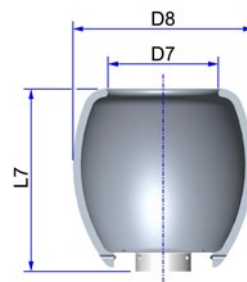

Fig.25: Shield trafo side

Terminal for DL type

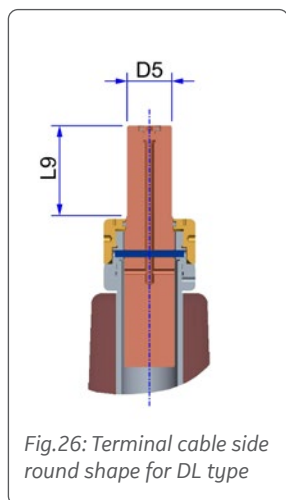

Fig.26: Terminal cable side round shape for DL type

Terminals for BC type in cable or transformer side

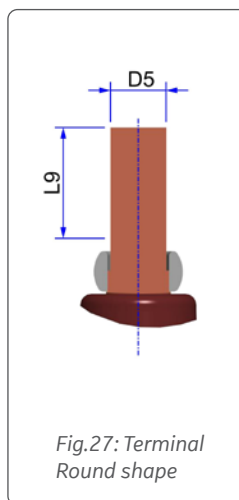

Fig.27: Terminal Round shape

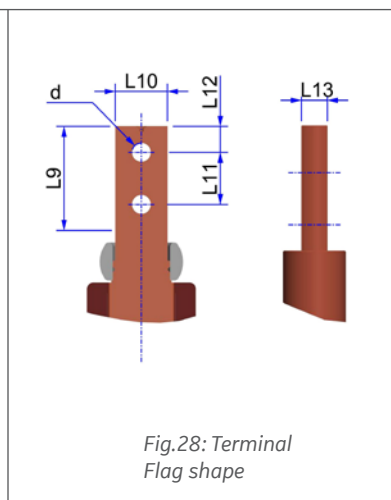

Fig.28: Terminal Flag shape

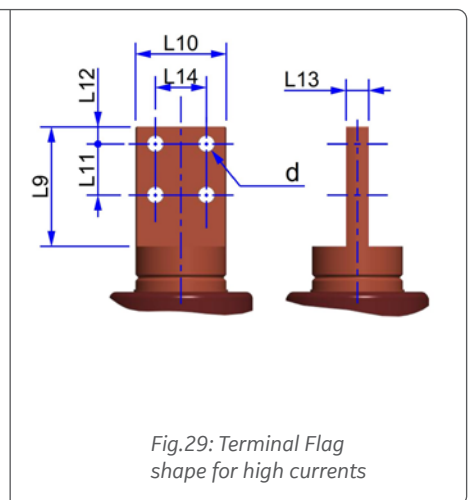

Fig.29: Terminal Flag shape for high currents

PCTR Bushings 72.5kV to 420kV

Condenser bushing oil-oil for Transformers	Nominal System Voltage	Rated line to earth Voltage	Dry lightning Impulse (BIL)	Rated continuous current	Power frequency withstand voltage (for 60 s) Dry	Draw Lead connection (DL)	Bottom connection (BC)	Cantilever withstand load	Short time rating for 2s (As per IEC 60137)	Short time rating for 1s / 3s	L1	L2	L3	L4	L5	L6
											(K can be 0, 100, 300, 500 or 600)	mm	mm	mm	mm	mm
TYPE/Voltage[kV]/ Current Range [A]	kV	kV	kVp	A	kV		N	kA	kA	mm	mm	mm	mm	mm	mm	mm
72.5.325	1250	72.5	42	325	1250	155	x	1250	31	44/26	177 + K	177	120	-	445	229
	1600				x		40	57/33	-							
	2000				x		3150	50	71/41	320 + K	-					
	2500				x		63	88/51	-							
	3150				x		4000	79	111/64	342 + K	-					
123.550	1250	123	71	550	1250	255	x	3150	31	44/26	310 + K	310	120	-	578	362
	1600				x		40	57/33	-							
	2000				x		4000	50	71/41	452 + K	-					
	2500				x		63	88/51	-							
	3150				x		4000	79	111/64	503 + K	630			-		
145.650	1000	145	84	650	1000	305	x	3150	25	35/20	360 + K	360	120	-	630	412
	1250				x		31	44/26	-							
	1600				x		4000	40	57/33	503 + K	-					
	2000				x		50	71/41	-							
	2500				x		4000	63	88/51	-						
	3150				x		4000	79	111/64	503 + K	-					
170.750	1250	170	98	750	1250	355	x	4000	31	44/26	410 + K	410	120	-	678	462
	1600				x		40	57/33	-							
	2000				x		5000	50	71/41	552 + K	-					
	2500				x		63	88/51	-							
	3150				x		5000	79	111/64	552 + K	-					
245.1050	1250	245	142	1050	1250	505	x	4000	31	44/26	580 + K*	580	120	-	850	540
	1600				x		40	57/33	-							
	2000				x		5000	50	71/41	723 + K				-		
	2500				x		63	88/51	-							
	3150*				x		5000	79	111/64	723 + K*				-		
420.1550	1250	450	242	1550	1250	750	x	4000	31	44/26	815 + K*	815	180	980 + K*	1160	-
	1600				x		40	57/33	-							
	2000				x		5000	50	71/41	-						
	2500				x		63	88/51	-							

NOTES:

\*PCTR 245.1050.3150 type available only for K>100

K is the CT space length in the transformer side (standard dimensions are 0, 100, 300, 500 and 600mm)

For ratings or dimensions not listed, please contact us.

PCTR Bushings 72.5kV to 420kV

Condenser bushing oil-oil for Transformers	D1	D2	D3	D4	NxF	L7	D7	D8	L8	D9	D10	Shield - CABLE SIDE (B)	Shield - TRAF0 SIDE (D)	
	mm	mm	mm	mm	n°x mm	mm	mm	mm	mm	mm	mm			
TYPE/Voltage[kV]/ Current Range [A]														
72.5.325	1250					60	65	109	182	110	180	Fig.23/24	Fig.25	
	1600	87	90	225	185	6x16	188	100	140	182	110	180	Fig.23/24	Fig.25
	2000													
	2500													
	3150	119	122	290	250	6X16	182	110	180	182	110	180	Fig.23	Fig.25
123.550	1250					60	65	109	182	110	180	Fig.23/24	Fig.25	
	1600	119	122	290	250	6x16	182	110	180	182	110	180	Fig.23/24	Fig.25
	2000													
	2500													
	3150	159	162	335	290	12x16	182	110	180	182	110	180	Fig.23	Fig.25
145.650	1000					60	65	109	182	110	180	Fig.23/24	Fig.25	
	1250	119	122	290	250	6x16	182	110	180	182	110	180	Fig.23/24	Fig.25
	1600													
	2000													
	2500													
	3150	159	162	335	290	12x16	182	110	180	182	110	180	Fig.23	Fig.25
170.750	1250					91	75	150	182	110	180	Fig.23/24	Fig.25	
	1600	159	162	335	290	12x16	182	110	180	182	110	180	Fig.23/24	Fig.25
	2000													
	2500													
	3150	203	203	450	400	12x16	182	110	180	182	110	180	Fig.23	Fig.25
245.1050	1250	203	203	450	400	12x16	182	110	180	182	110	180	Fig.23/24	Fig.25
	1600													
	2000	159	162	335	290	12x16	182	110	180	182	110	180	Fig.23/24	Fig.25
	2500													
	3150*	203	203	450	400	12x16	182	110	180	182	110	180	Fig.23	Fig.25
420.1550	1250	285	285	500	450	12x23	225	166	291	225	166	291	Fig.23	Fig.25
	1600													
	2000	285	285	500	450	12x23	225	166	291	225	166	291	Fig.23	Fig.25
	2500													

**NOTES:**

\*PCTR 245.1050.3150 type available only for K>100

K is the CT space length in the transformer side (standard dimensions are 0, 100, 300, 500 and 600mm)

For ratings or dimensions not listed, please contact us.



## PCTR Bushings 72.5kV to 420kV

Condenser bushing oil-oil for Transformers	Terminal - CABLE SIDE (A)	Terminal - TRAF0 SIDE (C)	D5	L9	L10	n x d	L11	L12	L13	L14
			mm	mm	mm	mm	mm	mm	mm	mm
72.5.325	1250	Fig.26	-	35	80	-	-	-	-	-
	1600	Fig.27/28	Fig.27/28	40	80	35	2 x 14	40	20	20
	2000									
	2500	Fig.29	Fig.29	-	100	70	4 x 14	40	20	20
123.550	1250	Fig.26	-	40	80	-	-	-	-	-
	1600	Fig.27/28	Fig.27/28	50	100	45	2 x 14	40	20	20
	2000									
	2500	Fig.29	Fig.29	-	105	75	4 x 14	45	15	20
145.650	1000	Fig.26	-	35	80	-	-	-	-	-
	1250	Fig.27/28	Fig.27/28	40	80	40	2 x 14	40	20	20
	1600									
	2000	Fig.29	Fig.29	-	105	75	4 x 14	45	15	20
170.750	1250	Fig.26	-	40	80	-	-	-	-	-
	1600	Fig.27/28	Fig.27/28	50	100	57	2 x 14	40	20	20
	2000									
	2500	Fig.29	Fig.29	-	105	80	4 x 14	45	15	45
245.1050	1250	Fig.26	-	40	80	-	-	-	-	-
	1600	Fig.27/28	Fig.27/28	40	100	40	2 x 14	40	20	20
	2000									
	2500	Fig.29	Fig.29	-	105	80	4 x 14	45	15	20
3150*										
420.1550	1250	Fig.27/28	Fig.27/28	50	80	80	2 x 18	40	20	20
	1600									
	2000	Fig.27/28	Fig.27/28	50	80	80	2 x 18	40	20	20
	2500									

**NOTES:**

\*PCTR 245.1050.3150 type available only for K>100

K is the CT space length in the transformer side (standard dimensions are 0, 100, 300, 500 and 600mm)

For ratings or dimensions not listed, please contact us.

## Bushing Selection Example

### Electrical Data

First selection can be done according the electrical data required, then:

- Rated voltage.
- Rated current.
- The other system voltages for the dielectric coordination are driven by IEC 60137, cantilever value included.

This selection can identify if the bushing can be Draw-Lead (DL) or Bottom-Connection (BC) type.

### Mechanical Data

- A. Terminal – cable side among different types A1, A2...etc.
- B. Shield – cable side among different types B1, B2...etc.
- C. Shield – trafo side among different types C1, C2...etc.
- D. Terminal – trafo side among different types D1, D2...etc
- E. Flange among different types E1, E2...etc
- K. CT space (under flange millimeters required for the current transformer installation in the transformer side
- T. Min. ambient temperature of the place where the bushing/ transformer will be installed.

Rated Voltage (kV)		Rated Current (A)	CT space (mm) K choice	TERMINAL - cable side A choice	SHIELD - cable side B choice	SHIELD - trafo side C choice	TERMINAL - trafo side D choice	Min. ambient air temperature (°C)	Main FLANGE type E choice
145	x	1250	0	A1	B1 = no shield	C1 = no shield	D1	T1 = -25°C	E1
		1600	100	A2	B2	C2	D2	T2 = -40°C	E2
		2000	300		B3				
			500						
			600						

1	2	3	4	5	6																																																																																																														
TERMINAL-cable side types	SHIELD-cable side types	SHIELD-trafo side types	TERMINAL-trafo side types	Main FLANGE types																																																																																																															
<b>A1</b> terminal round type AI for 1250A/1600A Cu for 2000A 	B1 = no shield 	C1 = no shield 	D1 terminal round type AI for 1250A/1600A Cu for 2000A 	<b>E1</b> flange type 																																																																																																															
<b>A2</b> terminal flag type AI for 1250A/1600A Cu for 2000A 	B2 shield for axial connection 	<b>C2</b> shield 	<b>D2</b> terminal flag type AI for 1250A/1600A Cu for 2000A 	<b>E2</b> flange type 																																																																																																															
	<b>B3</b> orientable shield for lateral connection 	<table border="1"> <thead> <tr> <th colspan="10">BUSHING CONFIGURATION SELECTION</th> </tr> <tr> <th>Rated Voltage (kV)</th> <th>Rated Current (A)</th> <th>CT space (mm) K choice</th> <th>TERMINAL - cable side A choice</th> <th>SHIELD - cable side B choice</th> <th>SHIELD - trafo side C choice</th> <th>TERMINAL - trafo side D choice</th> <th>Min. ambient air temperature (°C)</th> <th>Main FLANGE type E choice</th> </tr> </thead> <tbody> <tr> <td>145</td> <td>x</td> <td>1250</td> <td>0</td> <td>A1</td> <td>B1 = no shield</td> <td>C1 = no shield</td> <td>D1</td> <td>E1</td> </tr> <tr> <td></td> <td></td> <td>1600</td> <td>100</td> <td>A2</td> <td>B2</td> <td>C2</td> <td>D2</td> <td>E2</td> </tr> <tr> <td></td> <td></td> <td>2000</td> <td>300</td> <td></td> <td>B3</td> <td></td> <td></td> <td></td> </tr> <tr> <td></td> <td></td> <td>500</td> <td></td> <td></td> <td></td> <td></td> <td></td> <td></td> </tr> <tr> <td></td> <td></td> <td>600</td> <td></td> <td></td> <td></td> <td></td> <td></td> <td></td> </tr> </tbody> </table>				BUSHING CONFIGURATION SELECTION										Rated Voltage (kV)	Rated Current (A)	CT space (mm) K choice	TERMINAL - cable side A choice	SHIELD - cable side B choice	SHIELD - trafo side C choice	TERMINAL - trafo side D choice	Min. ambient air temperature (°C)	Main FLANGE type E choice	145	x	1250	0	A1	B1 = no shield	C1 = no shield	D1	E1			1600	100	A2	B2	C2	D2	E2			2000	300		B3						500									600																																																				
BUSHING CONFIGURATION SELECTION																																																																																																																			
Rated Voltage (kV)	Rated Current (A)	CT space (mm) K choice	TERMINAL - cable side A choice	SHIELD - cable side B choice	SHIELD - trafo side C choice	TERMINAL - trafo side D choice	Min. ambient air temperature (°C)	Main FLANGE type E choice																																																																																																											
145	x	1250	0	A1	B1 = no shield	C1 = no shield	D1	E1																																																																																																											
		1600	100	A2	B2	C2	D2	E2																																																																																																											
		2000	300		B3																																																																																																														
		500																																																																																																																	
		600																																																																																																																	
<table border="1"> <thead> <tr> <th colspan="2">Bushing Data</th> <th>IEC 60137</th> <th>IEEE C57.19.01</th> <th>Minimum arcing distance</th> <th>360 mm</th> <th>Positions on drawing</th> <th>R00E1450</th> <th>0-600</th> <th>1133-1804</th> <th>37-50</th> <th>CABLE and TRAFD sides with ALUMINIUM or COPPER TERMINALS</th> </tr> </thead> <tbody> <tr> <td>Rated voltage (50/60 Hz)</td> <td>145 kV</td> <td>138 kV</td> <td>138 kV</td> <td>Minimum creepage distance</td> <td>--- mm</td> <td>1 Cable side terminal</td> <td>Part Number</td> <td>Variant Number</td> <td>K (mm)</td> <td>L.Tot. (mm)</td> <td>Weight (kg)</td> <td>Notes</td> </tr> <tr> <td>Rated phase-to-earth voltage</td> <td>84 kV</td> <td>102 kV</td> <td>102 kV</td> <td>Cantilever test load 1 min.</td> <td>4000 N</td> <td>2 Flange (AD)</td> <td colspan="2"> <b>PASSONVILLA</b> </td> <td colspan="3">                     Configuration Bushing Type: PCTR145.650...00 K=... A-B-C-D-T-E                 </td> </tr> <tr> <td>Rated power-frequency voltage</td> <td>305 kV</td> <td>310 kV</td> <td>310 kV</td> <td>Maximum angle of mounting from the vertical</td> <td>90°</td> <td>3 Air outlet screw</td> <td>Scale: 13/100</td> <td>Design Authority: RPV</td> <td>Units: mm</td> <td>Local Unit: RPV</td> <td>Format: A3</td> <td>Product Code: PCTR</td> </tr> <tr> <td>Dry lightning impulse voltage</td> <td>650 kV</td> <td>650 kV</td> <td>650 kV</td> <td>Maximum operating altitude</td> <td>1000 m</td> <td>4 Trafo side connection</td> <td colspan="2">                     Description: OIL-OIL BUSHING OUTLINE                 </td> <td colspan="3">                     Created: 20/04/2022 Luca PEREGO                 </td> </tr> <tr> <td></td> <td></td> <td></td> <td></td> <td>Capacitor technology: resin impregnated paper</td> <td></td> <td>5 Power factor tap</td> <td colspan="2">                     Grid Solutions                 </td> <td colspan="3">                     EC number: _____ Sheet: 1/1                 </td> </tr> <tr> <td></td> <td></td> <td></td> <td></td> <td>Conductor execution: BOTTOM CONNECTION</td> <td></td> <td>6 Lifting eyes</td> <td colspan="2">                     PCTR 145 kV 1250A/1600A/2000A                 </td> <td colspan="3">                     Drawing number: RXF00736-00 Rev. B                 </td> </tr> <tr> <td></td> <td></td> <td></td> <td></td> <td></td> <td></td> <td>7 Shield cable side</td> <td colspan="2"></td> <td colspan="3"></td> </tr> <tr> <td></td> <td></td> <td></td> <td></td> <td></td> <td></td> <td>8 Shield trafo side</td> <td colspan="2"></td> <td colspan="3"></td> </tr> </tbody> </table>						Bushing Data		IEC 60137	IEEE C57.19.01	Minimum arcing distance	360 mm	Positions on drawing	R00E1450	0-600	1133-1804	37-50	CABLE and TRAFD sides with ALUMINIUM or COPPER TERMINALS	Rated voltage (50/60 Hz)	145 kV	138 kV	138 kV	Minimum creepage distance	--- mm	1 Cable side terminal	Part Number	Variant Number	K (mm)	L.Tot. (mm)	Weight (kg)	Notes	Rated phase-to-earth voltage	84 kV	102 kV	102 kV	Cantilever test load 1 min.	4000 N	2 Flange (AD)	<b>PASSONVILLA</b>		Configuration Bushing Type: PCTR145.650...00 K=... A-B-C-D-T-E			Rated power-frequency voltage	305 kV	310 kV	310 kV	Maximum angle of mounting from the vertical	90°	3 Air outlet screw	Scale: 13/100	Design Authority: RPV	Units: mm	Local Unit: RPV	Format: A3	Product Code: PCTR	Dry lightning impulse voltage	650 kV	650 kV	650 kV	Maximum operating altitude	1000 m	4 Trafo side connection	Description: OIL-OIL BUSHING OUTLINE		Created: 20/04/2022 Luca PEREGO							Capacitor technology: resin impregnated paper		5 Power factor tap	Grid Solutions		EC number: _____ Sheet: 1/1							Conductor execution: BOTTOM CONNECTION		6 Lifting eyes	PCTR 145 kV 1250A/1600A/2000A		Drawing number: RXF00736-00 Rev. B									7 Shield cable side												8 Shield trafo side					
Bushing Data		IEC 60137	IEEE C57.19.01	Minimum arcing distance	360 mm	Positions on drawing	R00E1450	0-600	1133-1804	37-50	CABLE and TRAFD sides with ALUMINIUM or COPPER TERMINALS																																																																																																								
Rated voltage (50/60 Hz)	145 kV	138 kV	138 kV	Minimum creepage distance	--- mm	1 Cable side terminal	Part Number	Variant Number	K (mm)	L.Tot. (mm)	Weight (kg)	Notes																																																																																																							
Rated phase-to-earth voltage	84 kV	102 kV	102 kV	Cantilever test load 1 min.	4000 N	2 Flange (AD)	<b>PASSONVILLA</b>		Configuration Bushing Type: PCTR145.650...00 K=... A-B-C-D-T-E																																																																																																										
Rated power-frequency voltage	305 kV	310 kV	310 kV	Maximum angle of mounting from the vertical	90°	3 Air outlet screw	Scale: 13/100	Design Authority: RPV	Units: mm	Local Unit: RPV	Format: A3	Product Code: PCTR																																																																																																							
Dry lightning impulse voltage	650 kV	650 kV	650 kV	Maximum operating altitude	1000 m	4 Trafo side connection	Description: OIL-OIL BUSHING OUTLINE		Created: 20/04/2022 Luca PEREGO																																																																																																										
				Capacitor technology: resin impregnated paper		5 Power factor tap	Grid Solutions		EC number: _____ Sheet: 1/1																																																																																																										
				Conductor execution: BOTTOM CONNECTION		6 Lifting eyes	PCTR 145 kV 1250A/1600A/2000A		Drawing number: RXF00736-00 Rev. B																																																																																																										
						7 Shield cable side																																																																																																													
						8 Shield trafo side																																																																																																													

Fig.30: Detailed drawing example for bushing selection

## Bushing Selection Example

Fig. 30 shows as example how the bushing was selected in particular:

- PCTR 145kV 1600A (BIL 650kV)
- K = 300mm (the length of the CT space)
- A1 - terminal – cable side that is round type 80x40 made of aluminum because for 1600A.
- B3 - shield – cable side that is for lateral connection.
- C2 - shield - trafo side.
- D2 terminal – trafo side that is a flag type made of aluminum because for 1600A.
- T2 min. ambient temperature = -40° where the substation is placed.
- E1 flange with the dimension indicated in the selected detail in Fig. 30.

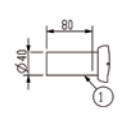
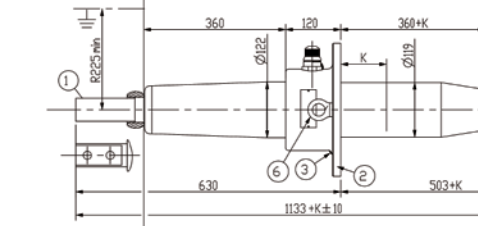
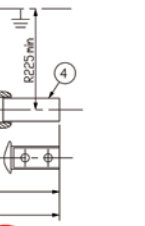
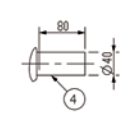
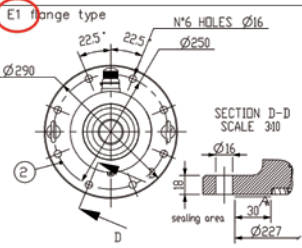
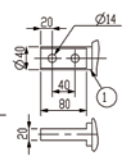
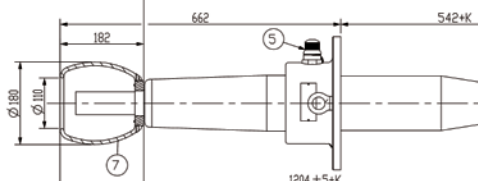
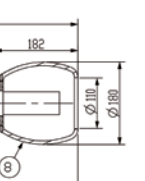
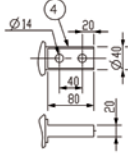
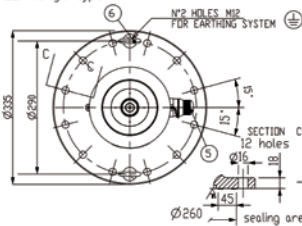
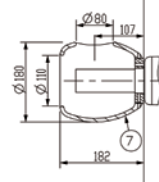
Then the Configuration Bushing Type is:

PCTR.145.650.1600 K=300 A1.B3.C2.D2.T2.E1



Fig.31: Configured bushing



*Bushings Manufacturing Site :*

*GE Grid Solutions Sesto San Giovanni,  
Sesto San Giovanni  
Milan, Italy*

[GEGridSolutions.com](https://www.GEGridSolutions.com)

IEC is a registered trademark of Commission Electrotechnique Internationale. IEEE is a registered trademark of the Institute of Electrical Electronics Engineers, Inc.

GE and the GE monogram are trademarks of General Electric Company. GE reserves the right to make changes to specifications of products described at any time without notice and without obligation to notify any person of such changes.

Copyright 2021, General Electric Company. All Rights Reserved.

GEA-33233-(E)  
English  
220505

