

MiCOM Agile P741, P742, P743

Distributed Busbar Protection with High-Availability Communications

The MiCOM P741, P742, P743 Agile numerical busbar protection is now available with redundant fiber-optic communications. The scheme offers the highest availability, with the automatic ability to ride through fiber disconnections without the need for maintenance attention.

Power system busbars are a key node in the delivery of energy to consumers. It is therefore essential to provide fast and discriminative protection which will initiate precise isolation of any faulted bus section in the event of an internal fault, to avoid any disruption in supplies to non-faulted bus sections and circuits.

In a distributed busbar protection scheme, the fiber optic links between the feeder bays and the central unit (CU) are essential for correct operation. Most schemes offer a single point-to-point link from each bay to the CU. Should any of those links be compromised, the CU will be missing the current measurements for that bay – meaning that a zone of protection is disabled. The dispatcher has the tough choice whether (1) to open the circuit breaker for the bay with compromised communications to restore the differential protection to service, or (2) to continue to run on slower back-up protection alone.

The latest release of GE's P741, P742, P743 busbar protection offers the possibility to duplicate the fiber optic communications between the bays and the central unit. This redundancy feature permits ride-through for fiber breaks, joint/splice failures, transmitter failures or accidental disconnections.

The redundancy in communications between the central unit and the bay peripheral units allows the existence of two communication paths in parallel, one being active and the other connected as standby. A choice of different switching options is available, depending on the utility's preferred topology for the busbar scheme. This switching is performed automatically, upon detection of a failure in the primary path.

Topology Options

A number of topology options exist to implement the redundancy scheme. See on the back page of this document.



Key Benefits

- Fast redundant communications
- Automatic self-healing on fiber disconnection
- Adaptable to any busbar configuration
- Extends for schemes up to 28 bays
- Optimized security and dependability, with subcycle performance
- Identical relaying hardware cost as per single fiber schemes



Option 1: Fiber Optic Redundancy

This topology caters for instances of breakage/disconnection of fiber optics. A fiber-optic switch is installed in the relay room, as close to the busbar central unit (CU) as possible. In a distributed scheme, there may be many tens, or even hundreds of meters of fiber runs, with each link and splice being a potential point of failure (however small this probability may be). Figure 1 shows that when the primary link RX1 or TX1 is faulty, the CU detects a fiber optic communications error and sends a command to the switch in order to switch to the standby communications (RX2-TX2) in all connected bay peripheral units (PUs).

Advantages

- Switching time is less than 4s
- Channel 2 integrity can be supervised when channel 1 is in service using an advanced switch

Disadvantage

- No redundancy for the small portion of the network between the CU and the switch
- Requires purchase of a 3rd party optical switch

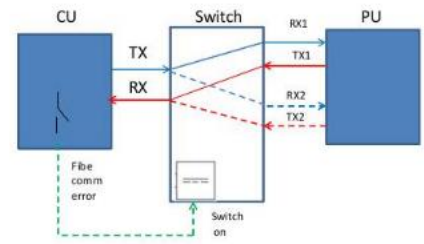

Figure 1 – Option 1 with switch (one PU only shown, for simplicity)

Option 2: Fibre Optic and Central Unit Redundancy

In this topology, as well as catering for fiber optic redundancy, the scheme considers that the central unit is in itself a real-world device, which although highly-reliable, might in a rare case experience a failure. For the highest scheme availability, both the fibers and the CUs are duplicated. Figure 2 shows that a signal output from CU1 is sent to switch off the supply to the spare CU (CU2) when channel 1 is healthy in all the PUs. This command will block all transmissions in the standby channel 2 (RX2 and TX2).

Advantages

- 100% redundancy for communication channels, including final connection(s) to CU
- Likely to be a cheaper solution, Grid Solutions is the one-stop-shop for all scheme devices

Disadvantages

- Switching time marginally longer at around 20s, but negligible effect on downtime
- Second fiber channel not continuously supervised, requires a maintenance enforced switchover to test

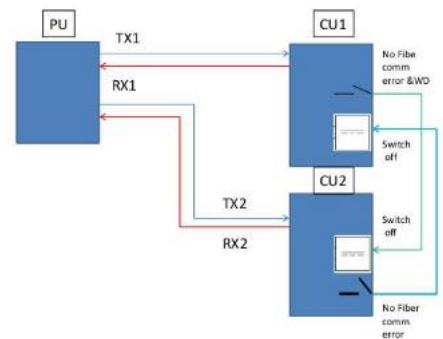

Figure 2 – Option 2 without switch

Option 3: Full Redundancy with Supervision of all Channels

An extension of option 2 is available in instances where both communication channels are required to be continuously supervised. Figure 3 shows that a signal output from CU1 is sent to switch on the supply to fiber switch 2 if channel 1 fails in any way. This will enable all transmissions in the standby channel 2. The same will be true, vice versa, should CU2 communications experience a failure.

Advantage

- Switching time is less than 4s
- Both channels can be continuously supervised, including the channel in standby mode

Disadvantage

- Most expensive option, requiring smart fiber switches with inbuilt monitoring features

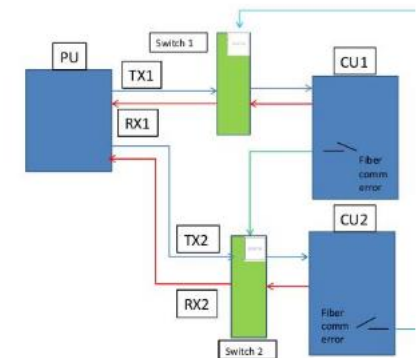

Figure 3 – Option 3 switches with two central units

For more information please contact
Grid Solutions
GE Renewable Energy

Worldwide Contact Center

Web: www.GEGridSolutions.com/contact
Phone: +44 (0) 1785 250 070

GEGridSolutions.com

IEC is a registered trademark of Commission Electrotechnique Internationale. IEEE is a registered trademark of the Institute of Electrical Electronics Engineers, Inc.

GE and the GE monogram are trademarks of General Electric Company.

GE reserves the right to make changes to specifications of products described at any time without notice and without obligation to notify any person of such changes.

P741_2_3-Brochure-EN-2021-07-Grid-GA-1002. © Copyright 2021, General Electric Company.

