

MiCOM Agile P740



Numerical Busbar Protection

The MiCOM Agile P740 numerical busbar protection scheme provides complete protection for all voltage levels - up to extra / ultra high voltage - and for all busbar configurations.

A Unique Combination of Security, Speed and Sensitivity

GE provides innovative techniques, including Current Transformer supervision, saturation detection and dynamic topology processing algorithms to offer a unique combination of security, speed and sensitivity.

The substation replica processing algorithms ensure that the P740 adapts to the dynamically changing topology of the busbar, which can be displayed on any PC using the substation real time dynamic monitoring tool.

The MiCOM Agile P740 busbar differential protection scheme can be engineered to provide a centralized or distributed architecture. It also supports easy maintenance, operations and future expansion of the busbar. The optional redundant Ethernet board reduces the cost of ownership since the relay is natively embedded in the switchboard. This reduces the amount of standalone switches needed, reducing wiring, power supply and maintenance costs. Furthermore, increasing the availability rate decreases the risk of electrical outages.

Customer Benefits

- Universal scheme for all bus configurations, scalable up to 28 feeders and 8 zones
- Consistent sub-cycle tripping time (13 ms typical)
- CT saturation detection in under 2 ms keeps CT requirements economical
- Multiple independent criteria ensure optimum trip security and selectivity
- Additional earth-fault differential for increased ground fault sensitivity
- High availability with redundant communications between the peripheral units and central unit
- Simple to reconfigure when bays are undergoing maintenance
- IEEE 1588 Precision Time Protocol - efficient time synchronizing direct from the substation LAN
- Cybersecurity aligned to industry standards and services (NERC® CIP, AAA, RADIUS, RBAC, Syslog)

Key Benefits

- Fast fault trip
- Adaptable to any busbar configuration
- IEC 61850-8.1 Ed. 1 / Ed. 2 and IEC 60870-5-103 compliant
- IEC 61850-9-2 LE process bus ready (P743 peripheral unit only)
- Operates with different types of CT (eg. TPS, TPX, TPV, Class X, IEEE C-Class)
- Fast communications
- No insulation problems, thanks to cross-substation current communication via fibre optics

Application Flexibility

- Simple to configure, set, and commission
- Programmable Scheme Logic (PSL) allows easy customization of the protection & control functions
- Digital inputs - deliver ESI 48-4 EB2 noise immunity and are suitable for H7 trip circuit supervision
- Enhanced hardware monitoring with measured and calculated neutral current cross-check
- Harsh environmental coating as standard
- Optional redundancy including IEC 62439 PRP, HSR and RSTP
- Software switchable between IEC 61850 Ed. 1 / Ed. 2



Application

The MiCOM Agile P740 numerical busbar protection scheme is designed to protect a wide range of busbar configurations.

The modular scheme utilises three relay types:

- Central Unit (CU) - P741
- Peripheral Units (PU) - P742 / P743

These units interconnect using fibre optic cables and together with the topology configurator software allow application to all types of busbar configuration. The Central Unit co-ordinates the scheme, receiving signals from all the peripheral units associated with the protected busbars and acts on these signals. The CU then initiates a bus zone protection trip when necessary.

A single central unit can accommodate up to:

- 8 zones
- 28 peripheral units

One PU is associated with each CT location: usually one per incomer/feeder and one or two for each bus coupler/bus section, depending on the number of CTs.

The PUs acquire the analogue signals from the associated CT and the binary signals from the auxiliary contacts of the circuit-breakers and isolators.

The PUs also incorporate the main circuit-breaker failure logic together with additional protection functions (dead zone, overcurrent, etc.).

Where single pole breakers and transfer busbars are employed, the I/O requirements are high in comparison to those required for a single busbar application, so a P743 may be more suitable.

The P743 allows for increased opto inputs, function keys and an optional Ethernet board, and is particularly useful in double busbar applications.

Functions Overview

ANSI	IEC 61850	Features	P741	P742	P743
87BB / P	PhsPDIF	Phase segregated biased current differential, high speed busbar protection	•	-	-
87CZ / P	CzPPDIF	Check zone segregated biased phase current differential, high speed busbar protection	•	-	-
87BB / N	NeuPDIF	Sensitive earth fault bias current controlled busbar protection	•	-	-
87CZ / N	CzNPDIF	Check zone segregated biased earth current differential, high speed busbar protection	•	-	-
50 / 51 / P	OcpPTOC	Phase overcurrent protection (2 stages)	-	•	•
50 / 51 / N	EfmPTOC	Earth overcurrent protection (2 stages)	-	•	•
50ST / P	DzpPhsPTOC	Dead zone earth protection (short zone between CTs and open CBs)	-	•	•
50ST / N	DzpEfmPTOC	Dead zone earth protection (short zone between CTs and open CBs)	-	•	•
27/59 EXT		Voltage supervision criteria (external detection)	•	•	•
CTS		Current transformer supervision	•	•	•
50BF	RBRF	Breaker failure protection (LBB)	•	•	•
		ISL isolator discrepancy alarm	-	•	•
		Fibre optic signalling channel	•	•	•
	OptGGIO	Digital inputs	8	16	24
	RlyGGIO	Output relays	8	8	16
		Virtual digital inputs (via fibre communications)	16	16	16
		Virtual output relays (via fibre communications)	16	16	16
		Front communications port (USB)	•	•	•
		Rear communications port (Kbus/EIA(RS)485)	•	•	•
		Second rear communications port (Kbus/EIA(RS)485) *	Option	-	Option
		InterMiCOM teleprotection (with second rear communications port) *	Option	-	Option
		Rear communications port (Ethernet) *	Option	-	Option
		Time synchronisation port (IRIG-B) *	Option	-	-
	FnkGGIO	Function keys	10	-	10
	LedGGIO	Programmable tri-colour LEDs	18	-	18

* Refer to data sheet for model selection

Management Functions

In addition to the protection & control elements, the P740 provides a wide range of measurement, monitoring, post fault analysis and self-diagnostic features:

- Circuit-breaker control
- Trip circuit supervision (using PSL)
- Online measurement
- Plant status monitoring
- Four alternative setting groups
- Programmable scheme logic (PSL)
- Sequence of event recording (SOE)
- Comprehensive fault records (including topology)
- Comprehensive disturbance recording (waveform capture)
- User configurable function keys & hotkeys
- User configurable tri-colour LEDs
- Local and remote communications ports
- Time synchronization
- Fully customizable menu texts
- Multi-level password protection
- Test facilities
- Power-up diagnostics and continuous self-monitoring of the relay
- User-friendly settings, analysis and monitoring software

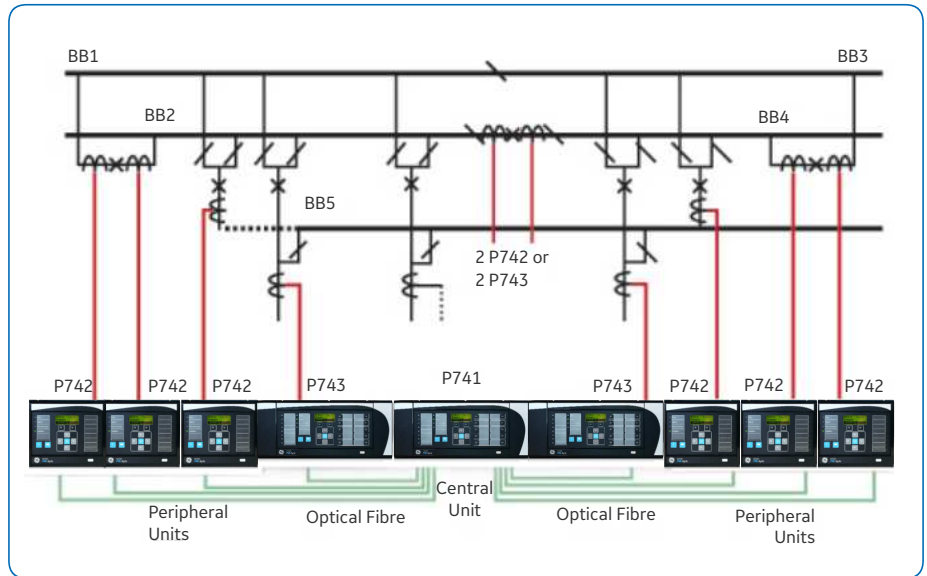

Fig. 1: P740 scheme applied to protecting a double busbar with transfer bus

Functional Overview

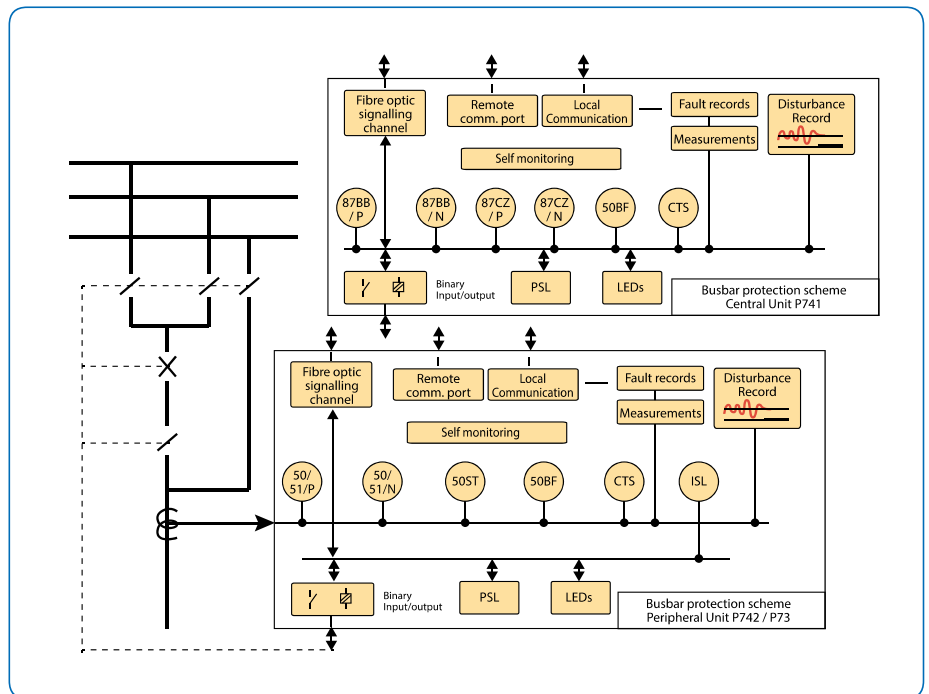

Fig. 2: Functional diagram

Fast, sensitive & secure - P740 - the ultimate in busbar protection

Busbar Differential Protection

The primary protection element of the P740 applies phase segregated biased current differential protection. The technique is based on the numerical application of Kirchoff's law for the selective detection and ultra high-speed isolation of a faulted section of the busbar.

The analysis is carried out in the Central Unit (CU) which communicates with the Peripheral Units (PU) to gather current information from individual circuits and to implement the tripping of circuits as required. This reliable, high-speed communication is achieved via a direct optical connection at 2.5 Mbps.

To ensure the adaptability of the relay to any type of busbar configuration, the P740 is built with a universal topology processing algorithm. This algorithm determines the optimum tripping zone based on the current status of the plant isolators and circuit-breakers.

The P740 employs biased differential algorithms, where the differential current is compared with a bias current. This characteristic ensures the stability of the protection for external faults, even with differing CT tolerances and errors, which could otherwise lead to spurious operation.

To increase the security of the differential protection, the biased differential element is supervised by a biased global check zone element. This ensures stability, even for any erroneous state indication from the auxiliary contact of plant isolators and circuit-breakers.

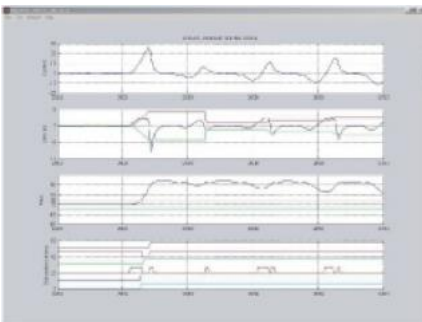

Fig. 3: CT saturation detection

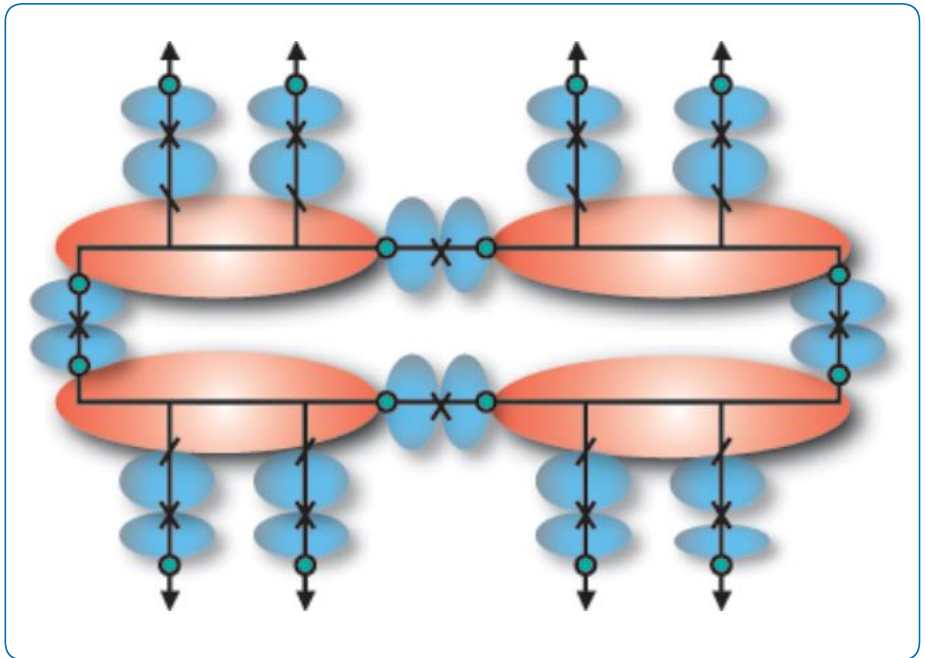
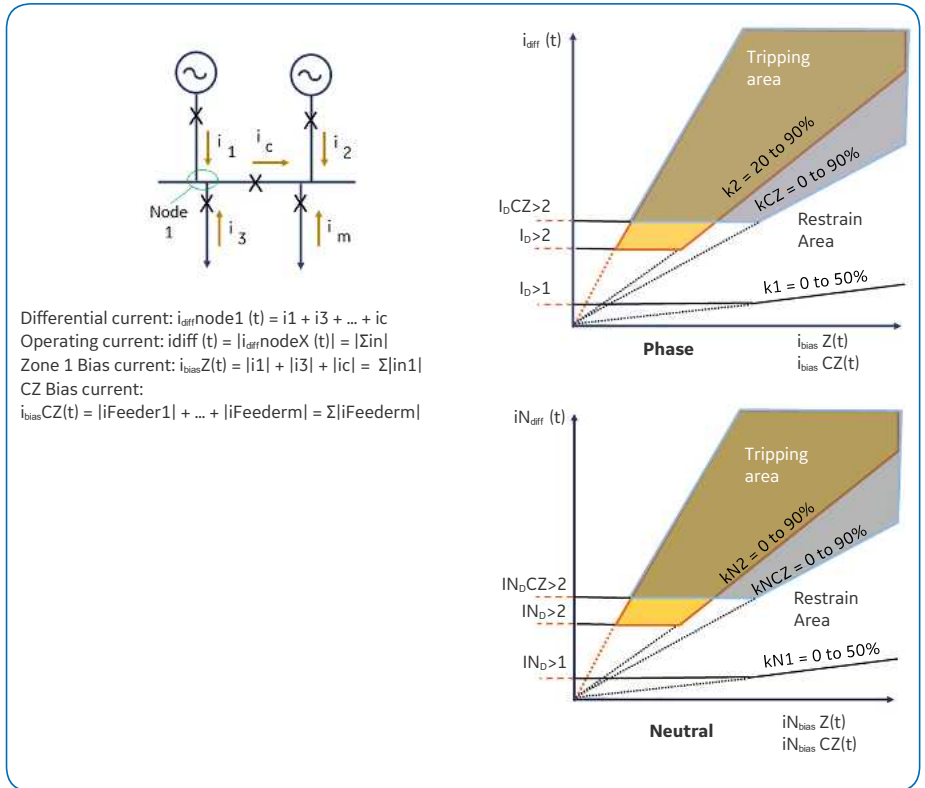

Fig. 4: Universal online topology processing

Fig.5: Bias differential characteristics



The MiCOM Agile P740 also employs CT supervision and an innovative, ultra high-speed, secure CT saturation detection algorithm. This ensures stability when CTs become saturated, particularly under external fault conditions.

This algorithm combines a simulation of the flux built up in the core of the CTs with a recursive consistency variation check. This technique can detect CT saturation in less than 2 ms.

Dual Characteristics

To provide stability for severe through faults while simultaneously detecting low current internal faults, the P740 is equipped with dual characteristics: a phase segregated differential protection and another sensitive earth current differential protection.

Multiple Tripping Criteria

The P740 maintains the highest levels of stability under all conditions, including hardware failure and incoherent signals applied from an external plant or generated by the power system. Any tripping command must be made conditional upon the simultaneous occurrence of 7 to 9 criteria. Magnitude criteria requires confirmation of two simultaneous thresholds per zone:

- Exceeding the bias slope characteristic (k_2)
- Exceeding the differential operating current threshold ($ID > 2$)

Check zone supervision:

The zone element(s) are only permitted to trip if the command is confirmed by the check zone element:

- Exceeding the bias slope characteristic (kCZ)
- Exceeding differential operating current threshold ($IDCZ > 2$)

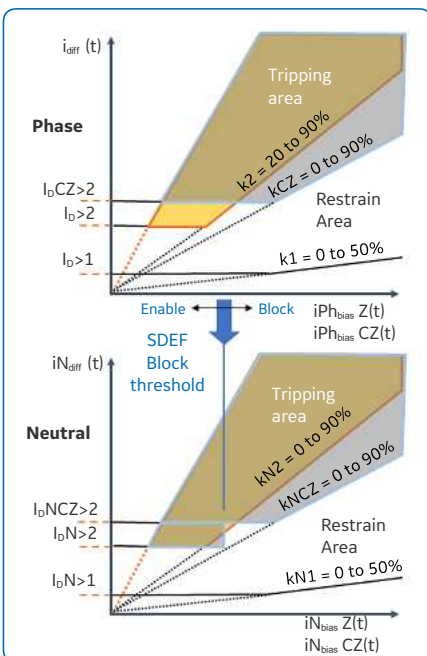

Fig. 6: Dual characteristics

Signal quality criteria:

- No CT saturation detected
- Current variation detected on at least two PUs (except for dead bus)

Time or angular criteria:

The measurement elements on 2 samples are taken at 1200 Hz, where the first sample is taken for the initial measurement and the second sample for trip confirmation.

Local criteria (optional):

The PUs can be set to only authorize tripping if there is confirmation by local overcurrent criteria, undervoltage or zero sequence overvoltage.

Dead Zone or Blind Spot Protection

The current transformers or the open breakers surrounding the busbars define the limits of the main zones. When a feeder circuit-breaker is opened, a dead zone or blind spot is created between the CB and the associated CT. The PU detects this condition automatically and provides protection for this zone. One stage of definite time delayed overcurrent and earth fault protection is provided in each PU to provide this functionality.

Continuous Supervision of Current Circuits

The P740 detects any abnormality in the current circuit by continuously monitoring it. Under normal operating conditions the differential current will be negligible. An anomaly is detected at a threshold, $ID > 1$, which can be set to alarm from 10 A primary.

Differential Current Settings

When switching operations are carried out in the substation, incorrect topology replicas may occur. In this case, a differential current appears. The differential elements of the P740 are allowed to operate only if the differential current reaches a threshold $ID > 2$, which is normally set above the highest load current.

Additional Ultra High Speed External Fault Blocking

Ultra high-speed through fault detection can be carried out in each PU and can generate a control signal from the moment of the first sample (0.4 ms) to block the connected zone before CT saturation.

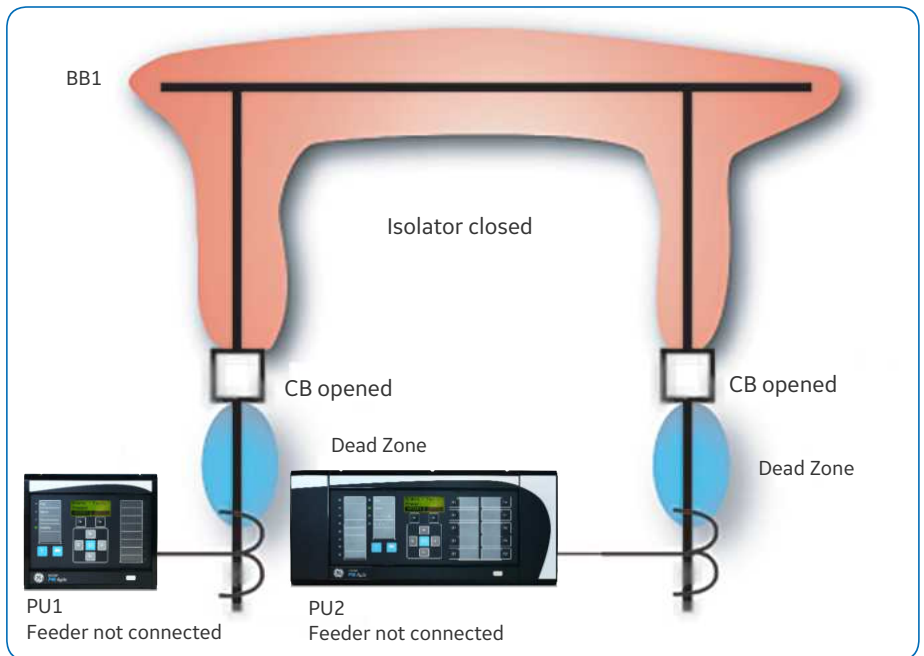

Fig. 7: Dead zone protection

Phase Overcurrent and Earth Fault Protection

Overcurrent and earth fault protection is provided in the PUs. These elements provide additional protection for the individual circuits.

The two stages can be programmed as:

- First stage can be programmed as definite time (DT) delay or one of the nine inverse time (IDMT) curves (IEC/UK and IEEE/US)
- Second stage can only be programmed as definite time.

Circuit Breaker Failure Protection (LBB)

The P740 offers an inbuilt integrated solution for breaker failure protection. This requires all PUs to receive a duplication of the trip commands generated in their associated bay. In general the breaker failure protection is executed on a per phase basis, which involves the possibility of receiving tripping commands on a per pole basis.

The P740 busbar protection scheme can also work in co-ordination with external breaker failure protection relays. In this configuration the receipt of an external breaker failure command results in the tripping of all the adjacent circuit-breakers via the topological recognition system identifying which breaker is connected to which zone.

Current Transformer Mixing Correction

The MiCOM P740 Agile can correct a mix between current transformer ratios over a very wide range up to 40. Its associated user interface provides a range between 1 A and 30 000 A primary.

Since the current transformer ratings in a substation may be of mixed ratios, the P741 uses a virtual CT ratio equal to 1000/1, irrespective of the feeder section concerned.



Fig. 8: S1 Agile: a powerful and intuitive PC toolsuite

Isolation and Maintenance Operating Mode

For ease of operation or maintenance of the busbar protection system, the CU and the PUs can receive specific commands designed to allow system testing or other intervention without any danger of unwanted tripping. In the CU, a centralised command to isolate the busbars at two levels can be selectively applied per zone:

- Differential protection (87BB) blocked (measurements active and 87BB tripping deactivated) - The breaker failure protection (50BF) remains operational
- Differential protection (87BB) and circuit-breaker failure protection (50BF) blocked - The additional local protection functions (51, 51N, etc.) remain operational
- All the protections in the CU and the PUs (87BB, Dead Zone, General 50BF, Local 50BF, O/C, etc.) can also be blocked

A selective two-level command may be applied selectively for each PU:

- Intervention on another bay protection for maintenance and testing - The local breaker failure protection (50BF) is blocked but the busbar protection remains in service - PU in 50BF Blocked mode
- Intervention on the PU for maintenance and testing - PU in Overhaul mode

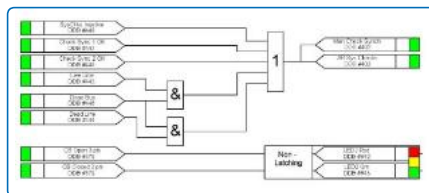

Fig. 9: Programmable scheme logic editor (S1 Agile)

Programmable Scheme Logic

Powerful programmable scheme logic (PSL) allows the user to customise the protection & control functions. It is also used to program the functionality of the optically isolated inputs, relay outputs and LED indications (red or tri-colour). The programmable scheme logic is comprised of gate logic and general purpose timers. The gate logic includes OR, AND and MAJORITY gate functions, with the ability to invert the inputs and outputs and provide feedback. The programmable scheme logic is configured using the graphical MiCOM S1 Agile software as shown below.

Plant Status and Monitoring

Checks and monitoring of the plant status can be made and an alarm raised for any discrepancy condition between the open and closed auxiliary contacts of the isolators and circuit-breakers. The Dynamic Synoptic software allows the user to monitor the position of CBs and isolators in the busbar scheme, as well as currents, alarms, etc.

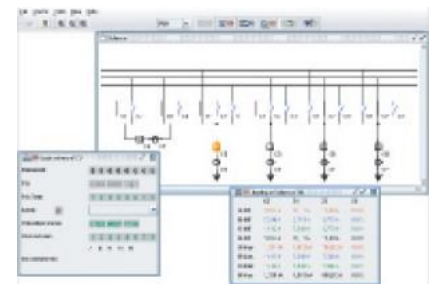

Fig. 10: MiCOM P740 Tool: Dynamic Synoptic

Measurement and recording Facilities

P740 series relays are capable of measuring and storing the values associated with a fault. All the events, fault records and disturbance records are time tagged to 1 ms using an internal real-time clock. An optional IRIG-B port is also provided for accurate time synchronization. Alternatively, Ethernet time synchronization is available.

Measurement

The measurements provided, which may be viewed as primary or secondary values, can be accessed via the backlit liquid crystal display. They are also accessible via the communications ports. The following instantaneous parameters can be viewed:

Central Unit (P741)

- Differential current Idiff / phase / zone
- Bias current Ibias / phase / zone
- Check zone Idiff / phase

Peripheral Units (P742 & P743)

- Phase currents IA IB IC
- Neutral current IN
- Sequence currents
- Frequency

Event Recorder

Up to 512 time-tagged event records are stored and can be extracted via the communications port or viewed on the front panel display.

Fault Recorder

Records of the last five faults are stored in the memory of both the Central and Peripheral Units.

Each fault record includes:

- Indication of the fault zone (CU+PU)
- Protection element operated
- Active setting group
- Fault duration
- Currents and frequency (PU)
- Fault zone differential and bias current (CU)
- Topology at the fault occurrence

Disturbance Recorder

The CU and PUs of the P740 have independent disturbance recording facilities. The PUs can record four analogue and 32 digital channels, whereas the CU stores eight analogue and 32 digital channels, in addition to one time channel.

Specific analogue channels:

- Check zone Ibias / Idiff (CU)
- IA, IB, IC, IN (PU)

Maximum duration of one record and number of records:

- 1.2 s per record and 8 records (CU)
- up to 10.5 s per record and minimum of 50 records 1.5 s (PU)

Disturbance records can be extracted from the relay via remote communications and saved in the COMTRADE format. These records may be examined using MiCOM S1 Agile or any other standard COMTRADE viewer.

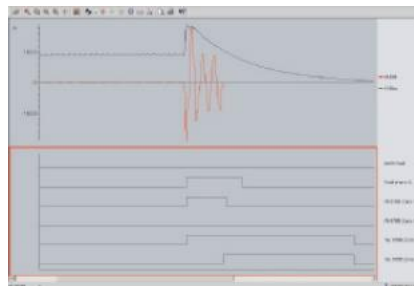

Fig. 11: Disturbance record viewed in S1 Agile

Local and Remote Communications

Two communications ports are available as standard: a rear port providing remote communications and a front USB port providing local communications.

As an option, an Ethernet board can be added in the P741 and P743 to use the IEC 61850-8.1 protocol.

The front USB port is designed for use with MiCOM S1 Agile, which fully supports functions within the relay by: providing the ability to program the settings offline, configure the programmable scheme logic, extract and view events, disturbance and fault records, view the measurement information dynamically and perform control functions (using Courier protocol).

The default remote communications protocol is Courier / RS 485 or K-bus and can be converted to IEC60870-5-103. An optional second rear Courier communications port is also available, which can be configured as RS232, RS485 or K-Bus.

IEC 61850 is available when the optional Ethernet port is ordered. IEC 61850 offers high-speed data exchange, peer-to-peer communications, reporting, disturbance record extraction and time synchronization.

P740 series extends the IEC 61850-8-1 station bus to include Parallel Redundancy Protocol (PRP), and High-availability Seamless Redundancy (HSR) which offers a vendor-interoperable solution to implement redundant communications. It has the advantage of taking zero time to recover from a failure, as parallel alternative paths are continually operative.

Fast, trusted and proven busbar differential protection - with an extensive, global installed base

IEC 61850-9-2 Process Bus Interface (P743 Only)

An optional process bus interface is available, allowing the relay to receive current and voltage sampled data from non-conventional instrument transformers such as optical and Rogowski devices. In other digital substation architectures, the -9-2 data is generated by merging units in the yard, which digitise conventional 1 A/5 A and 100/120 V secondaries, for safer and more economical cross-site communications with IEDs via fibre optics. Grid Solutions' -9-2 implementation has been designed to be especially resilient and reliable in the presence of "noise", such as latency, jitter or missing/suspect data.

InterMiCOM (optional)

InterMiCOM allows the transfer of any digital status information between relays. Intertripping is supported too, with channel health monitoring and cyclical redundancy checks (CRC) on the received data for maximum message security.

InterMiCOM provides eight end-end signals, assignable to any function within a MiCOM relay's programmable logic. Default failsafe states can be set in case of channel outages. The physical format for InterMiCOM is EIA (RS) 232 for MODEM links.

Diagnostics

Automatic tests performed, including power-on diagnostics and continuous self-monitoring, ensure a high degree of reliability. The results of the self-test functions are stored. Test features available in the user interface allow examination of input quantities and states of the digital inputs and relay outputs.

Quality Built-In (QBI)

Grid Solutions' QBi initiative has deployed a number of improvements to maximise field quality. Harsh environmental coating is applied to all circuit boards to shield them from moisture and atmospheric contamination. Transit packaging has been redesigned to ISTA standards and the fourth generation of CPU processing boosts not only performance, but also reliability.

Hardware

All models in the MiCOM Agile P740 series relays include:

- A backlit liquid crystal display
- LEDs (12 for the P742 and 18 tri-colour for the P741 and P743)
- Function keys (P741 and P743)
- Hotkeys
- Optional IRIG-B port (CU)
- USB (front port) & RS485 / K-bus (rear port)
- Fibre optic connections from the CU to the PUs
- Download/monitor port
- N/O and C/O watchdog contacts
- Dual rated CT inputs 1A/5A
- Universal opto inputs with programmable voltage threshold
- Optional Ethernet rear communications board (P741 & P743)
- Optional redundant Ethernet ports (IEC 61850)

Redundant Ethernet is available, optionally, managed by the market's fastest recovery time protocols. IEC 62439 PRP, HSR and RSTP are available, offering multi-vendor interoperability. The redundant Ethernet board has a watchdog relay contact and an SNMP interface to alarm in case of a failure. The Ethernet port options support modulated or demodulated IRIG-B, IEEE1588 and the SNTP protocol for time synchronization.

Depending on the relay model, up to eight high-speed high-break contacts are available as an option. This will protect against burnt contacts due to a stuck breaker or in defective breaker auxiliary contact conditions.

MiCOM P40 Agile

Grid Solutions' philosophy is one of continuous improvement in our products and solutions. Our emphasis on communications in MiCOM has become a focus which secures our leadership in digital substations. To mark this phase of evolution, the brand "P40 Agile" is applied to the range.

Device Track Record

Low impedance biased differential busbar protection, MBCZ, launched in 1988

Since the launch of P740 in 2002, more than 3,000 schemes (1xCU + several PUs) have been delivered

For more information please contact
GE
Grid Solutions

Worldwide Contact Center

Web: www.GEGridSolutions.com/contact
Phone: +44 (0) 1785 250 070

GEGridSolutions.com

IEC is a registered trademark of Commission Electrotechnique Internationale. IEEE is a registered trademark of the Institute of Electrical Electronics Engineers, Inc.

GE and the GE monogram are trademarks of General Electric Company.

GE reserves the right to make changes to specifications of products described at any time without notice and without obligation to notify any person of such changes.

P740-Brochure-EN-2020-12-Grid-GA-0693. © Copyright 2020, General Electric Company. All rights reserved.



Imagination at work