

MiCOM Agile P44T



Catenary Distance Protection

Many high speed, regional and urban rail networks worldwide are electrified. The exposed nature of overhead catenaries makes them fault-prone and protection devices are vital for selective tripping and isolation of any faulted section.

The MiCOM P44T Agile detects and trips faults in less than one power system cycle. This minimises the risk of downed conductors, making successful supply restoration more likely and ultimately minimising delays to trains.

The P44T is a powerful multifunctional device, supplementing distance main protection with a host of backup protection, thermal protection, recording, control, measurement and monitoring features. A range of communications options caters for all applications from simple retrofits up to full digital substation integration.

Key benefits

- True subcycle distance tripping
- Protection of classic or auto transformer-fed catenaries in systems with nominal frequencies of 50 or 60 Hz (settable)
- Advanced load blinding which prevents false tripping due to encroachment of heavy loads
- Integral digital teleprotection between line ends
- Auto reclose to supplement the main distance function
- Wrong phase coupling, panto flash over and train startup protection
- Delta I protection elements reliably detect high impedance faults by detecting a sudden current step change.
- Cybersecurity aligned to industry standards and services (NERC® CIP, AAA, RADIUS, RBAC, Syslog)

Application

The P44T is designed for protection of classic or auto transformer-fed catenaries in systems with nominal frequencies of 50 or 60 Hz (settable).

Protection and Control

- Distance high speed operation in less than one cycle
- Load blinder prevents spurious trips cascading through the network
- Integral digital teleprotection between line ends
- Defrost and panto flashover protection
- Delta I protection for high impedance faults
- Multi-shot autoreclosure with check synchronism and adaptive breaker closing

Advanced Communications

- InterMiCOM option for end-to-end protection communications; Readily interfaces with end-to-end communications channels (56/64 kbps)
- Wide range of supported protocols Courier/K-Bus, IEC 60870-5-103, DNP 3.0 (EAI-485 or Ethernet) and IEC 61850 Ed.1 or Ed.2
- Redundant communications with zero downtime using optional PRP/HSR technology
- Supports PRP, HSR and RSTP in one model, allowing a single P40 model to be used in any application requiring redundant Ethernet communications
- HSR Ring upto 50 node support for larger substation architectures
- Fast performance, particularly in onerous applications such as where process bus GOOSE is used for tripping purposes



Functional Overview

ANSI	IEC 61850	Features	P44T			
			A	B	C	D
		Case size	60TE	60TE	80TE	80TE
	OptGGIO	Optocoupled logic inputs	16	16	24	24
	RlyGGIO	Relay output contacts	16	8	32	16
		High speed, high break contacts		4		8
	PTRC	Tripping mode - single or two poles		1 ph / 2 ph		
21P / 21G	PDIS	Distance zones		5		
		Characteristics Phase Ground		Quad		
		CVT transient overreach elimination		X		
		Load blinder		X		
		Easy setting mode		X		
85	PSCH	Communication-aided schemes, PUTT(PUR), POTT(POR) Blocking, Weak Infeed		X		
		Accelerated tripping - loss of load and zone 1 extension		X		
50/27	PSOF	Switch on to fault		X		
		Defrost protection		X		
	PHIZ	Delta I high impedance		X		
50 / 51 / 67	OcpPTOC/RDIR	Catenary or feeder overcurrent stages		4		
49	PTTR	Thermal protection		X		
27	PTUV	Undervoltage protection stages		2		
59	PhsPTOV	Overvoltage protection stages		2		
50BF	RBRF	High speed breaker fail		X		
VTS		Voltage transformer supervision		X		
79	RREC	Autoreclose - shots supported		4		
25	RSYN	Check synchronism		X		
		No. of breakers controlled		1		
		Alternative settings groups		4		
FL	RFLO	Fault locator		X		
		Fault records		15		
		SOE event records		1024		
	RDRE	Disturbance recorder, samples per cycle		48		
		Number of channels in Disturbance recorder Analogue / Digital		16/64		
	XCBR	Circuit-breaker condition monitor		X		
		IRIG-B time synchronism		(X)		
		InterMiCOM teleprotection		(X)		

Key (x) : denotes optional

Functional Overview Diagram

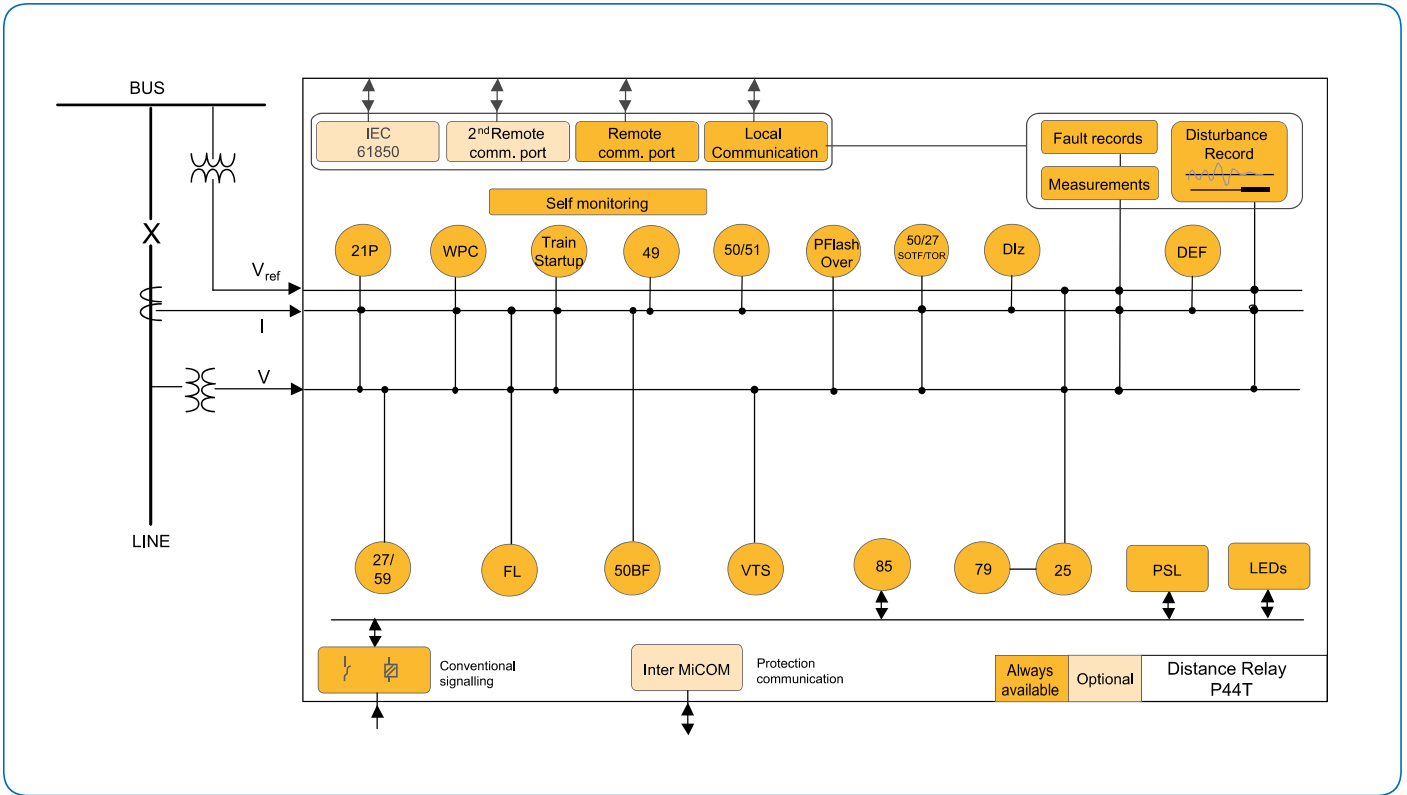

Figure 1 System overview of P44T



Versatile protection
for universal application

Friendly configuration to simplify
the job of the protection engineer

Main Protection Functions

The MiCOM P44T Agile provides fast, highly selective railway catenary protection. Advanced load blinding and disturbance detection techniques ensure stability when no tripping is required.

Multiple main protection elements reside inside each relay:

Distance Protection

Five zones of protection are provided as shown in Figure 3. Quadrilateral characteristics allow versatile deployment as the main protection for all AC catenary/feeder systems. The quadrilateral characteristics provide enhanced fault arc resistance coverage, covering typical fault scenarios such as bird strikes, vegetation/debris, vandalism, flashover to structures etc.

Each zone has independently settable right hand and left hand side resistive reaches. This adapts the application to suit routes hosting regenerative braking trains. Without the means to boost the left hand reach, faults might experience a phase angle shift and risk being undetected if neighbouring trains are connected as regen infeed(s).

In instances where wrong-phase coupling is required to detect the inadvertent paralleling of out-of-phase neighbouring feeds, a distance zone is applied at a new characteristic angle (deliberate 'off-angle' fault detection).

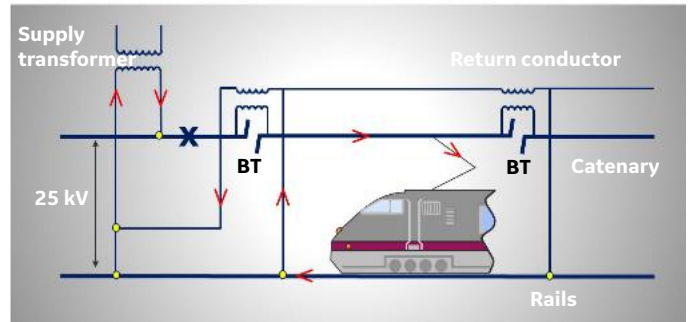

Figure 2 Example classical single-phase application

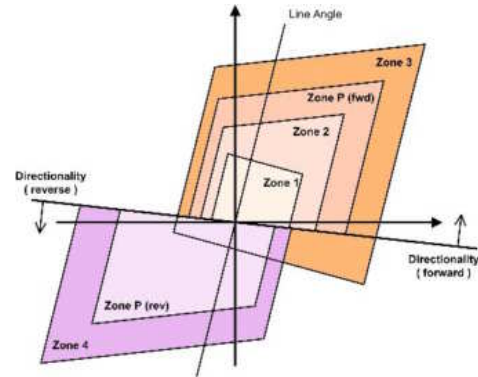

Figure 3: Quadrilateral characteristics

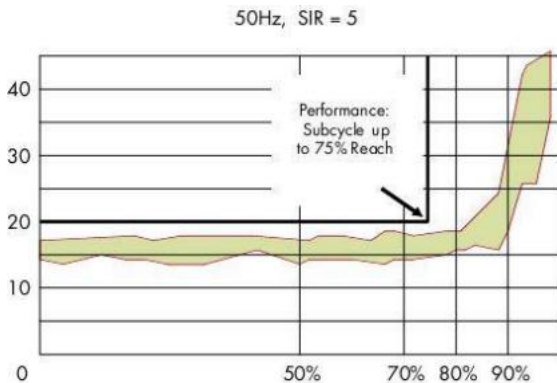

Figure 4 P44T Example min-max timing contour, 50 Hz, SIR=5

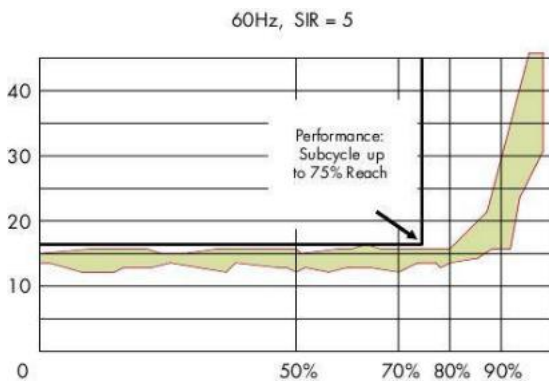

Figure 5 P44T Example min-max timing contour, 60 Hz, SIR=5

Blinder characteristics and inrush detectors prevent false tripping due to encroachment of heavy loads. Combined with the directional decision from a proven delta principle, secure operation of distance zones is assured. The trip time is typically 0.7 to 1 cycle for the P44T.

High Speed - High Break Contacts

The trip times shown in Figures 4 and 5 relate to a P44T with standard relay contacts and include the contact closure time. When fitted with High Speed-High Break (HSHB) contacts, all trip times are reduced by 3 to 4 ms. The trip time for P44T becomes 10 to 17 ms. HSHB contacts easily rupture repetitive shots of 10 A trip or closed coil currents.

Main Protection Schemes

Basic scheme logic for standalone operation (without a signaling channel)

Trip on close logic allows accelerated tripping to be selected following manual, or auto-re-close

Carrier Aided Scheme Includes:

- Direct transfer tripping
- Permissive underreach scheme (PUR)
- Permissive overreach (POR) with open breaker, weak infeed
- echo logic and weak infeed trip feature
- Blocking scheme
- User-defined custom schemes
- Defrost Protection

In cold countries, ice build-up on the catenary may be an issue if the headway between trains is long. In such cases, the control operator can switch the feeding arrangement temporarily to apply a instant, deliberate short-circuit – to warm the contact wire and melt any icicles which could otherwise foul pantographs. In the brief period that this feeding mode is in operation, the P44T can invoke a differential element to protect the loop (Figure 6).

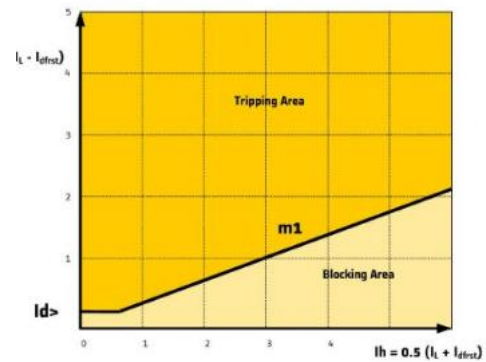

Figure 6 Defrost characteristics

High Impedance Delta Protection

The fault current in cases of high fault impedance could be smaller than the maximum load current which contains 3rd and some 5th harmonic due to the use of static converters in the locomotives. The P44T provides a Delta I high impedance protection that detects the sudden current change and it is supervised by the presence of 3rd and 5th harmonic as well as an impedance characteristic.

Backup Protection

- Four stages of phase fault protection
- Phase under/overvoltage protection
- Two stages of high speed circuit breaker failure protection

Phase and Earth Fault Overcurrent

In addition to definite time and predefined IDMT curve selection, the P44T supports user programmable curves for customised operation and resetting. The profile can be chosen to optimise the protection, without constraining the feeder's load ability. If a standard curve is not suitable for the application, the user can program and upload a custom variant. (See Figure 7)

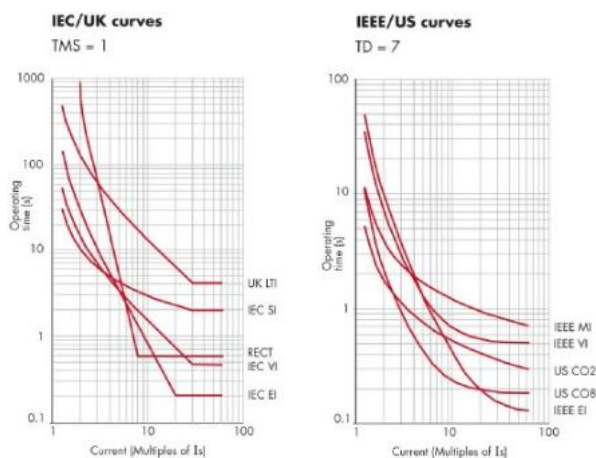

Figure 7 IEC and ANSI/IEEE inverse time curve profiles

Thermal Protection

It is important that the catenary is not allowed to overheat, as this will lead to loss of the correct contact wire mechanical position above track, or conductor sagging. The P44T relay incorporates a current based thermal replica, using load current to model heating and cooling of the protected catenary. The element can be set with both alarm and trip stages.

InterMiCOM (Optional)

InterMiCOM allows high performance permissive and blocking type unit protection to be configured, plus transfer of any digital status information between line ends. Intertripping is supported too, with channel health monitoring and cyclic redundancy checks (CRC) on the received data for maximum message security.

InterMiCOM provides eight end-to-end signals, assignable to any function within a GE's MiCOM relay's programmable logic. Default failsafe states can be set in case of channel outages.

Two physical formats for InterMiCOM are possible:

- EIA (RS) 232 for MODEM links
- InterMiCOM64 at 56/64 kbit/s for direct fibre or multiplexed links.

InterMiCOM⁶⁴ also includes support for 3-terminal applications. 850 nm fibre communication is used to interface to multiplexers in IEEE C37.94 format (and to G.703 (64 kbps, E1 2 Mbps), V.35 and X.21 via P590 interfaces). 1300 nm channel options are used for direct fibre teleprotection. End-end transfer time of permissive or blocking scheme data is typically only 5 ms for InterMiCOM⁶⁴.

Circuit-breaker Control

Circuit-breaker control is available from the front panel user interface, optically isolated inputs and remotely via the substation communications. Ten function keys are available for direct actions instigated by users. The F-keys operate in two modes, normal and toggled, activating associated signals in PSL that are used to customise the application or operative mode.

Autoreclose and Check Synchronism

Where permitted, the MiCOM P44T Agile can control the return to service of catenaries with transient faults. The autoreclose function may be supervised by check synchronism or simple live bus/dead line or dead line/live bus logic as per operational practices.

Opto Inputs

The relay’s digital (opto) inputs are hardened against interference in the substation environment. Programmable pickup thresholds prevent spurious detection during events such as EMC noise or substation battery earth faults.

Supervisory and Condition Monitoring Functions

Two stage circuit-breaker failure protection, CT / VT supervision, circuit- breaker condition monitoring and trip circuit supervision are available. Supervision of the trip circuit in both circuit-breaker open and closed states can be realised using the optically isolated inputs and programmable scheme logic.

Logic and Control Capabilities

All aspects of the MiCOM P40 family IED configuration are managed using S1 Agile software. (Figure 8)



Figure 8 S1 Agile a powerful and intuitive PC tool suite

Programmable Scheme Logic (PSL) Powerful graphical logic allows the user to customise the protection and control functions. It is also used to program the optically isolated inputs, relay outputs and LEDs. The logic includes OR, AND and majority gates, timers and set/reset latch functions, with the ability to invert the inputs and outputs and provide feedback. The PSL imposes no delay on logic throughput, with concurrent processing being used instead of sequential equations – thus avoiding any logic ‘race’ issues. (Figure 9).

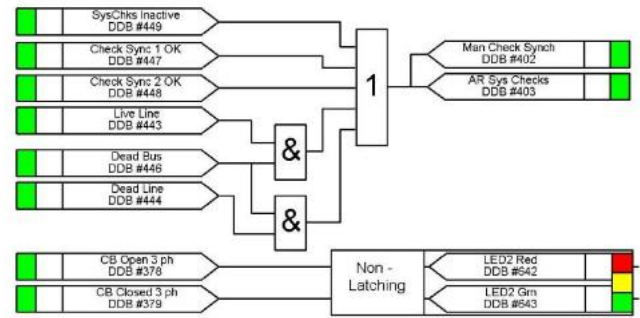

Figure 9 Programmable scheme logic

Measurements, Recording and Post-fault Analysis

All events, fault and disturbance records are time tagged to a resolution of 1 ms. Up to 1024 timetagged event records are stored in the flash memory and can be extracted using the communications ports or viewed on the front panel display. The oscillography includes all analogue channels, 64 digital and 1 time channel - all at a resolution of 48 samples/cycle. Disturbance records can be extracted from the relay via the remote communications and saved in COMTRADE format. Records of the last 15 faults are stored in non-volatile memory.

Fault records contain:

- Indication of the faulted phase
- Protection operation
- Active setting group
- Fault location (distance to fault)
- Relay and CB operating time
- Pre-fault and fault currents, voltages and frequency

The measurements provided, which may be viewed in primary or secondary values, can be accessed via the front panel LCD display, or the communications ports.

Power and energy metering and maximum demand monitoring is provided for indication purposes and load trend analysis.

Fault location

A fault location algorithm provides distance to fault in miles, kilometres, ohms or percentage of the line length. This proven algorithm tolerates pre-fault loading and fault arc resistance.

The inclusion of function keys, ancillary supervision and tri-colour LEDs saves panel space

Plant Supervision

- Circuit Breaker Condition Monitoring
- Monitors the number of breaker trip operations
- Records the sum of broken current quantities (interruption duty)
- Monitors the breaker operating times

Quality Built-in (QBi)

GE's QBi initiative has deployed a number of improvements to maximise field quality. Harsh environmental coating is applied to all circuit boards to shield them from moisture and atmospheric contamination. Transit packaging has been redesigned to ISTA standards and the third generation of CPU processing boosts not only performance, but also reliability.

Case Size

MiCOM P44T relays are housed in full 80TE cases, for 19" racks or flush mounting, or in 60TE (12") case widths.

Local and Remote Communications

Two communications ports are standard: a rear port providing remote communications and a front port for substation staff. The front port facilitates: the programming of settings, configuration of the programmable scheme logic, extraction and viewing of event, disturbance and fault records, viewing of measurements and the instigation of control functions. Any of the protocols listed below can be chosen at the time of ordering:

- Courier / K-Bus
- IEC 60870-5-103
- DNP 3.0 (EIA-485 serial or Ethernet)
- IEC 61850 (100 Mbit/s Ethernet)

IEC 61850 or DNP 3.0 over Ethernet are available when the optional Ethernet port is ordered. IEC 61850 offers: high-speed data exchange, peer-to-peer communications, reporting, disturbance record extraction and time synchronisation. MiCOM P44T Agile offers best-in-class GOOSE performance. Redundant Ethernet is available, optionally managed by the market's fastest recovery time protocols: 'self-healing' ring and 'dual homing' star, allowing bumpless redundancy. IEC 62439 PRP, HSR and RSTP are also available, offering multi-vendor interoperability. Parallel Redundancy Protocol (PRP) offers a vendor-interoperable solution to implement redundant communications. It has the advantage of taking zero time to recover from a failure, as parallel alternative paths are continually operative. This compares to 25 ms or more healing time for legacy techniques such as RSTP.

Second Rear Courier Port

The optional second port is designed typically for dialup modem access by protection engineers/operators, when the main port is reserved for SCADA traffic.

Device Track Record: High Speed Distance Protection

MiCOMho subcycle distance protection deployed on EHV systems since 1983. Over 12 000 relays supplied. Very fast mho characteristic relay.

Quadramho distance protection launched in 1984, adding quadrilateral characteristics to the range.

Optimho universal mho and quadrilateral relays launched in 1989. Over 11 500 units delivered.

Numerical implementation and phase selection proven in sub-cycle LFDC, LFZP and LFZR relays.

Approximately 47 000 P44x family distance relays delivered since launch in 1999.

56/64 kbit/s teleprotection proven in over 44 000 P540 series units delivered.

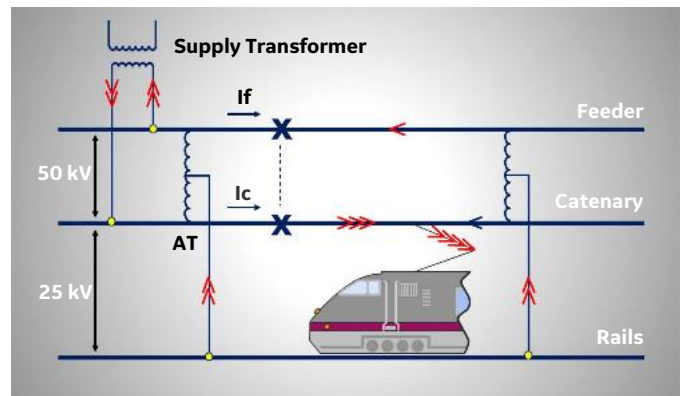

Figure 10 Example of auto-transformer application

Accurate fault location and high-resolution disturbance recording assist post-fault analysis by maintenance crews

For more information please contact
GE Power
Grid Solutions

Worldwide Contact Center

Web: www.GEGridSolutions.com/contact
Phone: +44 (0) 1785 250 070

GEGridSolutions.com

IEC is a registered trademark of Commission Electrotechnique Internationale. IEEE is a registered trademark of the Institute of Electrical Electronics Engineers, Inc. Modbus is a registered trademark of Schneider Automation.

GE and the GE monogram are trademarks of General Electric Company.

GE reserves the right to make changes to specifications of products described at any time without notice and without obligation to notify any person of such changes.

P44T-Brochure-EN-2020-10-Grid-GA-0666. © Copyright 2020, General Electric Company. All rights reserved.



Imagination at work