

MiCOM Agile P141, P142, P143 & P145

Feeder Management Relays

P14x is an integrated solution for the complete protection, control and monitoring of overhead lines and underground cables from distribution to transmission voltage levels.

The wide range of auxiliary functions provides the user with sufficient information to efficiently maintain the power system and its components, including circuit-breakers, CTs, VTs, etc.

A customisable, friendly, multi-lingual user interface and programmable graphical scheme logic allow simple and flexible applications on any network. In addition, the P145 has integrated user function keys and tri-colour programmable LEDs, which provide a cost-effective solution for full feeder scheme applications.

Use the function keys to replace control scheme switches and save on engineering time and wiring costs.

With optional High-Speed/High-Break contacts, the high break performance ensures no burn-out of contacts during normal operations or situations such as breaker failure or defective CB auxiliary contacts. The need for external electromechanical trip relays can be reduced/removed by transferring the high rating and durability duties to the MiCOM device, thus providing further application and cost benefits.

Connecting the relay to virtually any kind of substation automation system or SCADA is made possible by the wide range of updated communications protocols, including IEC 61850.

A range of hardware interfaces are available for easy integration into any new or legacy system.

The MiCOM P14x Agile series extends the IEC 61850-8-1 station bus to include Parallel Redundancy Protocol (PRP), and High-availability Seamless Redundancy (HSR) which offers a vendor-interoperable solution to implement redundant communications. It has the advantage of taking zero time to recover from a failure, as parallel alternative paths are continually operative. This compares to 25 ms or more healing time for legacy techniques such as Rapid Spanning Tree Protocol (RSTP).

The P14x Agile supports IEC Edition 1 & 2 compliance, comprehensive test mode and simulation capability, editable IEC 61850 Logical Device and Logical Node naming, PTP (IEEE 1588) time synchronisation, and SNMP.



Protection and Control

- Feeder protection for solidly, impedance, Petersen coil earthed and isolated systems
- 9 stages of advanced load shedding and restoration logic
- Single box solution for high impedance busbar protection with integrated buswire supervision
- Digital inputs - deliver ESI 48-4 EB2 noise immunity and are suitable for H7 trip circuit supervision

Application Flexibility

- 1 A and 5 A in the same relay
- Programmable function keys and LEDs (P145)
- Customisable menus
- Control of up to 9 switchgear elements
- Harsh environmental coating as standard

Advanced Communications

- Wide range of supported protocols Courier/K-Bus, Modbus, IEC 60870-5-103, DNP 3.0 (RS485 or Ethernet) and IEC 61850
- Latest communication protocol implementation with IEEE 1588 precision-time (PTP)
- Software switchable between IEC 61850 Ed. 1 / Ed. 2 support.
- Redundant communications with zero downtime using optional PRP/HSR protocols

Cyber Security

- Enhanced compliance with NERC CIP, NISTIR 7628 and EU NIS foundation norms
- Role-based access control using the industry-standard Radius protocol
- Secure Syslog audit trail recording



Protection Functions Overview

IEC 61850			P141	P142	P143	P145
50/51/67	OcpPTOC/RDIR	Directional/non-directional, instantaneous/time delayed phase overcurrent (6 stage)	•	•	•	•
50N/51N/67N	EfdPTOC/EfmPTOC	Directional/non-directional, instantaneous/time delayed, measured earth fault (4 stage)	•	•	•	•
67N	SenEftPTOC	Sensitive directional earthfault (SEF/ Cos I Sin) (4 stage)	•	•	•	•
67W	SenEftPTOC	Wattmetric earth fault	•	•	•	•
YN		Neutral admittance protection	•	•	•	•
64	SenRefPDIF	Restricted earth fault	•	•	•	•
		Blocked overcurrent	•	•	•	•
		Selective overcurrent	•	•	•	•
		Cold load pick-up	•	•	•	•
51V		Voltage controlled overcurrent	•	•	•	•
51R		Voltage restrained overcurrent	•	•	•	•
46	NgcPTOC	Directional / non-directional negative sequence overcurrent	•	•	•	•
49	ThmPTTR	RMS thermal overload (single / dual time constant)	•	•	•	•
37P / 37N		Phase and neutral undercurrent	•	•	•	•
27	VtpPhsPTUV	Undervoltage (4 stage)	•	•	•	•
59	VtpPhsPTOV	Overvoltage (4 stage)	•	•	•	•
59S	VtpResPTOV	Sensitive overvoltage (2 stage) for buswire supervision	•	•	•	•
59N	VtpResPTOV	Residual overvoltage (neutral displacement) (4 stage)	•	•	•	•
47	NgvPTOV	Negative sequence overvoltage	•	•	•	•
81U	PTUF	Underfrequency (9 stage) - Advanced	•	•	•	•
81O	PTOF	Overfrequency (9 stage) - Advanced	•	•	•	•
81R	PFRC	Rate of change of frequency protocol (9 stage) - Advanced	•	•	•	•
81RF		Frequency supervised rate of change of frequency (9 stage) - Advanced	•	•	•	•
81RAV		Average rate of change of frequency (9 stage) - Advanced	•	•	•	•
		Freq. based load restoration (9 stage) - Advanced	•	•	•	•
		Rate of change of voltage protection (2 stage)	•	•	•	•
BC		Broken conductor (open jumper)	•	•	•	•
50BF	RBRF	Circuit-breaker failure	•	•	•	•
VTS		Voltage transformer supervision (1, 2 & 3-phase fuse failure detection)	•	•	•	•
CTS		Current transformer supervision	•	•	•	•
49SR		Silicon rectifier overload protection	•	•	•	•
79	RREC	4 shot three-pole auto reclose		•	•	•
25	RSYN	Check synchronising			•	•
	2 nd Harm Block	2 nd harmonic blocking	•	•	•	•
32R/32L/32O		Phase segregated power	•	•	•	•
		Sensitive power	•	•	•	•
87		High impedance differential protection	•	•	•	•
	FnkGGIO	Function keys	•	•	•	10
	LedGGIO	Programmable LEDs (tri-colour)	•	•	•	18
	OptGGIO	Digital inputs (maximum) *	8	16	48	32
	RlyGGIO	Output relays (maximum) (Hi Break - Hi Speed option available)*	8	15	32	32
		Front port communication (USB)	•	•	•	•
		Rear communications port (RS485/Optic/Ethernet) *	•	•	•	•
		Second rear communications port (RS232/RS485) *	(+)	(+)	(+)	(+)
		Universal IRIG-B input for time synchronisation (modulated un-modulated)*	(+)	(+)	(+)	(+)
		InterMiCOM teleprotection for direct relay - relay communication EIA(RS) 232 for MODEM links up to 19.2 kbit/sec	(+)	(+)	(+)	(+)

* It may not be possible to get all in one particular model, refer data sheet for model selection

- Standard
- (+) Option

Application

The MiCOM P14x Agile range is suitable for all applications where overcurrent protection is required. It is suitable for solidly earthed, impedance earthed, Petersen coil earthed and isolated systems.

The first application shows a parallel transformer protection where the P141 replaces many of the discrete protection elements normally associated with the LV side of the transformer. The protection includes non-directional and directional phase overcurrent and earth fault, restricted earth fault and circuit-breaker failure protection. The second application shows a P143 protecting a plain feeder using phase overcurrent, sensitive earth fault, negative sequence overcurrent, thermal protection and breaker failure protection. The integral autorecloser with check synchronising can be configured to grade with downstream reclosers.

The MiCOM P145 relay is especially suitable where a complete scheme solution is required and comprises function keys for integral scheme control functionality.

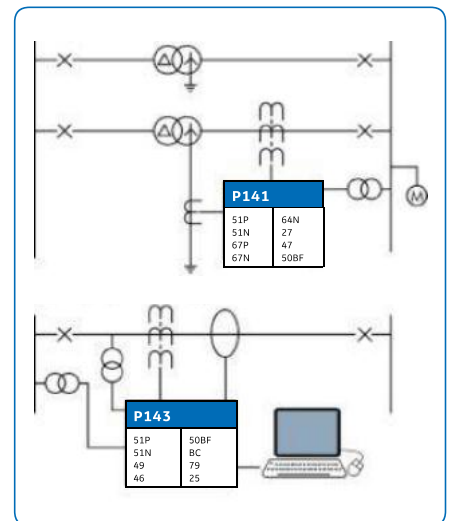

Typical applications of P14x

Management Functions

In addition to the wide range of protection functions listed in the table, all relays in the P14x range are provided with the following measurement, control, monitoring, post fault analysis and self-diagnostic functions:

- Measurement of all instantaneous & integrated values
- Circuit-breaker control, status & condition monitoring
- Trip circuit and coil supervision
- 4 alternative setting groups
- Control inputs
- Fault locator

- Programmable scheme logic
- Programmable allocation of digital inputs and outputs
- Sequence of events recording
- Comprehensive disturbance recording (waveform capture)
- User configurable LEDs
- Local and remote communications ports
- Multiple communications protocol and interface options
- Time synchronisation
- Fully customisable menu
- Multi-level password protection
- Power-up diagnostics and continuous self-monitoring of relay
- User-friendly settings and analysis software
- Read-only mode
- Enhanced opto input time stamping
- Check synchronising with optional compensation for CB closing delay - contacts touch at optimal synchronisation

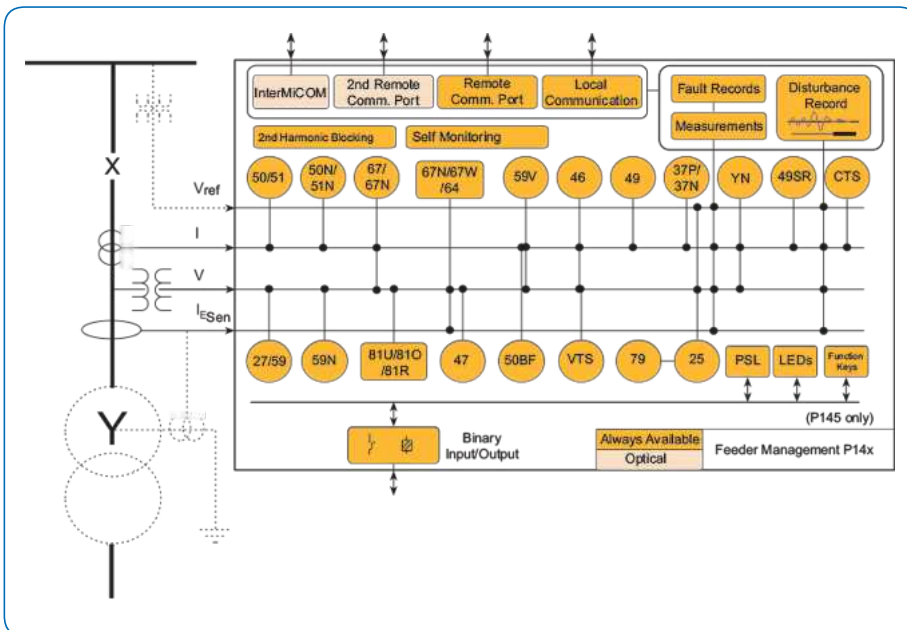

Functional overview
(See Protection Functions Overview for description of ANSI codes)

Phase Overcurrent

Six independent stages are available for each phase overcurrent element. Each stage may be selected as non-directional or directional (forward/ reverse). All stages have definite time delayed characteristics and three of the stages may also be independently set to one of ten IDMT curves (IEC and IEEE). A user-programmable curve tool is provided within the S1 Agile tool suite. The tool can be used to provide customised Operate/Reset curves, providing additional flexibility and allowing the use of the total feeder capacity with complete protection.

If a standard curve is not suitable for the application, the user can program and upload a customised curve to the relay.

The IDMT stages have a programmable reset timer for grading with electro-mechanical relays, to reduce autoreclose dead times and to reduce clearance times where intermittent faults occur.

The phase fault directional elements are internally polarised by quadrature phase-phase voltages and will make a correct directional decision down to: 0.5 V ($V_n = 100 - 120$ V) or 2.0 V ($V_n = 380 - 480$ V).

A synchronous polarising signal is maintained for 3.2 s after voltage collapse to ensure that the instantaneous and time delayed overcurrent elements operate correctly for close-up 3-phase faults.

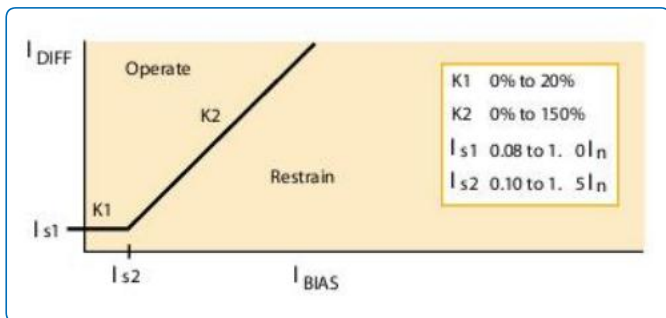

REF biased differential characteristics

Standard Earth Fault

There are two standard earth fault elements, each with four independent stages:

- The first element operates from measured quantities - Earth fault current which is directly measured using a separate CT, or residual connection of the three line CTs.
- The second standard earth fault element operates from a residual current that is derived internally from the summation of the 3-phase currents.

All earth fault elements have the same directionality and IDMT characteristics as the phase overcurrent element. Both earth fault elements may be enabled at the same time providing directional earth fault protection and back-up standby earth fault protection in the same device. The directionality of the earth fault elements is provided by either residual voltage or negative sequence voltage.

Sensitive Earth Fault

A core balance CT should be used to drive the sensitive earth fault function. The directionality of the sensitive earth fault element is provided by the residual voltage.

Wattmetric

As an alternative to the directional earthfault characteristic, a directional I_{cos} characteristic can be used for Petersen coil earth fault protection using the sensitive earth fault input.

Economical Busbar Protection

Each stage of overcurrent and earth fault protection can be blocked by an optically isolated input. This enables overcurrent and earth fault protection to integrate into a blocked overcurrent busbar protection scheme.

Cold Load Pick-up Logic

Cold load pick-up temporarily raises the overcurrent settings following closure of the circuit-breaker, allowing the protection settings to be set closer to the load profile.

Restricted Earth Fault

Restricted earth fault (REF) provides protection for transformer faults, avoiding the need to install a separate discrete relay. It can operate in high or low impedance differential mode.

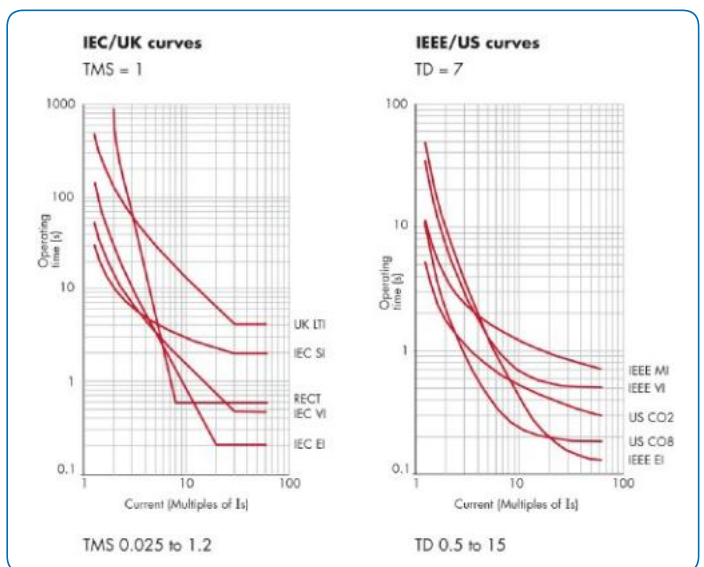

Choice of IDMT characteristics

2nd Harmonic Blocking

The 2nd harmonic blocking detects high inrush current inflows that occur when transformers or machines are connected. The function will block the phase overcurrent, earth fault, sensitive earth fault and negative sequence overcurrent.

Voltage Controlled Overcurrent/ Voltage Restrained Overcurrent

In order to provide backup protection for phase faults, an element is included which can be set as either voltage controlled overcurrent or voltage restrained overcurrent. The timing characteristic can be set as either definite time or IDMT.

Negative Sequence Overcurrent

Negative sequence overcurrent protection can be set as either non-directional or directional (forward /reverse) and can operate for remote phase-phase and phase earth faults even with delta-star transformers present.

RMS Thermal Overload

Thermal overload protection provides both alarm and trip stages. The thermal element may be set with either a single time constant characteristic for the protection of cables or dry transformers, or a dual time constant characteristic to protect oil-filled transformers. In the event of loss of auxiliary supply, the thermal state is stored in non-volatile memory.

Under/overvoltage & Rate of Voltage Change

Under/overvoltage protection may be configured to operate from either phase-phase or phase-neutral quantities. Four independent stages with definite time elements are available, one of the stages can also be configured to an inverse characteristic. Two stages of rate of change of voltage protection elements are also available, which can be set independently.

Residual Overvoltage

Residual overvoltage protection is available for detecting earth faults in high impedance earthed or isolated systems. The neutral voltage is derived from the 3-phase voltage inputs. Four independent measuring elements with definite time characteristics are available and one of the elements can also be configured to have an inverse characteristic.

Frequency

Nine stages each of: overfrequency, underfrequency, rate of change of frequency, frequency supervised rate of change of frequency, average rate of change of frequency, frequency based load shedding during severe system disturbances.

Broken Conductor

The broken conductor protection detects unbalanced conditions caused by broken conductors, maloperation of single phase of switchgear or by single phasing conditions. It operates on the ratio of I2 to I1.

Phase Segregated Power

Two stages of power protection are provided and each stage can be independently configured to operate as overpower or underpower and forward or reverse direction. The relays provide a standard 3-phase power protection element and also a single-phase power protection element.

Sensitive Power

Two stages of sensitive power protection are provided and these can be independently selected as reverse power, overpower, low forward power or disabled depending on the operating conditions.

Load Encroachment

Load encroachment (load blinder), an impedance based feature avoids tripping for heavy load flows.

Voltage Transformer Supervision

Voltage transformer supervision is provided to detect loss of one, two or three VT signals, providing indication and inhibition of voltage dependent protection elements. An optically isolated input may also be configured to initiate the voltage transformer supervision alarm and blocking when used with MCBs or other external forms of voltage transformer supervision.

Current Transformer Supervision

Current transformer supervision is provided to detect loss of phase CT signals and inhibit the operation of current dependent protection elements.

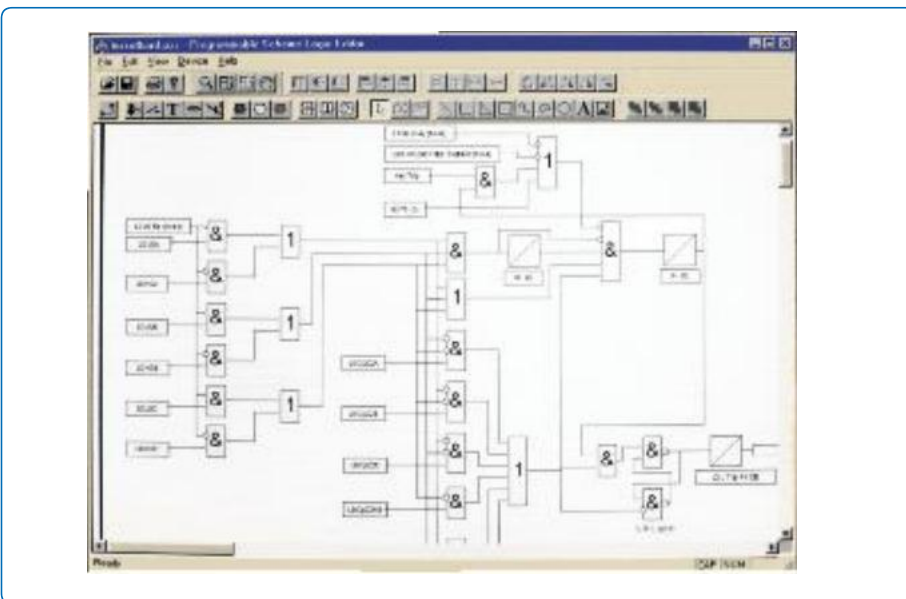

Programmable scheme logic editor (S1 Agile) offers intuitive drag-and-drop logic customising

Programmable Scheme Logic

Programmable scheme logic allows the user to customise the protection and control functions. The programmable scheme logic comprises gate logic and general purpose timers. The gate logic includes OR, AND and majority gate functions, with the ability to invert the inputs and outputs and provide feedback. The programmable scheme logic is configured using the graphical S1 Agile PC-based support software.

The system is optimised (event driven) to ensure that the protection outputs are not delayed by the PSL operation. Multiple protection functions, logic and control functions may be enabled, without deterioration in performance - the platform is fully deterministic.

Single Box Solution: High impedance Busbar Protection with Integrated Buswire Supervision

High impedance busbar protection is an alternative to biased differential bus protection. In the latter case, stability for external faults is achieved by a percentage bias slope. Conversely, in high impedance schemes the stability is achieved by virtue of a deliberate high impedance (a resistor) being added into the spill current path of the CT secondary circuit. This ensures that the differential current due to any saturated CT is minimised to a level which does not cause protection zone operation.

Should a CT become open-circuited in the scheme, this poses a fire and personnel safety risk in the substation. Depending on the level of load current flowing, zone elements may also be at risk of spurious pickup. Additionally, due to the high impedance in the scheme, the buswires may experience a prolonged overvoltage, for which they may not be thermally-rated. Supervision, to detect such scenarios, is essential.

In a traditional solution, GE's MVTP relay is added, to detect open circuit scenarios by sensitive overvoltage detection. The P14x scheme now offers the advantage that in a numerical scheme, this function is now integrated in the same device as for the zone differential element, to minimise the space occupied in relay panels, optimise cost and engineering time, and offer faster commissioning. The relaying for the zone is in one box.

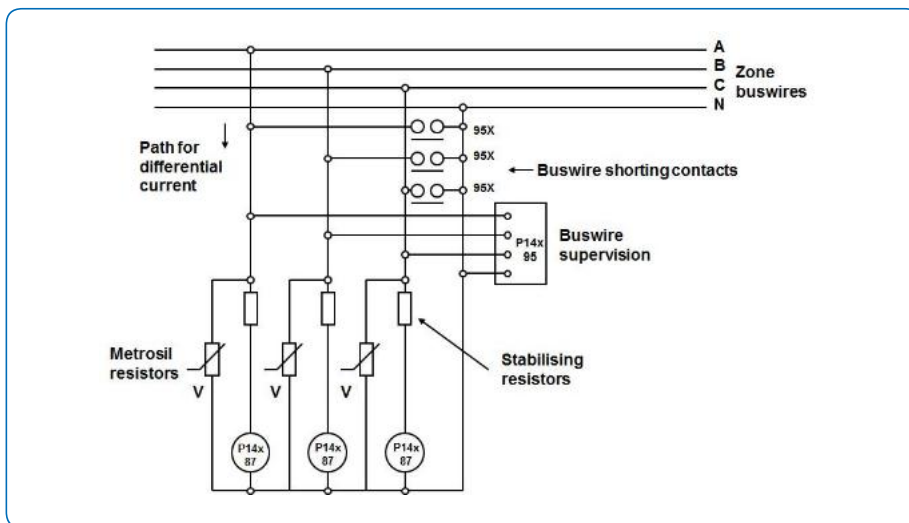

Typical high-impedance protection scheme - GE's P14x Agile relay provides full bus protection and scheme supervision

Indication (P145)

Eighteen tri-colour LEDs are available for user programming. The LED colours (red, green or yellow) are driven via digital databus signals in PSL and can be programmed to indicate up to four conditions/states, for example:

- Off -Not in service
- Red -CB closed
- Green -CB open
- Yellow -CB not healthy

Circuit Breaker Failure Protection

Two-stage circuit-breaker failure protection may be used for tripping upstream circuit-breakers and for re-tripping the local circuit-breaker if required. The circuit-breaker failure logic may also be initiated externally from other protection devices if required. The undercurrent elements used in the CB fail reset mechanism have been enhanced to detect the breaker opening in real-time, even when there are subsidence currents in the CT secondary caused by the remnant flux.

Switchgear Control

Circuit-breaker control is available from the front panel user interface, optically isolated inputs and remotely via the substation communications. 8 sets of switch control logic, LN XSWI for controlling/monitoring of disconnectors and earth switches are also available.

Autoreclose with Check Synchronising

The P142, P143 and P145 provide three-pole multi-shot autoreclose. The user may select a single, two, three or four shot autoreclose cycle, with independently settable dead times and reclaim time. Autoreclose can be initiated from the internal protection elements or from external protection via an opto input. Advanced features include live line working and sequence coordination (co-ordination with downstream reclosing equipment). The P143 and P145 also include check synchronisation.

Measurement and Recording Facilities

The P14x series is capable of measuring and storing the values of a wide range of quantities. All events, fault and disturbance records are time tagged to a resolution of 1 ms using an internal real-time clock. An optional IRIG-B port is also provided for accurate time synchronisation.

Measurements

The measurements provided, which may be viewed as primary or secondary values, can be accessed via the back-lit liquid crystal display, or the communications ports. A wide range of instantaneous and integrated parameters are available. The list includes measured signals like phase currents and voltages and computed signals like power, frequency, energy, etc. Phase currents and phase to neutral voltages are available in true rms and fundamental quantities.

Fault Location

A fault location algorithm provides distance to fault in miles, kilometres, ohms or percentage of line length.

Event Recording

Up to 512 time-tagged event records are stored in battery-backed memory and can be extracted using the communications ports or viewed on the front panel display.

Disturbance Records

The internal disturbance recorder has 8 analogue, 32 digital and 1 time channel. Approximately 50 records of 0.5 s duration can be stored. All channels and the trigger source are user configurable. Disturbance records can be extracted from the relay via the remote communications and saved in the COMTRADE format. These records may be examined using S1 Agile or any suitable software programme.

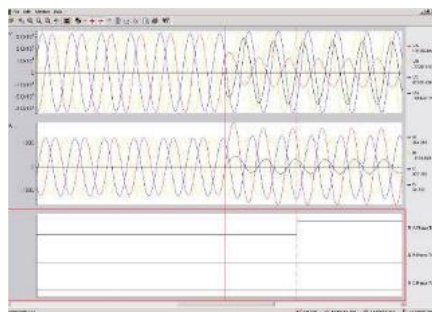

Disturbance records

Trip Circuit Supervision

Supervision of the trip circuit in both circuit-breaker open and closed states can be realised using the optically isolated inputs and programmable scheme logic.

Fault Records

Records of the last 5 faults are stored in battery-backed memory. The information provided in the fault record includes:

- Indication of faulted phase
- Protection operation
- Active setting group
- Date and time
- Fault location
- Relay and CB operating time
- Currents, voltages and frequency

Circuit Breaker Condition Monitoring

The circuit-breaker condition monitoring features include:

- Monitoring the number of breaker trip operations
- Recording the sum of the broken current quantity
- Monitoring the breaker operating time
- Fault frequency counter

Local and Remote Communications

Two communications ports are available as standard: a rear port providing remote communications and a front port providing local communications.

The front port has been designed for use with S1 Agile, which fully supports functions within the relay by providing the ability to: program the settings off-line, configure the programmable scheme logic, extract and view events, disturbance and fault records, view the measurement information dynamically and perform control functions.

The default remote communications are based on RS485 voltage levels. Any of the protocols listed below can be chosen at the time of ordering:

- Courier / K-bus
- Modbus
- IEC 60870-5-103 (optical interface also available)
- DNP 3.0
- IEC 61850 (over 100 Mbit/s, fibre/copper Ethernet)

**Industry-leading hardware reliability
with best-in-class digital inputs**

A variety of Communications Interfaces

IEC 61850 is available when the optional Ethernet port is ordered. IEC 61850 offers high-speed data exchange, peer-to-peer communications, reporting, disturbance record extraction and time synchronisation. Redundant Ethernet is also available with RSTP, PRP and HSR delivered in a single order option. The P14x has 128 virtual inputs with an improved GOOSE performance.

An optional second rear courier port is available, which may be configured as RS232, RS485 or K-Bus.

Diagnostics

Automatic tests performed, including power-on diagnostics and continuous self-monitoring, ensuring a high degree of reliability. Test features available on the user interface display input quantities and the states of the digital inputs and relay outputs.

Hardware

All models in the P14x series include:

- A back-lit liquid crystal display
- An optional IRIG-B port
- A USB port & an RS485 port
- An optional RS232/RS485/K-Bus port
- An optional Ethernet port for IEC 61850 protocol
- A download/monitor port
- N/O and N/C watchdog contacts
- 1 A/5 A dual rated CTs

Device Track Record

KCCG/KCEG - First numerical overcurrent relay launched in 1993, with over 20 000 units sold

P14x series introduced in 1999. Worldwide application, with over 200 000 units delivered

GE's P40 - Fourth generation major update in 2019

Addition of Ethernet communications hardware in 2004 through to HSR in 2015

Addition of IEC 61850 protocol in 2006 and Edition 2 in 2017

Used for the most exacting frequency protection schemes in the world

Expansion cards are available to increase the number of digital inputs and outputs for the P142, P143 and P145. Also, depending on the relay model, up to eight High Speed-High Break contacts are available as an option. This will protect against burnt contacts due to a stuck breaker or defective breaker auxiliary contact conditions.

The optically isolated inputs are independent. The digital status input thresholds are programmable. Intelligent burden switching and compliance with the ESI48-4EB2 standard provides immunity to false wiring pickup equivalent to the level offered by high burden trip relays such as MVAJ. The relay outputs may be configured as latching or self reset. All CT connections have integral shorting.

In addition to the standard -25°C to + 55°C operating temperatures claim as per IEC 60255-6, the Px40 range has proven withstand capability at extremes of temperature as per IEC 60068-2. These onerous tests were passed at -40°C and +85°C for 96 continuous hours in each case.

MiCOM P40 Agile

GE's philosophy is one of continuous improvement in our products and solutions. Our emphasis on communications in MiCOM has become a focus which secures our leadership in digital substations. To mark this phase of evolution, the brand "P40 Agile" is applied to the range. P40 Agile is a mark of performance and quality, proudly available from GE.

For more information please contact:
GE
Grid Solutions

Worldwide Contact Centre

Web: www.GEGridSolutions.com/contact
Phone: +44 (0) 1785 250 070

GEGridSolutions.com

IEC is a registered trademark of Commission Electrotechnique Internationale. IEEE is a registered trademark of the Institute of Electrical Electronics Engineers, Inc. Modbus is a registered trademark of Schneider Automation.

GE and the GE monogram are trademarks of General Electric Company.

GE reserves the right to make changes to specifications of products described at any time without notice and without obligation to notify any person of such changes.

P14x-Brochure-EN-2019-11-Grid-GA-0629. © Copyright 2019, General Electric Company. All rights reserved.



Imagination at work