

Multilin L30



Cost-Effective Current Differential System for Lines and Cables

The Multilin™ L30 Line Differential System is a cost-effective line current differential protection relay intended for sub-transmission and medium voltage lines and cables, providing reliable and secure operation even under the worst-case power system conditions. The Multilin L30 provides secure high-speed fault detection and clearance suitable for three-pole tripping applications.

Part of the Universal Relay (UR) family, the Multilin L30 comes with a variety of versatile features truly integrating protection, monitoring, metering, communication and control in one easy-to-use device.

Key Benefits

- Proven current differential protection for secure, high-speed tripping
- Increased sensitivity through dynamic charging current compensation and communication channel asymmetry compensation
- Adaptive restraint characteristic provides security against measurement errors including CT saturation
- Embedded Synchrophasor measurement capabilities (per IEEE® C37.118), eliminating the need for dedicated PMUs and support for synchrophasor multi-cast (per IEC® 61850-90-5) reducing bandwidth and communications infrastructure costs
- An integrated large, full color display, provides real-time visualization and control of the protected bay, via a bay mimic as well as annunciator functionality and graphical visualization of phasors
- Advanced IEC 61850 Ed. 1 and Ed. 2 certified implementation, complete settings via SCL files and comprehensive process bus support (IEC 61850-9-2LE or IEC 61869 or IEC 61850-9-2 Hardfiber) ensures interoperability, device managing optimization and reduced cost of ownership
- Routable GOOSE (R-GOOSE) enables customer to send GOOSE messages beyond the substation, which enables WAPC and more cost effective communication architectures for wide area applications
- Supports IEEE C37.111-1999/2013, IEC 60255-24 Ed 2.0 COMTRADE standard

Applications

- Overhead lines and underground cables of different voltage levels
- Circuits with tapped transformer feeders
- Suitable for three-terminal lines, with channel redundancy and Direct Transfer Tripping (DTT)
- Wide area system monitoring and control using integrated protection and synchrophasor measurement
- Applications requiring three-pole autoreclosing and independent synchrocheck supervision

Protection & Control

- Line current differential with adaptive restraint, in-zone transformer & Stub bus protection
- Breaker failure and three-pole autoreclose
- Phase & negative sequence directional overcurrent, neutral directional with dual polarity criteria
- Phase over/under voltage, negative sequence overvoltage and 4 independent synchronism check elements
- Protection and control functionality in one box, reducing the number of devices
- High density inputs/outputs to support the control of many switchyard assets – all from one powerful device
- Integrated large, full color display, for real-time visualization and control of the protected bay

Advanced Communications

- 3 independent Ethernet ports for simultaneous & dedicated network connection with IEEE 1588 support
- Direct I/O for secure, high-speed exchange of data between Multilin L30s for DTT applications
- Advanced Communications™ section, bullet #3:
- IEC 61850-9-2LE/IEC 61869 networked or IEC61850-9-2 Hardfiber process bus support

Cyber Security

- CyberSentry™ provides high-end cyber security aligned to industry standards and services (NERC® CIP, AAA, Radius, RBAC, Syslog)

Monitoring & Metering

- Advanced recording capabilities with high-capacity event recorder, configurable and extended waveform capture and data logger
- P & M class synchrophasors of voltage, current, and sequence components



Protection and Control

The Multilin L30 offers a high degree of modularity in its design and functionality, providing superior performance while meeting the toughest requirements of the marketplace. Advanced protection and control features of this relay includes:

Current Differential Protection

The L30 current differential protection relay uses superior and patented algorithms to address the challenges of bandwidth, security, dependability and sensitivity in current differential relaying.

Bandwidth requirements are effectively addressed by means of a patented new data consolidation technique called "phaselets". This permits application within a communications bandwidth of 64 Kbps, and can detect faults within a half cycle plus channel delay.

L30 - Protection, Metering, Monitoring and Control

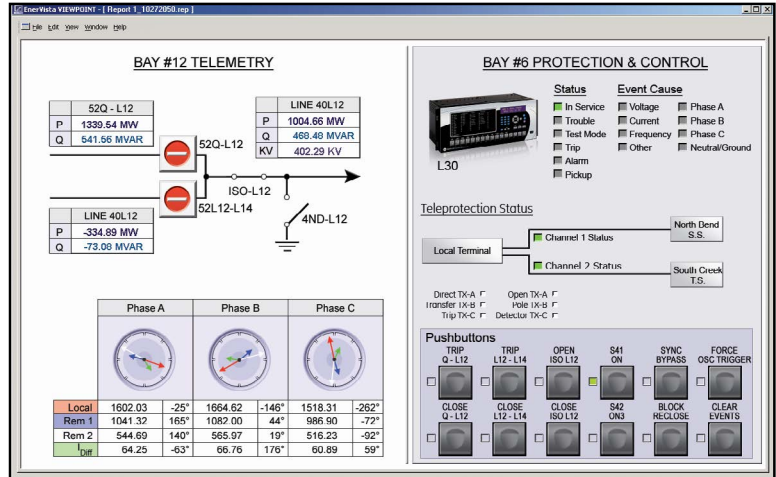

The L30 is the single point for protection, control, metering, and monitoring in one integrated device that can easily be connected directly into DCS or SCADA monitoring and control systems like Viewpoint Monitoring as shown.

Functional Block Diagram

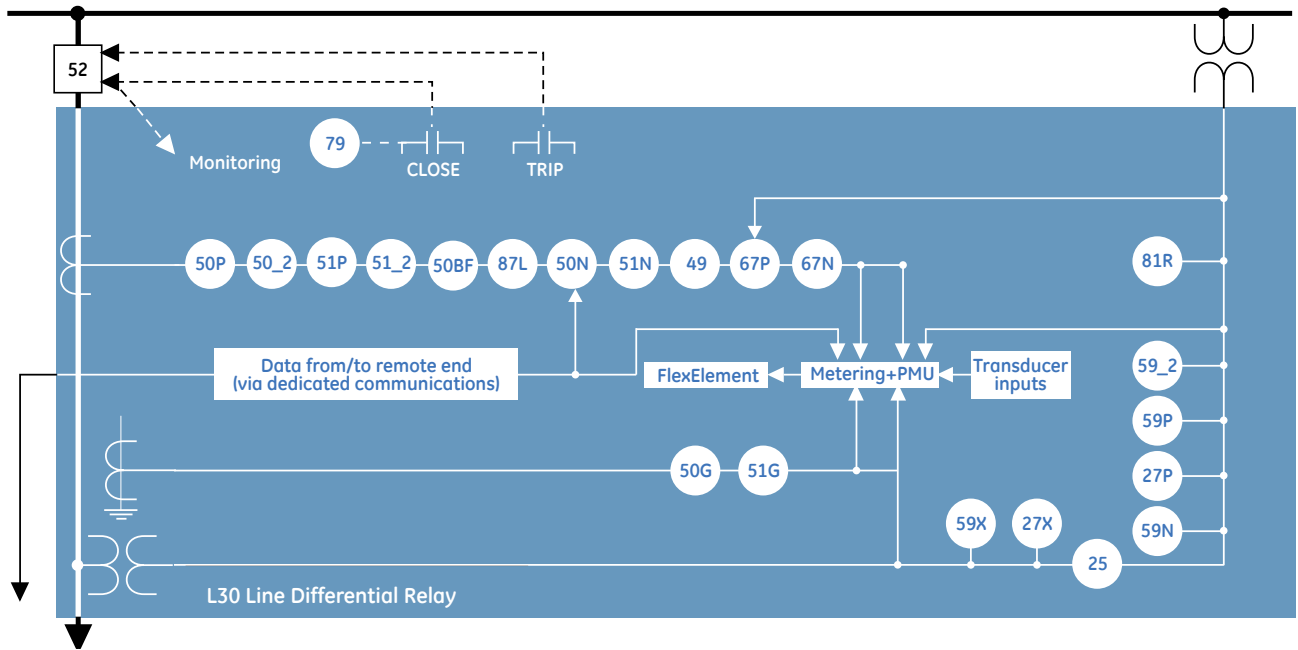

ANSI® Device Numbers & Functions

DEVICE NUMBER	FUNCTION
25	Synchrocheck
27P	Phase undervoltage
27X	Auxiliary undervoltage
49	Thermal overload protection
50BF	Breaker failure
50DD	Current disturbance detector
50G	Ground instantaneous overcurrent
50N	Neutral instantaneous overcurrent
50P	Phase instantaneous overcurrent

DEVICE NUMBER	FUNCTION
50_2	Negative-sequence instantaneous overcurrent
51G	Ground time overcurrent
51N	Neutral time overcurrent
51P	Phase time overcurrent
51_2	Negative-sequence time overcurrent
52	AC circuit breaker
59N	Neutral overvoltage
59P	Phase overvoltage
59_2	Negative-sequence overvoltage

DEVICE NUMBER	FUNCTION
59X	Auxiliary overvoltage
67N	Neutral directional overcurrent
67P	Phase directional overcurrent
79	Automatic recloser
81R	Rate of change frequency
81U	Underfrequency
87L	Segregated line current differential
87LG	Line ground current differential

The L30 innovative dual slope adaptive restraint characteristic, based on estimates of measurement errors, allows the relay to be secure on severe external faults while maintaining sensitivity for internal faults. The estimate of errors in the input currents permits more sensitive settings than those used in the traditional percent differential schemes. The line differential element also has 2nd inrush-current inhibit for in-zone power transformer protection. This functionality enables the L30 to protect 2 or 3-terminal lines that have a power transformer in between ends.

The L30 approach to clock synchronization relies upon precise distributed synchronization. Clocks are phase synchronized to each other and frequency synchronized to the power system frequency. Each relay compares its clock to the phase of the other clocks and makes appropriate adjustments. This allows for greater transient ride-through for power system and communications disturbances. Enhanced additional security is provided by a sensitive current disturbance detector, which can be used to supervise the current differential element.

Charging Current Compensation

For long lines and especially for underground cables, the charging current may be large and result in excessively high pickup settings. The L30 can dynamically compensate the charging current, thus increasing its sensitivity to the fault current on long transmission lines.

Enhanced Monitoring Features

The L30 uses advanced error detection and supervising functions to secure the L30 against maloperation due to erroneous data. High bit error rates are addressed by means of computing a 32-bit CRC checksum, effectively addressing the concerns of multiple bit errors due to high channel noise.

On multiplexed channels, channel asymmetry may be expected due to path switching causing spurious differential currents, which can endanger the security of the differential system. By using GPS time synchronization, up to 10ms of channel asymmetry can be compensated. Extra security has been implemented in the L30 to ensure proper operation in the event of IIRIG-B signal failure.

Integrated channel monitoring provides real-time diagnostic data on the health of the L30. Communications channel deterioration or failure will activate an alarm, and can be used to enable backup protection. Channel propagation delay is monitored and adjusted according to variations in communication paths.

Communication Topologies

Relays can communicate through direct fiber, RS422, G.703, and IEEE C37.94 interfaces at 64Kbps, with extensive channel monitoring and diagnostics. In a current differential scheme, the L30s exchange data via the communication link, acting either as master collecting data, making calculations and making all relevant trip and restraint decisions, or as slave only, transmitting current data to the one acting as master. For two-terminal applications, use the redundant communications capability of the L30 for optimal reliability of the current differential line protection. For this scheme, data is continuously transmitted over both channels, so if a failure occurs, the L30 will continue to provide current differential protection.

For three-terminal applications, advanced inter-relay communication features eliminate the need for redundant communication channels due to the ability of the L30 to automatically switch between master and slave mode, maintaining a dependable system even with a failure of one of the communication channels.

Overvoltage and Undervoltage Protection

Long lines under lightly loaded or no-load conditions may experience voltages exceeding rated per unit voltage level of the line. Use the three phase overvoltage elements of the L30 to initiate a local trip as well as a remote trip using Direct Transfer Tripping (DTT).

Overcurrent Functions

The L30 provides thermal overload, and time and instantaneous overcurrent elements for phase, neutral, ground, negative sequence, phase and neutral directional. The neutral directional overcurrent element supports enhanced dual polarization modes which can be configured to prioritize on voltage or current polarization. Any of them can run in parallel with primary differential protection or can be programmed to run when the differential element is not available.

Harmonic/Inrush detection

The Harmonic detection element monitors the selected 2nd to 5th harmonic or Total Harmonics Distortion (THD), which is present in the phase currents.

During transformer energization or motor starts, the inrush current present in phase currents can impact some sensitive elements, such as negative sequence overcurrent. Therefore, the ratio of the second harmonic to the fundamental magnitude per phase is monitored, while exceeding the settable pickup level, an operand is asserted, which can be used to block such sensitive elements.

Direct Transfer Trip (DTT)

Use the DTT feature of L30 to trip remote breakers. Both single and three-pole DTTs are supported. Up to eight signals can be sent over pilot communications channels, selectable through user-configurable logic.

Typical Applications

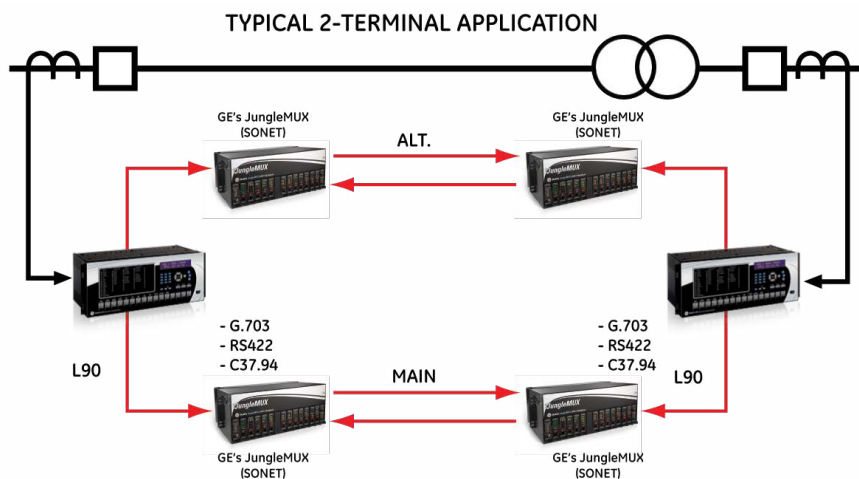

Typical two-terminal application of L30. L30 supports a variety of media cards for signaling between L30's including direct multimode or singlemode fiber, RS422, G.703 and IEEE C37.94.

Autoreclosing

The L30 provides multi-shot autoreclosing for three-pole applications with independently programmable dead time for each shot. Autoreclose can be dynamically blocked by user-programmable logic.

Synchronism Check

The L30 provides six synchrocheck elements that monitor voltage difference, phase angle difference and slip frequency taking the CB closing time into account to ensure proper breaker closure as per user requirements. The L30 provides additional enhancements in synchronizing, by checking dead source conditions for synchronism bypass under these conditions.

Breaker Failure

The L30 provides two fully independent breaker failure protection elements.

IEC 61869 and 61850-9-2LE Process Bus

Three UR process bus modules enable communicating to Merging Units “MU” that comply to either IEC 61869 standard or IEC 61850-9-2LE technical report. MUs connect to the primary asset and translate analog signals and digital status/commands to standard sample values “SV” data and GOOSE messages.

Flexibility for connecting to different network size and topology is granted through 100Mbps and/or 1Gbps Ethernet port support, plus IEC 62439 PRP or HSR standard redundancy, plus Star, Ring and Point-to-point network support.

For time synchronization purposes, this Process bus module can become an IEEE 1588 slave clock (61850-9-3 profile) or a 1588 Grand Master clock which removes the need of external time sources connected to the process bus network.

Customers who may not be using GE MU devices, could use MU from other vendors. Interoperability with MU from other vendors is expected when they comply to the mentioned standards.

IEC 61850-9-2 HardFiber Process Bus

The IEC 61850 Process Bus module is designed to interface with the GE Multilin HardFiber System, allowing bi-directional IEC 61850 fiber optic communications. The HardFiber System is designed to integrate seamlessly with existing UR applications, including protection functions, FlexLogic™, metering and communications.

FlexLogic Designer

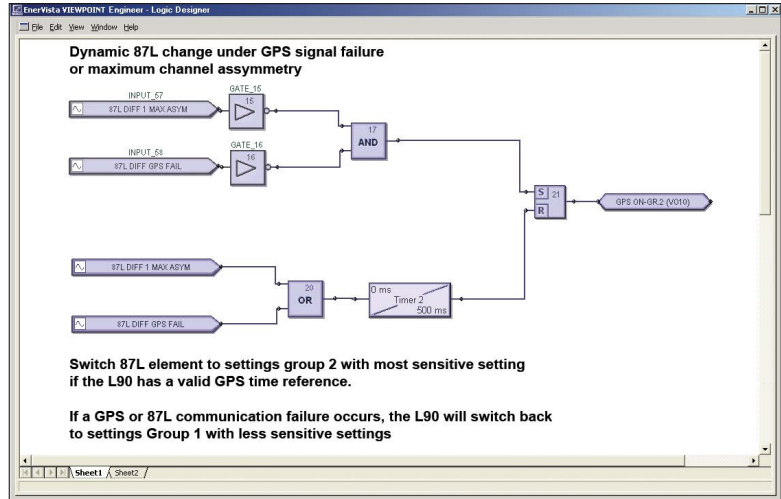

FlexLogic allows for the customization of the L30 to operate and control the breakers and other auxiliary devices needed to fit most line protection schemes and applications.

Topologies:

PRP Start
Hot-Stanby



Station Bus



Integrated Station and Process bus (available)

Topologies:

HSR ring
PRP start
P-2-P Process Bus



Process Bus:
IEC61850-9-2LE or 61869* SV
IEEE 1588 Grand Master or slave
61850-9-1 GOOSE

Merging units

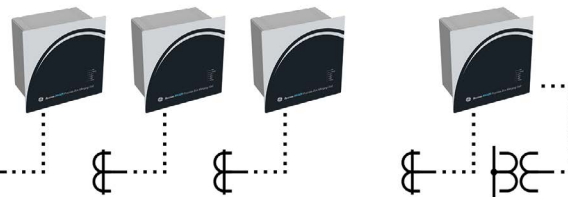

Conventional or Optical CT/VTs

The GE Multilin HardFiber System offers the following benefits:

- Communicates using open standard IEC 61850 messaging
- Drastically reduces P&C design, installation and testing labor by eliminating individual copper terminations
- Integrates with existing L30's by replacing traditional CT/VT inputs with the IEC 61850 Process Bus module
- Does not introduce new cyber security concerns

Visit the HardFiber System product page on the GE Multilin web site for more details.

Advanced Automation

The L30 incorporates advanced automation features including powerful FlexLogic programmable logic, communication, and SCADA capabilities that far surpass what is found in the average line relay. The L30 integrates seamlessly with other UR relays for complete system protection.

FlexLogic

FlexLogic is the powerful UR-platform programming logic engine that provides the ability to create customized protection and control schemes, minimizing the need and associated costs of, auxiliary components and wiring. With 1024 lines of FlexLogic, the L30 can be programmed to provide the required tripping logic along with custom scheme logic for line breaker control and interlocking and dynamic setting group changes.

Scalable Hardware

The L30 is available with a multitude of I/O configurations to suit the most demanding application needs. The expandable modular design allows for easy configuration and future upgrades.

- Flexible, modular high density I/O covering a broad range of input signals and tripping schemes
- Mechanically latching outputs can be used to develop secure interlocking applications and replace electromechanical lockout relays

Monitoring and Metering

The L30 includes high accuracy metering and recording for all AC signals. Voltage, current, and power metering are built into the relay as a standard feature. Current and

voltage parameters are available as total RMS magnitude, and as fundamental frequency magnitude and angle.

Fault and Disturbance Recording

The advanced disturbance and event recording features within the L30 can significantly reduce the time needed for postmortem analysis of power system events and the creation of regulatory reports. Recording functions include:

- Sequence of Event (SOE)
 - 1024 time stamped events
- Oscillography
 - Supports IEEE C37.111-1999/2013, IEC 60255-24 Ed 2.0 COMTRADE standard
 - 128 digital & up to 56 analog channels
 - Events with up to 45s length
- Data Logger and Disturbance Recording
 - 16 channels up to 1 sample/cycle/channel
- Fault Reports
 - Powerful summary report of pre-fault and fault values

The very high sampling rate and large amount of storage space available for data recording in the L30 can eliminate the need for installing costly stand-alone recording equipment.

Advanced Device Health Diagnostics

The L30 performs comprehensive device health diagnostic tests at startup and continuously during run-time to test its own major functions

and critical hardware. These diagnostic tests monitor for conditions that could impact security and availability of protection, and present device status via SCADA communications and front panel display. Providing continuous monitoring and early detection of possible issues help improve system uptime.

- Comprehensive device health diagnostic performed at startup
- Monitors the CT/VT input circuitry to validate the integrity of all signals

Cyber Security – CyberSentry UR

CyberSentry™ is a software option that delivers wide range of cyber security features that help customers to comply with NERC CIP, NIST® IR 7628, IEC 62351 and IEC 62443 cyber security requirements and standards. Additionally secure FW upgrade is granted through UR Setup's digital signature validation capabilities.

This software option delivers the following core features:

AAA Server Support (Radius/LDAP)

Enables integration with centrally managed authentication and accounting of all user activities and uses modern industry best practices and standards that meet and exceed NERC CIP requirements for authentication and password management.

Power System Troubleshooting

The L30 contains many tools and reports that simplify and reduce the amount of time required for troubleshooting power system events.

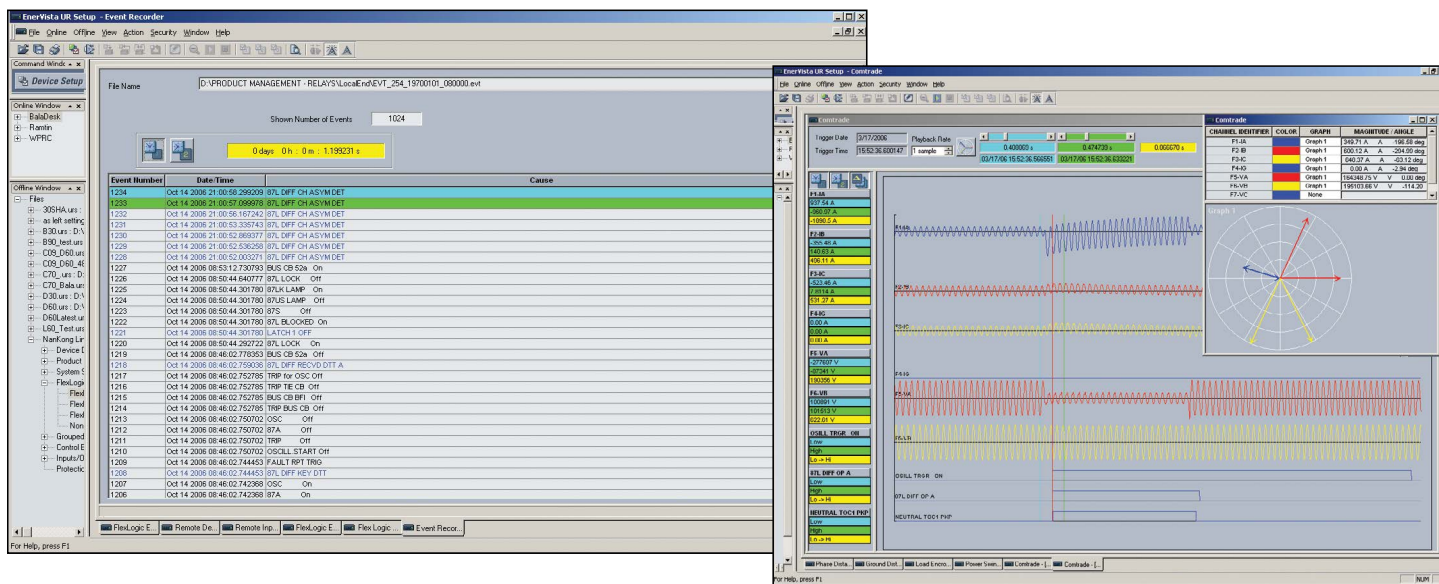

Record the operation of the internal L30 elements and external connected devices with 1ms time-stamped accuracy to identify the Sequence of Operation of station devices during line faults and disturbances.

Analyze line faults using both analog and digital power system quantities that are measured and recorded up to a rate of 64 samples per cycle.

Role Based Access Control (RBAC)

Efficiently administrate users and roles within UR devices. The new and advanced access functions allow users to configure up to five roles for up to eight configurable users with independent passwords. The standard "Remote Authentication Dial In User Service" (Radius) is used for authentication.

Event Recorder (Syslog for SEM)

Capture all cyber security related events within a SOE element (login, logout, invalid password attempts, remote/local access, user in session, settings change, FW update, etc), and then serve and classify data by security level using standard Syslog data format. This will enable integration with established SEM (Security Event Management) systems.

Communications

The L30 provides for secure remote data and engineering access, making it easy and flexible to use and integrate into new and existing infrastructures. Fiber optic Ethernet provides high-bandwidth communications allowing for low-latency controls and high-speed file transfers of relay fault and event record information. The available three independent Ethernet ports, redundant Ethernet option and the embedded managed Ethernet switch provide the means to create fault tolerant communication architectures in an easy, cost-effective manner. The L30 supports the most popular industry standard protocols enabling easy, direct integration into monitoring and SCADA systems.

- IEC 61850 Ed. 1 and Ed. 2 Station Bus, IEC 61850-2-2LE / IEC 61869 networked or IEC 61850-9-2 HardFiber Process Bus, and IEC 61850-90-5 PMU over GOOSE support
- DNP 3.0 (serial & TCP/IP)
- Ethernet Global Data (EGD)
- IEC 60870-5-103 and IEC 60870-5-104
- Modbus RTU, Modbus TCP/IP
- HTTP, TFTP, SFTP and MMS file transfer
- IEEE1588 and redundant SNTP for time synchronization
- PRP as per IEC 62439-3
- IEC61850 GOOSE, Routable GOOSE and legacy UCA fixed GOOSE

Interoperability with Embedded IEC 61850 Ed. 1 and Ed. 2

The new IEC 61850 implementation in the UR Family positions GE as an industry leader in this standard.

- Implements, user selectable, Ed. 1 and Ed. 2 of the standard across the entire UR Family
- Provides full relay setting management via standard SCL files (ICD, CID and IID)
- Enables automated relay setting management using 3rd party tools through standard file transfer services (MMS and SFTP)
- Increases the number of Logical Devices and data mapped to them, GOOSE messages from up to 64 remote devices, and reports to support different organizational needs for data transfer and reduce dependency on generic logical nodes
- Configures GE Systems based on IEC 61850 using universal 3rd party tools
- Multicast IEEE C37.118 synchrophasor data between PMU and PDC devices using IEC 91850-90-5
- R-GOOSE enable customer to send GOOSE messages beyond the substation, which enables WAPC and more cost effective communication architectures for wide area applications

LAN Redundancy

Substation LAN redundancy has been traditionally accomplished by reconfiguring the active network topology in case of failure. Regardless of the type of LAN architecture (tree, mesh, etc), reconfiguring the active LAN requires time to switchover, during which the LAN is unavailable. UR devices deliver redundancy as specified by PRP-IEC 62439-3, which eliminates the dependency on LAN reconfiguration and the associated switchover time. The UR becomes a dual attached node that transmits data packets over both main and redundant networks simultaneously, so in case of failure, one of the data packets will reach the receiving device with no time delay.

Multi-Language

UR devices support multiple languages: English, French, Russian, Chinese, Turkish, German, Polish and Japanese. These language options are available on the front panel, in the EnerVista setup software, and in the product manuals. Easily switch between English and an additional language on the local displays without uploading new firmware.

EnerVista Software

The EnerVista suite is an industry-leading set of software programs that simplifies every aspect of using the L30 relay. The EnerVista suite provides all the tools to monitor the status of the protected asset, maintain the relay, and

integrate information measured by the L30 into DCS or SCADA monitoring systems. Convenient COMTRADE and SOE viewers are an integral part of the UR setup software included with every UR relay, to carry out postmortem event analysis and ensure proper protection system operation. UR Setup also provides an export/import setting file tool which allows customer to transfer specific settings from one file to another. This tool also provides comprehensive setting file comparison. These features, together with UR single setting file, help users to simplify their setting file management experience.

EnerVista Launchpad

EnerVista Launchpad is a powerful software package that provides users with all of the setup and support tools needed for configuring and maintaining GE Multilin products. The setup software within Launchpad allows for the configuration of devices in real-time by communicating using serial, Ethernet, or modem connections, or offline by creating setting files to be sent to devices at a later time.

Included in Launchpad is a document archiving and management system that ensures critical documentation is up-to-date and available when needed. Documents made available include:

- Manuals
- Application Notes
- Guideform Specifications
- Brochures
- Wiring Diagrams
- FAQ's
- Service Bulletins

Viewpoint Monitoring

Viewpoint Monitoring is a simple-to-use and full-featured monitoring and data recording software package for small systems. Viewpoint Monitoring provides a complete HMI package with the following functionality:

- Plug-&-Play Device Monitoring
- System Single-Line Monitoring & Control
- Annunciator Alarm Screens
- Trending Reports
- Automatic Event Retrieval
- Automatic Waveform Retrieval

Ordering

Base Unit	L30	-	* 00	-H	*	* -F	** -H	** -L	** -N	** -S	** -U	** -W/X	** **	For Full Sized Horizontal Mount	
Base Unit	L30													Base Unit RS485 + three multimode SFP LC 100BaseFX RS485 + two multimode SFP LC 100BaseFX + one SFP RJ45 100BaseT. RS485 + three SFP RJ45 100BaseT RS485 + two 100BaseFx Eth, Multimode ST + one 10/100BaseT Eth, RJ-45 ¹ No Software Options IEC 61850 Phasor Measurement Unit (PMU) IEC 61850 + Phasor Measurement Unit (PMU) 3P Autoreclose, Synchrocheck and IEC61850 3P Autoreclose, Synchrocheck, IEC61850 and Phase Measurement Unit (PMU) In-zone TX protection In-zone TX protection + IEC 61850 In-zone TX protection + PMU In-zone TX protection + IEC 61850 + PMU CyberSentry UR Lvl 1 IEEE 1588 PRP IEEE 1588 + CyberSentry IEC 61850 + PMU + 61850-90-5 Horizontal (19" rack) - Standard Horizontal (19" rack) - Harsh Environment Coating Vertical (3/4 size) - Standard Vertical (3/4 size) - Harsh Environment Coating	
Software Options ¹			T U V W												
Mount / Coating				H A V B											
User Interface					E A C D R B P G S U V L M N I J Q T W Y H O X Z									7" Graphical display, USB front port & programmable pushbuttons - Multi-Language (FW 7.6x or higher) Chinese English French Russian Chinese with Additional 4 Small and 12 Large Programmable Pushbuttons English with Additional 4 Small and 12 Large Programmable Pushbuttons French with Additional 4 Small and 12 Large Programmable Pushbuttons Russian with Additional 4 Small and 12 Large Programmable Pushbuttons Enhanced Chinese Front Panel Enhanced Chinese Front Panel with User-Programmable Pushbuttons Enhanced English Front Panel Enhanced English Front Panel with User-Programmable Pushbuttons Enhanced French Front Panel Enhanced French Front Panel with User-Programmable Pushbuttons Enhanced German Front Panel Enhanced German Front Panel with User-Programmable Pushbuttons Enhanced Russian Front Panel Enhanced Russian Front Panel with User-Programmable Pushbuttons Enhanced Turkish Front Panel Enhanced Turkish Front Panel with User-Programmable Pushbuttons Enhanced Polish Front Panel ³ Enhanced Polish Front Panel with User-Programmable Pushbuttons ³ Enhanced Japanese Front Panel ³ Enhanced Japanese Front Panel with User-Programmable Pushbuttons ³	
NOTE: These selections are only for horizontal units															
Power Supply ²				H L								RH		125 / 250 V AC/DC 24 - 48 V (DC only) 125 / 250 V AC/DC with redundant 125/250 V AC/DC Standard 4CT/4VT with enhanced diagnostics Standard 8CT with enhanced diagnostics 8 Port IEC 61850 Process Bus Module -9-2LE & 61869 Process Bus, 2 x 100BaseF -9-2LE & 61869 Process Bus, 4 x 100BaseF + 4 x 100BaseFx -9-2LE & 61869 Process Bus, 4 x 100BaseFx	
CT/VT DSP						8L 8N									
IEC 61850 Process Bus ^{4,5}							81 85 86 87								
Digital I/O								XX 4A 4C 4D 4L 67 6C 6D 6E 6F 6K 6L 6M 6N 6P 6R 6S 6T 6U 6V 6W 6X	XX 4A 4C 4D 4L 67 6C 6D 6E 6F 6K 6L 6M 6N 6P 6R 6S 6T 6U 6V 6W 6X	XX 4A 4C 4D 4L 67 6C 6D 6E 6F 6K 6L 6M 6N 6P 6R 6S 6T 6U 6V 6W 6X	XX 4A 4C 4D 4L 67 6C 6D 6E 6F 6K 6L 6M 6N 6P 6R 6S 6T 6U 6V 6W 6X	XX 4A 4C 4D 4L 67 6C 6D 6E 6F 6K 6L 6M 6N 6P 6R 6S 6T 6U 6V 6W 6X	No Module 4 Solid State (No Monitoring) MOSFET Outputs 4 Solid State (Current w/opt Voltage) MOSFET Outputs 16 Digital Inputs with Auto-Burnish 14 Form-A (No Monitoring) Latchable Outputs 8 Form-A (No Monitoring) Outputs 8 Form-C Outputs 16 Digital Inputs 4 Form-C Outputs, 8 Digital Inputs 8 Fast Form-C Outputs 4 Form-C & 4 Fast Form-C Outputs 2 Form-A (Current w/ opt Voltage) & 2 Form-C Outputs, 8 Digital Inputs 2 Form-A (Current w/ opt Voltage) & 4 Form-C Outputs, 4 Digital Inputs 4 Form-A (Current w/ opt Voltage) Outputs, 8 Digital Inputs 6 Form-A (Current w/ opt Voltage) Outputs, 4 Digital Inputs 2 Form-A (No Monitoring) & 2 Form-C Outputs, 8 Digital Inputs 2 Form-A (No Monitoring) & 4 Form-C Outputs, 4 Digital Inputs 4 Form-A (No Monitoring) Outputs, 8 Digital Inputs 6 Form-A (No Monitoring) Outputs, 4 Digital Inputs 2 Form-A (Cur w/ opt Volt) 1 Form-C Output, 2 Latching Outputs, 8 Digital Inputs 30 Contact Inputs - Pin Terminals ³ 18 Form-A (No Monitoring) Outputs - Pin Terminals ³		
Transducer I/O							5A 5C 5D 5E 5F	5A 5C 5D 5E 5F	5A 5C 5D 5E 5F	5A 5C 5D 5E 5F	5A 5C 5D 5E 5F	5A 5C 5D 5E 5F	5A 5C 5D 5E 5F	4 dcmA Inputs, 4 dcmA Outputs 8 RTD Inputs 4 RTD Inputs, 4 dcmA Outputs 4 dcmA inputs, 4 RTD Inputs 8 dcmA Inputs	
Select a maximum of 3															
Inter-Relay Communications															
Select a maximum of 1														2A 2A 2B 2B 2I 2I 2J 2J 7B 7B 7H 7H 7I 7I 7S 7S 7W 7W 72 72 73 73 76 76 77 77	C37.94SM, 1300nm singlemode, ELED, 1 Channel singlemode C37.94SM, 1300nm singlemode, ELED, 2 Channel singlemode Channel 1 - IEEE C37.94, 820nm, multimode fiber, 64/128 kbps; Channel 2 - 1300 nm, singlemode, LASER Channel 1 - IEEE C37.94, 820nm, multimode fiber, 64/128 kbps; Channel 2 - 1550 nm, singlemode, LASER 1300 nm, multimode, LED, 1 Channel 820 nm, multimode, LED, 2 Channels 1300 nm, multimode, LED, 2 Channels G.703, 2 Channels RS422, 2 Channels 1550 nm, singlemode, LASER, 1 Channel 1550 nm, singlemode, LASER, 2 Channels IEEE C37.94, 820 nm, multimode, LED, 1 Channel IEEE C37.94, 820 nm, multimode, LED, 2 Channel

Ordering Note:

- To view all the options available for L30, please visit GE's Online Store <http://store.gedigitalenergy.com/viewprod.asp?model=L30>
- Redundant power supply only available in horizontal unit. If redundant chosen, must be same type. Maximum 2 per chassis.
- Option available soon
- Process bus module requires empty slots next to it.
- Conventional DSP and Process Bus modules cannot run simultaneously

IEC is a registered trademark of Commission Electrotechnique Internationale. IEEE is a registered trademark of the Institute of Electrical Electronics Engineers, Inc. Modbus is a registered trademark of Schneider Automation. NERC is a registered trademark of North American Electric Reliability Council. NIST is a registered trademark of the National Institute of Standards and Technology.

GE, the GE monogram, Multilin, FlexLogic, EnerVista and CyberSentry are trademarks of General Electric Company. GE reserves the right to make changes to specifications of products described at any time without notice and without obligation to notify any person of such changes.

Copyright 2023, General Electric Company. All Rights Reserved.

GEA-12759P(EN)
English
230417

