



# MRTP

## Supervision for AC Pilot Circuits

The MRTP is a monitoring device for the supervision of AC pilot circuits. The MRTP type relay as shown in Figure 1, provides supervision for AC circuits such as pilot wires interconnecting protective relays. It provides indication should the pilot wires become open or short circuited, reverse connected or in the event of insulation deterioration.

Figure 2 (page 3) shows the arrangement for supervision of pilots insulated for 5 kV. It requires the pilot circuit to be terminated by a resistor or other element that will provide a path for the DC supervision current. Figure 3 (page 3) shows a similar arrangement for pilot circuits insulated for 15 kV. The injection filters are then assembled as part of the isolation transformers and have to be isolated from the supervision module. The isolation transformer provides the necessary 15 kV isolation barrier.

The supervision circuit MRTP, as shown in Figure 2, requires a low voltage AC supply which is connected to terminals 27 and 28.

The input transformer can be provided with a primary winding to suit the available supply. The secondary voltage is converted to a clipped sine wave of constant amplitude by a zener diode connected in a bridge rectifier circuit.

The DC voltage developed across the zener diode is used to power the measuring circuit which in turn measures the current flowing into the injection filter. The clipped sine wave voltage is rectified in the injection filter and a capacitor is charged to the peak value to produce a constant level DC voltage.

A capacitor connected in the pilot circuit between terminals 17 and 18 by-passes the AC pilot current and directs a DC current from the supervision circuit around the pilot circuit. To enable crossed pilots to be detected and ensure correct indication for pilots which become short circuited at the remote end, it is necessary to include a second injection filter in the pilot circuit as shown for the remote line end. This filter ensures that remote short circuits eliminate sufficient resistance in the pilot loop to cause a detectable current change.

A change in the DC supervision current is indicative of a pilot fault and causes a corresponding change in the AC current supplied by the supervision relay. The measuring circuit monitors this AC current and initiates a PILOT FAILURE alarm, after a time delay, if a sufficient change takes place.

The AC supervision supply is also monitored and, in the event of a failure, a time delayed SUPPLY FAILURE alarm is initiated.

## Key Benefits

- Alarm and indication of open circuit, cross connected and short circuit pilots
- Alarm and indication of supervision supply failure
- Suitable for pilot circuits insulated to 5 kV or 15 kV when used with external transformer
- Separate indication of short circuit and open circuit pilots

## Models Available

- MRTP 01 Pilot supervision with injection filter
- MRTP 02 Injection filter
- MRTP 03 Pilot Supervision

Figure 1. MRTP relay withdrawn from case

## Technical Data

### Ratings

AC Supervision Voltage		DC Auxiliary Voltage	
Rated voltage (Vn)	Operating range (V)	Rated voltage (Vx)	Operating range (V)
110	88-127	24/27	19.0- 33.0
127	102-146	30/34	24.0- 41.0
220	176-253	48/54	24.0- 41.0
240	192-276	110/125	24.0- 41.0

### Frequency

50 or 60 Hz

### Burdens

Burden at rated voltage

#### DC Burden

(Vx)	Quiescent	2 LEDs operated	Output operated
24/27	0.2 W	1.5 W	3 W
30/34	0.5 W	1.5 W	6 W
48/54	0.5 W	1.7 W	6 W
110/125	1 W	3 W	6 W

#### AC Burden

5.3 VA at any rated voltage setting

### Settings

#### Range of pilot loop resistance

0-10,000 ohms  
A variable resistance accessible from the front of the relay, allows the calibration to be changed to suit the pilot circuit resistance.

#### Supply failure alarm Time delay for alarm

below 70% Vn approx.  
6-10s

### Contacts

2 changeover on the pilot fail element  
2 changeover on the supply fail element

### Contact Rating

#### Make/Carry for 0.2 s Carry continuously Make/Carry for 1.5 s / Break

7500 VA subject to maxima of 30 A and 300 V AC or DC (ANSI C37.90)  
5 A AC or DC  
AC – 1250 VA  
DC – 50 W resistive  
25 W, L/R = 0.04 s  
subject to maxima of 5 A and 300 V  
10,000 operation minimum

### Indications

Non-volatile red led trip indicators are used for supply fail, pilot fail short circuit and pilot fail open circuit. If the auxiliary supply is lost the led will return to the same state when the supply is restored. A green led is used to give an instantaneous indication of pilot fault to assist commissioning the relay.

### High Voltage Withstand

Dielectric withstand IEC 60255-5: 2005  
5 kV rms for 1 minute between pilot wire circuit (terminals 17, 18, 19, 20) and all other circuits including case earth.  
2 kV rms for 1 minute between all terminals and case earth.  
2 kV rms for 1 minute between terminals of independent circuits including contact circuits, with terminals on each independent circuit connected together.  
1 kV rms for 1 minute across open contacts of output relays.

### High Voltage Impulse IEC 60255-27: 2005

5 kV peak, 1.2/50 μs, 0.5 J between all terminals and case earth and between independent circuits and case earth and between independent circuits.

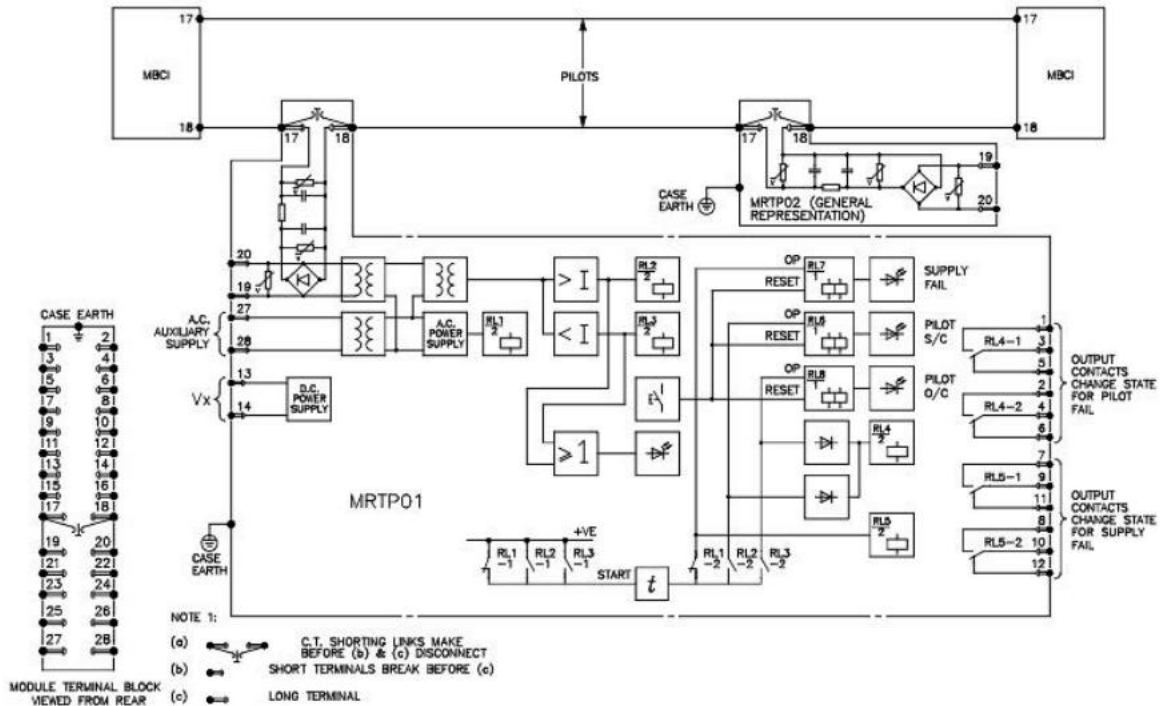

Figure 3: Application diagram: pilot supervision relay type MRTP 03 (15 kV isolation)

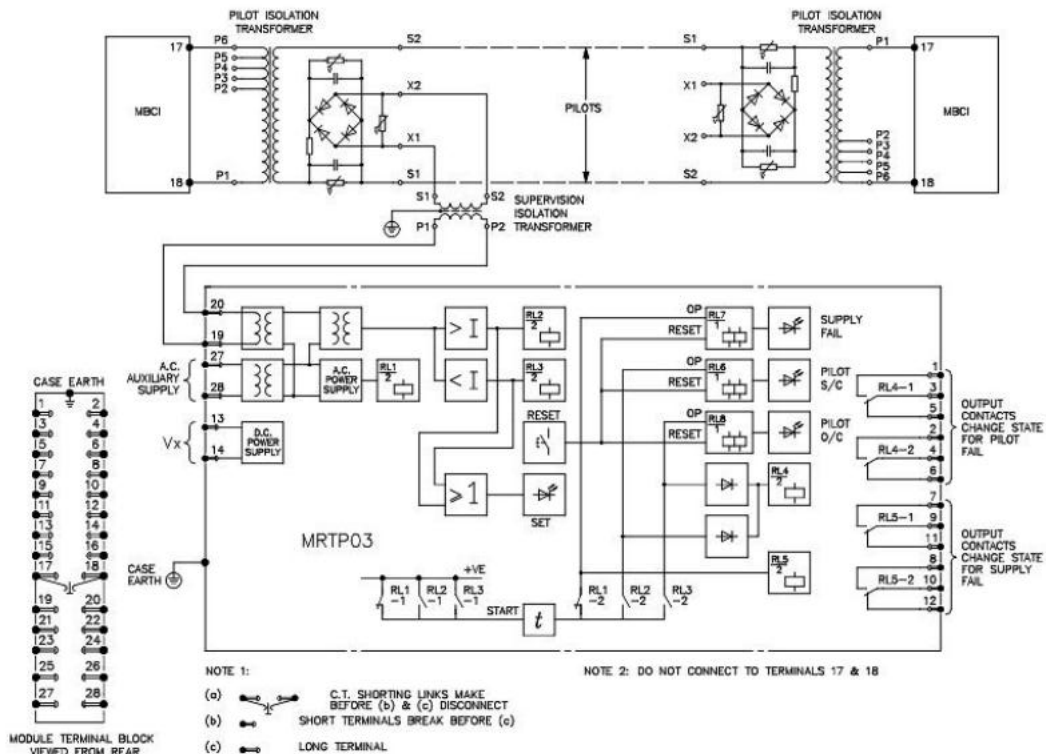

Figure 2: Application diagram: pilot supervision/injection filter type MRTP 01 (5 kV insulation)

## Electrical Environment

### High Frequency Disturbance

#### IEC 60255-22-1: 2007 Class III

- 2.5 kV peak between independent circuits and case
- 1.0 kV peak across terminals of the same circuit
- No additional tolerances are required for the operating time or the unit's thresholds

#### Electrostatic Discharge IEC 60255-22-2: 2008 Class IV

- 15.0 kV discharge in air with cover in place
- 8.0 kV point contact discharge with cover removed
- No additional tolerances are required for the operating time or the unit's thresholds

#### Fast Transient Disturbance IEC 60255-22-4: 2008 Class IV

- $\pm 4.0$  kV 5 kHz and 100 kHz applied to all inputs / outputs excluding communication ports
- $\pm 2.0$  kV 5 kHz and 100 kHz applied to all communication ports
- No additional tolerances are required for the operating time or the unit's thresholds

EMC Compliance  
2004/108/EC  
EN 60255-26: 2009

Compliance to the European Commission Directive on EMC is claimed via the Technical Construction File route. Product specific standards were used to establish conformity.

PRODUCT SAFETY  
2006/95/EC



Compliance with the European Commission Low Voltage Directive

IEC 60255-27: 2005

Compliance is demonstrated by reference to product specific safety standards  
Equipment has Class 1 protection against electric shock and is designed for use in a Pollution Degree 2 environment.

For more information please contact  
GE  
Grid Solutions

### Worldwide Contact Center

Web: [www.GEGridSolutions.com/contact](http://www.GEGridSolutions.com/contact)  
Phone: +44 (0) 1785 250 070

## Atmospheric Environment

### Temperature

IEC 60255-1: 2009	Storage and transit $-25^{\circ}\text{C}$ to $+70^{\circ}\text{C}$
IEC 60068-2-1: 2007	Operating $-25^{\circ}\text{C}$ to $+55^{\circ}\text{C}$
IEC 60068-2-2: 2007	Cold Dry heat

### Humidity

IEC 60068-2-78: 2001	56 days at 93% RH and $40^{\circ}\text{C}$
----------------------	--

### Enclosure protection

IEC 60529: 2001	IP50 (dust protected)
-----------------	-----------------------

### Mechanical environment vibration

IEC 60255-21-1: 1988	Response Class 2 Endurance Class 2
----------------------	---------------------------------------

## Information Required with Order

### Type of relay

- Pilot supervision with injection filter MRTP 01 (5 kV circuits)
- Injection filter MRTP 02 (5 kV circuits)
- Pilot supervision MRTP 03 (15 kV circuits)
- Pilot isolation transformer with injection filter HN0068001 (15 kV circuits)
- Supervision isolation transformer ZC0243003 (15 kV circuits)

AC Voltage rating

DC Voltage rating

### Additional Information

Associated publications

R6001 MIDOS System

R6004 MMLG/MMLB/Test plug/block

R6011 MBCI Translay 'S' differential feeder protection

## GEGridSolutions.com

IEC is a registered trademark of Commission Electrotechnique Internationale. IEEE is a registered trademark of the Institute of Electrical Electronics Engineers, Inc.

GE and the GE monogram are trademarks of General Electric Company.

GE reserves the right to make changes to specifications of products described at any time without notice and without obligation to notify any person of such changes.

MRTP-Brochure-EN-2018-11-Grid-GA-0730. © Copyright 2018, General Electric Company. All rights reserved.



Imagination at work