



# MM2

## MOTOR PROTECTION SYSTEM

Integrated process, control, and protection for low voltage motors

### KEY BENEFITS

- Full featured protection for low voltage AC motors
- Advanced automation capabilities providing customized protection and integrated automation control
- Cost effective solution - Low cost modular design
- Small footprint and compact design - With or without display, fits into standard MCC buckets
- Preconfigured logic for all standard motor starter types, EnerVista™ compatible
- Integrated motor control pushbuttons
- Remote monitoring via serial communications, Modbus RTU
- Easy installation and integration - Panel mount option
- Reduced number of devices - Replaces bi-metal overload elements, integrates timers, relays, meters, switches, indicators

### APPLICATIONS

- Motor protection and management system for low voltage AC motors
- Specifically designed for Motor Control Centre applications

### FEATURES

#### Protection and Control

- Motor Thermal Model
- Single phase / Current unbalance
- Contactor failure
- Locked/stalled rotor
- Ground fault
- Undervoltage, Overvoltage
- Overtemperature
- Acceleration Trip
- Thermistor Protection
- Starts per Hour / Time Between Starts
- Undercurrent and underpower
- Configurable motor start controller
- Undervoltage auto restart

#### Monitoring and Metering

- Motor operational parameters and historical data
- Process data
- Phase and ground current, power, energy, voltage
- Status of relay inputs
- Trip record and pre-trip values
- Motor statistical information

#### User Interface

- 40 Character LCD display
- Front Panel control push buttons and programming keypad
- 11 Motor and Relay Status LED's
- RS485 ModBus™ , 1200 - 19,200 bps

#### EnerVista™ Software

- State of the art software for configuration and commissioning GE Multilin products
- Document and software archiving toolset to ensure reference material and device utilities are up-to-date
- EnerVista™ Integrator providing easy integration of data in the MM2 into new or existing monitoring and control systems

## Protection and Control

The MM2 is a digital motor protection system designed to protect and manage low voltage motors and driven equipment. It contains a full range of selectively enabled, self contained protection and control elements as detailed in the Functional Block Diagram and Features table.

### Thermal Overload

An overload trip occurs when the thermal capacity value equals 100%. Thermal capacity used is calculated from accumulated  $I^2t$  value and chosen overload curves. True RMS current sensing ensures correct response to the heating effect of harmonics. One of 12 different  $I^2t$  time overcurrent overload curves may be selected from eight standard curves and four NEMA compatible curves.

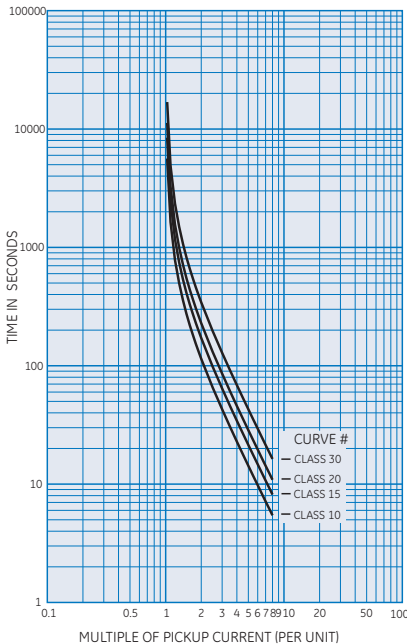

NEMA compatible time/current overload curves.

### Phase Unbalance

The MM2 monitors the percentage unbalance in the motor phase currents. If a phase current unbalance of greater than 15% exists for more than five seconds an alarm is generated. If a phase current unbalance of greater than 30% exists for more than five seconds a single phase trip occurs.

### Locked/Stalled Rotor

To help prevent damage to mechanical equipment such as pumps or fans, the MM2 will trip when the running current exceeds the stalled rotor trip level after the programmed time delay. This feature may be set to 'OFF' if desired, and it is disabled during motor starting.

### Ground Fault

The ground fault level is measured as a percentage of the CT primary. Ground overcurrent can be detected either from the residual connection of the phase CTs or from a zero sequence CT. A delay time is set to prevent false alarms from momentary surges. Both a ground fault alarm and trip are provided. The alarm can be set below the trip level to provide an early warning of insulation breakdown.

### Overtemperature

An input from motor winding thermistors is available. The MM2 can accept both positive temperature coefficient (PTC) and negative temperature coefficient (NTC) sensors. A thermistor level can be selected for both alarm and trip.

### Cooling Time

After an overload trip, the thermal capacity value decreases exponentially to model the motor cooling characteristic.

An overload trip can be reset when the thermal capacity value decreases to 15%. A stopped motor cooling time can be set to determine how long it takes for a stopped motor to reach steady state ambient temperature from its maximum allowable temperature.

### Undercurrent/Underpower

Both undercurrent and underpower alarms and trips are provided with time delays. Protection against failed shear pin or loss of pump flow, which may result in only a small change in current, is provided by the underpower alarm.

### Undervoltage

For voltage sensitive loads, a drop in voltage increases the drawn current, which may cause overheating in the motor. The undervoltage protection feature can be used to either cause a trip or generate an alarm when the voltage drops below a specified voltage setting for a programmable time delay.

### Overvoltage

An overvoltage on running motor with a constant load results in decreased current. However, iron and copper losses increase, causing an increase in motor temperature. The current overload relay will not pickup this condition and provide adequate

## Functional Block Diagram

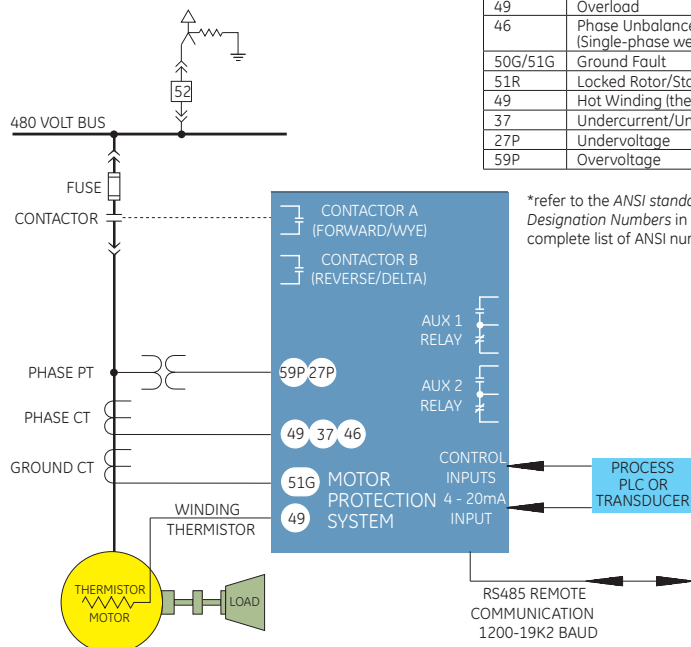

### ANSI Device Numbers & Functions

Device Number	Function
49	Overload
46	Phase Unbalance (Single-phase welded/open contactor)
50G/51G	Ground Fault
51R	Locked Rotor/Stalled Rotor
49	Hot Winding (thermistor)
37	Undercurrent/Underpower
27P	Undervoltage
59P	Overvoltage

\*refer to the ANSI standard Device Designation Numbers in the catalog for a complete list of ANSI numbers

protection. The overvoltage element may be used for protecting the motor in the event of a sustained overvoltage condition.

### Contactor Failure

The MM2 monitors the contactor while performing start and stop commands. If the contactor does not change status as an 'open control circuit' or 'welded contactor' alarm is triggered.

### Additional Alarms

The MM2 has programmable alarms to warn of a number of abnormal conditions. These include: acceleration time exceeded, abnormal inverter starter, incomplete start, motor greasing, contactor inspection, motor stop time, analog input, and process interlock switch open.

### Starters

MM2 can be programmed to serve as the following types of motor starters:

- Full Voltage non-reversing,
- Full Voltage reversing,
- Wye/Delta open or close transition starter,
- Two speed starter,
- Inverter (VSD) starter,
- Slip ring (rotor resistors) and primary resistance starters,
- Autotransformer open or close transition starter,
- Duty/Standby starter,
- Soft starter

### Undervoltage Auto Restart

The motor can be automatically restarted after a momentary power loss when this feature is enabled. When the control voltage drops below the dropout voltage the contactors are de-energized. The MM2 can initiate timers to restart selected drives upon the return of supply voltage. If control voltage is restored within the programmed restart time, the motor will be restarted immediately. If the control voltage takes longer to be restored, the MM2 can be programmed to attempt a restart after a programmed time delay.

### Outputs

The MM2 has one or two contactors (A and B) which are used for motor starting. There are also two auxiliary programmable output relays available on the MM2, which can be assigned to any one of 31 functions.

### Switched Inputs

The MM2 has up to six fixed control inputs. These are used for start A and B, stop, local isolator, and contactor A and B status. The MM2 also has up to 10 programmable switch inputs. Each input can have one of 33 interlock functions assigned to it. A function can be assigned to one interlock input only.

### Analog Input

The analog input can be scaled to user defined values. High and low alarm and trip setpoints are recorded with time delays.

### Monitoring and Metering

The MM2 offers advanced monitoring and metering which includes:

#### Metering

The MM2 meters and displays:

- current of each phase
- Ground fault leakage current
- Motor load as a % of full load current
- Thermal capacity used (%)
- % Current unbalance
- Power (kW)
- Energy (kWh)
- Voltage
- Analog input

#### Trip Record

When the MM2 issues a trip command a record is generated which includes the cause and pre-trip actual values.

#### Statistics and Maintenance

The MM2 records statistical data about relay and motor operation, allowing the user to set the interval at which routine maintenance tasks should be performed. When the times are exceeded an alarm is generated. These include:

- Motor greasing interval: number of hours between bearing lubrication
- Contactor inspection: number of starts after which the contactor contacts must be inspected for wear

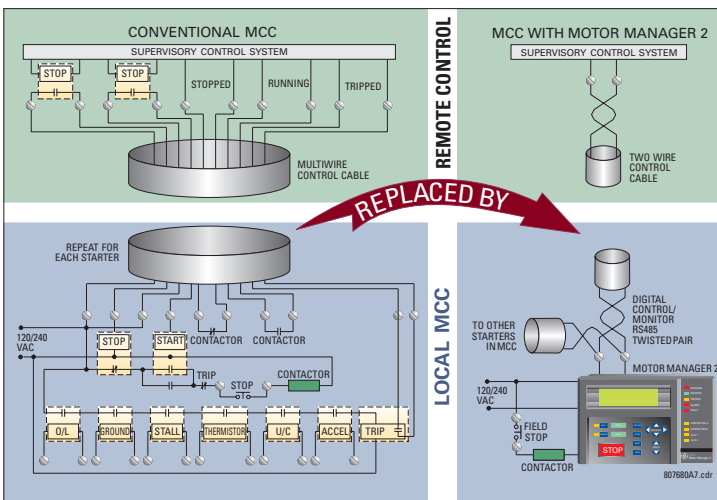

Cost Effective MCC Wiring with MM2.



One MM2 is typically mounted in each starter of a motor control center.

- Maximum motor stopped time: the maximum number of hours the motor can be left shut down

## User Interfaces

When ordered with the Panel Mount option, the MM2 comes equipped with a 40 character display, LED indicators, as well programming and control push buttons.

### Display and Keypad

The MM2 has a keypad and 40 character display for local control and programming without a computer. In the event of a trip, alarm, or start block, the display will automatically display a clear status message.

In addition to the programming keys, the panel mount option also provides 3 control keys for starting and stopping the motor locally.

### Indicator LEDs

The panel mount MM2 has nine LED's that provide the status of the motor and relay output contacts. Two additional LED's indicate whether the relay is in Auto or Manual control mode.

### Communications

The MM2 uses a ModBus® RTU RS485 connection for communication. Up to 32 MM2s can be daisy-chained together on a single communication channel. The MM2 supports a number of baud rates, ranging from at 1200 to 19,200 bps. A RS232/485 converter module may be used to connect a personal computer to the MM2.

### Software

The MM2 comes with a Windows®-based configuration program called MM2PC. It allows access to all the features of the MM2 with easy to use, pull-down menus. Using this program it is possible to:

- Program or modify setpoints
- Load or save setpoints from or to a disk
- Read actual values from the MM2
- Monitor status
- Read pre-trip data and trip record
- Display dynamic trending of actual values
- Get help on any topic

- Print the instruction manual from disk

### Mounting Configurations

The MM2 can be ordered as either a chassis mount or panel mount relay.

The chassis mount comes with all of the standard features and may be ordered with one or both of the option packages. Setpoints are loaded through the RS485 port using the MM2 PC Setup program.



*The chassis mount model is mounted inside the motor control center (MCC).*

The panel The MM2 Panel Mount (PD) option is available when both of the option packages have been ordered. The panel mount MM2 is mounted through the front panel of the MCC, providing complete local programming and control.



*The MM2 Panel Mount (PD) option*

### Option Packages

Option package 1 increases the control and diagnostic features available. It includes:

- Process control and process inputs
- Undervoltage auto restart
- Enhanced diagnostics including alarms, pre-trip data, and historical statistics about the use and performance of the motor and drive

Option package 2 increases the protection features and input options. It includes:

- Second contactor control, including two more control inputs
- Single-phase VT input used to calculate

and display the kW and kWh absorbed by the drive

- Enhanced protection including five more protection features
- Motor winding thermistor input

## EnerVista™ Software

The EnerVista™ Suite is an industry leading set of software programs that will simplify every aspect of using the MM2 relay. Tools to monitor the status of your motor, maintain your relay, and integrate information measured by the MM2 into HMI or SCADA monitoring systems are available.

### EnerVista™ Launchpad

EnerVista™ Launchpad is a powerful software package that provides users with all of the setup and support tools needed for configuring and maintaining GE Multilin products. Launchpad allows configuring devices in real-time by communicating using serial, Ethernet, or modem connections, or offline by creating setting files to be sent to devices at a later time. Included in Launchpad is a document archiving and management system that ensures critical documentation is up-to-date and available when needed. Documents made available include:

- Manuals
- Application Notes
- Guideform Specifications
- Brochures
- Wiring Diagrams
- FAQ's
- Service Bulletins

### Viewpoint Monitoring

Viewpoint Monitoring is a powerful yet simple-to-use monitoring and data recording package for small systems. Viewpoint Monitoring provides a complete HMI package with the following functionality:

- Plug-&-Play Device Monitoring
- Single-Line Monitoring & Control
- Annunciator Alarming
- Trending Reports



## Features

### Front View

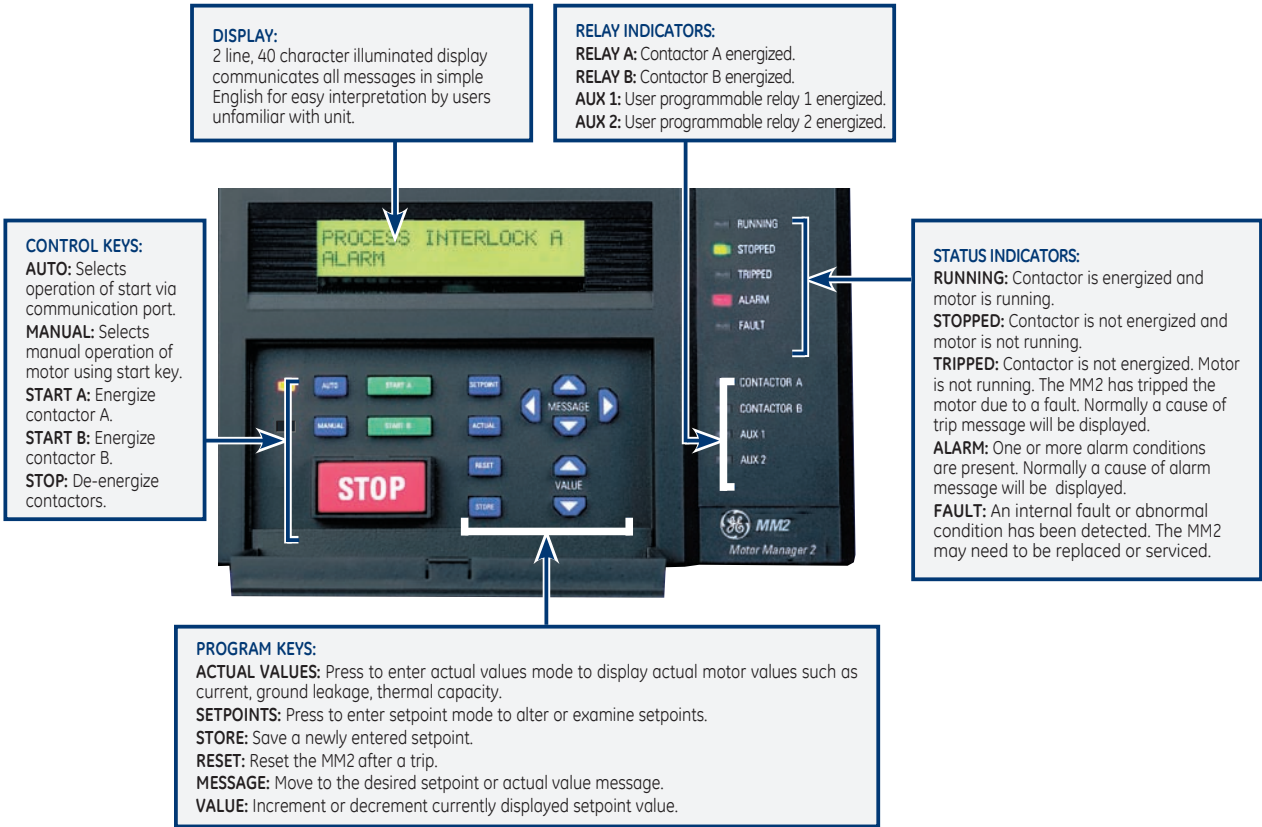

### Rear View

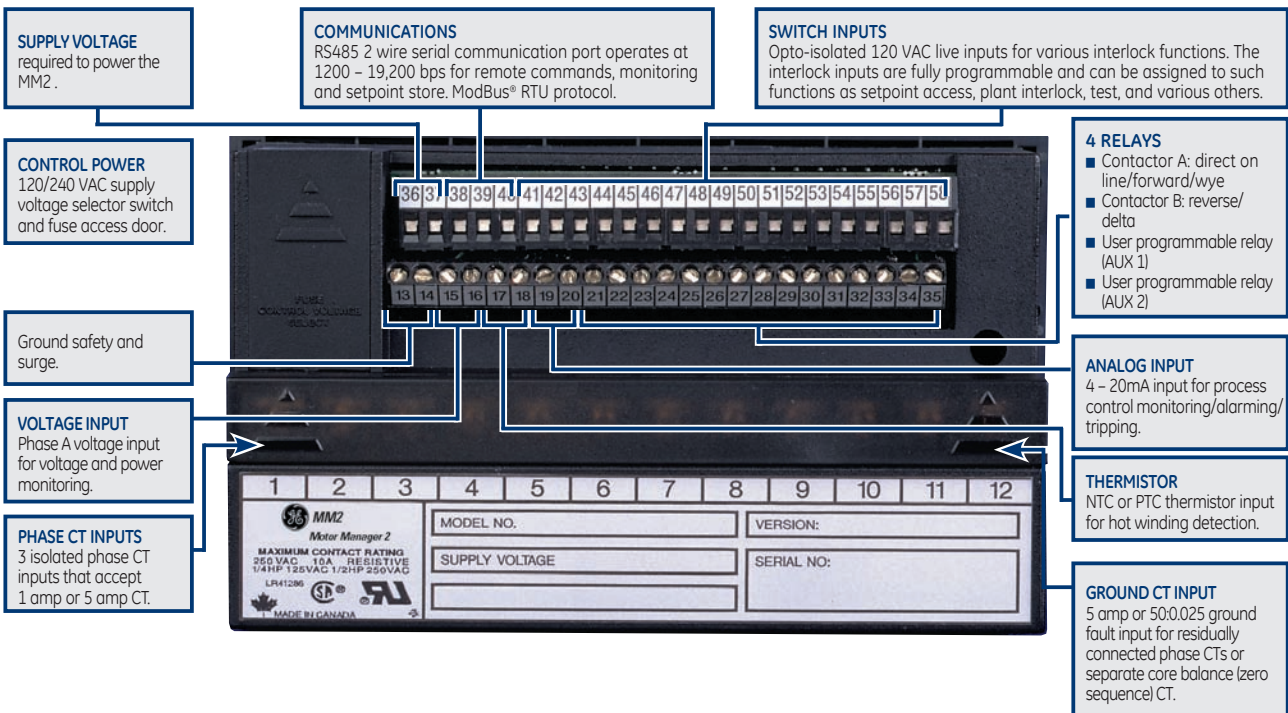

# Typical Wiring

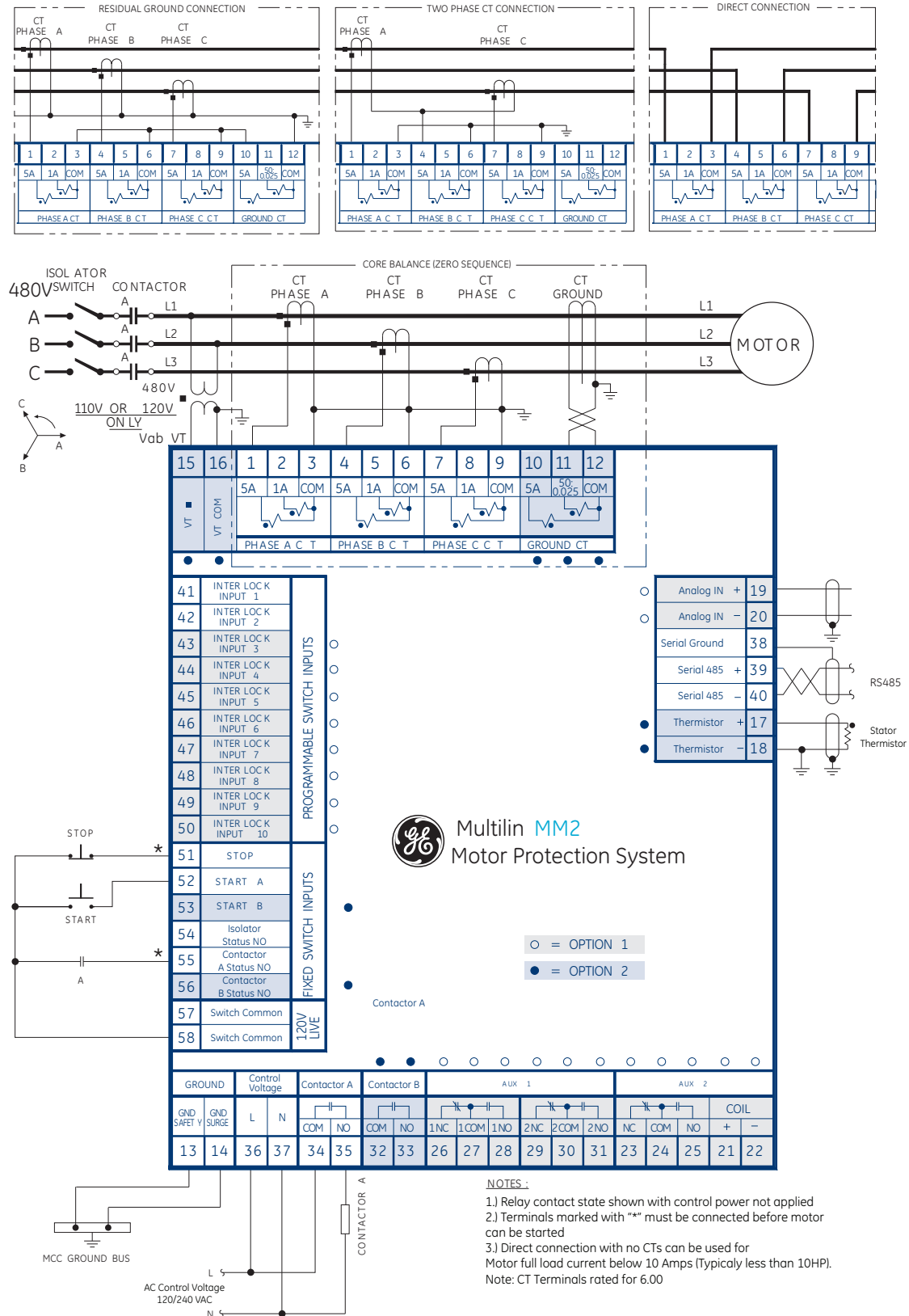

# Technical Specifications

## PROTECTION

**OVERLOAD CURVES**  
**Trip time accuracy:** ±200 ms up to 10 sec  
 ±2% of trip time over 10 sec  
 ±1% of primary CT amps

**Directional level:** ±1% of primary CT amps  
**GROUND FAULT TRIP TIME**  
**Accuracy:** -0 ms/+50 ms  
 When time delay set to 0.00 s, expect a time delay between 0 and 50 ms

**SINGLE PHASE (PHASE UNBALANCE)**  
**Range:** Greater than 30% U/B trip, alarm 15%  
 ±2 percentage points  
**Accuracy:** ±2 percentage points  
**Trip delay:** 5 sec, ±1 sec  
**Calculation method:** If  $I_{AV} \geq I_{FLC} \cdot \frac{I_M - I_{AV}}{I_{FLC}} \times 100$   
 If  $I_{AV} < I_{FLC} \cdot \frac{I_M - I_{AV}}{I_{FLC}} \times 100$   
 Where:  $I_{AV}$  = average phase currents  
 $I_M$  = current in a phase with maximum deviation from  $I_{AV}$   
 $I_{FLC}$  = motor full load current setting

## UNDERCURRENT

**Range:** 10 – 100% of motor FLC, or OFF  
**Delay range:** 1 – 60 sec  
**Accuracy:** ±1 sec  
**UNDERVOLTAGE - SUPPLY VOLTAGE**  
**Undervoltage:** 65% of nominal (120 VAC or 240 VAC)  
 immediate restart for maximum dip time of 0.1 – 0.5 sec or OFF  
 delayed restart for maximum dip time of 0.1 – 10.0 sec/unlimited time

**Delay restart range:** 0.2 – 300 sec  
**Delay restart accuracy:** ±0.2 sec

## MONITORING

**VOLTAGE INPUT/POWER READING**  
**Conversion:** True RMS, sample time 1.67 ms  
**Voltage full scale:** 1.5 x VT primary  
 ±2% of VT primary or  
**Voltage accuracy:** ±2% of reading (whichever is greater)

**Power accuracy:** ±5% of nominal or  
 ±5% of reading (whichever is greater)

**Input voltage:** Nominal: 120 VAC or 110 VAC  
 Max: 150 VAC  
 0.01 VA

## VT burden:

**ACCELERATION TIME**  
**Range:** 0.5 – 125 sec, or OFF  
**Accuracy:** ±0.5 sec

**THERMAL COOLING TIMES**  
**Range:** 5 – 1080 min when motor stopped  
 50% of motor stopped value when motor running  
**Accuracy:** ±1 min

## STALLED ROTOR

**Range:** 1.15 to 4.50 x FLC, or OFF  
**Delay range:** 0.5 to 5 sec  
**Accuracy:** ±0.5 sec

## METERING

**PHASE CURRENT INPUTS**  
**Conversion:** True RMS, sample time 1.67 ms  
**Range:** 0.1 – 8 x phase CT primary amps setpoint  
**Full scale:** 8 x phase CT primary amps setpoint  
**Accuracy:** ±2% of Phase CT primary amps setpoint or  
 ±2% of reading, whichever is greater

## GROUND FAULT CURRENT INPUT

**Conversion:** True RMS, sample time 1.67 ms  
**Range:** 0.1 to 1.0 x G/F CT primary amps setpoint  
 (5 A secondary CT)  
 0.5 to 15.0 amps (50:0.025 CT)  
 1.5 x G/F CT primary amps setpoint  
 (5 A secondary CT)  
 15 A (50:0.025 CT)  
**Accuracy:** ±4% of G/F CT primary amps setpoint  
 (5 A secondary CT)  
 ±0.3 A (50:0.025) CT

## OUTPUTS

### RELAY CONTACTS

MM2 CONTACTOR A & B AND AUX 2 OUTPUT RELAY CONTACTS				
VOLTAGE	MAKE/CARRY CONTINUOUS	MAKE/CARRY 0.2 SEC	BREAK	
RESISTIVE	30 VDC 125 VDC 250 VDC	10 A 10 A 10 A	30 A 30 A 30 A	10 A 0.5 A 0.3 A
INDUCTIVE (L/R = 7ms)	30 VDC 125 VDC 250 VDC	10 A 10 A 10 A	30 A 30 A 30 A	5 A 0.25 A 0.15 A
RESISTIVE	120 VAC 250 VAC	10 A 10 A	30 A 30 A	10 A 10 A
INDUCTIVE (PF = 0.4)	120 VAC 225 VAC	10 A 10 A	30 A 30 A	10 A 8 A
CONFIGURATION	CONTACTOR A & B – FORM A AUX RELAY 2 – FORM C			
CONTACT MATERIAL	SILVER ALLOY (AgCdO)			
MAX OPERATING VOLTAGE	280 VAC, 250 VDC			
MINIMUM PERMISSIBLE LOAD	5 VDC, 100 mA			

### MM2 AUX 1 OUTPUT RELAY

VOLTAGE	MAKE/CARRY	MAKE/CARRY 0.2 SEC	BREAK	
RESISTIVE	30 VDC 125 VDC	5 A 5 A	15 A 15 A	5 A 0.25 A
INDUCTIVE (L/R = 7ms)	30 VDC 125 VDC	5 A 5 A	15 A 15 A	2.5 A 0.1 A
RESISTIVE	120 VAC 240 VAC	5 A 5 A	15 A 15 A	5 A 5 A
INDUCTIVE (PF = 0.4)	120 VAC 225 VAC	5 A 5 A	15 A 15 A	5 A 3 A
CONFIGURATION	AUX RELAY 1 – DUAL FORM C			
CONTACT MATERIAL	SILVER ALLOY (AgCdO)			
MAX OPERATING VOLTAGE	280 V AC, 125 V DC			

## INPUTS

### THERMISTOR INPUTS

**Sensor types:** positive temperature coefficient PTC  
 RHOT=100 – 30,000 negative temperature coefficient  
 NTC  
 RHOT=100 – 30,000  
 1 sec  
 ±5% or 100 (whichever is greater)

### Delay:

**Accuracy:** ±1% full scale programmable 4 – 20 mA

### ANALOG INPUT

**Range:** 4 – 20 mA  
**Accuracy:** ±1% full scale programmable 4 – 20 mA  
**Alarm:** programmable 4 – 20 mA  
**Trip:** programmable 4 – 20 mA

### CT INPUTS

	CT INPUT (A)	BURDEN	
		(VA)	(I)
Phase CT (1 A)	1	0.009	0.01
	5	0.2	0.01
	20	3.5	0.01
Phase CT (5 A)	5	0.04	0.002
	25	0.9	0.002
	100	16	0.002
Ground CT (5 A)	5	0.04	0.002
	25	1.1	0.002
	100	17	0.002
Ground CT (50:0.025)	0.025	0.07	116
	0.1	1.19	119
	0.5	30.5	122
WITHSTAND			
	1 SEC x CT	5 SEC x CT	CONTINUOUS x CT
Phase CT (1 A)	100	40	3
Phase CT (5 A)	100	40	3
Ground CT (5 A)	100	40	3
50:0.025 GROUND INPUT WITHSTAND			
Continuous	150 mA		
Maximum	12 A for 3 cycles		
50:0.025 input can be driven by a GE Multilin 50:0.025 CT			

## POWER SUPPLY

**SUPPLY VOLTAGE**  
**AC nominal:** 120 VAC, range 80 – 135 VAC  
**Frequency:** 240 VAC, range 150 – 250 VAC  
**Max continuous:** 280 VAC

## COMMUNICATION

**Type:** RS485 2 wire, half duplex  
**Baud rate:** 1,200 – 19,200 bps  
**Protocol:** ModBus® RTU  
**Functions:** Read/write setpoints, read actual values, execute commands, read coil status, read device status, loopback test

## ENVIRONMENTAL

**Pollution degree:** 2  
**Overvoltage category:** 2  
**Insulation voltage:** 300 V  
**Operating temperature range:** 0° C to 60° C

**Dust and moisture rating:** NEMA Type 12 + 12k  
**IP Class:** IEC 529-IP53

## TYPE TESTS

**CSA:** Approved file no. LR41286  
**UL:** Recognized file no. E83849  
**Transients:** ANSI/IEEE C37.90.1 oscillatory/fast risetime transients  
 IEC 801-4 electrical fast transient/burst requirements  
**Impulse:** IEC 255-5 5 kV impulse voltage test  
**RFI:** 150 MHz, 450 MHz 5 W handheld transmitter @ 25 cm  
**Static:** IEC 801-2 electrostatic discharge  
**Hipot:** 1500 V, 1 min all input >30 V

## PACKAGING

**Max weight:** 4 lbs (1.8 kg)  
**Shipping dimensions:** 8.3" x 5.625" x 5.8"  
 (211 mm x 143 mm x 147 mm)

## FUSE TYPE / RATING

0.5 A 250 V  
 Fast blow, high breaking capacity

## INSTALLATION

**WARNING:** HAZARD may result if the product is not used for its intended purpose

**Ventilation requirements:** None  
**Cleaning requirements:** None

## INSTALLATION

**CE :** Conforms to IEC 947-1, IEC 1010-1  
**CSA:** Approved file no. LR41286  
**UL:** Recognized under E83849  
**Quality assurance system:** Registered by QMI to CSA CAN3.Z299.3-1985 and ISO 9001-1994

\*Specifications subject to change without notice.

## Dimensions

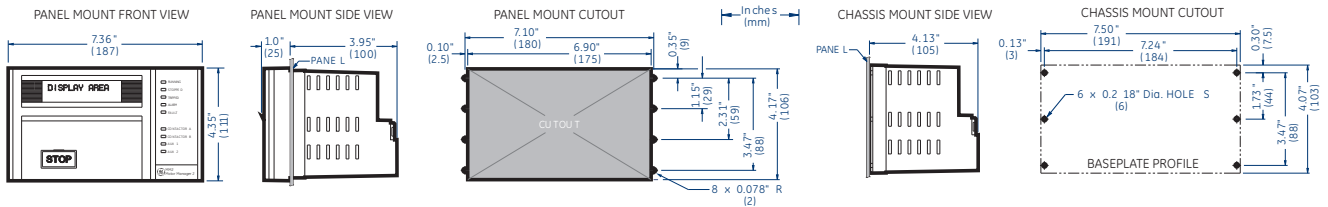

Model Table: The MM2 is available in chassis mount or a panel mount model. Both models may be enhanced with two option packages. The panel mount model with display may only be ordered with both options.

	Standard	Option 1 Adds	Option 2 Adds
<b>Protection and Control</b>	Overload (49/51) phase unbalance (46) welded/open contactor	Undervoltage auto restart diagnostics	Ground fault (50G/51G), rapid trip locked/stalled rotor (48) overtemperature thermistor (49) undercurrent/underpower (37) overvoltage (59)/undervoltage (27)
<b>Inputs</b>	4 Control 2 Programmable	8 Programmable 1 Analog	2 Control Thermistor input
<b>Relays</b>	Contactor control (A)	Auxiliary 1 and 2	Single-phase voltage input for kW and kWh Contactor control (B)
<b>Mounting Configurations</b>	Chassis mount	Chassis mount panel mount with display available when both options are ordered	Chassis mount

## Ordering

MM2	*	*	*	*	
MM2					Basic unit
	PD				Panel mount with display *
	C				Chassis mount (black box)
		1			<b>Option 1</b> Process control, 10 process inputs, undervoltage auto restart, diagnostics
			2		<b>Option 2</b> Enhanced protection, power (kW), thermistor, 2nd contactor control, and 2 process inputs
				120	Control voltage 120 VAC
				240	Control voltage 240 VAC

Note: \*Only Available when both options are ordered.

### Modifications

- MOD601: 240 VAC switch inputs – allows the use of external 240 VAC supply to power switch inputs
- MOD602: 24 – 48 VDC switch inputs – allows the use of external 24 – 48 VDC supply to power switch inputs
- MOD603: ESD relay – converts AUX 2 relay into an emergency shutdown relay
- MOD605: Removable rear terminals – allows terminals 13 – 58 to be unplugged from the MM2
- MOD610: Conformal coating
- MOD613: 240 VAC VT input
- MOD614: VT primary setpoint up to 7200 V and variable overload curve setting
- MOD615: VT primary setpoint up to 7200 V and backspin timer
- MOD616: MM2 with remote display

### Accessories for the MM2

- Viewpoint Monitoring VP-1
- 50:0.025 Ground CT HGF3
- 5 A Phase CT
- 1 A Phase CT

### Visit [www.GEMultilin.com/MM2](http://www.GEMultilin.com/MM2) to:



- View Guideform Specifications
- Download the instruction manual
- Review applications notes and support documents
- Buy an MM2 online