

Multilin™ MIF II

FEEDER PROTECTION SYSTEM

Economical feeder protection with recloser



KEY BENEFITS

- Low priced scalable options – event reports, waveform capture, reclosure
- Reduce troubleshooting and maintenance cost – Event reports, waveform capture
- Design flexibility – Easy to use programming logic
- Asset monitoring – Breaker health, and breaker failure
- Access to information – Modbus RTU communications
- Configurable logic, curves, I/Os and LEDs
- Flash memory for field upgrades
- Two settings groups
- Password protection for local operation
- Automatic display of last fault information
- AC/DC power supply
- Improved user interface
- Access via front panel keypad or communication links
- EnerVista™ compatible
- Isolated front RS232 serial port

APPLICATIONS

- Primary feeder protection on distribution networks
- Backup/auxiliary protection for transformers, generators and motors

FEATURES

Protection and Control

- Phase and ground TOC and IOC
- Thermal image protection
- IAC time-current curves
- EPTAR-C time-current curves
- Circuit breaker control (open and close)
- Four shot autorecloser
- Cold load pickup element
- Configurable breaker failure to open
- Configurable I/O
- 6 outputs: trip, service required, 4 auxiliary

Monitoring & Metering

- 32-event record
- Analog/digital oscillography
- KI² counter for breaker maintenance
- Per phase current metering
- Monitoring of the last 5 trips information from the display

User Interfaces

- EnerVista™ for setting and monitoring
- 2x16 character LCD display
- 6 LED indicators, 4 configurable in function and colour.
- Independent front RS232 and rear RS485
- Multiple Protocols - ModBus RTU, IEC 60870-5-103

EnerVista™ Software

- EnerVista™ software - an industry leading suite of software tools that simplifies every aspect of working with Multilin devices
- EnerVista™ Integrator providing easy integration of data in the MIFII into new or existing monitoring and control systems



imagination at work

Overview

The MIF II is a member of the M II Family of protection relays. This relay is used to perform primary circuit protection on distribution networks at any voltage level, and backup/auxiliary protection for transformers, generators and motors. Basic protection features include time delayed overcurrent, instantaneous overcurrent (two levels), and thermal image protection. Overcurrent elements can be three-phase and ground or single phase, depending on the selected model. An optional protection offering is also provided for cold load pickup, breaker failure protection, breaker health, configurable logic, and autorecloser.

Each protection element can be selectively enabled either via the front panel or via communications. Flexible settings, and selectable models for ANSI, IEC, IAC or EPTAR-C curves enable accurate coordination with other devices.

The basic MIF II has two fixed digital inputs and six fixed digital outputs. An option is provided allowing the two inputs and four of the outputs to be user configurable.

The basic MIF II has six fixed status LEDs. An option is provided allowing four of these LEDs to be user configurable. The front panel also features a 5-button keypad and a 16x2 LCD display that provides an easy to use user interface.

The front keypad allows the user to set the baud rate and relay address for communication.

A front RS232 and a rear RS485 communication port are provided for computer access using ModBus®RTU protocol. The rear RS485 can be converted to Ethernet by means of an external converter, such as Multilin MultiNet™.

The MIF II can be accessed with a PC using the M II EnerVista™ Setup Software via the RS232 communication port located in the relay front panel. Use EnerVista™ to view or modify settings and relay configuration (inputs, outputs, LEDs and configurable logic), as well as to display metering information, and real time status. If the relay was furnished with the appropriate option, use EnerVista™ to display last fault information such as event reports and an oscillography records.

Protection

The MIF II provides primary circuit protection for distribution feeders, and backup/auxiliary protection for transformers, generators and motors. As part of the M II Family, the MIF II provides advanced digital protection which includes:

Overcurrent Protection

A variety of time curves are provided, depending on model. It includes GE IAC, ANSI, IEC, EPTAR-C (for resistive earths), definite time and user-programmable curves. The GE-IAC curves inverse, very inverse, extremely inverse, short and

long inverse allow retrofit of popular electromechanical IAC relays.

Phase TOC

The TOC protection can be set from 0.1 to 2.4 per unit. Four standard TOC curves can be selected in addition to a user configurable curve. Each curve can be set with customized time multipliers to coordinate with equipment.

Ground TOC

This element has the same curve selection choices and settings as the phase time overcurrent element. The ground signal is normally derived as the residual sum of the three-phase CTs eliminating the need for an additional ground sensor. For more sensitive detection, an additional core balance (zero sequence) ground sensor encircling the three-phase conductors can be used.

Instantaneous Overcurrent

The MIF II includes two separately adjustable IOC elements, each of which can be independently enabled. MIF II models provide two three-phase IOC elements and two ground IOC elements. The pickup setpoint can be set from 0.1 to 30 times I_n and a time delay from 0 to 600 seconds.

Functional Block Diagram

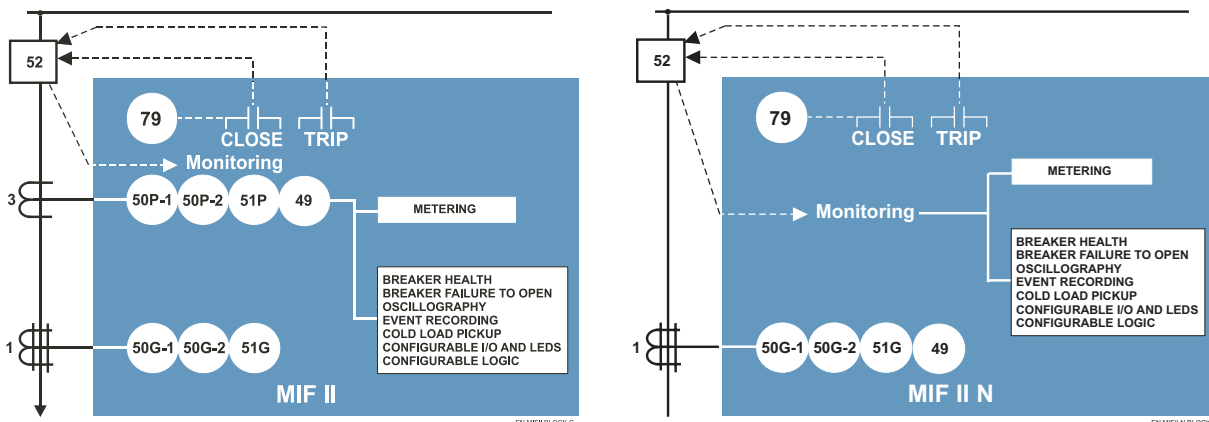

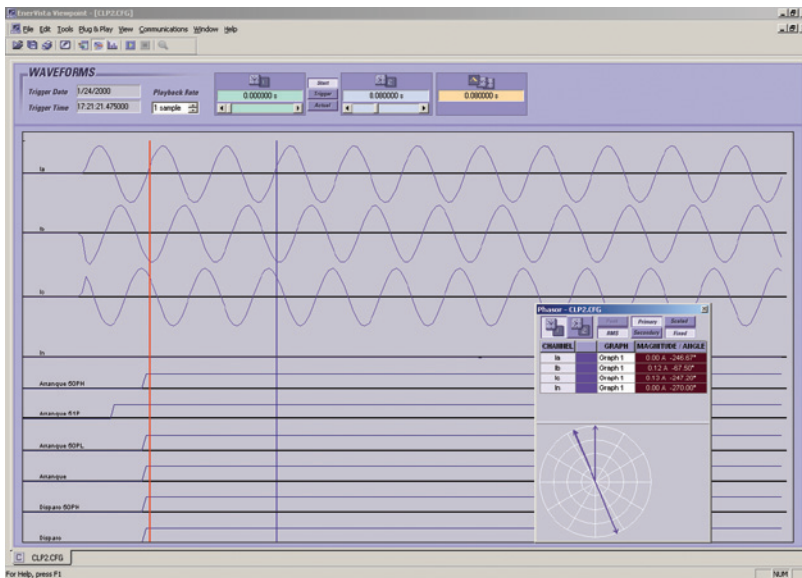

Use the oscillography feature as an accurate troubleshooting and diagnostics tool

Thermal Image Unit

A thermal image element protects equipment against overheating due to excessive load. Several operating curves can be set as a function of heating time constant T1 (adjustable between 3 and 600 minutes). Cool down time constant T2 is adjustable from one to six times the heating time constant.

Inputs and Outputs

The basic unit of MIF II incorporates two inputs programmed as Disable 50P and Disable 50G, and 6 outputs, programmed as Service Required, Trip, Phase Trip, Ground Trip, 50 Trip and 49 Alarm.

The factory configuration of MIF II inputs and outputs can be easily modified using EnerVista™ software in relays with OPTION 1 or OPTION 2.

Multiple Setting Groups

Two separate settings groups are stored in nonvolatile memory, with only one group active at a given time. Switching between setting groups 1 and 2 can be done by means of a setting, a communication command or contact input activation. Settings classified into two categories, main and advanced settings. This allows users to have access to main relay functionality in an extremely simple, user-friendly way by entering only main settings.

Access to complete functionality for more complex use is available through advanced settings.

Metering

MIF II provides metering values for phase and ground currents. The accuracy is 3% in the complete range, and 1% at the rated current.

Primary or Secondary Metering

The MIF II can monitor both the primary and secondary current metering values, by setting the corresponding CT ratio.

Option 1 Features

MIF II OPTION 1 units include all the functions described above plus the following features.

Event Recording

Events consist of a broad range of change of state occurrences, including pickups, trips, contact operations, alarms and self test status. The MIF II stores up to 32 events time tagged to the nearest millisecond. This provides the information needed to determine sequence of events which facilitates diagnosis of relay operation. Each event is individually maskable in order to avoid the generation of undesired

events, and includes the values of currents and status of all the protection elements at the moment of the event.

Oscillography

MIF II captures current waveforms and digital channels at 8 samples per cycle. One oscillography record with a maximum length of 24 cycles is stored in memory. Oscillography is triggered either by internal signals or an external contact.

Configurable I/O and LEDs

In MIF II OPTION 1 and OPTION 2 models, the two digital inputs are user configurable. Out of the six digital outputs incorporated, two have a fixed function (trip and service required), while the other four are user programmable. Those configurable outputs can be assigned either to a set of pre-configured values, or an OR/NOT combination of the same values. Each configurable output can be independently latched, and individually selected as NO or NC by means of a jumper.

Four of the 6 LED indicators can also be programmed by the user. The first LED has a fixed assignment (relay in service), the second is fixed for trip, and the remaining four LEDs are configurable in function, memory and color (red or green).

Option 2 Features

MIF II OPTION 2 units include all the functions described above plus the following features.

Cold Load Pickup

This feature adapts the pickup of the overcurrent elements to override higher overload currents resulting from re-energization.

Breaker Failure Protection

A simple “breaker has not opened” feature is standard. A complex breaker failure scheme can be easily implemented through a digital input and configurable output logic (logic gates and timers).

Breaker Health

The breaker health threshold is set by the user to achieve “just in time” maintenance. When the cumulative I^2 value exceeds the threshold, an alarm is issued.

Configurable Logic

Up to a maximum of 4 configurable logic schemes can be implemented into the MIF II by means of using a set of 4 pre-configured logic gates and timer cells. A graphical user interface is provided for configuration of MIF II logic. The inputs of the MIF II configurable logic can be assigned to contact outputs and/or LEDs.

Circuit Breaker Control

The MIF II permits operation of the circuit breaker. Breaker opening and closing operations can be carried out by programming specific outputs, and digital inputs can be used for verifying the success of the operation.

Autorecloser

The automatic recloser is intended for use in three-pole tripping schemes and single breaker applications. Up to four reclosing "shots" are possible prior to locking out. Each shot has an independently programmable dead time.

The autoreclosing scheme provides outputs that can be used to modify circuit protection settings between shots.

User Interfaces

Display

Measurement data (actual values), fault reports for the last five trips, and settings are shown on the 16x2 characters LCD display.

Status LEDs

The MIF II incorporates 6 LED indicators in the front plate. The first one is a green LED identified as "READY", used to indicate the status of the protection elements. When "ON" it means the relay is energized and ready to protect, and at least one protection element has been enabled.

The second one is a red LED used for TRIP indication. It will be "ON" when a fault occurs and the relay energizes the trip outputs. Once energized, it will remain latched until the ESC/RESET key is pressed for three seconds to RESET the relay.

Four additional LEDs are programmable in function and color. The factory default functions of the programmable LEDs are: Phase Trip, Ground Trip, 50 Trip, and Pickup, while the color is set to RED, and

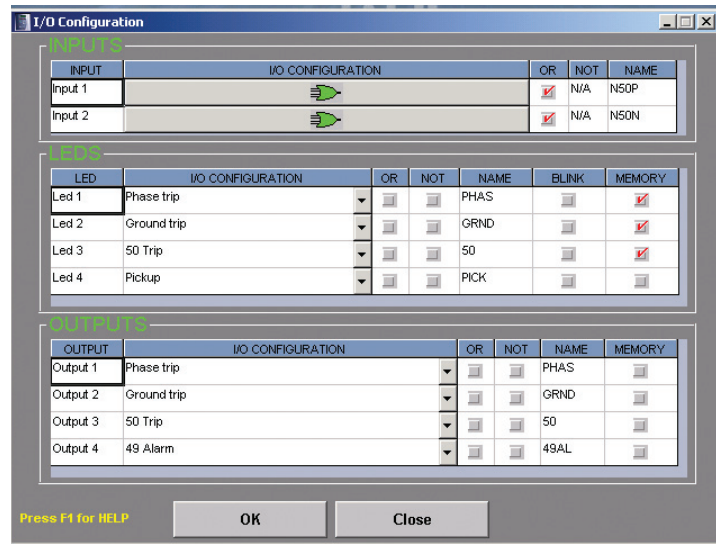

Inputs, outputs and LEDs can be easily configured using EnerVista™ MII setup program

the status memory as self-resetting. The user may change the function and status memory through the use of the EnerVista™ software.

The LED color can be modified using the relay keypad. The status memory may be programmed either self-resetting or latching. If programmed as self-resetting, when the associated function drops out the corresponding LEDs turn off. If programmed as latched, the LED will remain "ON" until the ESC/RESET key is pressed for three seconds to reset the relay.

In order to test LEDs, pressing the ESC/RESET key for three seconds will turn "ON" all LEDs. When the key is released, the LEDs will turn off (except if the function pickups

are still active). This allows easy testing of the equipment.

Keypad

A five-button keypad allows user access for easy relay interrogation and change of settings.

Access to events and oscillography records, and unit configuration is possible only through PC communication.

Self Test Diagnostics

Comprehensive self-test diagnostics occur at power up and continuously during relay operation. Any problem found by self-tests causes an alarm and an event is logged.



Communication Ports

A front mounted RS232 and a rear RS485 port allow easy user interface via a PC. ModBus® RTU protocol is used for all ports. The relay supports baud rates from 300 to 19,200 bps. Up to 32 Multilin devices can be addressed on a single communications channel. A unique address must be assigned to each relay via a setting when multiple relays are connected.

MultiNet™ compatible

MultiNet™ is a communications module that provides Multilin serial ModBus IEDs with ModBus TCP/IP communications over Ethernet, allowing connection to fiber optic LAN and WAN network systems.

MultiNet™ has the capability to connect up to 32 serial ModBus devices eliminating complex wiring and additional communications converters, and providing a streamlined and economical Ethernet hub. Unlike most communications converters that are designed for commercial use, MultiNet™ is environmentally hardened to withstand severe utility and industrial conditions.

- Converts Modbus RTU over RS485 into Modbus TCP/IP over Ethernet
- Supports both 10BaseT and 10BaseF fiber connections
- Connect up to 32 RS485 serial devices to an Ethernet network
- Modbus TCP/IP provides multiple SCADA masters allowing simultaneous communications to the same IED

- Flexible mounting options allow retro-fit to existing devices
- Industrially hardened for utility and industrial applications
- Simple “plug & play” device setup with EnerVista™ software

MultiNet™ gives you the ability to connect MII serial devices to new or existing Ethernet networks. It has a 10Base-F fiber optic interface that provides high EMI/RFI immunity and inherent electrical isolation over long cable runs. MultiNet™ setup is simple, with a Windows® based EnerVista™ software program for installing and configuring the communication drivers.

EnerVista™ Software

The EnerVista™ Suite is an industry-leading set of software programs that simplifies every aspect of using the relay. The EnerVista™ suite provides all the tools to monitor or the status of the protected asset, maintain the relay, and integrate information measured into DCS or SCADA monitoring systems. Convenient COMTRADE and Sequence of Events viewers are an integral part of the UR Setup software included with every UR relay, to carry out postmortem event analysis to ensure proper protection system operation.

EnerVista™ Launchpad

EnerVista™ Launchpad is a powerful software package that provides users with all of the setup and support tools needed for configuring and maintaining Multilin

products. The setup software within Launchpad allows configuring devices in real-time by communicating using serial, Ethernet, or modem connections, or offline by creating setting files to be sent to devices at a later time.

Included in Launchpad is a document archiving and management system that ensures critical documentation is up-to-date and available when needed. Documents made available include:

- Manuals
- Application Notes
- Guideform Specifications
- Brochures
- Wiring Diagrams
- FAQs
- Service Bulletins

Viewpoint Monitoring

Viewpoint Monitoring is a simple-to-use and full-featured monitoring and data recording software package for small systems. Viewpoint Monitoring provides a complete HMI package with the following functionality:

- Plug-&-Play Device Monitoring
- System Single-Line Monitoring & Control
- Annunciator Alarm Screens
- Trending Reports
- Automatic Event Retrieval
- Automatic Waveform Retrieval

Dimensions

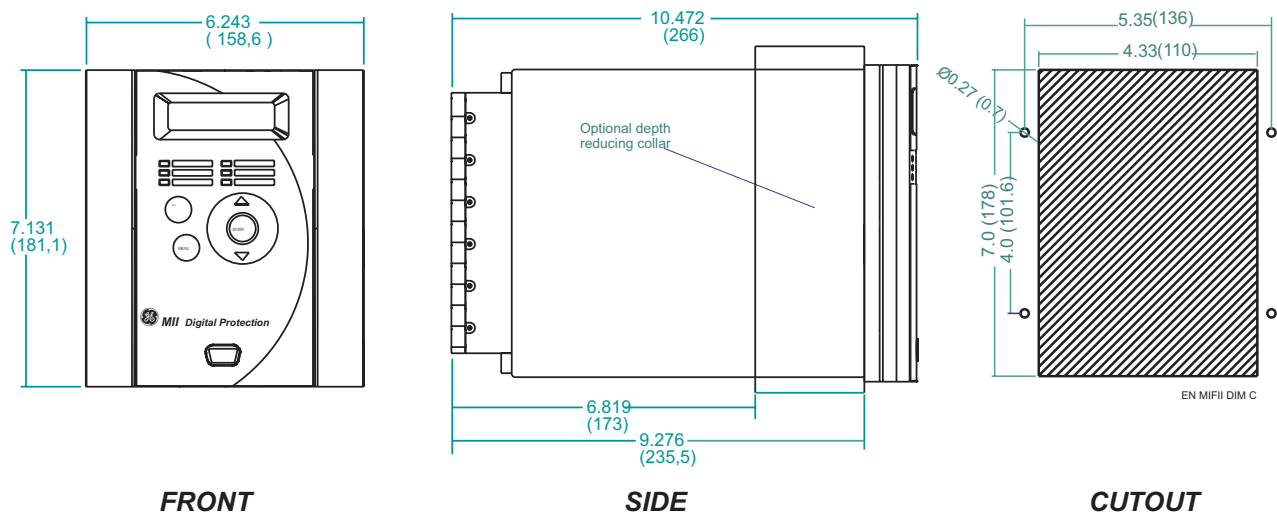

Typical Wiring

NOTES:
 SUITABLE DISCONNECT DEVICES RECOMMENDED
 LOCATED NEAR THE RELAY
 OVERVOLTAGE CATEGORY: II

20 A MAX CIRCUIT BREAKER
 LOCATED BEFORE
 POWER INPUT

ALTERNATIVE CT WIRING FOR
 RESIDUAL GROUND SENSING

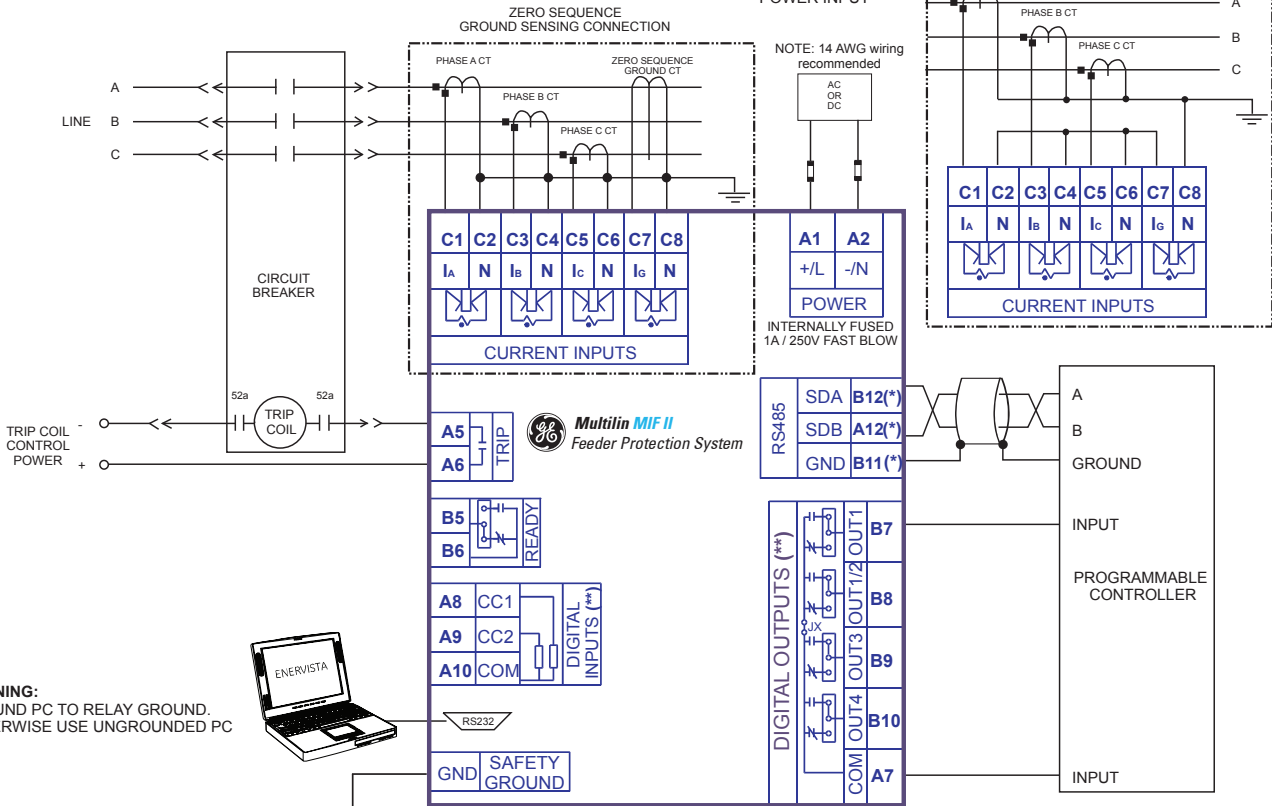

WARNING:
 GROUND PC TO RELAY GROUND.
 OTHERWISE USE UNGROUNDED PC

(*) Terminals B12, A12 and B11 must be connected to SELV (safety extra-low voltage) parts (on the PLC). They are not to be tested for hipot test under any circumstance

() In the basic model, inputs and outputs are configured as follows:**

INPUTS	OUTPUTS
CC1: Disable 50P Function	OUT1: Phase Trip
CC2: Disable 50G Function	OUT2: Ground Trip
	OUT3: 50 Trip
	OUT4: 49 Alarm

Technical Specifications

PROTECTION

PHASE / GROUND TIME OVERCURRENT

Current: Fundamental
Pickup Level: 0.1 – 2.4 times In (rated current) in steps of 0.01 x In (51P & 51G if 1/5 A ground models), 0.005-0.12 A (51G in sensitive ground model), 0.002-0.048 A (51G in very sensitive ground model)
Dropout Level: 97% (typical) of Pickup
Level Accuracy: ±1% of injected current at rated current ±3% in the complete range
Curve Shapes: IEC (B.S.) A/B/C
Level: ±1% at the rated current ANSI Inverse, Very Inverse or Extremely Inverse IAC Inverse, Very Inverse, Extremely Inverse, Inverse Short or Inverse Long
Time Dial: Time delayed (0.00 to 600.00 sec. in steps of 0.01 sec. 0.05 to 2 in steps of 0.01 for IEC curves 0.5 to 20 in steps of 0.1 for ANSI curves 0.5 to 10 in steps of 0.1 for IAC curves)
Reset Type: Instantaneous
Timing Accuracy: ± 5% + 50 ms of set time for 2 < I < 20 times the Actual Pickup Level for IEC/ANSI/definite time curves. ± 6% of set time for 2 < I < 20 times the Actual Pickup for IAC curves

Type/measure time: DFT of 1 cycle

PHASE / GROUND INSTANTANEOUS OVERCURRENT (50P1, 50P2, 50G1, 50G2)

Current: Fundamental
Pickup Level: 0.1 to 30.0 times In (rated current) in steps of 0.1 x In. (50P1/P2 & 50G1/G2 for 1/5 A ground models) 0.005 to 1.5 A (50G1/G2 for sensitive ground models) 0.002 to 0.6 A (50G1/G2 for very sensitive ground models)
Dropout Level: 97% (typical) of Pickup
Overreach: < 2%
Time Delay: 0.00 to 600.00 sec. in steps of 0.01 s
Reset Type: Instantaneous
Operate Time: Between 20 and 30 ms for I> 1.5 x Actual Pickup
Timing Accuracy: ± 3% of settled time for I > 1.5 times the Actual Pickup
Type/measure time: DFT of 1 cycle

METERING

FUNDAMENTAL CURRENT

Accuracy: ±1% at In ±3% in the complete range

MONITORING

OSCILLOGRAPHY

Records: 1 x 24 cycles
Sampling rate: 8 samples per power frequency cycle
Triggers: Any element pickup or operation Digital input configured as oscillography trigger Communications command
Information: AC input channels Digital input/output channels Self-test events

EVENT RECORDER

Capacity: 32 events
Time-tag: To 1 millisecond
Triggers: Any element pickup, operation or reset Digital input/output change of state Self-test events

COMMUNICATIONS

Local Communication: 2x16 LCD Display 5 button frontal keypad
Remote Communication (local or remote PC and communications net):
Mode: ModBus® RTU
Baud rate: 300 to 19200 bps
DB9 connector for RS232 ports on the front (1) and RS485 or IEC 60870-5-103 on the rear

INPUTS

AC CURRENT

Secondary Rated Current: 1 or 5 A depending on the selected model, or 50 mA for sensitive ground models
Frequency: 50 / 60 Hz ±3 Hz (The unit can be set to 50 or 60 Hz) < 0.2 VA @ In = 5A secondary < 0.08 VA @ In = 1A secondary < 0.08 VA @ In = 1A sensitive ground, secondary
Relay Burden:
Current Withstand: 4 x In continuously 100 x In for 1 sec.

DIGITAL INPUTS

Voltage Level: 300 Vdc maximum for HI power supply 75 Vdc maximum for LO power supply
Recognition Time: < 4 ms

POWER SUPPLY

LOW RANGE

Rated DC Voltage: 24 to 48 Vdc
Min./Max. DC Voltage: 19 / 58 Vdc

HIGH RANGE

Rated DC Voltage: 110 to 250 Vdc
Min./Max. DC Voltage: 88 / 300 Vdc
Rated AC Voltage: 110 to 230 Vac @ 50 – 60 Hz
Min./Max. AV Voltage: 88 / 264 Vac @ 50 – 60 Hz

Power Consumption: Max. = 10 W
Backup time: (date, time and log memory) without power supply voltage > 1 week

OUTPUTS

OUTPUT RELAYS

Configuration: 6 Electro-Mechanical Form C Silver alloy suited for inductive loads
Contact Material:

Maximum Operating Voltage: 400 Vac

Continuous Mode Current: 10 A at 250 Vac, general purpose ¾ HP, 124 Vac 1-1/2 HP, 250 Vac 10A, 250 Vac, 0.4 PF, B300 pilot duty 30 A
Make and Carry: 4000 VA
Breaking: 4000 VA

RELAY CONTACTS

Max rating for 10,000 operations

	Voltage	M/C	M/C (cont.)	Break 0.2 seg	Max Load
DC Resist	24 Vdc	10A	48A	10A	384W
	48 Vdc	10A	48A	2.6A	125W
	125 Vdc	10A	48A	0.6A	75W
AC Resist	250 Vdc	10A	48A	0.5A	125W
	120Vdc	10A	48A	10A	1920VA
	250 Vdc	10A	48A	10A	4000VA
Inductive (PF=0.4)	250 Vdc	10A	30A	10A	1000VA

MECHANICAL CHARACTERISTICS

- Metallic package in 1/4 19" rack and 4 units high
- Protection class IP52 (according to IEC 529)

ENVIRONMENTAL

Temperature:
Storage: -40°C to +80°C
Operation: -20°C to +60°C
Humidity: Up to 95% without condensing
Pollution Degree: 2

PACKAGING

Approximate Weight:
Net: 8.8 lbs (4 kgs)
Ship: 9.9 lbs (4.5 kgs)

TYPE TESTS

TEST	STANDARD	CLASS
Insulation Test Voltage:	IEC 60255-5	2kV, 50/60 Hz 1 min
Surge Test Voltage:	IEC 60255-5	5 kV, 0.5 J/3 positive pulses and 3 negative.)
1 MHz Interference:	IEC 60255-22-1	III
Electrostatic Discharge:	IEC 60255-22-2 EN 61000-4-2	IV 8 kV in contact, 15 kV through air
Radio interference:	IEC 60255-22-3: 40 MHz, 151 MHz, 450 MHz and cellular phone.	III
Radiated Electromagnetic fields with amplitude modulation:	ENV 50140	10 V/m
Radiated Electromagnetic fields with amplitude modulation. Common mode.	ENV 50141	10 V/m
Radiated Electromagnetic fields with frequency modulation.	ENV 50204	10 V/m
Fast Transients:	ANSI/IEEE C37.90.1 IEC 60255-22-4 BS EN 61000-4-4	IV IV
Magnetic fields at industrial frequency:	EN 61000-4-8	30 AV/m
Power Supply interruptions:	IEC 60255-11 IEC 57 (CO) 22	B
Temperature:	EN 50111	B
RF Emission:	EN 50111	B
Sinusoidal Vibration:	IEC 60255-21-1 IEC 60255-21-2	II I
Shock:	IEC 60255-21-1 IEC 60255-21-2	II I
Insulation Test:	IEC 255-5 (Tested on CTs, Power Supply terminals, Contact Inputs and Contact Outputs)	

APPROVALS

CE Conforms to 89/336/CEE and 73/23/CEE
CNL: C22.2 Certified
UL: UL508 Certified
ISO: Manufactured to an ISO9001 registered program

* Specifications subject to change without notice

User Interface

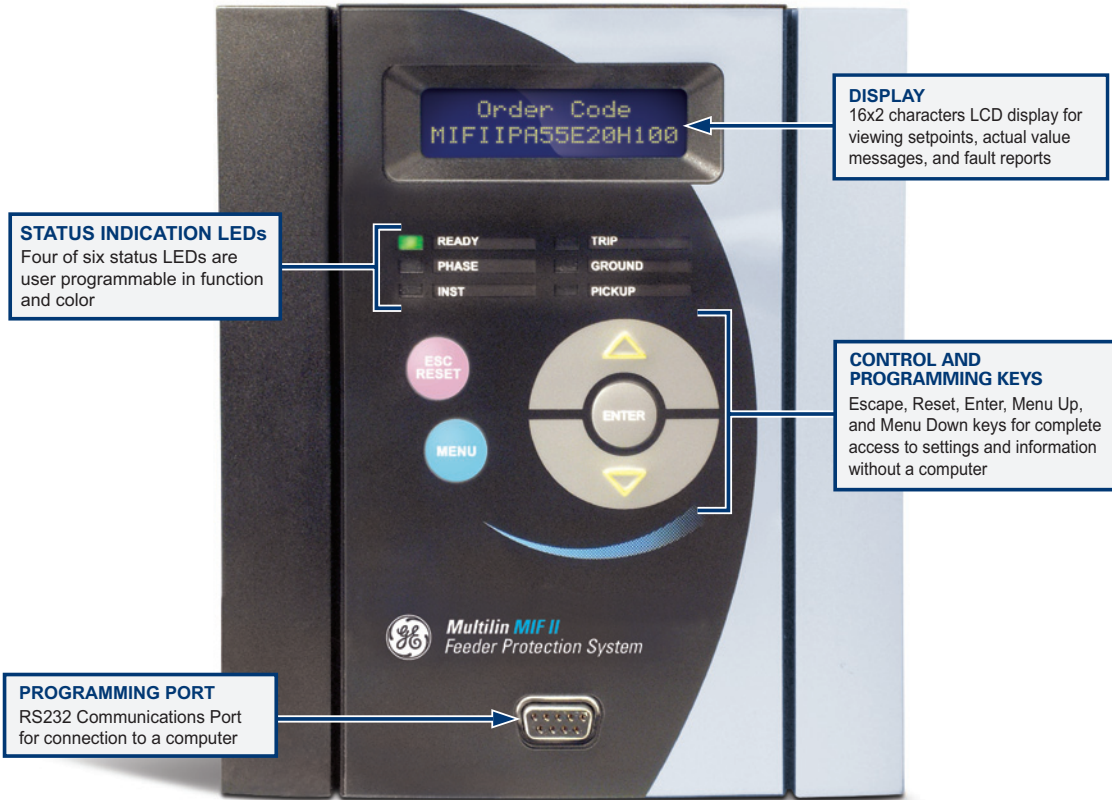

STATUS INDICATION LEDs
Four of six status LEDs are user programmable in function and color

DISPLAY
16x2 characters LCD display for viewing setpoints, actual value messages, and fault reports

CONTROL AND PROGRAMMING KEYS
Escape, Reset, Enter, Menu Up, and Menu Down keys for complete access to settings and information without a computer

PROGRAMMING PORT
RS232 Communications Port for connection to a computer

Ordering

	MIF	*	*	*	*	*	*	**	*	*	Description
Base Unit	MIF										Base Unit
Application		P									3 Phase + Ground relay
		N									Single Phase relay
Curves			A								ANSI Curves
			I								IEC Curves
			U								IAC Curves
			C								EPTAR-C curves (only for single phase models)
Phase Ranges				0							No CT (always for single phase models), Phase CT In = 1/5A (0.1-2.4 In) (three phase models)
				1							Phase CT In = 1 A (0.1-2.4 In)
				5							Phase CT In = 5 A (0.5-12 A)
Ground Range:					0						Ground CT = 1/5 A (0.1-2.4 In)
					1						Ground CT = 1 A (0.1-2.4 In)
					5						Ground CT = 5 A (0.5-12 In)
					N						Sensitive Ground In = 1 A (0.005-0.12 A)
					L						Very Sensitive Ground In = 1 A (0.002-0.048 A)
Language						E					English
						F					French
						T					Turkish
Options							0				Basic model (no options)
							1				Option 1 ¹
							2				Option 2 ²
Recloser Option								0			Without Recloser
								R			With Recloser (not available in basic model)
Power Supply									LO		24-48 Vdc (Range: 19-58 Vdc)
									HI		110-250 Vdc (Range: 88-300 Vdc)
											110-230 Vac (Range: 88-264 Vac)
Protocol										0	Standard Model (Modbus RTU)
										C	Protocol IEC 60870-5-103
Conformal Coating										0	Without Harsh Environment Conformal Coating
										H	With Harsh Environment Conformal Coating

¹ Configurable I/O/LEDs, event recording, oscillography
² Option 2 includes all Option 1 features, plus cold load pickup, breaker failure to open protection, breaker monitoring, breaker1ng maintenance and configurable logic