

Multilin Meter Enclosure

Enclosure Option for GE's EPM 2200/6000/6010/7000 Meters Pre-Wired, Configured and Economical Solution for Retrofit and Small Metering Systems

Expanding existing switchgear or installing new metering capability can be challenging due to space limitations, downtime and installation and equipment costs. GE's Multilin™ Meter Enclosure is a pre-wired configured, economical solution for both retrofit expansions and small scale meter installations that allows the expansion of existing switchgear capability without expensive and time-consuming design.

When ordered as a meter option the enclosure provides a factory pre-wired, installation-ready metering solution that further drives energy cost savings, by enabling the measurement of key energy usage information along multiple metering points for new or existing systems.

Ordering the enclosure is simple when selected as an option during meter configuration ensuring correct pre-wired meter-compatible delivery.

Key Benefits

- Easy, rapid installation for new or existing switchgear capability through a factory-wired, tested enclosure with installed meter, eliminating ordering, wiring and installation errors
- Extend metering capability with new systems and existing switchgear without system installation downtime
- Factory tested and installation ready with guaranteed compatibility with GE's EPM meter family
- Simplified ordering through an enclosure option ensures correct pre-wired meter-compatible delivery
- NEMA 1 tested and UL/CUL certified

Applications

GE's Multilin™ Meter Enclosure can be used for both new and retrofit meter installations where no metering compartment is available. Common example applications include expanding meter functionality for:



Industrial Tenant Monitoring: Increasing tenant or energy awareness by adding targeted metering to existing systems for industrial applications, such as commercial/residential buildings, data centers, manufacturing and educational campuses.



Advanced Metering: Adding advanced metering functionality to an existing switchgear installation to meet new requirements for energy management, power quality and metering data communications.



Easy and Rapid Installation

- Factory pre-wired, installation-ready, GE's metering solution eliminates wiring and associated errors for rapid installation
- Extend metering capability of new systems and existing switchgear without system installation downtime

Cost-Effective Retrofit Solution

- Save up to 200% versus the addition of a new switchgear cabinet
- Compact footprint makes effective use of existing allocated space
- Allows for new installations or the expansion of existing switchgear capability, without expensive, time-consuming design, eliminating system downtime

Reliable and Compatible

- Backed by a two-year warranty
- Simple meter option ordering ensures compatibility with GE's EPM meter family
- Comprehensive factory testing of both meter and enclosure together
- NEMA 1 tested and UL/CUL certified



Application Example

Challenge

Due to expansion in an existing manufacturing plant, a plant manager wants to gain more visibility of energy usage and state of power quality for specific areas of the plant to baseline measurements. However, the plant's low voltage switchgear panels are at capacity.

Solution

By connecting GE's EPM 7000 meter using GE's Multilin Meter Enclosure, the manufacturing client can reduce costs by over 200% compared with installing a required expansion switchgear section separately. Furthermore, there is a space savings advantage with the Multilin Meter Enclosure, as it has a smaller physical footprint, which allows for mounting in already designated spaces.



Existing Low Voltage Switchgear

Meter Enclosure Assembly

The installation of the GE's Multilin Meter Enclosure is simple, safe and eliminates downtime through simple mounting and wiring. The enclosure is UL/CUL certified and NEMA 1 rated, making it ideal for indoor environments. It is provided in two voltage configurations (120-240V and 277V) to ensure compatibility with customer installations. The standard equipment includes voltage fuses, a short block for current transformers, and a control power transformer for 277V power systems that are pre-wired and configured, to ensure quality and long-term reliability.

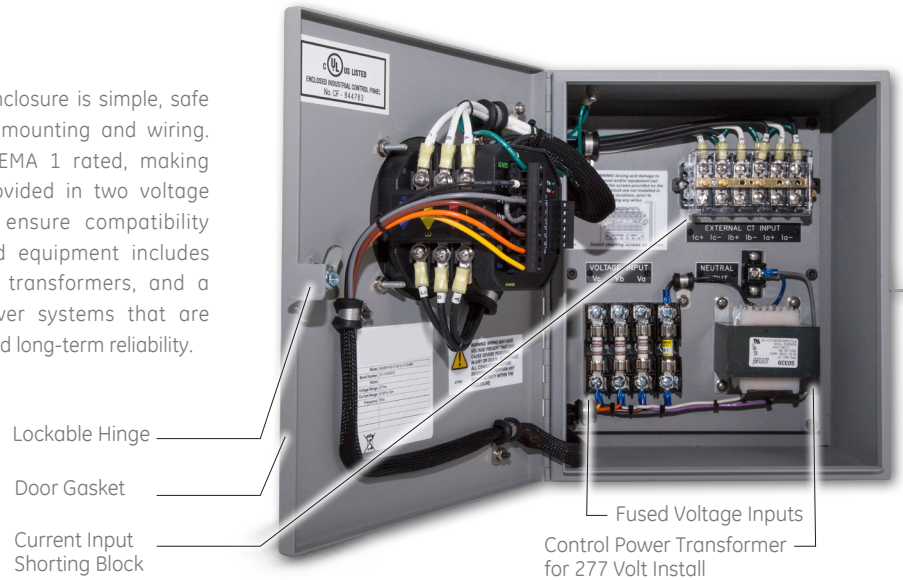

Wiring Diagrams

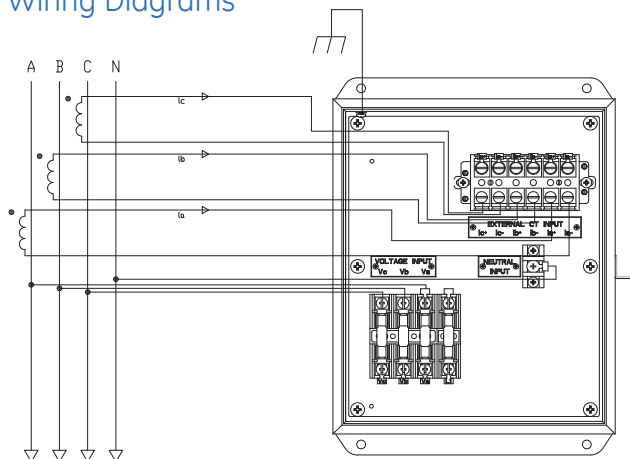

Wye Wiring for 120V Model

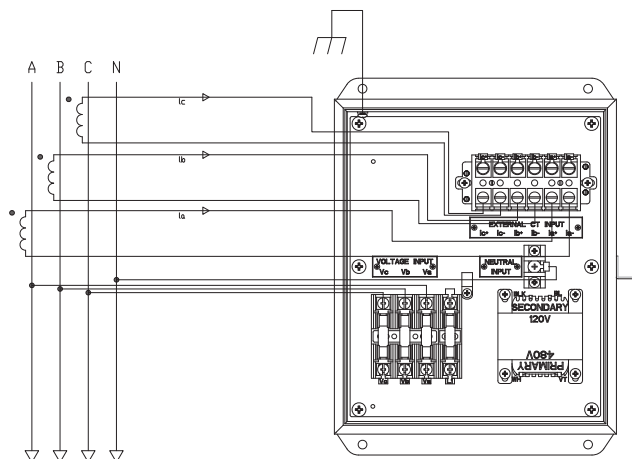

Wye Wiring for 277V Model

Dimensional Drawings

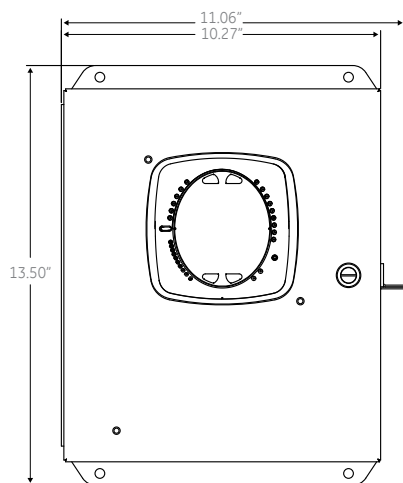

Enclosure Front Dimensions

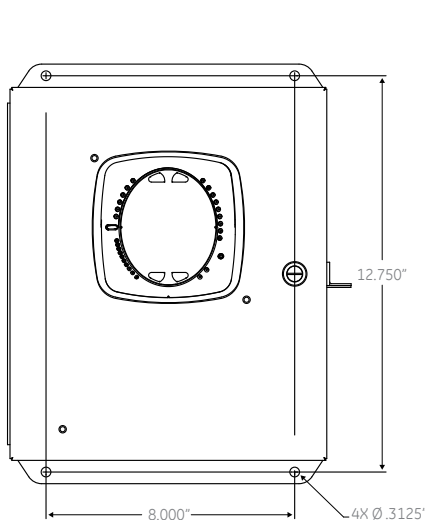

Mounting Hole Dimensions

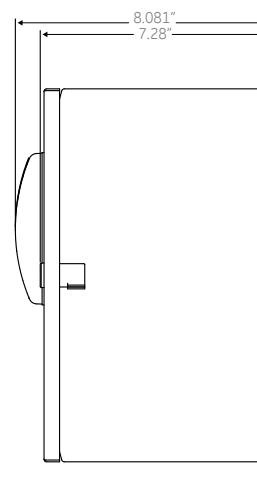

Enclosure Side Dimensions

Technical Specifications

COMPLIANCE

Type 1 Enclosure, UL/CUL Listed,
File Number: E358101

SPECIFICATIONS

ENVIRONMENTAL

Storage: -20°C to 70°C
 Operating: -10°C to 50°C
 Humidity: up to 95% RH, non-condensing
 Enclosure Rating: NEMA 1 - (indoor use)

MECHANICAL PARAMETERS

Dimensions: 8.08" x 11.06" x 13.50" (LxWxH)/
 205.23 mm x 280.92 mm x 342.9 mm (LxWxH)
 Weight: 25 lb/11.4 kg

Ordering Codes

EPM 2200 with Multilin Meter Enclosure

PL2200	*	*	*	Description
Enclosure	ENC120 ENC277			NEMA1 Rated - Indoor, Single Meter Enclosure, 120V NEMA1 Rated - Indoor, Single Meter Enclosure, 277V
Metering Options		A1 B1 C1 BN		Volts and Amps Meter Volts, Amps, Power and Frequency Volts, Amps, Power, Frequency and Energy Counters BACnet Volts, Amps, Power, Frequency and Energy Counters meter
Communications			X S B	None RS485 + Pulse BACnet MS/TP Serial and Modbus TCP/IP Ethernet

EPM 6000 with Multilin Meter Enclosure

PL6000	*	-	*	-	*	-	*	-	*	-	*	Description
Base type	PL6000											EPM 6000 with Multilin Meter Enclosure
Enclosure Option	ENC120 ENC277											NEMA1 Rated Indoor, Single Meter Enclosure, 120V NEMA1 Rated Indoor, Single Meter Enclosure, 277V
System Frequency			5 6									Frequency Option 50 Hz Frequency Option 60 Hz
Current Input					1A 5A							Current Input 1A Current Input 5A
THD							0 THD					No THD Option THD, Limits Alarms & One KYZ Pulse Output
Substitute LV Power Supply									LDC			No LDC Option Low Voltage DC Power Supply to substitute Standard AC/DC Power Supply
Ethernet Option											S E	Standard Serial Option Ethernet Option

Ordering Codes

EPM 6010 with Multilin Meter Enclosure

	PL6010	*	-	*	-	*	-	*	-	*	Description
Base Unit	PL6010										EPM 6010 with Multilin Meter Enclosure
Enclosure		ENC120									NEMA1 Rated Indoor, Single Meter Enclosure, 120V
Option		ENC277									NEMA1 Rated Indoor, Single Meter Enclosure, 277V
System				5							Frequency Option 50 Hz
Frequency				6							Frequency Option 60 Hz
Current Input						1A					Current Input 1A
						5A					Current Input 5A
Software (THD)								THD			THD, Limits Alarms and One KYZ Pulse Output
Power Supply									HI		HI Power Supply Option
									LDC		Low Voltage DC Power Supply (18-60) VDC

EPM 7000 with Multilin Meter Enclosure

	PL7000	*	-	*	-	*	-	*	-	*	-	*	Description
Base Unit	PL7000												EPM 7000 with Multilin Meter Enclosure
Enclosure		ENC120											NEMA1 Rated Indoor, Single Meter Enclosure, 120V
Option		ENC277											NEMA1 Rated Indoor, Single Meter Enclosure, 277V
System				5									Frequency Option 50 Hz
Frequency				6									Frequency Option 60 Hz
Current Input						1A							Current Input 1 A
						5A							Current Input 5 A
Software								A					Multimeter Function only
								B					Data Logging 2 MB Memory
								C					Power Quality Harmonics, 2 MB Memory
								D					Limits and Control, 2 MB
								E					64 Samples/cycle Waveform Recording, 3 MB Memory
								F					512 Samples/cycle Waveform Recording, 4 MB Memory
Power Supply										HI			HI Power Supply Option
I/O Slot 1											X		None
											C1		Four Channel Bi-directional 0-1 mA Outputs
											C20		Four Channel Bi-directional 4-20 mA Outputs
											E1		100 BaseT Ethernet
											E2		100BaseT Ethernet with IEC 61850 Protocol
											F1		Fiber Optic Serial Port-ST Terminated
											F2		Fiber Optic Serial Port-Versatile Link
											PS1		Four Pulse Outputs/Four Status Inputs
											RS1		Two Relay status Outputs/Two Status Inputs
I/O Slot 2											X		None
											C1		Four Channel Bi-directional 0-1 mA Outputs
											C20		Four Channel Bi-directional 4-20 mA Outputs
											E1		100 BaseT Ethernet
											E2		100BaseT Ethernet with IEC 61850 Protocol
											F1		Fiber Optic Serial Port-ST Terminated
											F2		Fiber Optic Serial Port-Versatile Link
											PS1		Four Pulse Outputs/Four Status Inputs
											RS1		Two Relay status Outputs/Two Status Inputs

GE
 650 Markland St.
 Markham, ON
 Canada L6C 0M1
 Toll Free (NA Only): 1-800-547-8629
 Tel: 905-927-7070
 Fax: 905-927-5098

GEGridSolutions.com

GE, the GE monogram, and Multilin are trademarks of the General Electric Company.
 GE reserves the right to make changes to specifications of products described at any time without notice and without obligation to notify any person of such changes.
 Copyright 2016, General Electric Company. All Rights Reserved.



imagination at work

GEA-12771C(E)
 English
 160315