



MBCI

Differential Feeder and Transformer Feeder Protection

Differential feeder protection requires a comparison of the currents entering and leaving the protected zone. Two MBCI relays are therefore required, one for each end of the feeder. A pair of pilot wires is used to transmit information between the two relays so that each can compare the current flowing at its respective end with the current at the other. The pilot wire carries analog circulating current - allowing correct operation even for low specification or ageing pilots.

When applying this protection to overhead lines, the limiting factor is generally the length of the pilot circuits: for cable feeders the limiting factors are more likely to be the level of line charging current and the method of system earthing.

Optional Extras

MRTP Supervision Relay

- Alarm and indication of pilot failure and supervision supply failure
- Suitable for pilot circuits insulated for 5 kV or 15 kV with pilot isolation transformers

MVTW Destabilising and Intertripping Relay

- Destabilises the feeder protection so that tripping occurs
- Intertripping: injects AC voltage into pilot circuit so that tripping occurs

MCRI Instantaneous Overcurrent and Start/Check Relay

- High speed operation
- Two phase and earth fault relay

MCTH Transformer Inrush Current Detector

- Allows MBCI to be applied to transformer feeders
- Blocks operation of the MBCI relay during transformer inrush conditions

Key Benefits

- High stability for through faults
- Fast operation for in zone faults
- Simultaneous tripping of relays at each line end
- Low current transformer requirements

Models Available

- MBCI 01 - Private pilots
- MBCI 02 - Telephone type



Features

Pilot supervision

Correct interchange of information over the pilot circuit is essential for the proper functioning of any differential feeder protection. The most common pilot failure is to the open circuit state, caused by the accidental excavation of buried pilots or storm damage to overhead pilots. With the pilots open circuited, the differential protection will be unstable and will trip the feeder if sufficient through current is flowing. For this reason, the circulating current system is often preferred, as such schemes will fail safe and trip so that attention is immediately drawn to the fault.

Destabilising/Intertripping

The remote unit of the differential feeder protection can be caused to operate provided sufficient line current is flowing, by open circuiting the pilots. If line current is not flowing, the remote unit can be operated (intertripped) by injecting a current into the pilots.

Overcurrent Check/Starting

Although the supervision scheme provides indication of pilot failure, it does not prevent the protection operating if primary current above setting is flowing. Where this hazard is unacceptable, it is necessary to add an overcurrent check feature to verify fault presence.

Emergency Use for Overcurrent Protection

In the event of a pilot failure which cannot quickly be rectified, the Translay S scheme may be adapted for use as a definite time overcurrent relay.

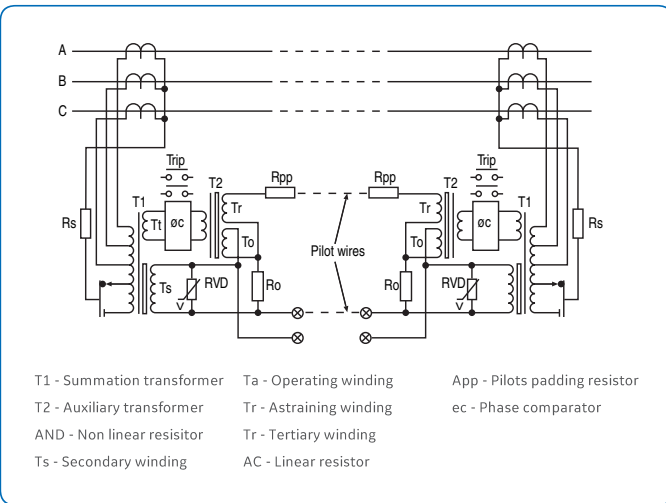

Figure 1 Basic circuit arrangement

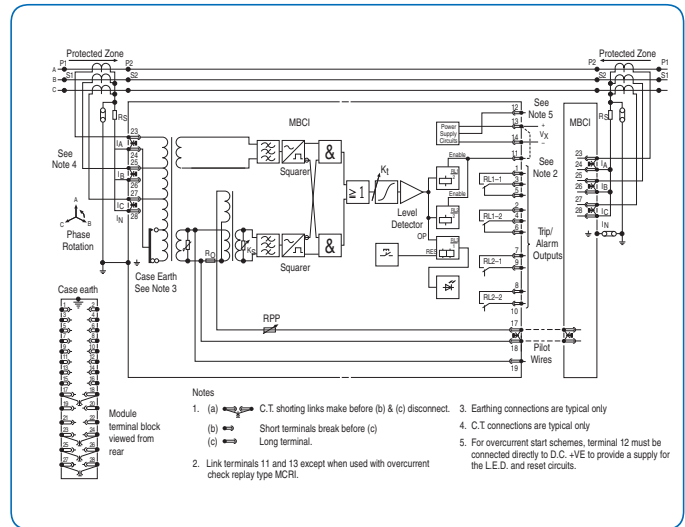

Figure 2 Application diagram: differential feeder protection relay type MBCI

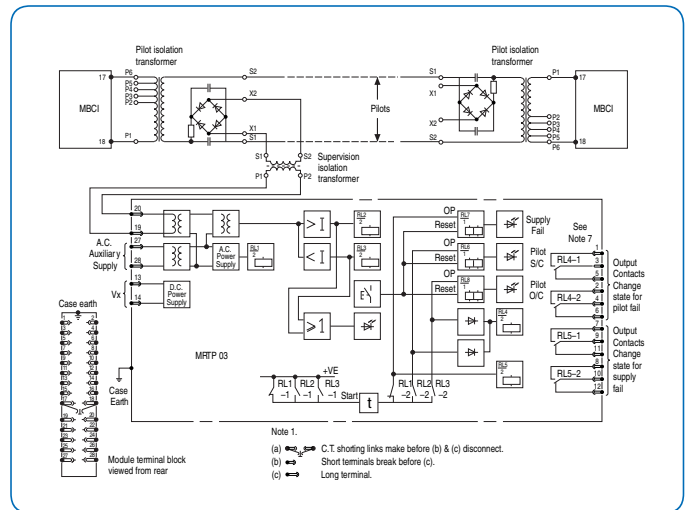

Figure 3 Application diagram: pilot supervision relay 15 kV isolation type MRTP 03

Transformer Feeders

(use of transformer inrush current detector)

The inclusion of a type MCTH relay, designed to provide a blocking signal in the presence of transformer inrush currents, enables a pilot wire differential protection scheme to be applied to a transformer feeder. Where line and therefore transformer energisation can occur at one end only of the transformer feeder, then an MCTH unit would be required on that side only.

Symbols:



15 kV isolating transformer



15 kV isolating transformer with injection filter

Scheme	Pilot Insulation Level (kV)	Supervision	O/C Start/Check	Arrangement of Equipment (Viewed from front)
A	5kV	—	—	1-----1
B	15kV	—	—	1-1-----1-1
C	5kV	•	—	2 1-----3 1
D	15kV	•	—	4 1-----1 1
E	5kV	—	•	1 5-----1 5
F	15kV	—	•	1 5-1-----1-1 5
G	5kV	•	•	2 1 5-----3 1 5
H	15kV	•	•	4 1 5-----1 1 5

Table 1. Typical scheme arrangements for plain feeders. See key below

Scheme	Pilot Insulation Level (kV)	Supervision	Transformer Arrangement	Arrangement of Equipment (Viewed from front)
I	5kV	—		1 8 9 7-----1 8 9 7 <small>Pilots</small>
J	15kV	—		1 8 9 7-----1 8 9 7
K	5kV	•		1 8 2 9 7-----1 8 9 7
L	15kV	•		1 8 4 9 7-----1 8 9 7
M	5kV	—		1 8-----1 8
N	15kV	—		1 8-----1 8
O	5kV	•		1 8 2-----1 8 9 7
P	15kV	•		1 8 4-----1 8 9 7

Table 2: Typical scheme arrangements for transformer feeders. See key below.

Nb.	Relay Type	
1	MBCI 01/02	Differential
2	M RTP 01	Pilot supervision and injection filter
3	M RTP 02	Injection filter
4	M RTP 03	Pilot supervision
5	M CAJ 01	Overcurrent start/check
6	M VTW 01	Destabilising
7	M VTW 03	Destabilising and intertripping Schemes A to D can be fitted with relay types 6 or 7 Schemes E to H can be fitted with type 6 which will provide destabilising if the overcurrent start/check relays MCAJ 01 have operated Schemes I to L must use type 7 or 8
8	M CTH 01	Transformer inrush current detector
9	M FAC 14	High impedance earth fault relay
10	M M LG	Test plug blockIt is advisable on all schemes to include the test unit to facilitate commissioning and routine testing. The unit will be situated on the right hand side of the scheme

Description

Differential Protection

The differential feeder protection circuit is derived from the well known Merz-Price circulating current system. Figure 1 shows the basic circuit arrangement. A summation current transformer T1 at each line end produces a single-phase current proportional to the summated 3-phase currents in the protected line. The neutral section of the summation winding is tapped to provide alternative sensitivities for earth faults.

In order to maintain the bias characteristic at the designed value it is necessary to pad the pilot loop resistance to 1 k. A padding resistor Rpp is provided in the relay for this purpose.

Pilot Isolation Transformers

When pilot isolation transformers are used, the pilot insulation level is raised to 15 kV.

Telephone Type Pilots (MBCI02)

When the pilots to be used are of the telephone type, the pilot differential voltage is limited by a metrosil (MBCI01). An alternative limiter based on a Zener diode is also available (MBCI02).

Destabilise and Intertrip facilities

MVTW01

Operation of the destabilising relay results in the summation current transformer in the differential relay being short circuited and the local relay prevented from tripping.

The remote relay then sees a single end feed condition and trips, provided the through current exceeds the no load fault setting of the protection.

MVTW03

The MVTW 03 incorporates a full bridge inverter, which receives signals from an oscillator circuit at a frequency of 80 Hz. This frequency was chosen because it lies sufficiently far from the pilot frequency of 50 or 60 Hz and cancellation of the intertripping signal cannot result.

To ensure intertripping occurs, the output relay injects a 20 mA intertrip current into the pilots and the remote MBCI sees the intertrip current as a differential current, which causes it to trip.

Transformer Inrush Current Detector Feature

A typical scheme for a delta-star power transformer is shown in figure 4. The line current transformers are connected in star on the delta side of the transformer. Appropriate choice of CT ratios ensures that for normal load and through fault conditions, equal currents flow into the differential tripping units (MBCI) at each end. A high impedance differential relay (type MFAC 14) is included in the neutral lead of the star connected line transformers to provide B-N protection on the delta side of the power transformer. The MFAC 14 high impedance differential relay may be used to initiate an intertrip unit (type MVTW 02).

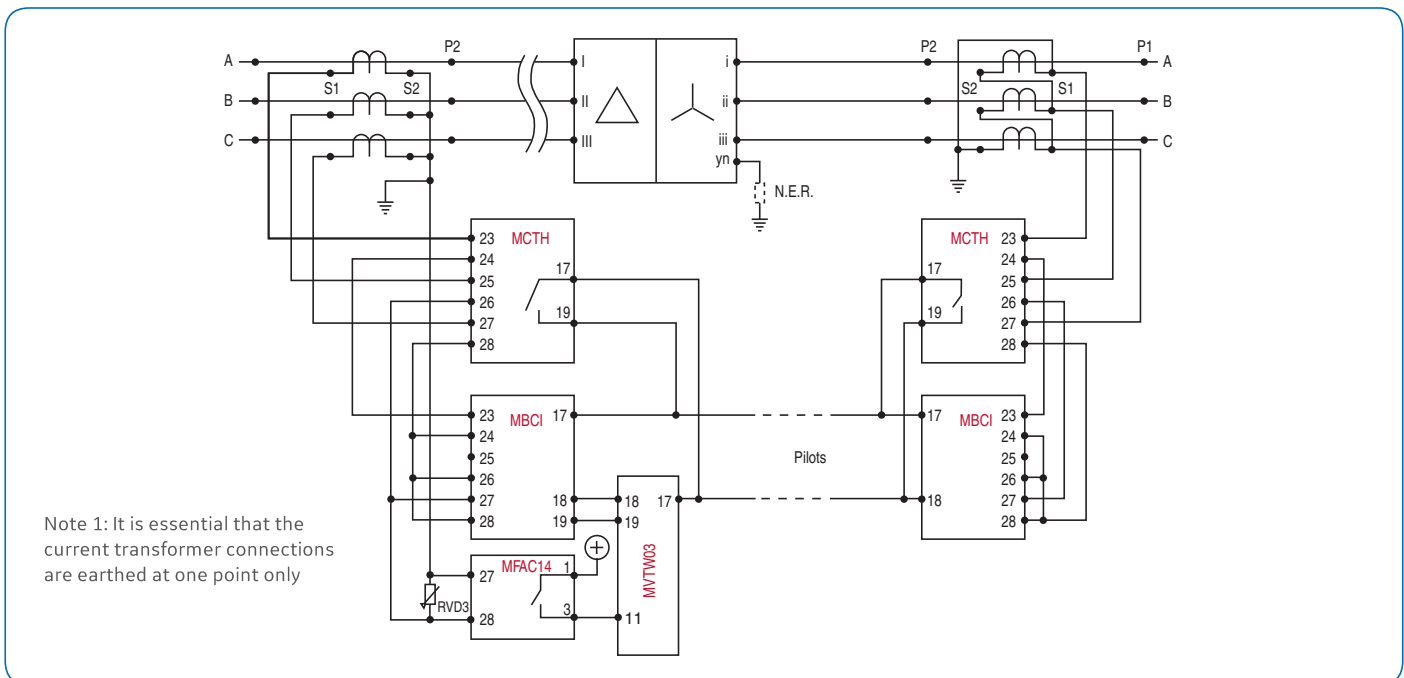

Figure 4 Typical application diagram: overall protection of transformer feeders

Technical Data (MBCI Relay)

Current rating (In)

1 A, 2 A or 5 A

Frequency rating

50 Hz or 60 Hz

Current Withstand Ratings

Duration (s)	Differential
continuous	2In
3	45In
2	55In
1	80In
0.5	100In

Current Circuit Burden

- Highest phase burden (with 3-phase rated current)
 - 6 VA N = 6
 - 3.5 VA N = 3
- At setting current 0.5 VA

Auxiliary supply

Rated voltage (Vx)	Operative range (V)	Current quiescent	Drain (mA) operated
24/27	19.2-32.4	30	17.5
30/34	24-37.5	15	175
48/54	37.6-72	15	175
110/125	87.5-150	15	90

Contacts

Contact arrangements: 2 make and 2 change-over

Contact ratings

- Make and carry for 0.2 s 7500 VA subject to maxima of 30 A and 300 V ac or dc
- Carry continuously: 5 A ac or dc
- Break ac.....1250 VA
 - dc.....50 W resistive
 -25 W inductive
 -L/R = 0.045 s
- Subject to maxima of 5 A and 300 V

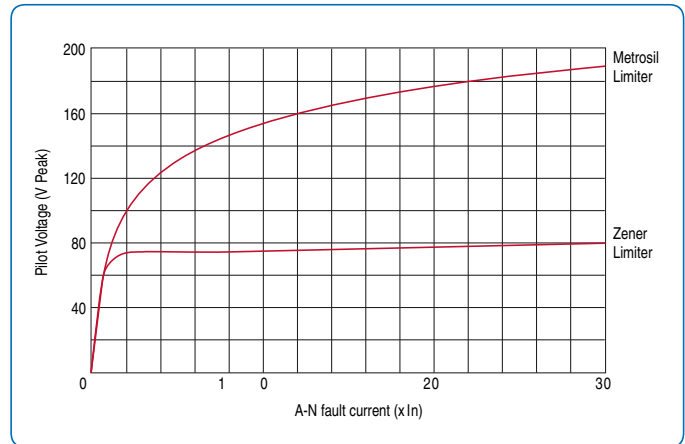

Figure 5 Pilot voltage characteristics

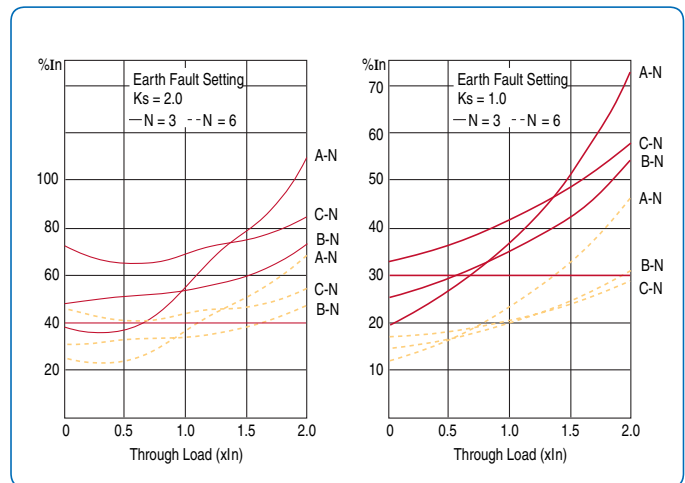

Figure 6 Minimum earth fault current for operation with through load

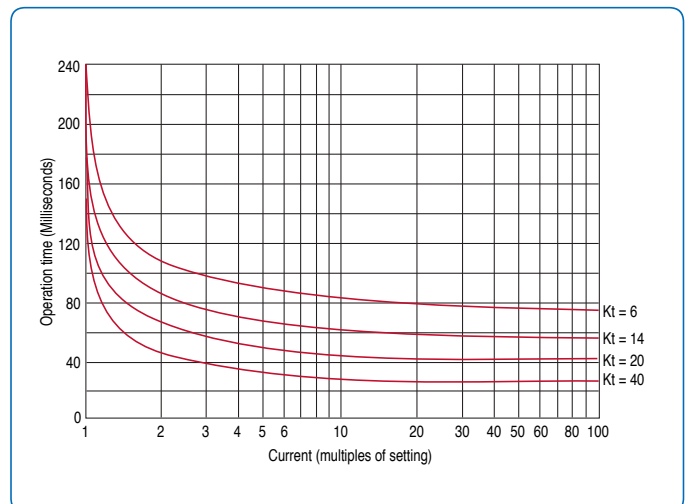

Figure 7 Time characteristics for internal faults

Pilots

Pilot Isolation

Pilot isolation transformers are required when any longitudinally induced voltage in the pilot circuit is likely to exceed 5 kV: in effect this means when protecting feeders operating at voltages in excess of 33 kV, unless these are short in length.

Pilot Current

The pilot current is typically 30 mA for normal through load conditions and rises to a maximum of 300 mA under through fault conditions.

Fault Settings for Plain Feeders

The input transformer has a summation ratio of 1.25:1:N where N = 3 for normal use. N = 6 is used where low earth fault settings are needed. The minimum operating current will therefore be dependent on the phase or phases involved in the fault. The minimum earth fault current (If) should be greater than twice the least sensitive earth fault setting to ensure rapid fault clearance.

The range of fault settings is shown in table 3.

Summation ratio = 1.25/1/N)	Fault	Settings	
		N = 3	N = 6
Ks is a setting multiplier and may be varied from 0.5-2.0	A - N	0.19 Ks.In	0.12 Ks.In
	B - N	0.25 Ks.In	0.14 Ks.In
	C - N	0.33 Ks.In	In 0.17 Ks.In
In is the rated relay current	A - B	0.8 Ks.In	
	B - C	1.0 Ks.In	
	C - A	0.44 Ks.In	
	A - B - C	0.5 Ks.In	

Table 3

Note: A stabilising resistor is required for single phase protection or when MBCI is fed from delta connected current transformers

Reduction of Induced Pilot Loop Voltage

Ideally, the pilot cores should be wormed (twisted together) so that the induced loop voltage is kept to a minimum.

Unit Protection of Transformer Feeders

Fault Setting

The relay internal summation is identical to that used for plain feeders but the turns ratio used is 2.25:6. This will result in secondary settings as given in the table below:

Relay setting in amps = $K_s \times I_n$ times the Constant in the table.

A to N	0.44
B to N	
new	0.17
A to B	0.44
B to C	0.17
C to A	0.12
3-phase	0.14

Where

K_s = setting multiplier which may be adjusted between 0.5 and 2.0

I_n = relay rated current

NB: The figures quoted in this table are those to be expected under conditions of secondary injection testing.

Note 1: There is a restricted earth fault relay in the neutral of the star connected CTs on the delta side of the power transformer. This provides protection against earth faults on the delta side of the power transformer when the infeed is into the delta. It will provide settings lower than any of the phase to neutral settings given above.

Note 2: The MBCI relay, when used in the transformer feed application, does not require a stabilising resistor.

Cases

Relay type MBCI is provided in case 6 as shown in Figure 8 on the next page.

Trusted by utilities, industry
and railways... worldwide

Information Required with your Order

Basic scheme reference (refer to table 1)

- Types of relay
- Pilot loop resistance and intercore capacitance values (this information is required to determine whether pilot isolating transformers are required for matching purposes)
- Pilot insulation level (5 kV or 15 kV)
- Is pilot supervision equipment required? / Is the overcurrent relay required? / Is the destabilising facility or destabilising /intertrip facility required?
- Pilot voltage: Metrosil (MBCI 01) or Zener limiting (MBCI • 02)
- Current rating
- Frequency rating
- Auxiliary DC supply rating
- Auxiliary AC supervision supply rating
- AC intertrip supply rating

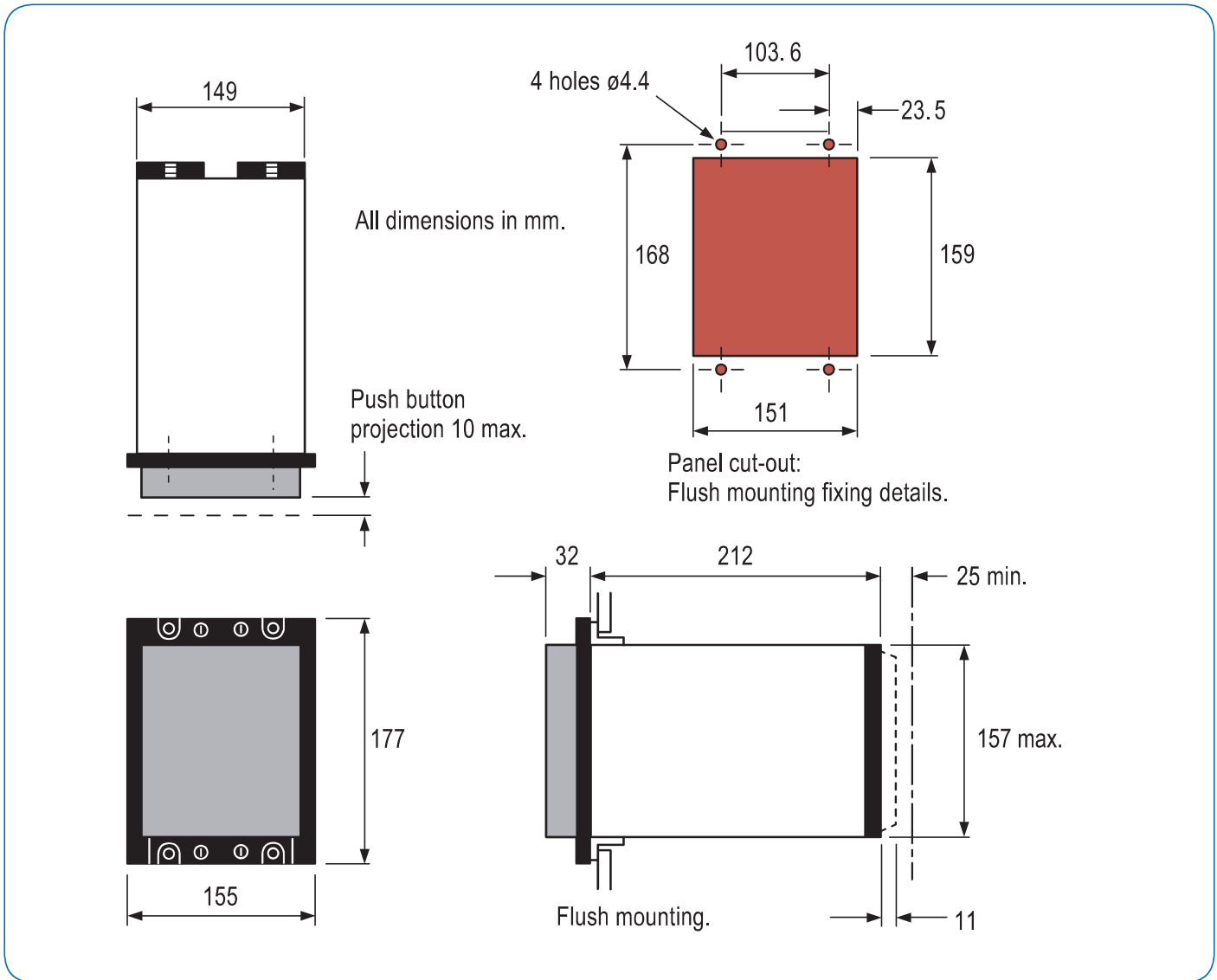

Figure 8 Case outline size 6

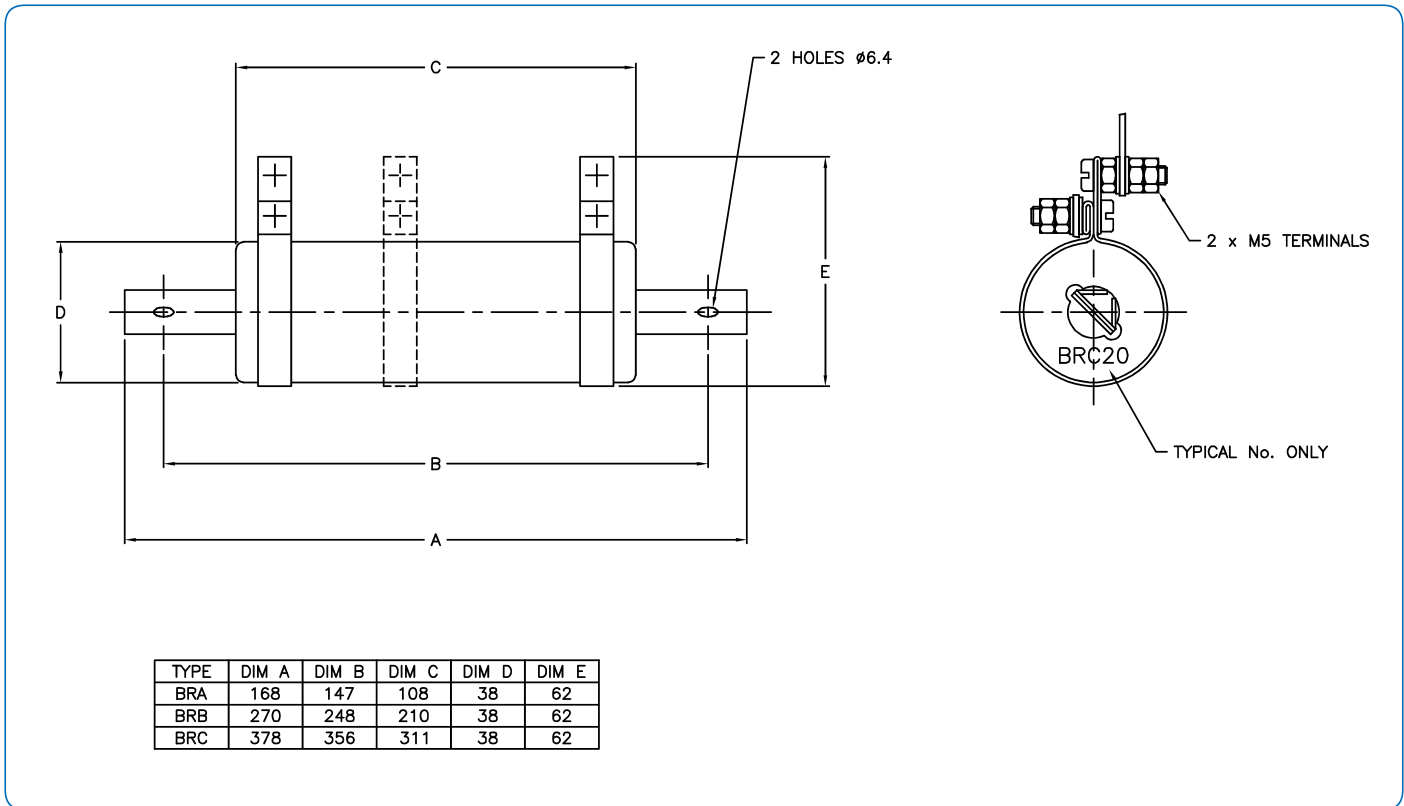

Figure 9 Stabilising resistor (BRC)

Device Track Record - Translay - S Schemes

MBCI is the second generation Translay - S product.

MBCI launched in 1983, with over 13 500 in service worldwide.

Sister product MHOR analog differential protection and MiCOM P541 numerical unit protection.

For more information please contact
GE
Grid Solutions

Worldwide Contact Center

Web: www.GEGridSolutions.com/contact
Phone: +44 (0) 1785 250 070

GEGridSolutions.com

IEC is a registered trademark of Commission Electrotechnique Internationale. IEEE is a registered trademark of the Institute of Electrical Electronics Engineers, Inc. Modbus is a registered trademark of Schneider Automation.

GE and the GE monogram are trademarks of General Electric Company.

GE reserves the right to make changes to specifications of products described at any time without notice and without obligation to notify any person of such changes.

MBCI-Brochure-EN-2020-10-Grid-GA-0668. © Copyright 2020, General Electric Company. All rights reserved.



Imagination at work