

iSTAT M365

Power Quality Metering with Extensive Logging and Communications

The iSTAT M365 comprehensive power quality metering and communication features are ideal for utility, industrial and commercial power quality applications. The iSTAT M365 is an enhancement to the previous iSTAT M355 offering with extensive power quality perspective with the latest IEC 61000-4-30 Class A Edition 3 certification as well as supporting EN50160 reporting.

With 625 samples/cycle sampling frequency and 8GB of logging memory to capture waveform, disturbance events and measured values, users are empowered to assess and make power related decisions quickly and effectively as well as record data for reconciliation and service level evidence. The iSTAT M365 support of Modbus, DNP3, FTP and IEC 61850 Edition 2 along with GPS, IRIG-B and NTP time sync make it easy to integrate into new or existing systems.

Key Benefits

- IEC 61000-4-30 Class A Edition 3 certification supporting the latest power quality reporting standards
- Ideal for energy and power quality monitoring in applications such as utility substations, renewables, advanced industrial manufacturing, datacenters and hospitals with high resolution waveform recording requirements (up to 625 samples/cycle) and Class 0.2S Active energy metering accuracy with demand recording
- Standard 8GB logging memory with PQDIF and COMTRADE file storage
- Easy integration with RS232/485 Serial to support either GPS time sync or protocol communications as well as Ethernet and USB communications with protocol support for Modbus, DNP3, FTP and IEC 61850 Edition 2.
- Four available I/O module slots with up to 20 I/O to support multiple customizable I/O applications

Applications

- Power quality alarming/event capture for utility or industrial event investigation/reconciliation, ensuring uptime and predictive maintenance for critical power quality sensitive assets (utility substation, data centers, manufacturing, hospitals)
- Accurate Class 0.2S energy measurement (demand, time of use) and for utility or industrial applications
- High sampling data capture and control in applications such as utility generation or renewables
- Specialized utility/industrial power quality reporting for standards such as Class A IEC 61000-4-30 Ed. 3, IEC 61000-4-15 flicker, IEC 61000-4-7 harmonics and EN50160



Advanced Monitoring and Metering

- Class 0.2S active energy accuracy (IEC 62053-22)
- Harmonics to the 63rd order (Voltage, Current)
- Up to 625 samples/cycle waveform/transient recording
- 8 GB of memory for waveform and disturbance recording
- Class A IEC 61000-4-30 updated Edition 3 Power quality measurement and EN50160 reporting support

Advanced Communications and Control

- Standard communications Ethernet (RJ45), USB 2.0 and Serial (RS232, RS485 for either time sync or protocol communications)
- Supports Modbus, DNP 3.0, FTP and optionally IEC 61850 Ed. 2 Protocols
- Easy system integration with four available I/O modules with up to 20 I/O.

User Friendly with Low Commissioning Effort

- Available 5.7" color TFT display or 128x64 pixel display
- Universal power supply
- Easy to install 144mm square panel mounting
- Web page for easy monitoring of measurements and settings



Ensure asset uptime, monitor energy usage and power quality for Utility or Industrial Applications

The GE iSTAT M365 provides high performance power quality analysis functions collecting data to support the reporting of the latest IEC 61000-4-30 Class A Edition 3 and EN50160 international standards as well as evidence that can lead to the determination of the sources of faults, sags and swells and harmonics for corrective actions as well as monitoring energy usage and power quality.

Power quality data and events are captured, stored and time synced with the 8GB of logging memory allowing for reconciliation between providers and consumers as well as complete post-fault analysis of events or periodic standards reporting.

Energy Management Controller

Monitor branch circuits with revenue grade multifunction power meters

Continuous monitoring of power quality events & automatic waveform capture

High performance power quality monitoring & revenue class metering

GE iSTAT M365 Data Center Application

iSTAT M365

User Friendly Software Setup and Visualization

The iSTAT M365 utilizes QDSP setup software to allow for easy initial meter setup, configuration and data visualization.

Easy setup and data visualization using QDSP Software

Advanced Time Synchronization

The iSTAT M365 support multiple types of time Synchronization to ensure accuracy and Synchronization of various measurements and events to meet standards.

GE Reason RT43x GNSS clocks are recommended to provide accurate time Synchronization.

GPS Time Synchronization (PPS and NMEA)

- 1pps and serial RS232 communication with NMEA 0183 sentence support
- The interface is designed as 5 pole pluggable terminal (+5V for receiver supply, 1pps input and standard RS232 communication interface).

IRIG time code B (IRIG-B)

- Unmodulated (DC 5V level shift) and modulated (1 kHz) serial coded format with support for 1pps, day of year, current year and straight seconds of day as described in standard IRIG-200-04.
- Supported serial time code formats are IRIG-B007 and IRIG-B127 Interface for modulated IRIG-B is designed as BNC-F terminal with 600 Ohm input impedance.
- Interface for unmodulated IRIG-B is designed as pluggable terminal.

Network time protocol (NTP)

- Synchronization via Ethernet requires access to a NTP server.
- Note: NTP can usually maintain time to within tens of milliseconds over the public Internet, but the accuracy depends on infrastructure properties - asymmetry in outgoing and incoming communication delay affects systematic bias. It is recommended that dedicated network rather than public network is used for Synchronization purposes.



GE Reason RT43x GNSS clocks recommended for time synchronization

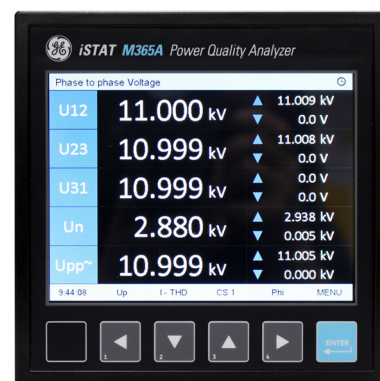

M365A available with 5.7" TFT display

Easy to Integrate Communications

The iSTAT M365 supports various communications connections and protocols for easy integration. It is equipped with standard communication port COM1 (Ethernet & USB) and an auxiliary communication port COM2 (RS232/RS485).

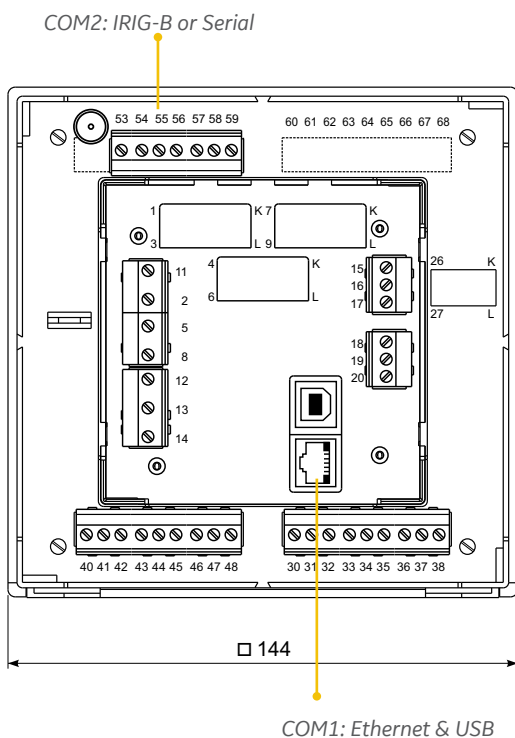

Port	Type	Communications Supported
COM1	Ethernet	Modbus, DNP3, IEC 61850 (optional)
	USB 2.0	Modbus
COM2	RS232/ RS485	Modbus, DNP3 RS232/RS485 communication and GPS time synchronization cannot be used at the same time. When GPS time synchronization is used, RS232/RS485 communication on COM2 is not available.

Versatile Display Options

The iSTAT M365 is available with 2 display options to best suit end user installations and data presentation requirements.

M365A - 5.7" TFT display

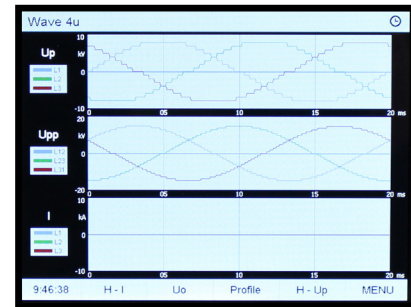
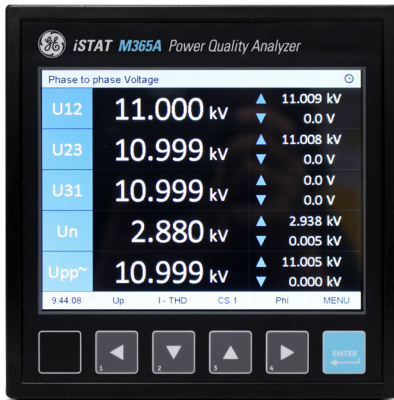

M365B - 128x64 pixel graphic LED display

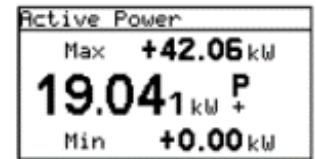
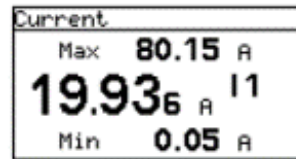
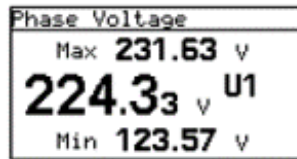

Web Server Data Visualization

The iSTAT M365 has a built-in web server to visualize device settings as well as measurements. Using a standard web browser users can access data without the need for additional software.

Power Quality Analyser - Class A
Model Type : M365A Waveform

Phase measurements	L1	L2	L3	Total	Others
Voltage	63.49 V	63.50 V	63.49 V		63.49 V
Current	1.0002 A	1.0002 A	1.0002 A	3.0006 A	1.0002 A
Real Power	63.26 W	63.27 W	63.26 W	189.79 W	
Reactive Power	5.50 var	5.51 var	5.50 var	16.51 var	
Apparent Power	63.50 VA	63.51 VA	63.50 VA	190.51 VA	
Power Factor	0.9962 Ind	0.9962 Ind	0.9962 Ind	0.9962 Ind	
Power Angle	4.97°	4.96°	4.96°	4.96°	
Displacement Power Factor	0.9962 Ind	0.9963 Ind	0.9963 Ind	0.9963 Ind	
THD-Up	0.01%	0.01%	0.01%		
THD-I	0.07%	0.08%	0.07%		
TDD-I	0.01 %	0.01 %	0.01 %		
Deformed Power D	0.00 var	0.00 var	0.00 var	0.00 var	
K-factor	1.00	1.00	1.00		
Current Crest factor	141.3 %	141.3 %	141.3 %		
DC Voltage	-0.01 V	-0.01 V	-0.02 V		
Phase to phase measurements	L1 - L2	L2 - L3	L3 - L1	Total	Others
Phase to phase voltage	109.97 V	109.97 V	109.96 V		109.97 V

Access Measurements data using a standardized web browser

Dimensional Drawing – iSTAT M365

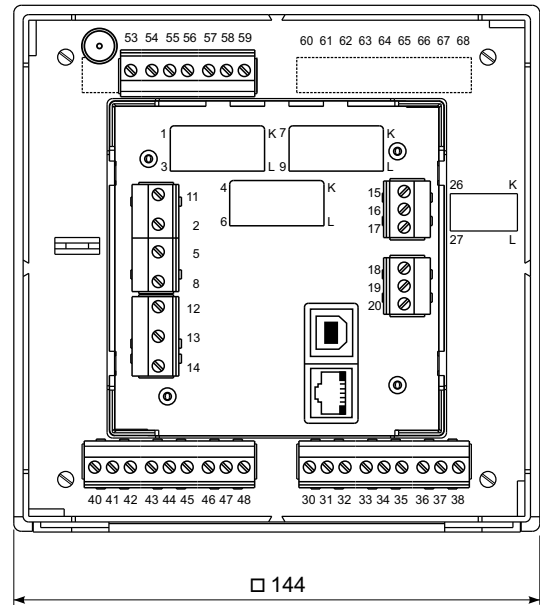
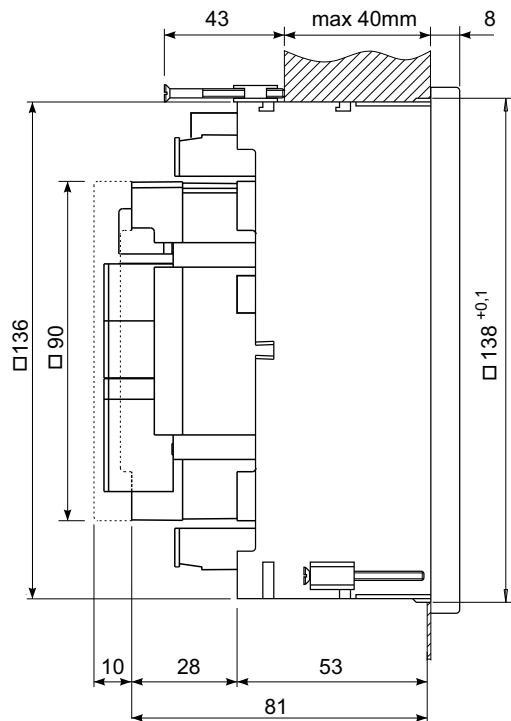

Measurements are provided in millimeters (mm)
 Recommended panel cut out is: 138 x 138 mm + 0.8mm
 Additional details are provided in the instruction manual

Wiring Diagrams

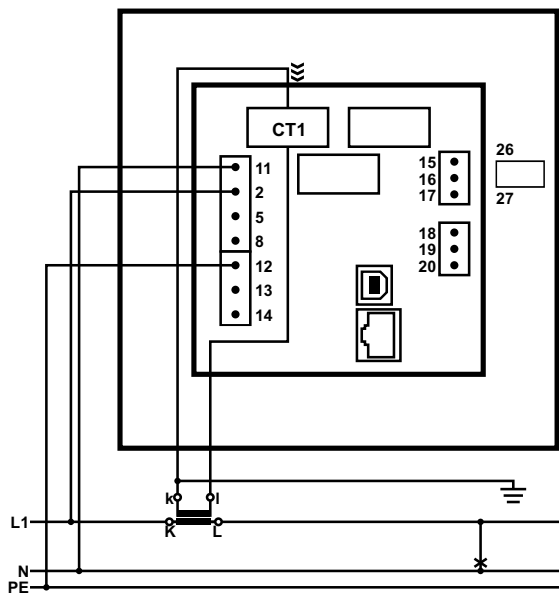

Connection 1b (1W)
 Single phase connection

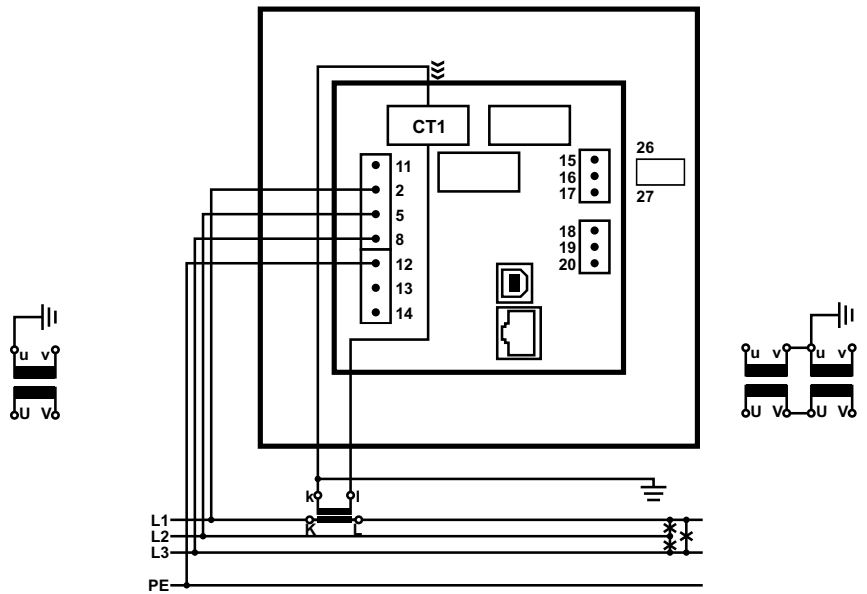

Connection 3b (1W3b)
 Three phase, three wire connection with balanced load

Wiring Diagrams (Cont'd)

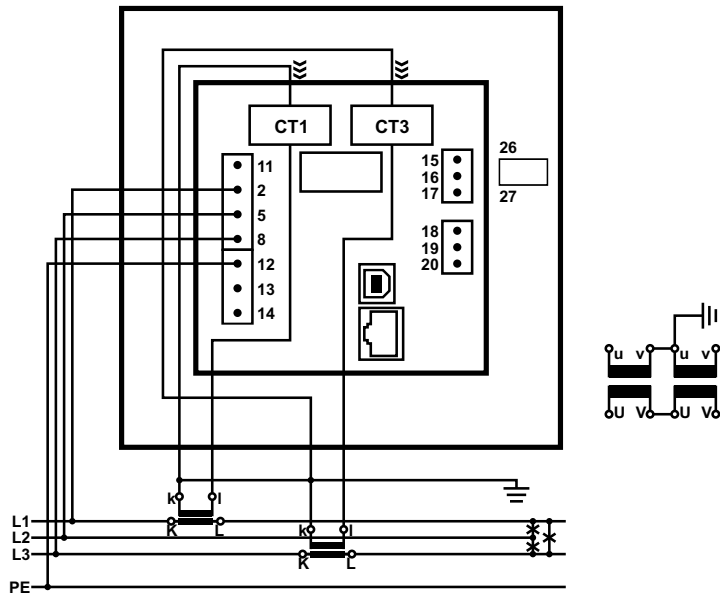

Connection 3u (2W3u)

Three phase, three wire connection with unbalanced load

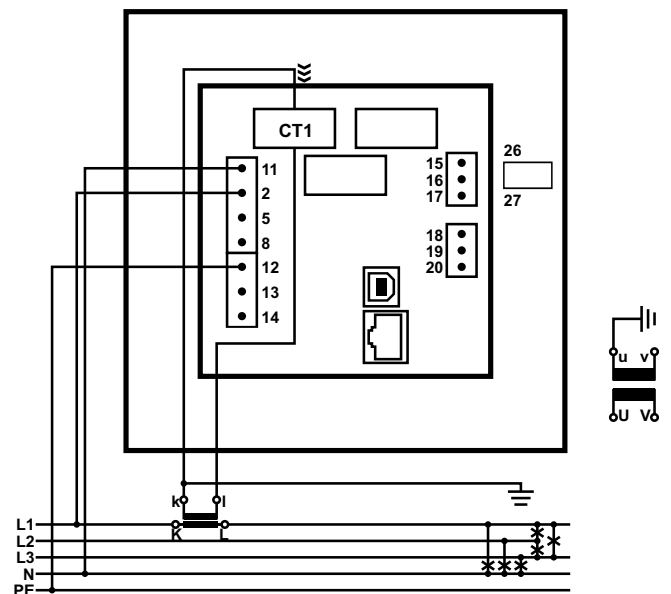

Connection 4b (1W4b)

Three phase, four wire connection with balanced load

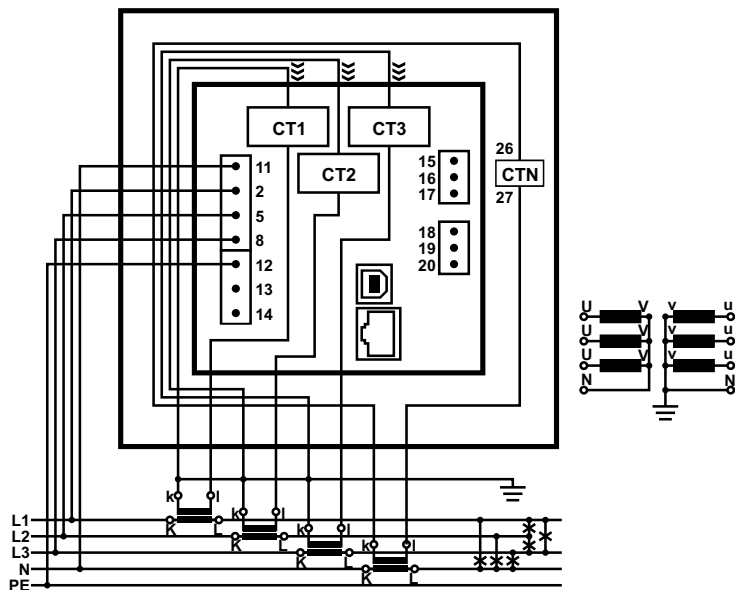

Connection 4u (3W4u)

Three phase, four wire connection with unbalanced load

Protective earth terminal 12 (PE) must ALWAYS be connected in all schemes. Fourth voltage channel is dedicated for measuring voltage between EARTH (PE, terminal 12) and NEUTRAL (N, terminal 11).

Technical Specifications

VOLTAGE MEASUREMENTS

- Number of channels: 4⁽¹⁾
 - Min. voltage for sync.: From starting voltage for SYNC (min value: 1 Vrms)
 - Nominal value (UN): 230 V_{LN}, 415 V_{LL}
 - Min. measured value: From starting voltage for all powers
 - Max. measured value (cont.): 600 V_{LN}; 1000 V_{LL}
 - Max. allowed value: 1.2 × U_N permanently
 - 2 × U_N: 10 s
 - Consumption: < U² / 4.2 MΩ per phase
 - Input impedance: 4.2 MΩ per phase
- ⁽¹⁾ 4th channel is used for measuring U_{EARTH-NEUTRAL}

CURRENT MEASUREMENTS

- Number of channels: 4
- Nominal value (I_{NON}): 1 A, 5 A
- Min. measured value: From starting current for all powers
- Max. measured value: 12.5 A sin. (I1-I3 only)
- Max. allowed value (thermal): 15 A cont. ≤ 300 A; 1s
- Consumption: < I² × 0.01 Ω per phase

FREQUENCY MEASUREMENTS

- Nominal frequency range: 50, 60 Hz
- Measuring frequency range: 16 – 400 Hz

MEASUREMENT METHOD

- Waveform sampling: 32 μs (625 Samples per Cycle)
- ADC resolution: 24 bit 8-ch simultaneous inputs
- Reading refresh rate: 100 ms – 5 s (User defined)
- Timestamp resolution: 1 ms

ACCURACY RATINGS

- Full accuracy specifications available in user manual
- Voltage L-N, L-L: ± 0.1 % acc. to EN 61557-12
- Current: ± 0.1 % acc. to EN 61557-12
- Active power (I_N = 5A): ± 0.2 % acc. to EN 61557-12
- Active power (I_N = 1A): ± 0.5 % acc. to EN 61557-12
- Active energy: Cl. 0.2S acc. to EN 62053-22
- Reactive energy: Cl. 0.5S acc. to EN 62053-24
- Frequency (f): ± 0.01 Hz acc. to EN 61557-12
- Power factor (PF): ± 0.5 % acc. to EN 61557-12
- THD (U): ± 0.3 % acc. to EN 61557-12
- THD (I): ± 0.3 % acc. to EN 61557-12
- Real time clock (RTC): < ± 1 s / day acc. to IEC61000-4-30

UNIVERSAL POWER SUPPLY

- Standard (high): CAT III 300 V
- Nominal voltage AC: 80 ... 276 V
- Nominal frequency: 40 ... 65 Hz
- Nominal voltage DC: 80 ... 300 V
- Consumption: < 8 VA typical
< 12 VA max. loaded I/O options
- Power-on transient current: < 20 A ; 1 ms

TIME SYNCHRONIZATION INPUT

- Digital input: GPS or IRIG-B TTL
- 1pps voltage level: TTL level (+5 V)
- Time code telegram: RS232 (GPS)
DC level shift (IRIG-B)
- AM analogue input: IRIG-B AM modulated
- Carrier frequency: 1 kHz
- Input impedance: 600 Ohms
- Amplitude: 2.5VP-Pmin, 8VP-Pmax
- Modulation ratio: 3:1 – 6:1

COMMUNICATION

- COM1: Ethernet (RJ45)& USB (USB-B): Modbus, DNP 3.0, IEC 61850 ed.2
- COM2: RS232/RS485 Serial communications if other time synchronization modes are in use: Modbus, DNP 3.0
- Baud rate up to 115200 bps

MECHANICAL

- Dimensions: 144 × 144 × 100 mm
- Mounting: Panel mounting 144×144 mm
- Required mounting hole: 137 × 137 mm
- Enclosure material: PC/ABS
- Flammability: Acc. to UL 94 V-0
- Weight: 550 g
- Enclosure material: PC/ABS, Acc. to UL 94 V-0

ENVIRONMENTAL

- Ambient temperature: K55 temperature class Acc. to EN61557-12 (-10 ... 55 °C)
- Storage temperature: -40 to +70 °C
- Average annual humidity: ≤ 90 % r.h. (no condensation)
- Pollution degree: 2
- Enclosure protection: IP 40 (front plate), IP 20 (rear side)
- Installation altitude ≤ 2000 m

COMPLIANCE

- Refer to manual for complete standards listing
- CE Marked
- IEC 60068-2-1/-2/-6/-27/-30: Environmental testing (-1 Cold, -2 Dry heat, -30 Damp heat, -6 Vibration, -27 Shock)
- IEC 61010-1: Safety requirements for electrical equipment for measurement, control and laboratory use
- IEC 61557-12: Electrical safety in LV distribution systems up to 1kV a.c. and 1.5kV d.c. – Combined performance measuring and monitoring devices for electrical parameters
- IEC 61000-4-30 ed. 3: Electromagnetic compatibility (EMC) – Power quality measurements methods
- IEC 61000-4-7 + A1: Electromagnetic compatibility (EMC) – General guide on harmonics and interharmonics measurements
- IEC 61000-4-15: Electromagnetic compatibility (EMC) – Flicker meter
- IEC 62053-22: Electricity metering equipment - Static meters for active energy (classes 0,2 S and 0,5 S)
- IEC 62053-24: Electricity metering equipment - Static meters for reactive energy (class 0,5 S)
- IEC 62053-31: Electricity metering equipment Particular requirements - Part 31: Pulse output devices for electromechanical and electronic meters (two wires only)
- IEC 61326-1: EMC requirements for electrical equipment for measurement, control and laboratory use
- IEC 60529/A1: Degrees of protection provided by enclosures (IP code)
- UL 94: Tests for flammability of plastic materials for parts in devices and appliances
- EN 50160: Voltage characteristics of electricity supplied by public distribution networks
- IEEE 1159-3: Recommended Practice for the Transfer of Power Quality Data (PQDIF)
- IEEE C37.111: Standard Common format for Transient Data Exchange (COMTRADE) for power systems

SAFETY

- Protection: protection class II, functional earth terminal must be connected to earth potential
- Voltage inputs via high impedance
- Double insulation for I/O ports and COM ports
- Pollution degree: 2
- Installation category: CAT III ; 600 V
- Measuring inputs: CAT IV ; 300 V, Acc. to EN 61010-1

Ordering Codes

M365	*	*	*	*	*	*	*	*	*	Description
Display	A									0A iSTAT M365A EN50160 PQ Analyser - TFT 5.7" display
	B									0A iSTAT M365B EN50160 PQ Analyser - Graphic 128x64 pixel display
Nominal Frequency		S								50/60 Hz
Power Supply		A								400 Hz
Communications			H							Universal High (80 ... 300 VDC, 80 ... 276 VAC)
I/O Module 1/2				E						Ethernet (RJ45) + USB 2.0 (type B) – Modbus, DNP, FTP
				S						Ethernet (RJ45) + USB 2.0 (type B) – Modbus, DNP, FTP, IEC 61850
					A					2 x Analogue output (0 ... 20 mA)
					S					2 x Pulse output (40 Vac/dc @ 30 mA Max)
					M					2 x Relay (alarm output)(230 Vac/dc ± 20% @ 1 A Max)
					B					Bistable alarm output
					C					2 x Analogue Input - current (-20 ... 0 ... 20 mA)
					U					2 x Analogue Input - voltage (-10 ... 0 ... 10 V)
					R					2 x Analogue input - resistance (Pt100 - Pt1000)
					D					2 x Digital Input (230 Vac/dc ± 20%)
					E					2 x Digital Input (110 Vac/dc ± 20%)
					F					2 x Digital Input (5 ... 48 Vdc)
					P					2x Pulse input (5 ... 48 VDC)
					T					2 x Tariff Input (230 Vac/dc ± 20%)
					Z					2 x Tariff Input (110 Vac/dc ± 20%)
					Y					2 x Tariff Input (5 ... 48 Vdc)
					W					1 x Watchdog + 1 x Relay (alarm) output (230 Vac/dc ± 20% @ 1 A Max)
					N					Not Fitted
I/O Module 3/4					A					2 x Analogue output (0 ... 20 mA)
					S					2 x Pulse output (40 Vac/dc @ 30 mA Max)
					M					2 x Relay (alarm output)(230 Vac/dc ± 20% @ 1 A Max)
					B					Bistable alarm output
					C					2 x Analogue Input - current (-20 ... 0 ... 20 mA)
					U					2 x Analogue Input - voltage (-10 ... 0 ... 10 V)
					R					2 x Analogue input - resistance (Pt100 - Pt1000)
					D					2 x Digital Input (230 Vac/dc ± 20%)
					E					2 x Digital Input (110 Vac/dc ± 20%)
					F					2 x Digital Input (5 ... 48 Vdc)
					P					2x Pulse input (5 ... 48 VDC)
					N					Not Fitted
I/O Module A						M				8 x Relay (alarm output) (230 Vac/dc ± 20% @ 100 mA Max)
						D				8 x Digital Input (230 Vac/dc ± 20%)
						E				8 x Digital Input (110 Vac/dc ± 20%)
						F				8 x Digital Input (5 ... 48 dc)
						N				Not Fitted
I/O Module B							D			8 x Digital Input (230 Vac/dc ± 20%)
							E			8 x Digital Input (110 Vac/dc ± 20%)
							F			8 x Digital Input (5 ... 48 dc)
							N			Not Fitted

GEGridSolutions.com

IEC is a registered trademark of Commission Electrotechnique Internationale. IEEE is a registered trademark of the Institute of Electrical Electronics Engineers, Inc. Modbus is a registered trademark of Schneider Automation. NERC is a registered trademark of North American Electric Reliability Council. NIST is a registered trademark of the National Institute of Standards and Technology.

GE, the GE monogram, Multilin, FlexLogic, EnerVista and CyberSentry are trademarks of General Electric Company. GE reserves the right to make changes to specifications of products described at any time without notice and without obligation to notify any person of such changes.

Copyright 2020, General Electric Company. All Rights Reserved.

GEA-33176-(E)
English
201208

