



Time-overcurrent protection of AC circuits and apparatus.

Features and Benefits

- 6 inverse time/current operating curves
- Instantaneous current ranges
- Extended time current ranges
- Target seal-in units available
- Instantaneous units available
- High seismic capability
- Molded drawout case with clear cover

Applications

- Feeder, AC machines and transformers
- Inverse time/current applications

Protection and Control

- Ground and phase time O/C and U/C
- Overload motor protection
- Instantaneous overcurrent (optional)



Introduction

IFC relays feature compact size, visible CT shorting, improved testing and extended time and instantaneous current ranges. The IFC is available in 50 and 60 Hz models with the following time-current characteristics:

- Inverse
- Very Inverse
- Extremely Inverse
- Inverse LongTime
- Inverse MediumTime
- Inverse ShortTime

An instantaneous overcurrent unit is available.

Description

IFC relays are used for the protection of industrial and utility power systems against either phase or ground overcurrent. They are single-phase, non-directional, current sensitive ac devices. The basic operating mechanism (the time unit) produces one of several available operating characteristics with operating time inversely related to operating current to permit coordination with other protective devices. It consists of a magnetic-core operating coil, an induction disk, damping magnet, and a mechanical target. The IFC relay may also include a hinged-armature instantaneous overcurrent unit with its own target.

The IFC relay is mounted in a drawout case, permitting front access with the cover off or removal from the case for testing and maintenance. The drawout element consists of a one-piece, molded support structure on which relay subassemblies are mounted. The case, also a one-piece, glass-filled polyester molding, is suitable for either semi-flush or surface mounting. The cover is completely transparent, permitting visual inspection of the relay and determination of CT shorting bar and relay target

position.

The time-overcurrent unit has a pickup current range of 0.5-4 A or 1-12 A. The associated target and seal-in unit is dual rated for 0.2 or 2 A, and has high seismic capability.

The instantaneous unit is a hinged-armature relay with high seismic capability. A sliding link selects the upper or lower portion of the 2-50 A or 6-150 A range of setting adjustment.

Applications

IFC relays are used for protection of feeders, transmission lines, AC machines, transformers and for numerous other applications where an operating time inversely related to operating current is required.

Six inverse time/current operating characteristics are available with the IFC (see Figure 1), as follows:

EXTREMELY INVERSE TIME relays (IFC77) are intended for applications, such as on utility distribution feeders, where sufficient time delay must be provided to allow a re-energized circuit to pick up without unnecessary tripping during the inrush period, and at the same time coordinate properly with power fuses and fuse cutouts.

VERY INVERSE TIME relays (IFC53) are best applied on systems where the magnitude of the short circuit current flowing through any given relay is dependent mainly upon the relative location of the fault with respect to the relay and only slightly or not at all upon the system generating capacity.

INVERSE TIME relays (IFC51) are generally applied where the short-circuit current magnitude is dependent largely upon the system generating capacity at the time of the fault.

INVERSE LONG TIME (IFC66) relays are designed for applications requiring long time delay. One major application is in the overcurrent protection of large motors.

MOTOR PROTECTION RELAYS provide overcurrent protection for starting, overload, and fault conditions. The IFC66K relay has an inverse long time characteristic (as described above) which approximates the motor thermal limit, and two instantaneous overcurrent units. The first instantaneous unit is set above the maximum motor starting current and protects for fault conditions only. The second, a special high dropout unit, is customarily used for supervising the time overcurrent unit to permit tripping for stall and heavy overload conditions. Operation of only the time unit indicates a light or moderate overload condition and can be used as an alarm.

INVERSE MEDIUM TIME relays (IFC57) are used as generator or transformer neutral relays or as backup protection for feeder ground faults. Also, the inverse medium time relay may be used where a slower relay is required to obtain coordination.

INVERSE SHORT TIME relays (IFC95) are used on equipment where tripping must be relatively fast but should not approach the operating time of an instantaneous unit.

Fig. 1. Typical operating characteristics at 60 Hz IFC relays. The No. 5 time-dial setting is shown for each curve, and the range of time adjustment from 0.5 to 10 time-dial settings is shown for the extremely inverse, and the inverse long time relays.

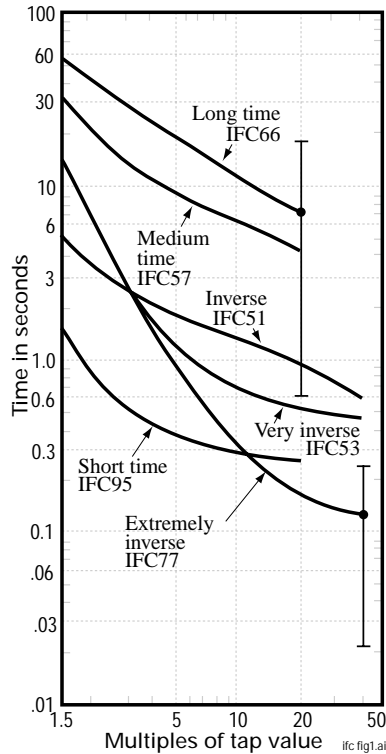

Design Features

SMALLER SIZE: The IFC is smaller in both height and width than the IAC and takes up 25 percent less panel space.

LOWER INVENTORY: Relay selection is simpler and there are fewer models to stock due to the IFC's extended time and instantaneous ranges.

EASIER MAINTENANCE: All live parts are recessed. CT shorting contacts are located at the front and are clearly visible. Case and relay support structure are molded from insulating glass-filled polyester. The IFC is recognized under the Component Program of Underwriters' Laboratories, Inc.

IMPROVED TESTING: The connection feature and test probes make IFC testing easier and more flexi-

ble. Time-current characteristics are not changed by removing the relay from its case. Refer to the GE Power Management CD or Home Page for information on test probes and plugs.

RETAINS IAC FEATURES: IFC relays use the simple, reliable induction disk principle in a fully-drawout construction. External terminal connections are identical. Performance characteristics and application criteria are the same.

SEALED CASE: A one-piece, seamless molded case with hooded flange and positive gasket seal provides superior protection in dirty or corrosive environments.

HIGH-SEISMIC CAPABILITY: Seismic Fragility Level exceeds maximum acceleration of 4g ZPA (10g peak) when tested using a biaxial, multi-frequency input.

Output Contact Arrangements

*Note: The electrically separated second contact associated with the seal-in unit will operate only when the main unit's (TOC unit) contact closes and the target seal-in unit draws trip current. Thus, the second contact should be used for alarm purposes only.

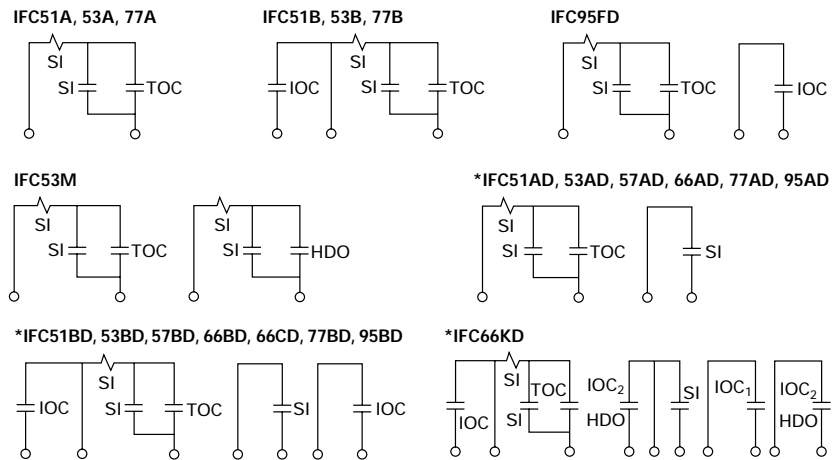

LEGEND:
 TOC = Time-overcurrent Unit
 IOC = Instantaneous Unit
 SI = Seal-in Unit
 HDO = High Dropout Instantaneous Unit

Available Settings

Time-Overcurrent Units

Range (A)	Taps (A)
0.15-1.2	0.15, 0.2, 0.25, 0.3, 0.4, 0.5, 0.6, 0.7, 0.8, 1.0, 1.2
0.5-4.0	0.5, 0.6, 0.7, 0.8, 1.0, 1.2, 1.5, 2.0, 2.5, 3.0, 4.0
1-12	1.0, 1.2, 1.5, 2.0, 2.5, 3.0, 4.0, 5.0, 6.0, 7.0, 8.0, 10.0, 12.0
1.5-6.0	1.5, 2.0, 2.5, 3.0, 4.0, 5.0, 6.0
2.5-7.5	2.5, 2.8, 3.0, 3.5, 4.0, 4.5, 5.0, 6.0, 6.5, 7.5

Instantaneous Units:

Pick-up setting is continuously adjustable over the entire range.

Operating Coil Ratings

Note that relays with both TOC and instantaneous units are limited to the lesser of the respective current ratings, since the operating coils are connected in series.

Instantaneous Unit

Rating (A)	Range Conn. of Unit	Range ① (A)	Continuous Rating (A)	One-Second Rating (A)
1.5-5.0	—	1.5-5.0	4.8	130
2-8 ① (IFC66KD only)	Lower	2-4	3.7	130
	Upper	4-8	4.8	
2-8 ①	Lower	2-4	1.9	70
	Upper	4-8	3.0	
2-50	Lower	2-10	3.5	130
	Upper	10-50	8.0	
4-16 ①	Lower	4-8	4.3	140
	Upper	8-16	6.9	
6-150	Lower	6-30	8.0	260
	Upper	30-150	18.0	
10-40 ①	Lower	10-20	9.0	275
	Upper	20-40	16.2	
20-80 ①	Lower	20-40	12.6	275
	Upper	40-80	20.0	

① This range is approximate, which means that 6-30 and 30-150 might actually be 6-28 and 28-150. However, there is at least a 1 A overlap between the maximum "Low" setting and the minimum "High" setting.

Time-Overcurrent Unit

Tap Setting	IFC51		IFC53			IFC57		IFC66	IFC77		IFC95		
	0.5-4.0 Tap	1-12 Tap	0.15-1.2 Tap	0.5-4.0 Tap	1-12 Tap	0.5-4.0 Tap	1-12 Tap	2.5-7.5 Tap	0.5-4.0 Tap	1-12 Tap	0.5-4.0 Tap	1-12 Tap	1.5-6.0 Tap

CONTINUOUS CURRENT RATING (A)

0.15			1.3										
0.2			1.4										
0.25			1.5										
0.3			1.6										
0.4			1.7										
0.5	1.6		1.9	3.8		2.3			2.5		1.2		
0.6	1.8		2.0	4.0		2.5			2.7		1.4		
0.7	2.0		2.1	4.2		2.7			3.0		1.5		
0.8	2.1		2.2	4.4		2.9			3.2		1.6		
1.0	2.3	2.7	2.4	4.7	6.8	3.3	3.9		3.6	5.8	1.9	2.0	
1.2	2.7	4.1	2.5	5.0	7.1	3.6	4.3		4.0	6.4	2.1	2.3	
1.5	3.0	4.6		5.3	7.7	4.1	4.8		4.5	7.2	2.4	2.7	3.0
2.0	3.5	5.3		5.8	8.3	4.7	5.3		5.2	8.4	2.9	3.3	3.5
2.5	4.0	6.0		6.2	8.8	5.3	6.2	5.0	5.9	9.4	3.3	3.9	4.0
2.8								5.3					
3.0	4.5	6.5		6.6	9.4	5.8	6.8	5.5	6.5	10.4	3.7	4.5	4.4
3.5								5.8					
4.0	5.0	7.6		7.1	10.3	6.8	7.8	6.1	7.5	12.1	4.5		5.3
4.5								6.4					
5.0		8.5			11.0		8.8	6.8		13.6		6.6	6.0
5.5								7.0					
6.0		9.3			11.6		9.7	7.3		15.1		7.5	7.0
6.5								7.5					
7.0		10.0			12.4		10.4			16.4		8.4	
7.5								8.0					
8.0		10.8			12.6		11.1			17.6		9.3	
10.0		12.1			13.5		12.4			19.8		10.9	
12.0		13.2			14.4		13.6			21.8		12.5	

ONE-SECOND CURRENT RATING (A)

All	128	260	60	140	260	128	260	260	84	220	82	164	246
-----	-----	-----	----	-----	-----	-----	-----	-----	----	-----	----	-----	-----

Order Code Breakdown

IFC ** ****

IFC		
51	Inverse Time	
53	Very Inverse Time	
77	Extremely Inverse Time	
95	Short Time	
57	Medium Time	
66	Long Time	
XXXX	Electrical data (see group column under selection guide)	



Selection Guide

0.2/2.0 A Target and Seal-in

15

Time Curve	Group	Time Unit	Instantaneous Unit	Case	Approx. Wt. in lbs (kg)	
					Net	Ship

60 Hz, 1 N.O. CONTACT

51	A1A	1-12	----			
51	A2A	0.5-4	----			
51	B1A	1-12	6-150			
51	B2A	0.5-4	2-50			
53	A1A	1-12	----			
53	A2A	0.5-4	----			
53	A6A	0.15-1.2	----			
53	B1A	1-12	6-150			
53	B2A	0.5-4	2-50			
53	B3A	1-12	2-50			
53	M1A	0.5-4	2-8 ①	C1	8 (3.6)	14 (6.3)
53	M2A	0.5-4	4-16 ①			
53	M3A	0.5-4	10-40 ①			
53	M4A	0.5-4	20-80 ①			
53	M5A	1-12	2-8 ①			
53	M6A	1-12	4-16 ①			
53	M7A	1-12	10-40 ①			
53	M8A	1-12	20-80 ①			
77	A1A	1-12	----			
77	A2A	0.5-4	----			
77	B1A	1-12	6-150			
77	B2A	0.5-4	2-50			
77	B3A	1-12	6-150			

60 Hz, 2 N.O. CONTACTS (SEE SECTION, OUTPUT CONTACT ARRANGEMENT)

51	AD1A	1-12	----			
51	AD2A	0.5-4	----			
51	BD1A	1-12	6-150			
51	BD2A	0.5-4	2-50			
53	AD1A	1-12	----			
53	AD2A	0.5-4	----			
53	BD1A	1-12	6-150			
53	BD2A	0.5-4	2-50			
53	BD3A	1-12	2-50			
77	AD1A	1-12	----			
77	AD2A	0.5-4	----			
77	BD1A	1-12	6-150			
77	BD2A	0.5-4	2-50	C1	8 (3.6)	14 (6.3)
77	BD3A	1-12	2-50			
95	AD1A	1-12	----			
95	AD2A	0.5-4	----			
95	BD1A	1-12	6-150			
95	BD2A	0.5-4	2-50			
95	FD1A	1.5-6.0	1.5-5/6			
57	AD1A	1-12	-150			
57	AD2A	0.5-4	----			
57	BD1A	1-12	6-150			
57	BD2A	0.5-4	6-150			
66	AD1A	2.5-7.5	2-50			
66	BD1A	2.5-7.5	----			
66	CD1A②	2.5-7.5	6-150			
66	KD1A	2.5-7.5	6-150			

① High-dropout instantaneous unit.

② Wound shading coil on TOC unit.

Time Curve	Group	Time Unit	Instantaneous Unit	Case	Approx. Wt. in lbs (kg)	
					Net	Ship

50 Hz, 1 N.O. CONTACT

51	A4A	1-12	----			
51	A5A	0.5-4	----			
51	B4A	1-12	6-150			
51	B5A	0.5-4	2-50			
53	A1A	1-12	----			
53	A2A	0.5-4	----			
53	A6A	0.15-1.2	----			
53	B1A	1-12	6-150			
53	B2A	0.5-4	2-50			
53	B3A	1-12	2-50			
53	M1A	0.5-4	2-8 ①	C1	8 (3.6)	14 (6.3)
53	M2A	0.5-4	4-16 ①			
53	M3A	0.5-4	10-40 ①			
53	M4A	0.5-4	20-80 ①			
53	M5A	1-12	2-8 ①			
53	M6A	1-12	4-16 ①			
53	M7A	1-12	10-40 ①			
53	M8A	1-12	20-80 ①			
77	A1A	1-12	----			
77	A2A	0.5-4	----			
77	B1A	1-12	6-150			
77	B2A	0.5-4	2-50			
77	B3A	1-12	2-50			

50 Hz, 2 N.O. CONTACTS (SEE SECTION, OUTPUT CONTACT ARRANGEMENT)

51	AD4A	1-12	----			
51	AD5A	0.5-4	----			
51	BD4A	1-12	6-150			
51	BD5A	0.5-4	2-50			
53	AD1A	1-12	----			
53	AD2A	0.5-4	----			
53	BD1A	1-12	6-150			
53	BD2A	0.5-4	2-50			
53	BD3A	1-12	2-50			
77	AD1A	1-12	----			
77	AD2A	0.5-4	----			
77	BD1A	1-12	6-150			
77	BD2A	0.5-4	2-50	C1	8 (3.6)	14 (6.3)
77	BD3A	1-12	2-50			
95	AD1A	1-12	----			
95	AD2A	0.5-4	----			
95	BD1A	1-12	6-150			
95	BD2A	0.5-4	2-50			
95	FD1A	1.5-6.0	1.5-5/6			
57	AD1A	1-12	-150			
57	AD2A	0.5-4	----			
57	BD1A	1-12	6-150			
57	BD2A	0.5-4	6-150			
66	AD2A	2.5-7.5	2-50			
66	BD2A	2.5-7.5	----			
66	CD1A	2.5-7.5	6-150			
66	KD2A	2.5-7.5	6-150			