



Grid Solutions
a GE and Alstom joint venture

PROTECTION PRODUCT SOLUTIONS

MHOR 04

High speed pilot-wire feeder protection

This is a well established type of protection for feeders. It is based on the Merz-Price circulating current system and suitable for operation over privately owned two-core pilots with a relatively high core resistance (up to 1000 loop) and low intercore insulation level.

MHOR 04 feeder protection

The majority of plain feeders can be protected using this arrangement which features a unit protection scheme with no time or current grading problems, even on ring circuits.

Analog current differential schemes have the advantage that they are more tolerant of poor quality or ageing pilot wires than is the case for MODEM-based digital schemes.

The three line currents are summated to provide a single phase current for comparison over a pilot circuit.

A padding resistor is provided to adjust the pilot loop resistance to a constant value of 1000 thus ensuring that the settings remain close to the design value for all pilot circuits.

The padding resistance is set to $0.5(1000 - R_p)$ on each relay, where R_p is the pilot loop resistance in ohms.

The diodes in the circuit are arranged in such a way that for all external fault conditions the relay X is connected at the

electrical center of the pilots on one half cycle and the relay Y is connected at the electrical centre on the other half cycle. This is shown in Figure 1.

As shown in the diagram there is zero voltage developed across the relay coil for one half cycle and for the other half cycle diode D2 is reverse biased. Hence for external faults no current flows in the relay coil and the protection remains stable. For internal faults current will flow into the relay coils on successive half-cycles. Diode D3 provides smoothing for the current in the relay coil and ensures precise operation.

CUSTOMER BENEFITS

- High speed operation
- Through fault stability greater than 50 times relay rating
- Pilot circuits up to 1000 Ω 2.5 F
- Not reliant on MODEMs



TECHNICAL DATA

- Current rating (I_n) 1, 2 or 5 A
- Rated frequency 50 Hz or 60 Hz
- Current settings
Summation ratio = $1/1/N$

TYPE OF FAULT	FAULT SETTINGS		TYPE OF FAULT	FAULT SETTINGS
	(% I_n)			
	N = 3	N = 5		(% I_n)
A - N	28	18	A - B	125
B - N	32	21	B - C	125
C - N	42	25	C - A	125
			A - B - C	72

- **Operation time** 60 ms at 3 times setting
- **Through fault stability** Greater than 50 times relay rating
- **Contact rating**

Four make contacts are provided each capable of:
 Make and carry for 1 second 7500 V with maxima second of 5 A and 660 V
 Make and carry continuously 1250 VA with maxima of 5 A and 660 V
 Break AC 1250 VA with maxima of 5 A and 660 V
 AC 100 W (resistive)
 50 W (inductive L/R = 0.04s)
 with maxima of 5 A and 660 V

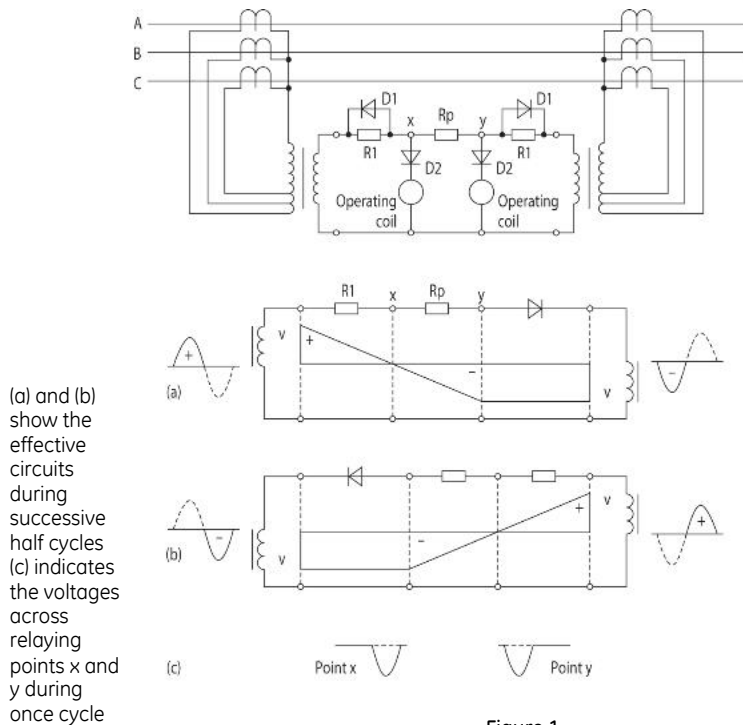

Figure 1
 Behaviour of basic MHOR 04 circuit
 under external fault conditions when $R1 = R_p$

• Current transformer requirements

Minimum knee point voltage of line CT's

$$V_k = 50/I_n + I_f (R_{CT} + 2R_L) \text{ volts}$$

where

I_n = rated current of relay (A)

I_f = fault current under maximum steady state through fault conditions, referred to the secondary circuit (A)

R_{CT} = resistance of line CT secondary winding (Ω)

R_L = resistance of a single lead from the line CT's to the relay (Ω)

The knee point voltage of a current transformer is expressed as the voltage, applied to the secondary winding with the primary on open circuit, which when increased by 10% causes the magnetizing current to increase by 50%.

It is not recommended that any other burdens should be connected in the same current transformer circuit but where this is unavoidable the additional burdens should be added into the above expression for knee point voltage.

In addition to the above the secondary magnetizing current of the current transformers at opposite ends of the feeder should not differ by more than $0.05 I_n$ at $50/I_n$ volts.

• Pilots

Any type of pilot having an insulation grade which can withstand 500 V between cores may be used. The pilots should have a loop resistance, excluding the relay, of less than 1000Ω and a total intercore capacitance of less than $2.5 \mu F$.

The pilot circuit should be capable of standing a pressure test of 5 kV rms between the two cores connected together and earth.

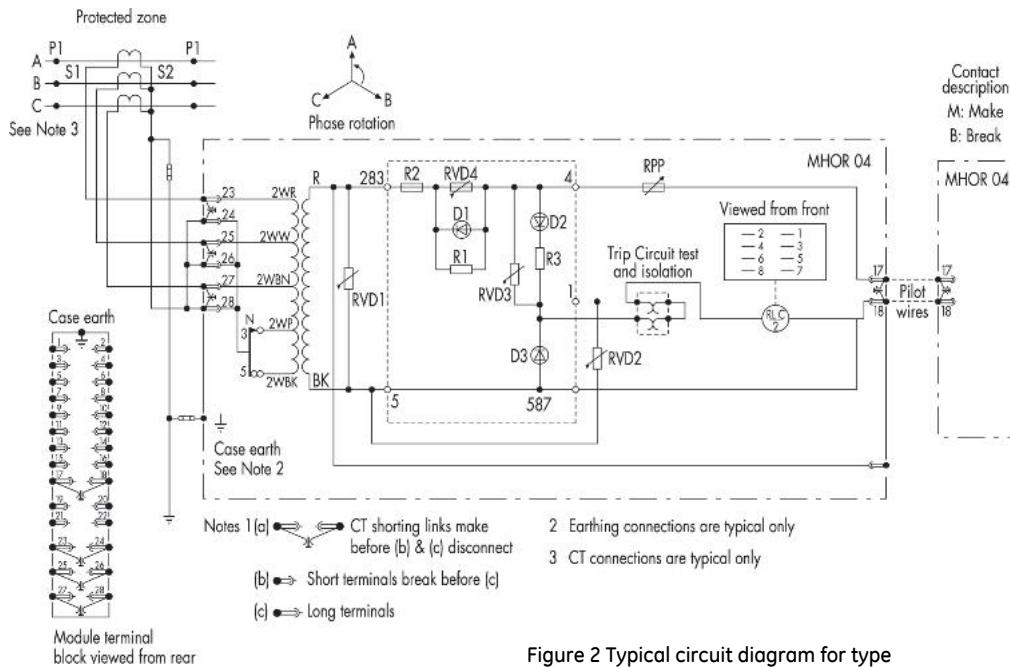

Figure 2 Typical circuit diagram for type MHOR high speed pilot wire feeder protection relay

Voltage withstand

Insulation IEC 60255 - 5

- 2 kV rms for 1 minute between all case terminals connected together and the case earth terminal.
- 2 kV rms for 1 minute between independent circuits, including contact circuits.
- 1 kV rms for 1 minute across normally open outgoing contact pairs
- 5 kV rms for 1 minute between all pilot circuits and all other circuits and the case earth terminal

High voltage impulse IEC 60255 - 5

- 5 kV peak, 1.2/50 s, 0.5 J between all terminals and case earth and between adjacent terminals

Environmental withstand

Temperature

- IEC 60068 - 2 - 1 Storage and transit -25°C to +70°C
- IEC 60068 - 2 - 2 Operating -25°C to +55°C

Humidity

- IEC 60068 - 2 - 3 56 days (@ 93% RH and +40°C)

Enclosure protection

- IEC 60529 IP50 (dust protected)

Vibration

- IEC 60255 - 21 - 21 0.5 g between 10 and 150 Hz

Mechanical durability

Loaded contact:

10,000 operations minimum

Unloaded contact:

100,000 operations minimum



Type MHOR 04: Well proven Merz-Price circulating current principle for fast unit protection using two-core pilot-wire systems

GRID SOLUTIONS' TRACK RECORD PILOT - WIRE FEEDER PROTECTION

MBCI relay launched in 1983. Over 20,000 MBCI relays delivered

MHOR 04 relays launched in 1985.

Over 10,000 MHOR 04 relays delivered

- Cases
The relay is supplied in size 6 case. The dimensions are shown in Figure 3
- Information required with order
current transformer secondary rating. Frequency rating.

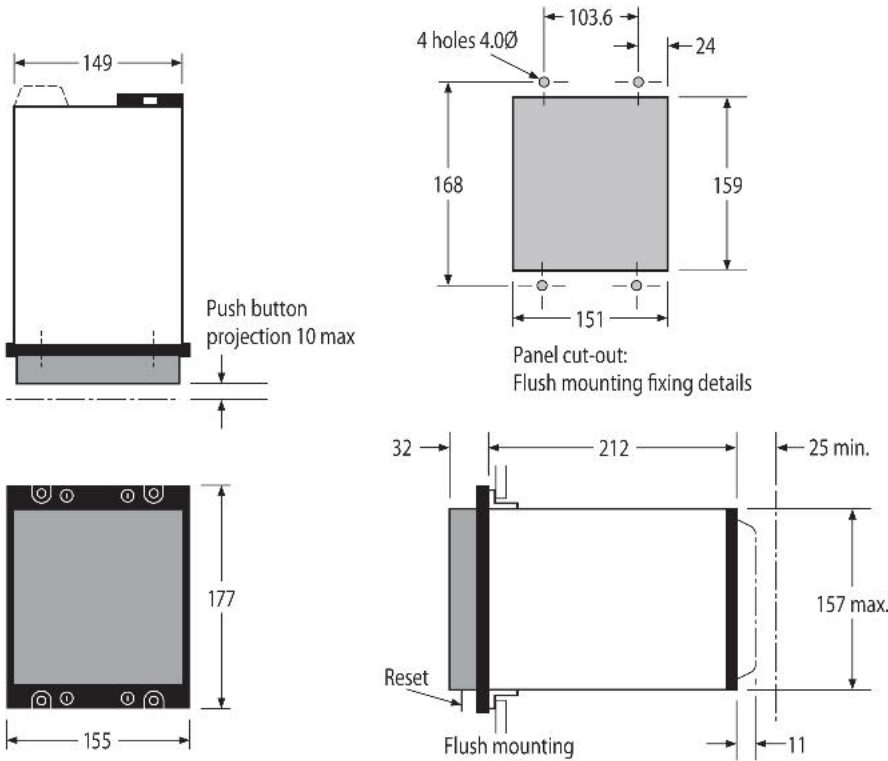

All dimensions in mm

Figure 3 Case outline size 6

For more information please contact
GE Grid Solutions

Worldwide Contact Center

Web: www.GEGridSolutions.com/contact
Phone: +44 (0) 1785 250 070

www.GEGridSolutions.com

