



HYpact

Hybrid Compact Switchgear Assembly

All in One

What is compact switchgear? HYpact is a hybrid compact switchgear assembly composed of SF₆-insulated and air-insulated components. Space and costs savings are only two of the advantages - HYpact also largely reduces switchgear exposure to environmental influences and allows for innovative and optimised substation designs.

Diversity

Endless Choices

HYpact integrates various configurations of circuit-breakers, disconnectors, earthing switches, current transformers, voltage transformers and cable connectors in one device.

Applications

Variety of Different Designs

Single line feeders, single busbar substations (including H-configurations) and double busbar substations.

Temperatures

-60 °C with pure SF₆

Low temperatures down to -60 °C with pure SF₆.
Tested according to GOST and the more exacting requirements of FGC-UES.

Seismic

0.7 g Without Fail

HYpact was exposed to shaking table tests providing a seismic capacity of up to 0.7 g.

Made by GE

HYpact is a hybrid compact switchgear assembly and HYpact consists of:

- Circuit-breakers,
- Disconnectors,
- Earthing switches
- Instrument transformers,
- Among other devices.

It is designed for the future needs of electricity networks.

Main Features

- Voltage from 72.5 kV up to 170 kV
2500 A - 40 kA - 16.7/50/60 Hz
- Completely encapsulated switchgear
- Compact design, space savings
- Temperatures down to -60 °C



Why Compact Switchgear?

In the effort to reduce space and costs, power network managers are constantly seeking new solutions for their substations. Grid Solutions, leader in both SF₆ and air insulation technologies, offers you the advantages of an innovative and compact hybrid product: HYpact.

HYpact is a range of IEC 62271-205 compact switchgear consisting of circuit-breakers, disconnectors and earthing switches. Current and voltage transformers as well as cable connectors can be added. Its modular design allows for a large variety of layout configurations.

HYpact offers more than just space savings. There are also important economic advantages to be taken into consideration: reduced space requirements are achieved by combining all the breaking and disconnecting functions into a single unit, reducing civil works expenses. The unit is also easy to transport and install, reducing engineering costs to a minimum.

HYpact: Designed and created for savings



Thanks to full SF₆ encapsulation, maintenance is simple and required at longer intervals compared to other switchgear designs.

The encapsulated design also increases operational reliability and safety under very demanding environmental conditions. HYpact is especially suited for polluted environments and extreme climates.

Grid Solutions' HYpact modules offer all the advantages of state-of-the-art switchgear: easy operation and maintenance combined with high reliability - all at a lower cost.

Grid Solutions has been manufacturing high voltage air-insulated switchgear for over 100 years. More than 120 000 products have been installed and are in service worldwide.

Our investments in R&D are significant, allowing users of our equipment to benefit from the latest technologies and innovations.

World-Class Manufacturing Facilities

Our plant in Kassel, Germany is amongst the largest and most successful production facilities in the world for high voltage products. Switchgear from Kassel is installed in both outdoor and indoor substations in more than 150 countries around the world, where they ensure an economical and reliable power supply. With our many years of switchgear manufacturing experience, we continue to supply customers throughout the world with high quality switchgear from Kassel.

With our process-oriented organisation, we react flexibly to market requirements and produce high-quality products economically and on schedule. All the products that leave our plant are distinguished by a high degree of operating safety and reliability and require only limited maintenance.

The strength of a group combining local experience and global expertise

Quality

Our markets and customers are changing fast - and so are we!
We are committed to achieving excellence in quality, which is our number one priority.

We strive for customer satisfaction through the improvement of all processes whether in terms of quality, cost or lead times. This applies to projects and administrative procedures throughout the entire business process, from tender to final delivery of our products, systems and services.

An ISO 9001-certified quality management system and ISO 14001-certified environmental management system as well as OHSAS 18001-certified occupational health and safety management systems govern the entire development and production processes for our high voltage products and ensure the highest standards of quality for all our products and services.



Research and Development

Leadership in technology is our hallmark. Year after year, GE continues to build on the technical reputation of our transmission and distribution products, services and solutions. Our international presence allows us to draw a maximum of synergies from teamwork and to engage in fruitful cooperation with local universities and scientific bodies.

GE's site in Kassel is the competence centre for circuit-breakers and compact switchgear assemblies up to 170 kV. The internationally accredited high voltage institute enables us to carry out the research and development tests required for our switchgear at the Kassel location.



Central sales office & competence centre Kassel, Germany

Advantages

Compact switchgear assemblies save space – as their name suggests. A switchyard based on hybrid compact switchgear gains more than 50 % in space savings compared to conventional open-type substations.

But space savings are only one advantage. Increasingly, operators choose HYpact even where space is ample, just to benefit from the long periods between maintenance of circuit-breakers and gas insulated disconnectors and earthing switches. Compared to conventional air-insulated substations, the maintenance-free periods of substations using HYpact are considerably prolonged.

Besides savings in space and maintenance, HYpact largely reduces the switchgear's exposure to environmental influences, thus providing an economical alternative to gas-insulated substations in places that are heavily polluted, or experience extreme weather conditions.

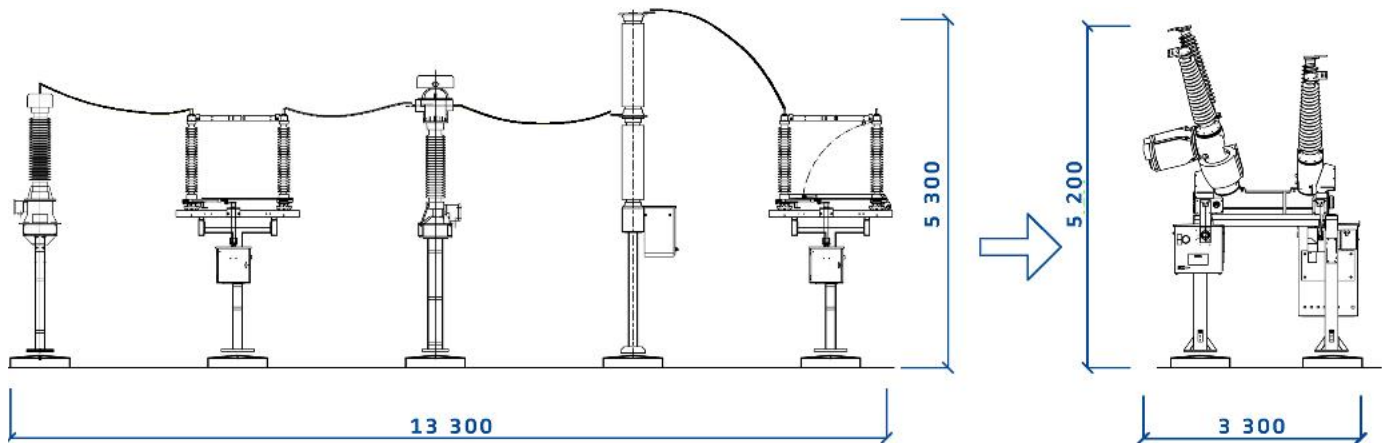

Thanks to the reduced number of components, the substation's civil works requirements, such as foundations, steel supports, cable trenches and high voltage connections are simplified. Installation works are limited to only one to two days per bay, which can often be executed without our specialised supervisors.



Single Line Feeder

Hybrid compact switchgear assemblies allow optimised substation designs that differ from conventional air or gas-insulated substation designs. Substation layouts are defined by the nature of the assembly as one unit and by the operational and maintenance requirements of the entire substation and the surrounding grid. Our experienced specialists are happy to advise you in defining your most preferred solution.

The main versions of HYpact, described in the next pages of this document, can be integrated into the following substation types (examples only):

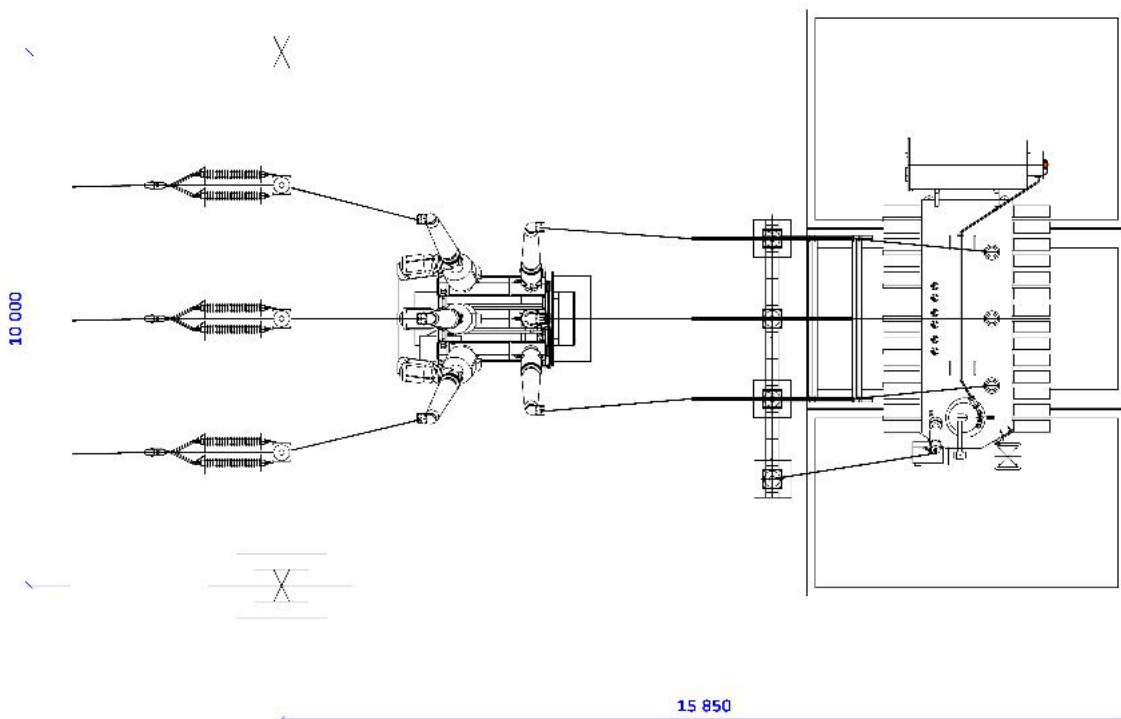
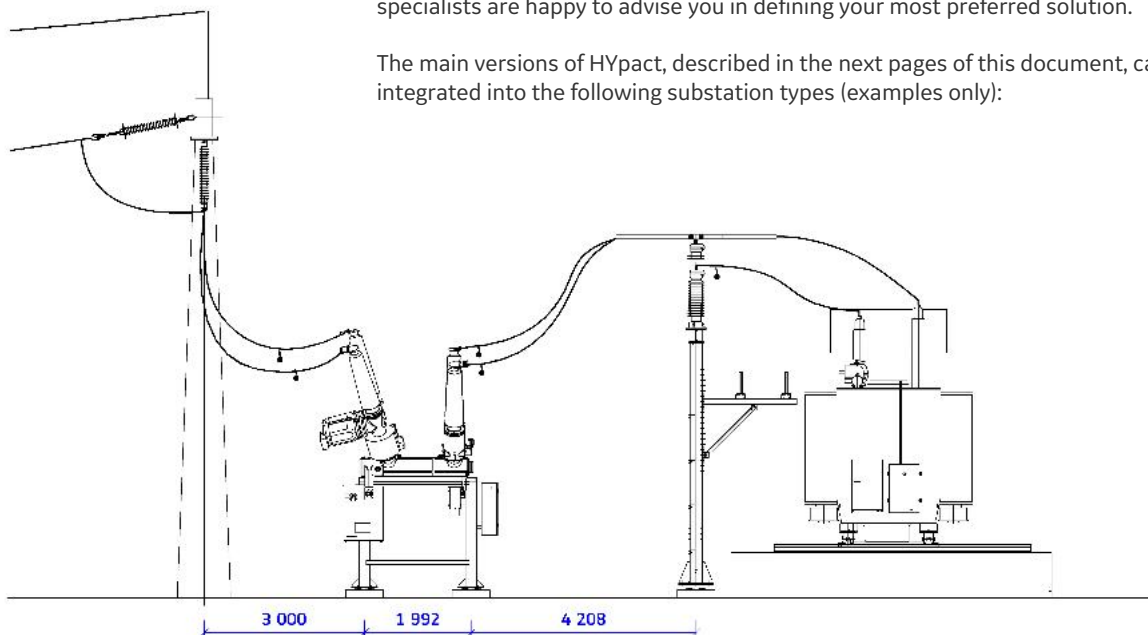

H-Schemes with two Circuit-breakers, Voltage Transformers on Busbar Side

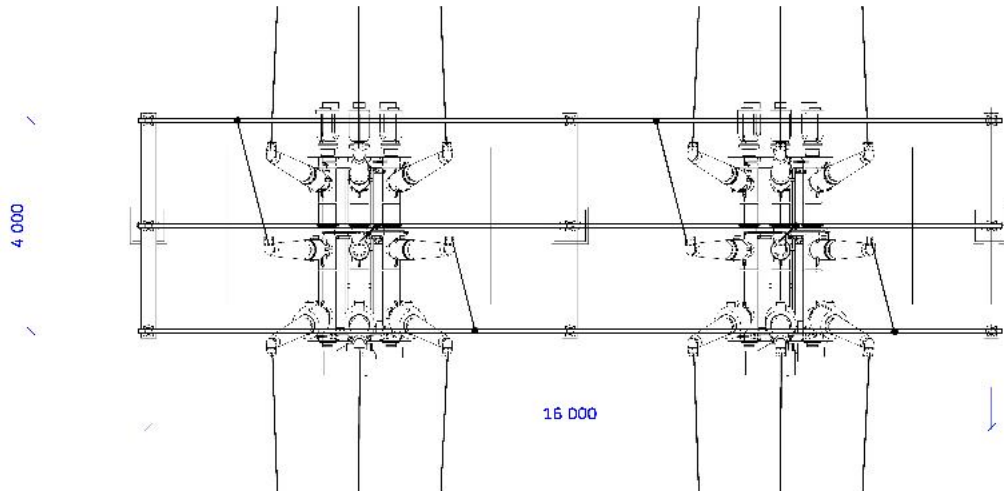

H-Schemes with Three Circuit-Breakers (switchable busbar) Extendable to Larger Single Busbar Applications

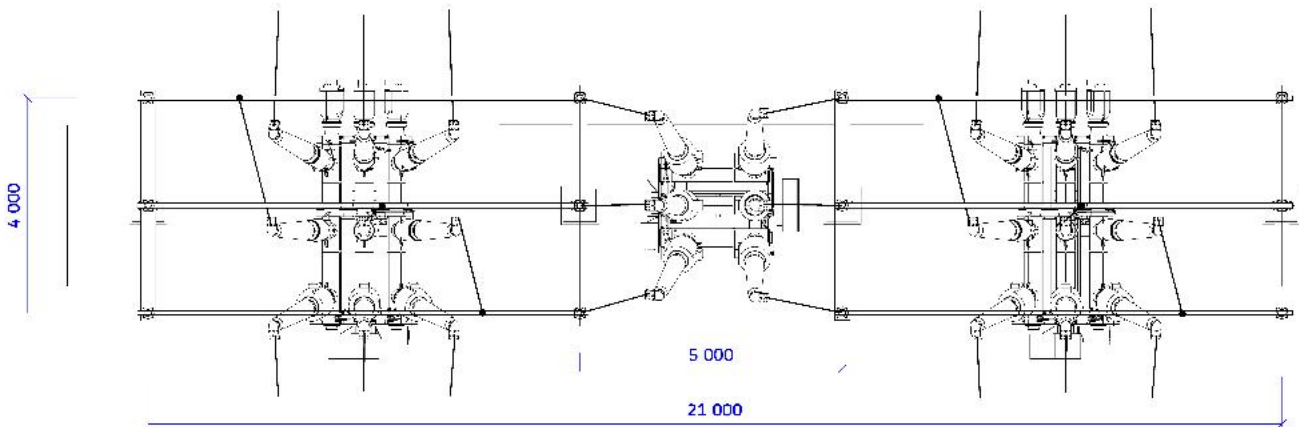

H-Schemes with Four Circuit-Breakers

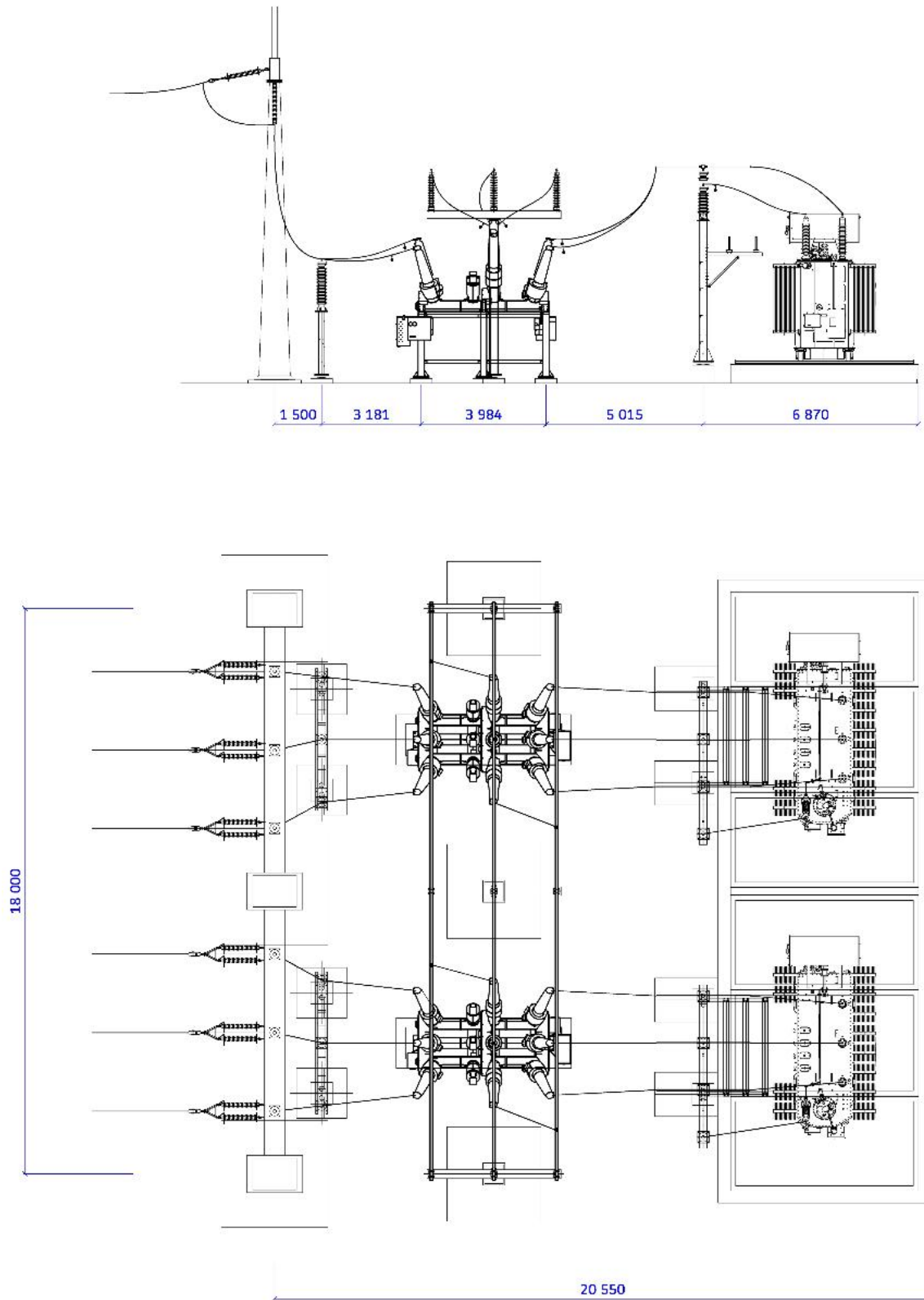

Bus Section with Bus Coupler Circuit-breaker (Incoming/Outgoing Feeder and Transformer Feeder, within One Bay Section)

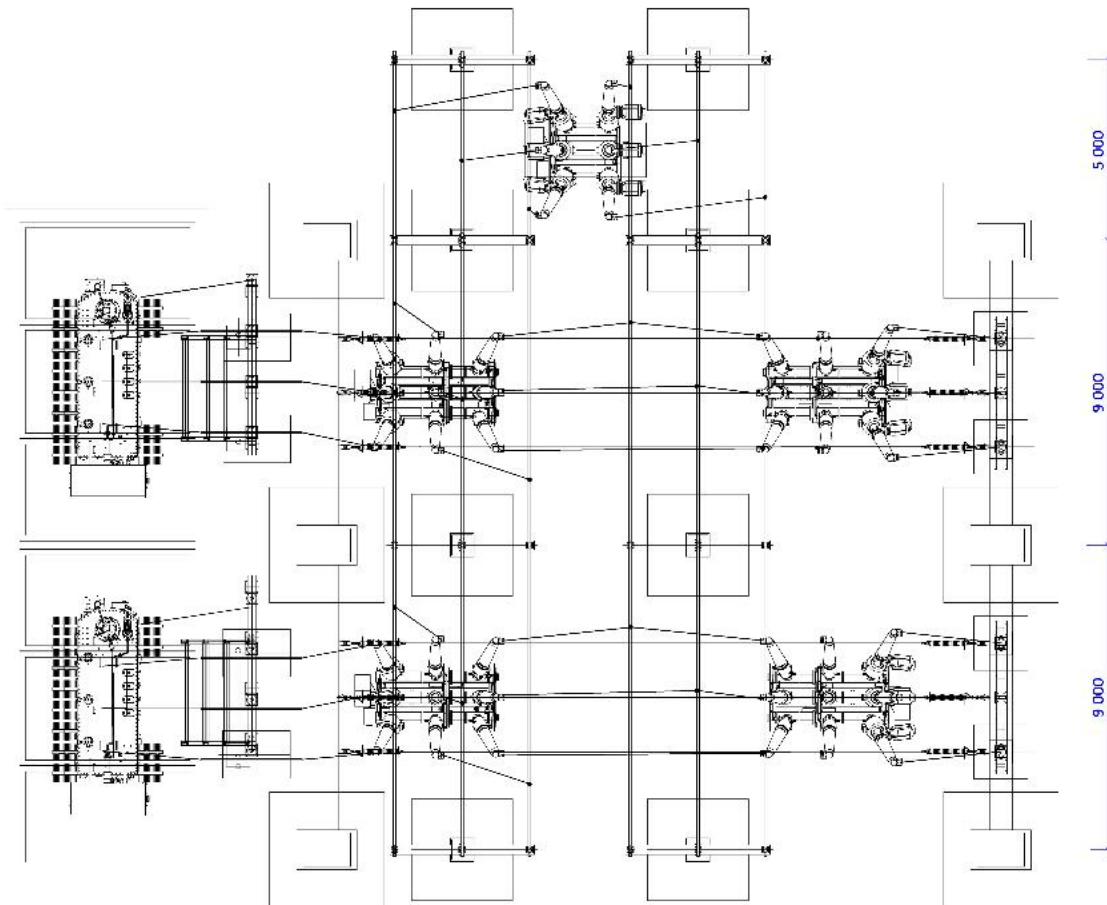
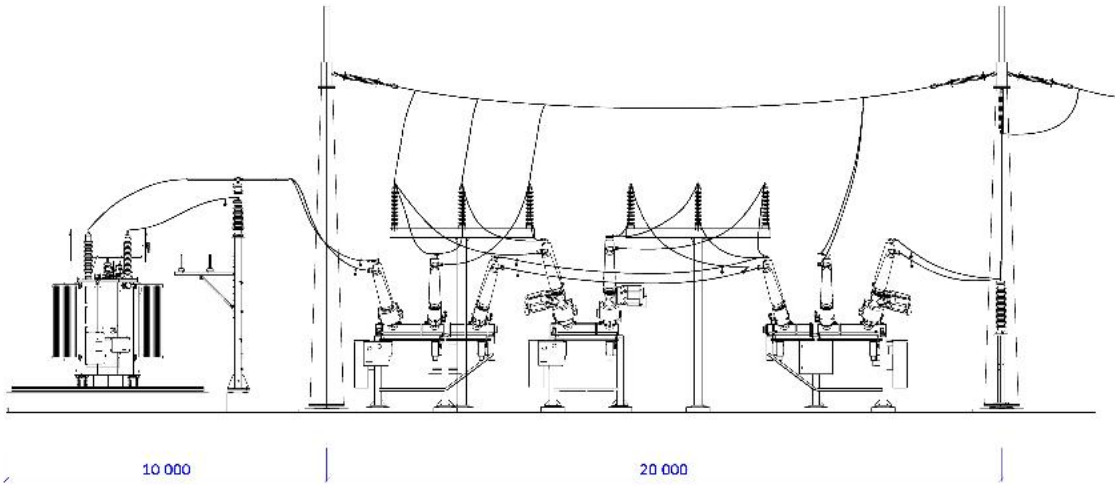

H-Schemes with Five Circuit-breakers (Switchable Busbar) Extendable to Larger Single Busbar Applications

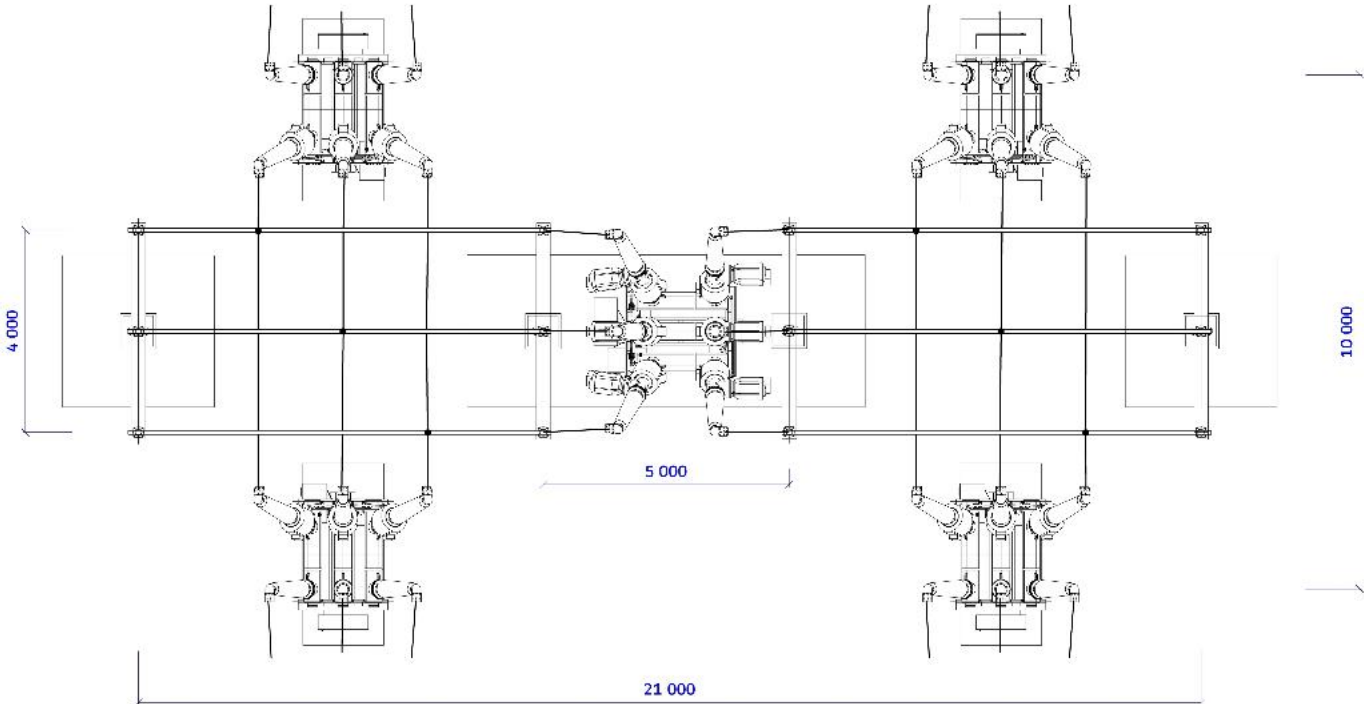

Double Busbar Section with Bus Coupler Circuit-breaker

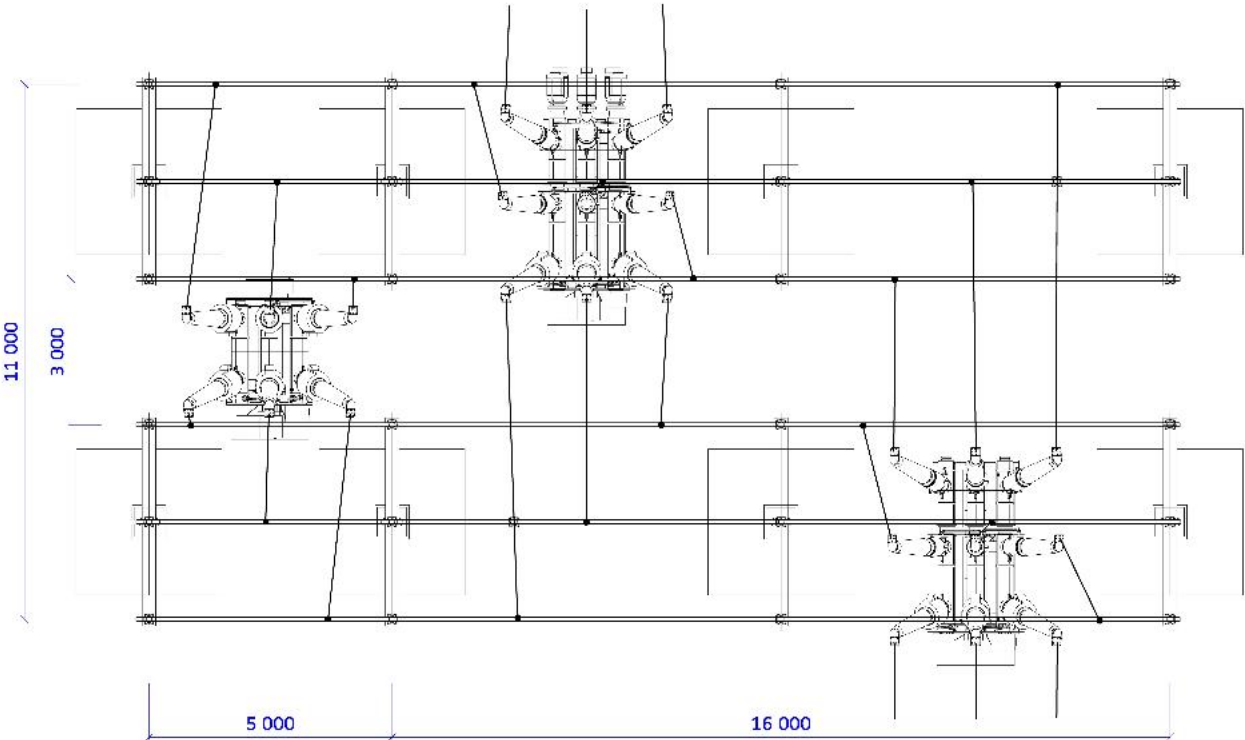

Components Overview



Circuit-breaker

Dead tank type. Three or single-phase operation.



Disconnectors/ earthing switches

Three position switch for integral or direct earthing.



Bushings

Porcelain or composite insulators. Also cable connectors.



Mechanisms

Spring-operated mechanism for circuit-breaker.
Motor operated mechanism for disconnector/earthing switch.

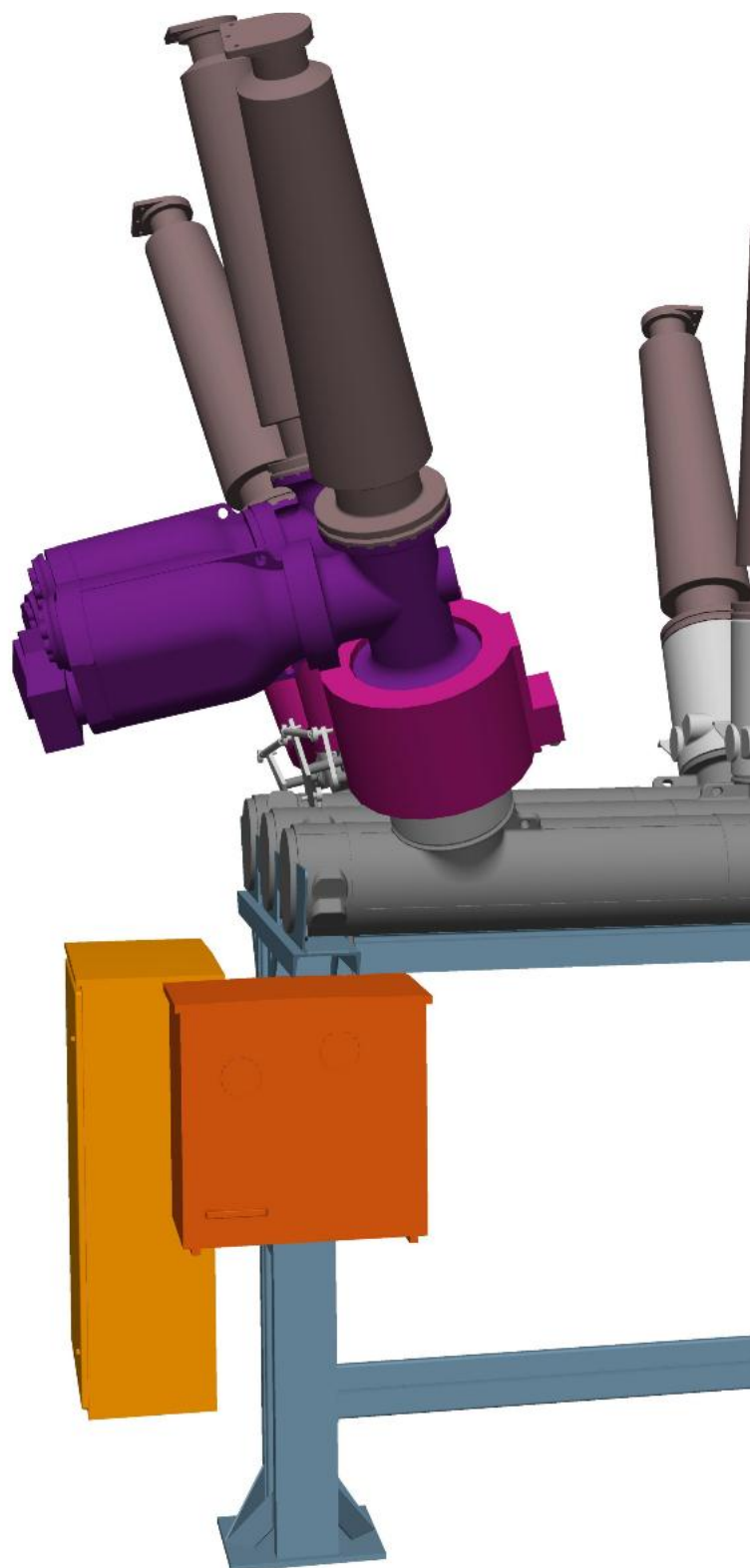

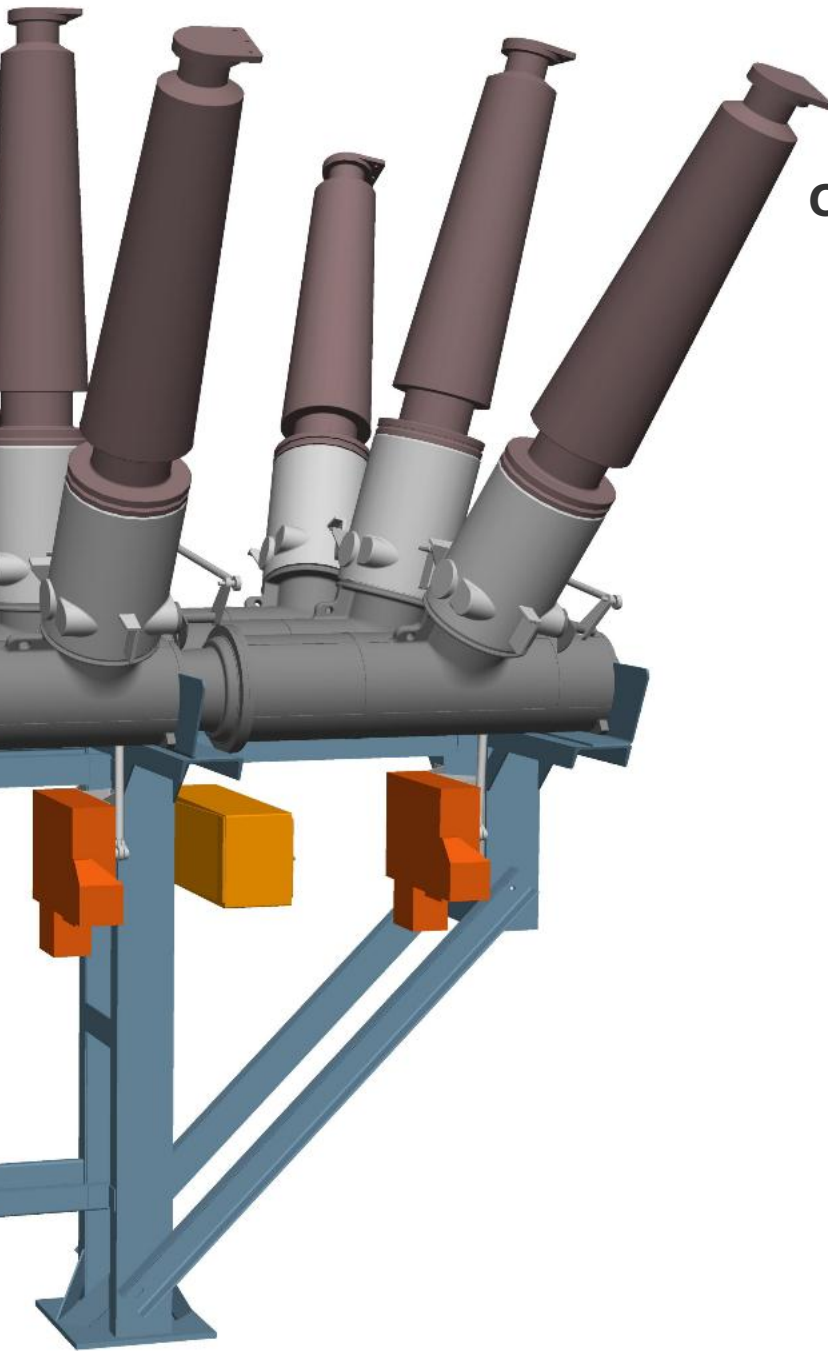

Control and transformer termination cubicles

For convenient connection of secondaries.



Current transformers

Toroidal bushing type
Cast resin or tape-air insulated.



Voltage transformers

Inductive.



Steel supports

Hot-dip galvanised.



Circuit-Breaker

The basic component of every HYpact is its single-phase encapsulated dead tank circuit-breaker. The single aluminium alloy cast housings require a minimum of gaskets, ensuring low leakage rates.

The double motion breaking chamber, also used in live and dead tank circuit-breakers, requires at least 65 % less drive energy compared to traditional self-blast thermal breaking chambers and results in considerably reduced mechanical stress on all HYpact components. Circuit-breakers are either three-pole (gang) or single-pole operated.

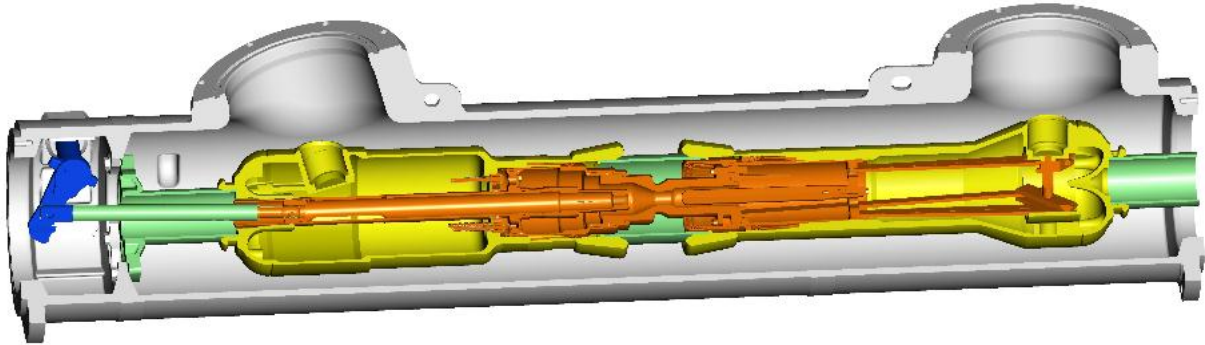

Protected Operating Linkages

The inter-phase linkages as well as linkages between drive mechanisms and switchgear can be fully covered when necessary due to environmental conditions or safety regulations.

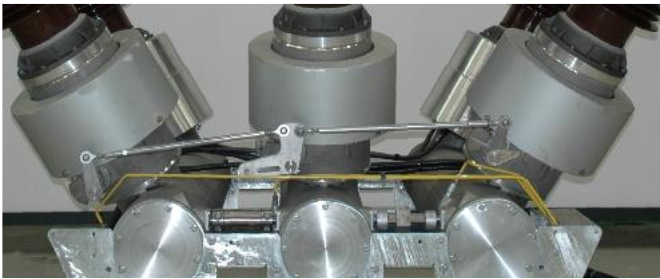

Bushings

Bushings can be supplied either as porcelain or composite bushings. The creepage distance is designed for very heavily polluted areas. (Pollution level IV according to IEC 60815.)



Disconnecter/Earthing Switches

HYpact comes with a variety of disconnecting and earthing switch options, all of which are based on gas-insulated disconnector and earthing switch technologies. The gas insulation protects the contacts from environmental influences like precipitation, pollution and ice, while its compact and encapsulated design ensures that contacts do not need to be re-adjusted due to aging or short-circuit current misalignment.

The preferred option is the combined disconnector and earthing switch, where the circuit-breaker finalises the earthing operation. The electrical stress on the earthing switch (sometimes caused by inductive currents) is diverted to the much stronger circuit-breaker, relieving the earthing switch from wear and tear and resulting in reduced maintenance requirements. This earthing principle is referred to as integral earthing and is commonly used in medium voltage technology and now increasingly in high voltage applications.

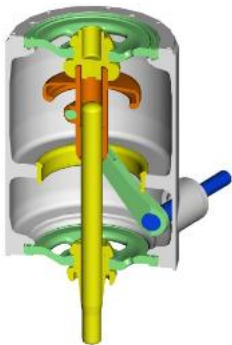

Connected
 Disconnector closed
 Earthing switch open

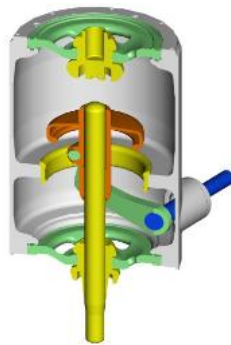

Neutral
 Disconnector open
 Earthing switch open

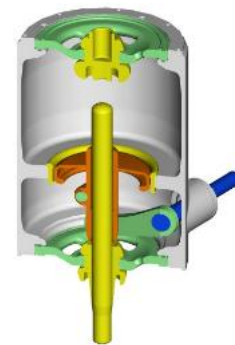

Earthing
 Disconnector open
 Earthing switch closed

The three-position switch provides a closed disconnector switch with open earthing switch, an open disconnector switch with open earthing switch and an open disconnector switch with closed earthing switch. The disconnector and earthing switches are intrinsically interlocked.

Where substation design and operational requirements do not allow for integral earthing, a direct disconnector/earthing switch is provided. Here, the earthing switch operates independently of the circuit-breaker. Induced currents can be switched according to IEC 62271-102, annex C, class B.

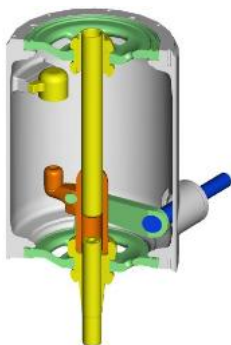

Connected
 Disconnector closed
 Earthing switch open

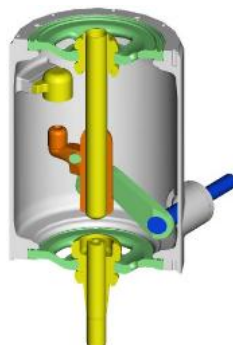

Neutral
 Disconnector open
 Earthing switch open

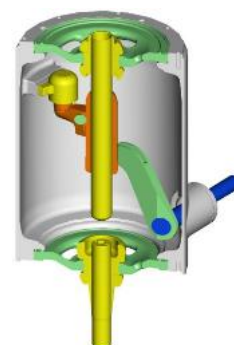

Earthing
 Disconnector open
 Earthing switch closed

When required, the disconnectors of integral disconnector/earthing switches can be reinforced with arcing contacts, enabling the disconnector to switch bus-transfer currents occurring in large air-insulated substations (1600 A - 100 V in accordance with IEC 62271-102, annex B, class B [for large air-insulated busbars]).

As a further option, fault-proof earthing switches being able to switch onto live lines are provided.

Current Transformer

Epoxy-cast resin toroidal current transformers (with or without metal covers) are placed around disconnect/earthing switches so that they do not need extra space. If located directly below the bushing, in most cases they can be slipped over the bushing so that gas works are not required if these current transformers need to be replaced.



Each current transformer can consist of up to seven cores. As the number of cores depends on the current transformer's ratio, number of taps, accuracy and power, current transformers are always defined by particular requirements.

Current transformers terminate into dedicated terminal boards located in a central instrument transformer termination box or within the central control cubicle.



Voltage Transformers

Inductive voltage transformers may be integrated. These gas-insulated voltage transformers are equipped with gas barriers to form separate gas zones. Capacitive voltage sensors are also available.



Cable Connectors and Surge Arresters

Integrated cable connectors are optionally available for several types of the most common cable connector manufacturers. Air-insulated surge arresters may be added on steel stand extensions.



Central Control

The switchgear control functions of each bay are either integrated into the drive mechanisms or provided in a separate central control cubicle. The bay control is made by means of conventional relays and contactors, though programmable logic controllers and electronic control options are alternatively available. If the bay control is integrated into the substation protection and control scheme, the switchgear control at bay level may be avoided.

Optionally, HYpact can be upgraded with intelligent circuit-breaker monitoring (CBWatch).



Indicators

The position of circuit-breaker and disconnector/earthing switches is displayed in a mechanically linked mimic diagram, conveniently visible from the HYpact's front side.



Additional precision indicators show the exact position of disconnector/earthing switches, including tolerances permitted.



Drive Mechanism

Circuit-breakers are powered by spring-operated mechanisms from Grid Solutions' FK 3-1 series. These drive mechanisms use the most reliable helical compression springs and are present in more than a hundred thousand live and dead tank circuit-breakers, gas insulated switchgear and compact switchgear assemblies worldwide.



Disconnector/earthing switches are operated by a three-position motor drive, allowing for emergency manual operation as well.



Circuit-breaker and disconnector/earthing switch drives are mounted on the steel supports and are therefore not only readily adjusted when dispatched, but also conveniently accessible for inspections or for emergency operations.

Main versions

HYpact's modular concept facilitates a variety of configurations suitable for most substation designs, of which the most prominent are shown below.

Single Busbar Versions:

HYpact for line and transformer bays:

- one circuit-breaker
- one integral disconnector/earthing switch
- current transformers on either, or on both sides

Optionally available:

- second disconnector/earthing switch (recommended for switched busbar applications and bus coupler applications)
- either disconnector/earthing switch with direct earthing
- integrated voltage transformers
- integrated cable connectors

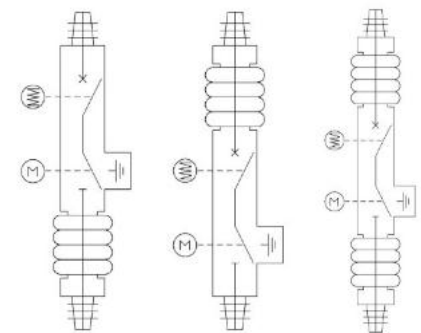

Versions for Double Busbar:

HYpact for line and transformer bays:

- one circuit-breaker
- two selector switch disconnectors, one or both as disconnector/earthing switch
- direct feeder disconnector/earthing switch
- current transformers on either bushing

Optionally available:

- without feeder disconnector/earthing switch for transformer bays
- integrated voltage transformers
- integrated cable connectors
- separate gas zones
- **reinforced arcing contacts for non-disruptive bus-transfer**

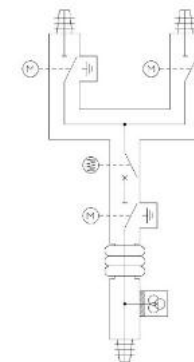

Double Circuit-Breaker Versions for H-Schemes:

HYpact for line and transformer bays:

- two three-pole-operated circuit-breakers
- three direct disconnect/earthing switches
- direct feeder disconnect/earthing switch with current transformers
- voltage transformer on busbar side

Optionally available:

- single-pole-operated circuit-breakers
- integrated voltage transformers on feeder side
- integrated cable connectors
- separate gas zones

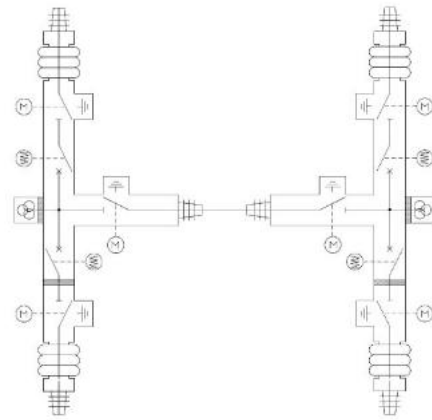

Ratings*

Type		HYpact 72.5	HYpact 123	HYpact 145	HYpact 170
Rated voltage	[kV]	72.5	123	145	170
Rated frequency	[Hz]	50/60	16.7/50/60	16.7/50/60	50
Rated power frequency withstand voltage	[kV]	140	230	275	325
- to earth	[kV]	160	265	315	375
- across the isolating distance					
Rated lightning impulse withstand voltage	[kV]	325	550	650	750
- to earth	[kV]	375	630	750	860
- across the isolating distance					
Rated normal current	[A]	2500	2500	2500	2500
Rated short-circuit breaking current	[kA]	40	40	40	40
Rated short-circuit making current	[kA]	104	104	104	100
Rated duration of short-circuit	[s]	3	3	3	3
Specific to Circuit-Breaker					
Break time	[ms]	≤60	≤60	≤60	≤60
Closing time	[ms]	≤70	≤70	≤70	≤70

* Standard values; further data available on request.

The modular concept of HYpact allows its use in almost all substation layouts including single and double busbar applications, cable connectors and single- and three-phase operation for indoor and outdoor installations.

- **Spring-operated mechanism**
FK 3-1
- **Rated operating sequence of circuit-breaker**
O-0.3s-CO-3 min-CO resp. CO-15s-CO
- **Rated supply voltage**
From 48 up to 250 Vdc/ac
- **Maximum ambient temperature**
From -60 °C up to +40 °C (with pure SF₆)

Type Tests

The IEC standard for compact switchgear assemblies, IEC 62271-205 2008, requires not only the performance of type tests for each individual device, but also the need to demonstrate the characteristics of the assembly in its entirety. Consequently, the complete HYpact consisting of circuit-breaker, disconnecter, earthing switch and current transformer undergoes an extensive type test series, including, but not limited to power tests, dielectric tests, mechanical and environmental tests.

Complete devices and functions, e.g. cable connectors or voltage transformers, are tested according to their individual applicable standards also as part of the HYpact to demonstrate that interactions between the devices and the HYpact do not limit their individual ratings or those of the entire assembly.

HYpact type tests are carried out in accredited and certified test laboratories.



Operation at low Temperatures

HYpact performs perfectly in harsh climates, even under heavy snow and ice loads, or at temperatures down to $-60\text{ }^{\circ}\text{C}$, with pure SF_6 .

Due to well-covered movable parts, HYpact is properly mechanically protected against the influence of heavy snow and ice-loads.

Additionally, a thermostat-controlled, AC-powered heating system ensures the reliable electrical operation of HYpact at temperatures lower than $-30\text{ }^{\circ}\text{C}$.

Placed at the main tanks, a number of heating pads and cartridge heaters operate independently.

Protective covers ensure all-over heat distribution and double as safety devices against unintended touching.

Gentle on energy resources, the gas volume is heated in two steps, depending on the ambient temperature. Starting from $-22\text{ }^{\circ}\text{C}$, the second circuit is energised at $-35\text{ }^{\circ}\text{C}$ for the $-45\text{ }^{\circ}\text{C}$ -application or at $-50\text{ }^{\circ}\text{C}$ for the $-60\text{ }^{\circ}\text{C}$ -application.

Tested according to the requirements of GOST 15150 and 52565, as well as according to the more harsh requirements of FGC-UES, the proper function of HYpact is ensured even in the event of loss of auxiliary power for up to two hours, down to $-60\text{ }^{\circ}\text{C}$ and under wind load.

For areas, designated for temperatures lower than $-45\text{ }^{\circ}\text{C}$, UV-protective silicone blankets are used.

Using Grid Solutions' heating system enables operation of HYpact under extremely low temperature conditions, with pure SF_6 .

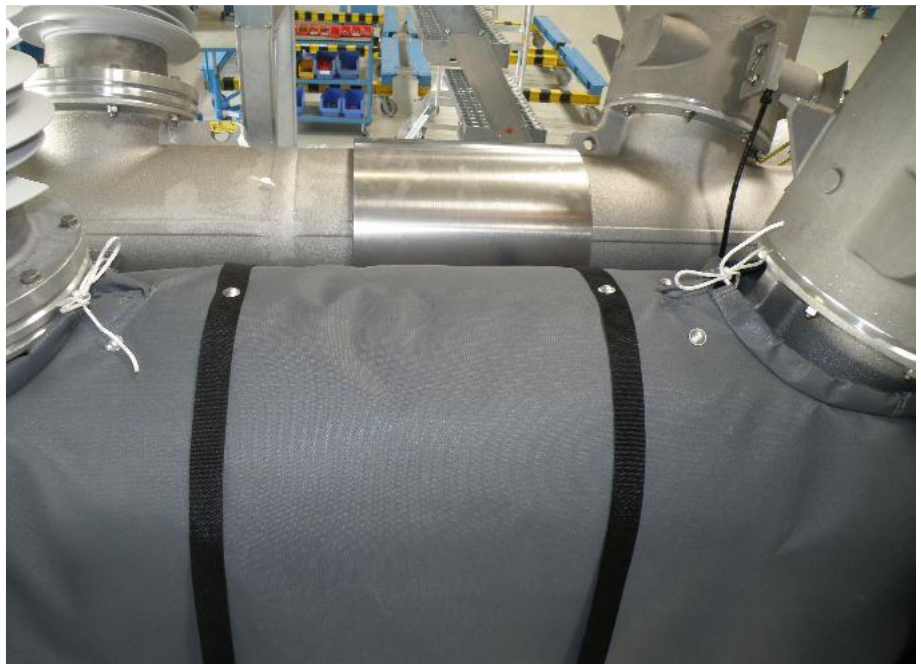

Seismic Qualifications

Thanks to its low centre of gravity and compactness, particularly of the encapsulated disconnectors and earthing switches, HYpact is the ideal switchgear for areas exposed to high seismic activity. To optimise the HYpact for use under very heavy seismic conditions, finite element method calculations are carried out. As a result, HYpact used in earthquake-prone areas are equipped with supports made of high yield-strength steel. For verification of the calculations, the HYpact is exposed to additional shaking table tests based on IEEE Std 693TM-2005 High Level, equal to seismic accelerations of 0.7 g.



HYpact under shaking table test

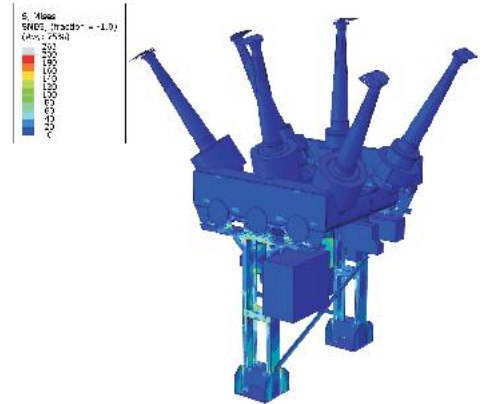

Seismic calculation

Mobile Substation

The compactness of HYpact makes it the preferred solution for mobile substations, either truck-mounted for frequent relocations, or on platforms for less frequent position changes.



Railway Applications

HYpact is also available for 16.7 Hz, 50 Hz and 60 Hz two-phase systems.



Transport and Installation

Most versions are small enough to be transported in containers or on trucks with the phases spread open for quick installation, thus saving on transport costs and installation times.



Container transport



Transport by truck

The two delivery units – two steel stands with drive mechanisms/control cubicle mounted and the switchgear module containing the circuit-breaker, disconnect/earthing switches, current transformers, voltage transformers and bushings – can be easily installed and commissioned in only one to three days per bay, without the need for time-consuming evacuation and SF₆-refilling works - and without special tools.

Monitoring

In addition to standard product components, we develop optional systems to optimise the monitoring and maintenance of high voltage equipment.

CBWatch Monitoring System

The CBWatch is a combination of new monitoring and maintenance optimisation tools accessible via web-based technology.

The CBWatch is installed in the control panel and maintains a constant, monitored link with a local or remote database via CBWatch Tool software. The monitoring system records information coming from the sensors installed on the breaker, then analyses the information, comparing it with standard operational parameters programmed into the system.



CBWatch

HYpact Around the World



Andorra



Bolivia



Bulgaria



Ecuador



Gabon



Georgia



Italy



Italy



Kenya



Romania



Russian Federation



South Africa



China



China



Czech Republic



Germany



Germany



Germany



New Zealand



Oman



Poland



Switzerland



Ukraine



United Kingdom

For more information please contact
GE Energy Connections
Grid Solutions

Worldwide Contact Center

Web: www.GEGridSolutions.com/contact
Phone: +44 (0) 1785 250 070

GEGridSolutions.com

IEC is a registered trademark of Commission Electrotechnique Internationale. IEEE is a registered trademark of the Institute of Electrical Electronics Engineers, Inc.

GE and the GE monogram are trademarks of General Electric Company.

GE reserves the right to make changes to specifications of products described at any time without notice and without obligation to notify any person of such changes.

Grid-AIS-L3-HYpact-0124-2017_03-EN. © Copyright 2017, General Electric Company. All Rights Reserved.



Imagination at work