



MULTILIN

GET-6169G

GE Power Management

SBM

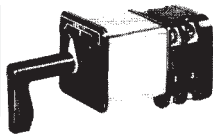

SB-1

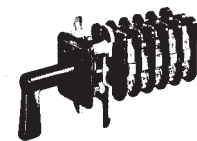

SB-9

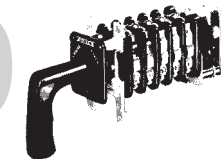

SB-10



**Selection
and
Application
Guide
for
SB Control
and
Transfer
Switches**

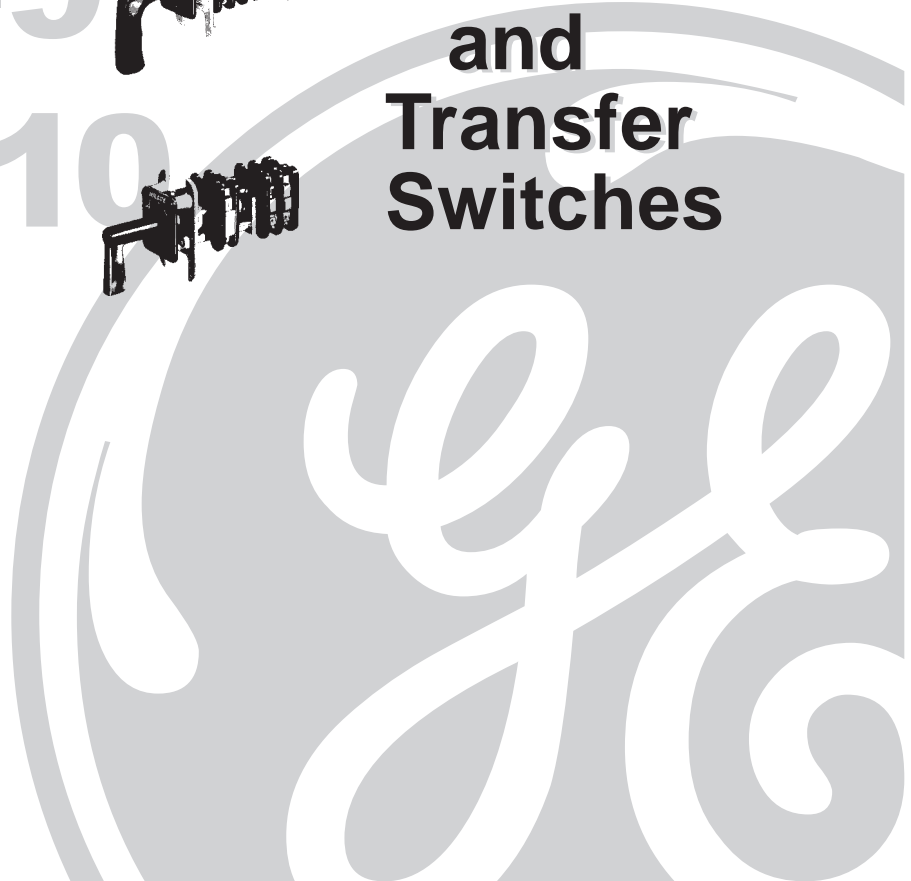

INTRODUCTION To Control and Transfer Switches

Multi stage / Versatile / Reliable

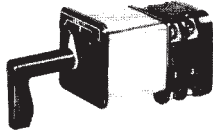

The SBM Switch

is a rotary, cam-operated, compact switch for panel mounting only. Two electrically separate and mechanically independent contacts per stage. These small, versatile switches mount close and wire easily on a switchboard. Common types are warehouse stock.

Instruction Book - GEH-2038
Renewal Parts - GEF-4167

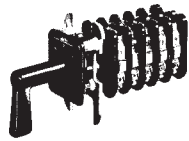

The SB-1 Switch

is a rotary, cam-operated switch, slightly larger than the SBM switch and capable of more design flexibility. It can be independently mounted and housed. Many common types are warehoused.

Instruction Book - GEH-908
Renewal Parts - GEF-2357

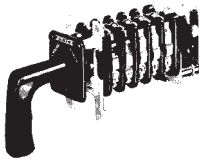

The SB-9 Switch

is a heavier-duty switch than the SB-1 and is especially designed for applications requiring unusually high numbers of repetitive operations, but otherwise similar in optional features and design capability.

Instruction Book - GEH-908
Renewal Parts - GEF-3481



The SB-10 Switch

is similar to the rotary operation of the SB-1 Switch, but the SB-10 switch has the additional capability of opening and closing contacts with a lateral push or pull of the handle.

Instruction Book - GEH-908
Renewal Parts - GEF-3482

This publication provides descriptive, technical, selection and ordering information on Control and Transfer Switches manufactured by GE Power Management.

To aid in providing the selection and specification of customer requirements, General Arrangements and Contact Diagrams are included in this publication for the various models of standard switches described above. Several standard circuits are illustrated for the common applications such as circuit breaker control and ammeter-voltmeter transfer. Select the model which applies and order by model number only, using the appropriate ordering guide. If the standard switch is satisfactory, except for some minor exception, specify the exception along with the appropriate catalog number.

If a standard model does not meet your application follow the ordering instructions given in this publication to specify the functions required, or order by "similar to . . . except (state the exception). Use one of the following forms to place your order:

Form GED-3933 . . . for SBM switches only

**Form GED-3934 . . . for SB-1, SB-9, and SB-10 switches: Part 1: Standard features
Part 2: Optional features**

For your convenience, the above GED specification forms have been reproduced in this publication and can be copied in lieu of the forms (*check Quick Reference - Page 1*).



MULTILIN

GE Power Management

PRODUCT DESCRIPTIONS & FEATURES

SBM Switch Description 2
 SBM Features 3
 SB-1 / SB-9 / SB-10 Switch Descriptions 6
 SB-1 / SB-9 / SB-10 Features 7

OPTIONAL FEATURES

Tandem Switches 10
 Lock-In Handles 10
 Palladium Contacts 10
 Pull-to-turn Handles 10
 Push-to-turn Handles 10
 Cam Action and Limitations 11
 Overlapping Contacts 13
 Removable Handles 15
 Temperature Meter Switches 17

OUTLINE DIMENSIONS

SBM Switch Dimensions 18
 SB-1 Switch Dimensions 19
 SB-9 Switch Dimensions 20
 SB-10 Switch Dimensions 21
 Tandem Switch Dimensions 22
 Locked Switch Dimensions 23

CONTACT DIAGRAMS

SBM Switch Contact Diagrams 24
 SB-1 Switch Contact Diagrams 38

GUIDES / FORMS / EXAMPLES

SBM Switch “Ordering Guide” 55
 SBM “Specification Form” (GED-3933) 56
 SBM “Form Examples” 57
 SB-1 / SB-9 / SB-10 Switch “Ordering Guide for Part 1” 59
 SBM “Specification Form” (GED-3934 - Part 1) 60
 SB-1 / SB-9 / SB-10 Switch “Ordering Guide for Part 2” 61
 SBM “Specification Form” (GED-3934 - Part 2) 62
 SB-1 / SB-9 / SB-10 “Form Examples” 63

FIELD MODIFICATION INSTRUCTIONS

SBM Switch Inspection, Changing Sequences, Slip Cams 67

NOMENCLATURE GUIDES

SBM Unlisted Switches 69
 SB-1 or SB-9 Unlisted Switches 70
 SB-1 or SB-9 2nd & 3rd Code Letters 71

A compact cam operated, positive acting switch for control and transfer service on panels and switchboards, 600 volts and under.

SBM

***Compact
Cam-operated
Switch***

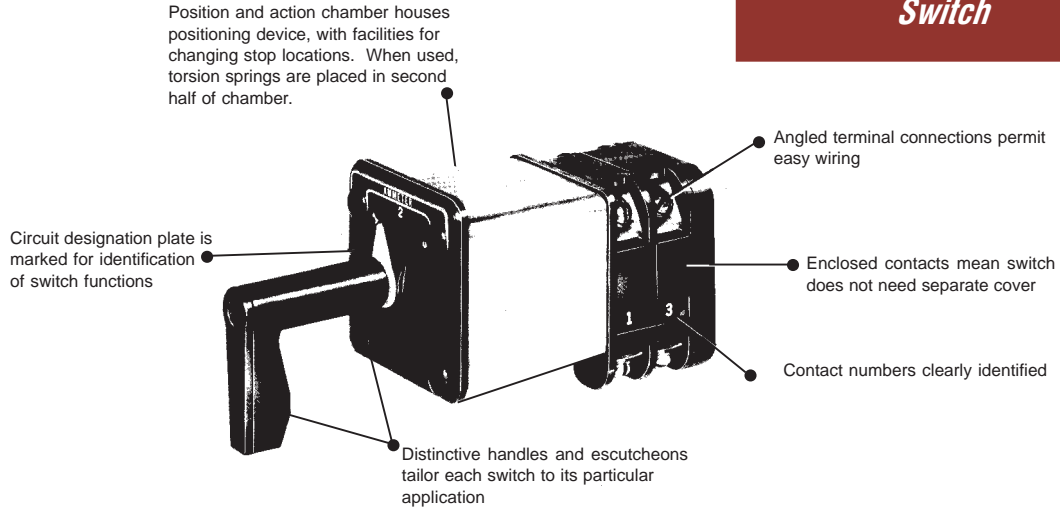

DESCRIPTION

The SBM is a compact, positive acting switch for control and transfer service on panels and switchboards, 600 volts and under. Up to 10 stages, 2 contacts per stage can be provided, with independent action, both electrically and mechanically, through eight positions.

IDEAL FOR SWITCHBOARDS

The SBM switch is especially adaptable for switchboard applications where space is at a premium.

The SBM switch is normally supplied for mounting on panels up to 1/4 inch thick. If requested, it can also be supplied for mounting on panels of one or one and a half inches.

Compact design of the SBM switch permits close center-to-center line

mounting distances and at the same time, easy access to the terminals for wiring. Also, since the switch is enclosed, there is no need for clearance at the back of the panel to remove a separate cover. This further reduces space requirements.

RATINGS

The SBM switch is rated for a mechanical life of 500,000 operations. The electrical ratings are 600 volts ac or dc, 20 amps continuous or 250 amps for three seconds. The interrupting rating depends upon the voltage and character of the circuit. The table below illustrates the interrupting duty of a single contact and contacts in series when various conditions exist on a circuit.

Table 1: Interrupting Rating in Amperes

Circuit Volts	Non-Inductive		Inductive	
	Number of Contacts			
	1	2 in Series	1	2 in Series
24 dc	10	30	8	25
48 dc	8	25	6	18
125 dc	5	15	4	10
250 dc	1	3	1	2.5
600 dc	0.4	0.8	0.3	0.7
115 ac	40	75	24	50
230 ac	25	50	12	25
450 ac	20	30	10	20
600 ac	15	25	8	12

SBM is recognized under the component program of Underwriter's Laboratories, Inc.



GE Power Management

SBM Compact Cam-operated Switch

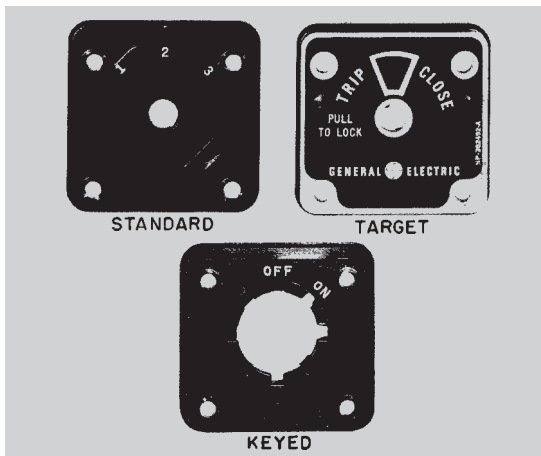

Escutcheons

Two basic types of escutcheons are available: the "**Standard Type**" shown on the top left is a molded black phenolic material with white lettering for clear reading of the positions. The "**Target Type**" escutcheon, shown on the top right, is normally furnished on breaker control switches. An aluminum front plate houses the target mechanism with a window in the center to show green for the trip position, red for the closed position, and black for the pull-to-lock position. The target has a slip action so that it will remain green when the handle returns to NORMAL from the TRIP position, and red when it returns from the CLOSE position. This indicates to the operator the last operation of the switch.

The "**Keyed Type**" shown at bottom center is a modified standard and is shown with keyways for use with the removable type handle.

Aluminum circuit designation plates are available for all three types.

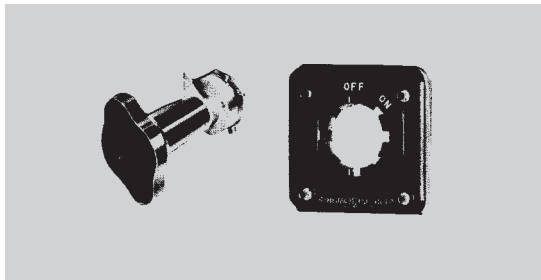

Keyed Escutcheons and Removeable Handles

The removable handle commonly used in synchronizing switches can be made to be removed in any one of the eight positions. There are three keys set in front of the handle, so that they fit the designated keyways in the escutcheon in a desired position. The escutcheon can be keyed so that a handle is interchangeable or non-interchangeable with another switch. If this is desired, the catalog number of the other switch and the position in which the handle is to be removed must be given. The removable handle is not furnished with the switch, but as a separate item.



Handles

Four types of molded black phenolic handles shaped for easy gripping are available with the SBM switch: pistol grip, oval, knurled and lever. Any of the standard handles except the lever, may be adapted for removable handle keying. A fixed handle may be easily removed for replacement by a screw in the front of the handle. A white pointer, furnished with the handles (except the lever) and mounted near the escutcheon, give a clear identification of the position that the handle is in. For match and line up with SB-1 switches, type SB-1 pistol grip, oval, knurled and round handles can be furnished for use with SBM switches.



Cams and Contacts

The silver to silver contacts of the SBM switch are of double-break design, as seen at left, which reduces arcing and subsequent pitting of contacts. Each contact is operated by a double surface cam, one surface for closing, the other surface for opening. This construction provides opening and closing action not dependent on springs.

SBM Features

Slip Cams

The slip cam is basically used on breaker control switches. The slip action enables a contact to remain closed or open after returning to the normal (12 o'clock) position from either the CW or CCW positions.

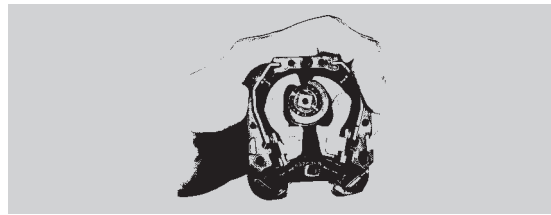

Positioning

Contacts of the SBM switch are positively positioned by a detent wheel mounted on a square shaft and acted upon by a spring-loaded roller arm. If the shaft of the 45° switch is not rotated more than one-half the distance between positions, it will snap back to its prior position. If rotated more than half the distance between positions, it will snap to the next position. The 90° switch has this same positive detent action when in position, but the snapping action is not as prominent. Up to eight positions are available with 45° or 90° between positions.

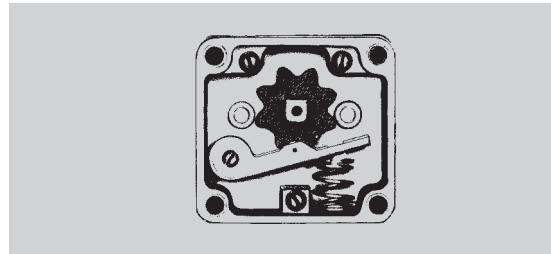

Jumpers

Jumpers are furnished assembled, where required, on all standard listed switches. For special switches or unlisted switches, separate jumpers can be ordered.

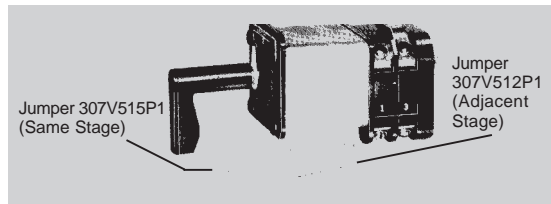

Break-Before-Make Contacts

Contacts on SBM switches are normally non-overlapping (break-before-make). This sequence is illustrated to the right, which shows that contact No. 1 opens before contact and No. 2 closes.

Another normal function is illustrated by contact No. 3, which is shown in two adjacent positions. When switching between these positions, this contact will always remain closed.

Contact Handle End.	Positions		
	3	2	1
			X
		X	
	X	X	

Spring Action

Torsion springs return the switch handle to or towards the 12 o'clock or No. 3 position. The travel of the handle is limited to 90° to either side of position 3. The switches may be furnished with spring return both ways, or only one way, with maintaining action in the opposite direction. You can also have spring return from position No. 1 (9 o'clock) to position No. 2 (10 o'clock) and/or spring return from position No. 5 (3 o'clock) to position No. 4 (2 o'clock) with maintained action in other positions. Torsion springs are housed in the rear half of the positioning chamber. There is no need to modify the chamber to accommodate the springs.

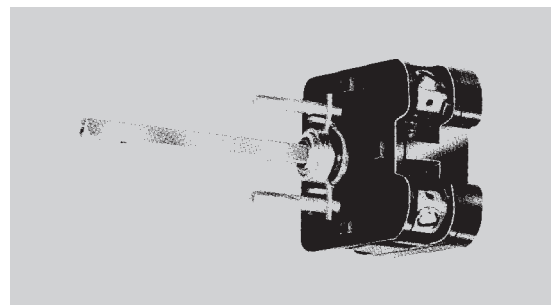

SBM Compact Cam-operated Switch

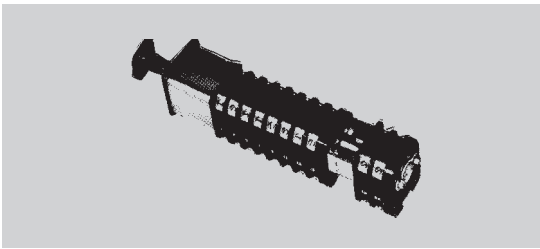

Add-A-Stage

A one-half inch extension is provided on the rear of all switches with one to eight stages. This extension enables a maximum of two additional stages to be easily and economically coupled to the existing switch in the event more contacts are required. Maximum number of stages, including Add-A-Stage unit is 10 (20 contacts).

Contacts Handle End											
	Odd	Even	*	3	2	*	1	*	0H		
1	X	X	X	X	X	X	X	X	X		
2						X	X	X			
3	X	X	X			X	X	X	X		
4				X	X	X					
5	X	X	X	X	X	X	X	X	X		
6	X	X	X								

Overlapping Contacts

Overlapping contacts (make-before-break) contribute to the versatility of the SBM switch.

Typical overlapping contacts are shown on Switch Model No. 10AA009 see Fig. 9 - page 26. The asterisk(*) indicates an intermediate (non-feel) position and shows the contacts overlapping. In the 10AA009 when turning from the OFF position to reading position "1" (Phase 1), contact 2 closes at the intermediate position and before contact 1 which remained closed through the intermediate position, opens.

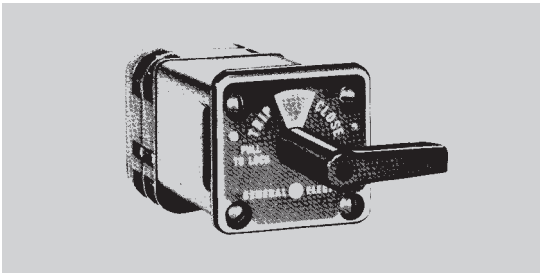

Pull-To-Lock

A pull-to-lock mechanism is designed for spring-return switches. When the handle is turned to the 9 o'clock position, it can be pulled and locked in that position. When the handle is pushed in, the handle spring returns to the normal position. This pull-to-lock feature does not actuate contacts, but merely prevents the spring return of the handle.

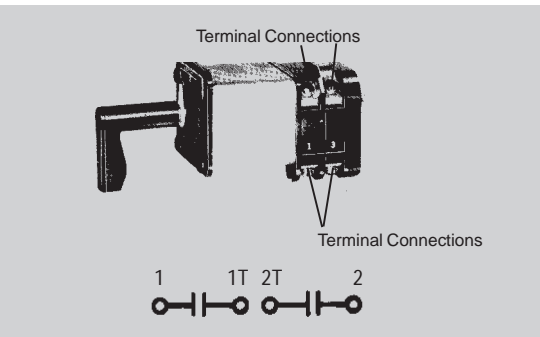

Terminal Connections

Terminal connections are brought to the corners of each stage, allowing screw connections to be made over a large angle. This angular displacement of connection points allows the switches to be mounted on three-inch centers or less. Typical terminal numbering is shown in figure at left.

The SB-1 Switch offers the following features . . .

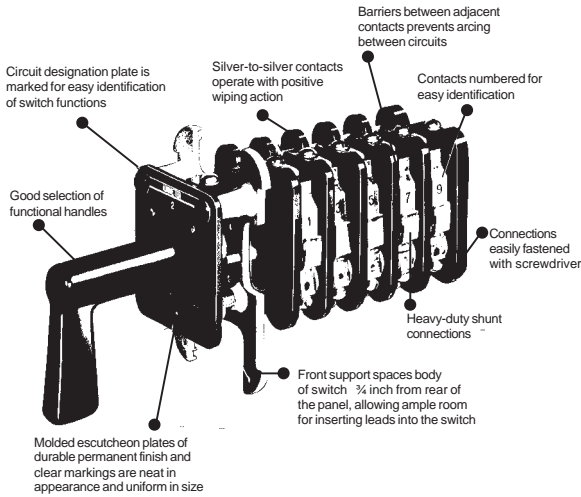

Removable covers (not shown) enclose all live parts

The SB-9 Switch adds these features . . .

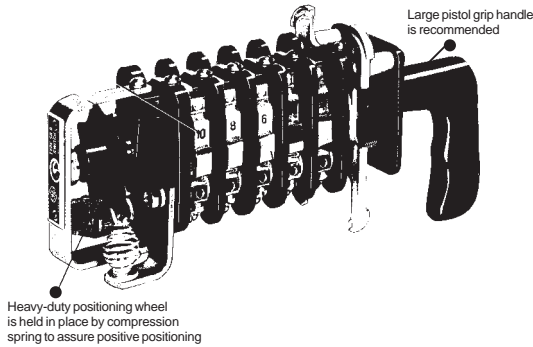

The SB-10 Switch adds these features . . .

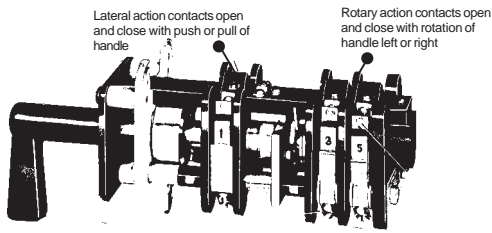

SB-1/SB-9/SB-10 Switches

SB-1 Flexible Control Switch

The SB-1 Switch is a rotary, cam-operated device for the flexible and dependable control of electrically operated circuit breakers, small motors, magnetic switches and similar devices, and for the transfer of meters, instruments and relays.

The SB-1 Switch has molded cams assembled on a square shaft to prevent slipping. Rotation of the shaft moves cams directly against contact arms so that positive high pressure results at the contact. Contact action is not dependent on springs.

SB-9 Highly Repetitive Control Switch

The SB-9 Control Switch is designed for heavy-duty service involving repetitive operations. The SB-9 switch features are similar to the SB-1 except it has a more positive positioning device, better insulation to ground, and more substantial bearings. The contact development diagrams for specific applications follow the same general form as for the SB-1.

SB-10 Lateral Action Switch

is similar to the SB-1 Switch features, except for the addition of lateral action contacts which provide two electrically separate and mechanically independent switches in one device and are located at the handle end of the switch. The lateral contacts operate independently of the rotary contacts. There may be as many as four stages of lateral contacts (two contacts per stage).

SB-1, SB-9 & SB-10 are recognized under the component program of Underwriter's Laboratories, Inc.



GE Power Management

SB-1 / SB-9 / SB-10 Features

SILVER-TO-SILVER CONTACTS

Silver-to-silver contacts operate with a positive wiping action to provide low-resistance current flow. Contacts can be removed independently of other switch parts. Barriers between adjacent contacts prevent arcing between circuits. The switch, complete with cover, can be obtained with up to 16 stages, two electrically separate contacts per stage and for mounting on panels from 1/8" to 2" thick. The panel thickness should be specified when the switch is ordered; if it is not, the switch will be furnished for mounting on panels up to 3/16" thick. The SB-1 switch, which has a standard insulating cover, meets NEMA 1 requirements for panel mounting.

STANDARD PARTS

Flexibility and low initial cost are the results of standardizing a basically simple design. Standard SB-1 switches are available for most applications. For special applications, switches can be built from standard parts. The long-wearing cams, positive wiping action of silver-to-silver contacts, and positive contact opening and closing action all contribute to a switch which is high in quality and will give you many years of dependable service.

LATERAL ACTION

The lateral action capabilities of SB-10 switches are given in the table. The maximum number of stages, including rotary contacts, is 12. Lateral contacts on the same stage must open and close together.

There are only two lateral positions: IN or OUT. Contacts may be closed in either position. A spring can be furnished so that one of the positions is momentary.

Rotary contacts may have a spring to return the switch to neutral rotary position. When a switch is furnished with both lateral and rotary spring return, the lateral spring can be loaded in the neutral rotary position only.

Interlocks may be provided so that the lateral action can be made in one or more rotary positions. Interlocks may also be provided to prevent rotary action in the IN or OUT positions, or to permit rotary action in both the IN or OUT positions.

The same types of fixed handles and escutcheons used in SB-1 switches

may also be used with the SB-10 switches. Drilling dimensions are the same as the SB-1. (See **Table 2** below)

Table 2: Lateral Action of SB-10 Switch

Table 2: Lateral Action of SB-10 Switch	
One Lateral Stage	
Pull to open contacts 1-2	Maintaining or spring return in or out
Pull to close contacts 1-2	Maintaining or spring return in or out
Two Lateral Stages	
Pull to open contacts 1-4	Maintaining or spring return in or out
Pull to close contacts 1-4	Maintaining or spring return in or out
Pull to open contacts 1-2 and close 3-4	Maintaining or spring return in or out
Three Lateral Stages	
Pull to open contacts 1-6	Maintaining or spring return in
Pull to close contacts 1-6	Maintaining or spring return out
Pull to open contacts 1-4 and close 5-6	Maintaining or spring return in
Pull to open contacts 1-2 and close 3-6	Maintaining or spring return out
Four Lateral Stages	
Pull to open contacts 1-8	Maintaining or spring return in
Pull to close contacts 1-8	Maintaining or spring return out
Pull to open contacts 1-6 and close 7-8	Maintaining or spring return in
Pull to open contacts 1-2 and close 3-8	Maintaining or spring return out
Pull to open contacts 1-4 and close 5-8	Maintaining or spring return in or out
<i>Pull to open denotes the same contact action as push to close.</i>	
<i>Pull to close denotes the same contact action as push to open.</i>	

RATINGS

Type SB-1, SB-9 and SB-10 switches are rated 600 volts, 20 amps continuous, or 250 amps for three seconds. The interrupting rating depends upon the voltage and character of the circuit, and

the number of contacts connected in series. Contacts can be paralleled when the current exceeds 20 amps. (See **Table 3** below)

Table 3: Circuit Volts	Non-Inductive Circuit			*Inductive Circuit		
	Number of Contacts					
	1	2 in Series	4 in Series	1	2 in Series	4 in Series
Interrupting Rating in Amperes						
24 dc	6	30	4	20	30
48 dc	5	25	40	3	15	25
125 dc	2.5	11	25	2	6.25	9.5
250 dc	.75	2	8	.7	1.75	6.5
600 dc	.25	.45	1.35	.15	.35	1.25
115 ac	40	75	24	50
220 ac	25	50	12	25	40
440 ac	12	25	5	12	20
550 ac	6	12	4	10	15

* Values of inductance equal to that of the average trip circuit. For circuits having high values of inductance, refer application to your GE representative for recommendations.

SB-1, SB-9 & SB-10 are recognized under the component program of Underwriter's Laboratories, Inc.

SB-1, SB-9 & SB-10 Features

HANDLES

Seven different types of fixed handles are shown (A to G). The handles are designed for durability, comfortable grip, and pleasing appearance. An arrow is embedded in the oval and pistol-grip handles for visual aid in positioning. A white pointer is furnished with the knurled and round handles.

In addition to the seven above, a removable type oval handle (H) is available for the SB-1 or SB-9 switches, to prevent inadvertent operation of equipment by unauthorized persons. The removable handle is keyed to fit the escutcheon in a specific position. All but the radial and the lever type handles can be furnished with keyed shanks as removable type handles. The handle can be removed in any one or two positions, and such positions should be specified when the switch is ordered.

ESCUTCHEONS

The escutcheon is made of molded black phenolic material with white lettering for clear reading of position labels.

Types of escutcheons:

1. The standard type C, E, or F (See Fig. 8A), is used when all positions are at the horizontal or above.
2. The round type, A or D is used when there are positions below the horizontal.
3. A target-type escutcheon B & G are normally used on breaker control switches, has a red and green target to indicate the last position to which the switch was turned. Pull-to-lock target escutcheons (A to C) are shown to the right. (Note that maximum throw is 75° counter-clockwise and 45° clockwise).
4. Both the standard and the round type escutcheons can be furnished with keyways to interlock with the removable type handles, so that the handle is removable only in a specific position.

A separate circuit designation plate, when furnished, is mounted at the top of the escutcheon and is easily removable.

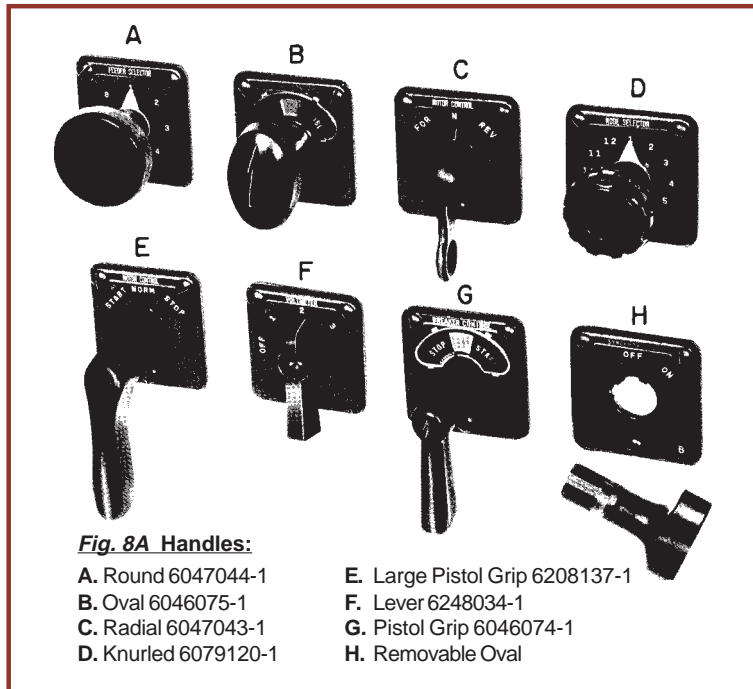

POSITIONS

The maximum number of positions is 12. Position locations and throws are available as shown.

PULL-TO-LOCK TARGET ESCUTCHEONS

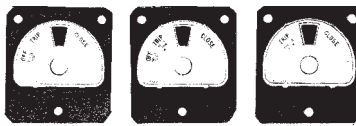

2 POSITIONS
90° APART



2 TO 4 POSITIONS
90° APART

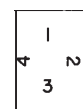

2 TO 5 POSITIONS
37½° APART

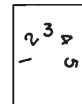

2 TO 6 POSITIONS
60° APART

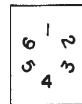

2 TO 8 POSITIONS
45° APART

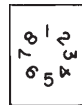

2 TO 10 POSITIONS
36° APART

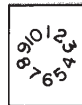

2 TO 12 POSITIONS
30° APART

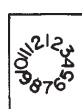

SB-1/SB-9/SB-10 Features

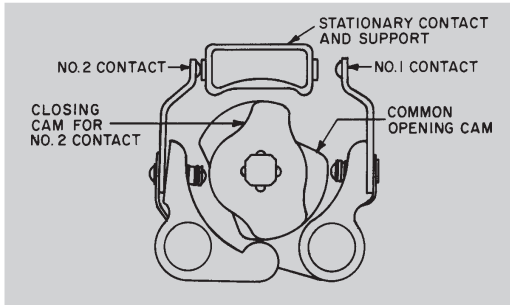

Figure 9A: Moving Cam Operated Contacts

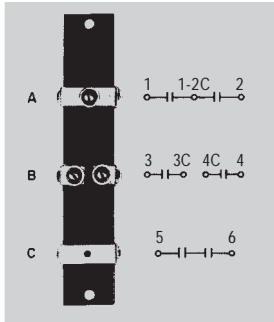

Figure 9B: Stationary Contacts

(showing typical terminal numbering)

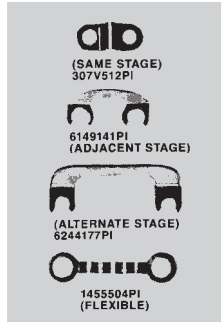

Figure 9C: Jumpers

CONTACTS AND JUMPERS

Rotary contacts on SB-1, 9, and 10 switches are normally break-before-make. Overlapping contacts (make-before-break) are available and are used basically in ammeter switching applications. Slip contact operation is available for breaker control application. Moving contacts are cam operated for positive opening and closing (**Fig. 9A**). Stationary contacts are assembled on a common support, mounted at the top of the switch for easy replacement. Three types of stationary contacts are available (**Fig. 9B**).

A. Electrically common with center binding post, which affords single-break, single-pole, double-throw operation for two electrically common circuits.

B. Electrically separate. Each stage affords single-break, single-pole service for two electrically separate circuits.

C. Electrically common without a center binding post, affording two contacts for double-break action.

Greater switch flexibility can be achieved by use of jumpers (**Fig. 9C**). Four different types are illustrated. When jumpers are ordered with the switch, they are supplied unassembled without additional cost. They may also be purchased separately and assembled on existing switches.

SPRING RETURN ACTION

Spring return can be adapted to any SB-1, 9, and 10 switch providing these limitations are adhered to:

1. The handle must return to or toward the 12 o'clock position, but not pass it.
2. The maximum throw is 90° to either side of the 12 o'clock position.
3. You cannot have a maintained position past a spring return position.

Example: if spring return from pos. 2 to pos. 3 is desired pos. 1 cannot be a maintained position. However, the functional equivalent can be obtained by specifying a pull-to-lock action in place of the maintained position. Spring return from both directions to NORMAL or spring return with maintained action can be provided on the same switch.

Example (Fig. 9D):

A. Spring return from position 1 and 2 to 3 maintaining in positions 3, 4 and 5 or spring return from 5 to 4 to 3 maintaining in positions 1, 2 and 3.

B. A five position switch can be furnished with partial spring return from positions 1 to 2 and/or 5 to 4 with maintaining action in the remaining positions (SB-9 only).

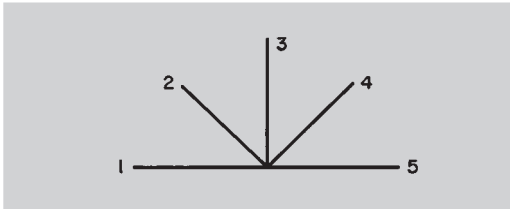

Figure 9D: Spring Return Positions



PROTECTIVE COVER

A separate and removeable protective cover is standard with the SB-1, SB-9, and SB-10 switches. The cover's insulative characteristics provides coverage of the exposed connections and contacts from any live parts making it an ideal spec for panel mounting. The four sided cover and metal face plate, slides over the entire staged area and is attached by a knurled type nut that can be attached by hand. An optional large cover (not shown) is available and has a deeper bottom section providing additional space for large capacity cable assemblies. The SB series protective cover meets all NEMA 1 requirements.

SB-1/SB-9/SB-10 Optional Features

TANDEM SWITCHES

The SB-1 and SB-9 switches are limited in length to 16 stages. The SB-10 switch is limited to 12 stages. When more stages are required two or more switches can be assembled in tandem. The tandem arrangement is compact, and allows a large number of circuits to be controlled with a single handle from a small space on the switchboard. The tandem switch can be mounted vertically or horizontally. (See page 22 for dimensions)

PALLADIUM CONTACTS

Available for temperature meterswitches. Palladium contacts have a constant resistance factor which is necessary because calibrated leads are normally used in temperature meter circuits. Silver contacts would result in a variable resistance factor and cause fluctuations in meter readings.

LOCKS

Two different types of locks are available. Each allows the switch to be locked in one or more positions. One lock is built into the operating handle. The other lock is separately mounted on the panel above the switch, and when necessary, can be coordinated with a Kirk Key-Interlock Scheme. (See page 23 for dimensions)

When it is necessary to lock switches in more than one position, a 45° space must be provided between adjacent locking positions. Therefore, eight is the maximum number of lock positions that can be furnished.

PULL-TO-LOCK

A pull-to-lock may be added to lock the switch against spring return action. Locking is accomplished by pulling the handle out in the pull-to-lock position to engage a latch which arrests the spring return. The switch will remain in the locked position until the handle is pushed in. *Note.* This pull-to-lock feature does not actuate contacts when pulled.

The following are standard pull-to-lock combinations available with a standard target type escutcheon.

- A. Spring return from all positions to NORMAL except when locked, pull handle to lock at 75° CCW.
- B. Spring return from 45° CW and CCW to NORMAL, pull to initiate locking at 45° CCW then turn to 75° CCW and pull-to-lock.
- C. Spring return from 45° CW and CCW except when pulled-to-lock at 45° CCW. Special pull-to-lock switches can be furnished; however, spring return action from the pull-to-lock position is required.

PULL-TO-TURN

A pull-to-turn feature can be incorporated in a SB-1 or SB-9 switch to prevent accidental operation. The handle is locked against turning when it is in the "in" position and must be pulled out to unlock and turn to the selected positions; it is equipped with a lateral spring that pulls the handle to the "in" position. The handle can be locked against turning in one or more positions, or can be free to rotate between certain positions while in the "in" position. Rotary spring action is not recommended with "pull-to-turn" because the lateral spring may not always overcome the rotary spring and automatic return to neutral may not always occur.

PUSH-TO-TURN

The "push-to-turn" feature is almost the exact opposite of the above shown "pull-to-turn" feature, and the same restriction as to the use of rotary spring return applies.

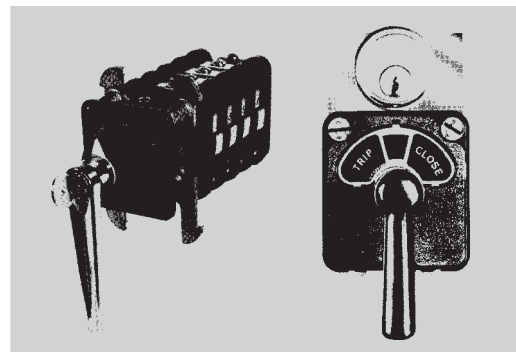
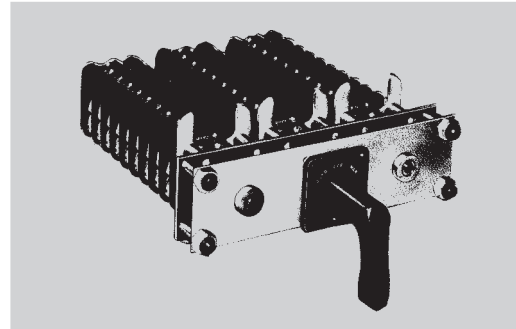

Description of Cam Action & Limitations

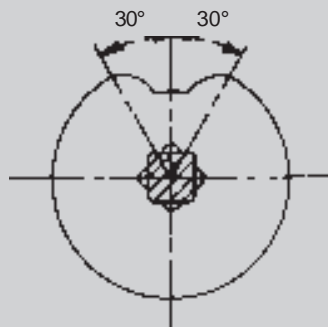

Figure 11A: Operating cam for SB-1, 9 & 10 Switches

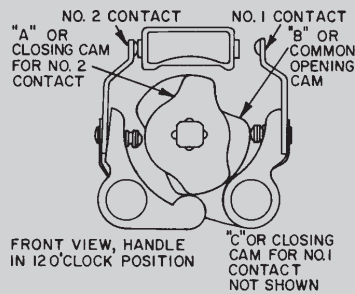

Figure 11B: Composite view of contacts and cams

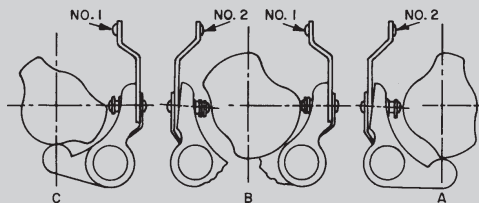

Figure 11C: Individual arrangements of cams in Fig. 2

	CONTACTS HANDLE END		POSITION (BACK VIEW)		
			3	2	1
	1		X		
	2		X	X	

Figure 11D: Contact arrangement, back view

The operating cam of SB-1, 9, and 10 switches is based on a 30° cut to each side of the center (**Fig. 11A**). A standard-profile cam will fully open or close a contact in 30°, making or breaking 15° from the fully open or fully closed position.

Fig. 11B is a composite view of contacts and cams assembled on a stage of a switch. This figure shows that odd-numbered contacts are on the right side of the switch (viewed from the front), and are closed by the “C” cam. Even-numbered contacts are on the left side, and are closed by action of the “A” cam. Both contacts are opened by the “6” cam.

Fig. 11D is the contact diagram for **Fig. 11B**, with **Fig. 11C** showing the individual arrangement of cams.

One cam limitation must be considered when the switch rotates 180° or more. Referring to **Fig. 11C**, when cam B is rotated 180°, the same relationship occurs between the periphery of Cam B and the contact mechanism of Contact No. 1 as occurred between the periphery and contact mechanism of Contact No. 2 before rotation; therefore, whatever happens to one contact at any point in the switch rotation must happen to its companion contact in the same stage when the switch is rotated 180°. **Fig. 12A** shows the diagram of an unworkable and a correct arrangement.

When contacts on the same stage cannot be arranged to avoid this 180° cam limitation, one contact per stage is used (See **Fig. 12B**). On five-position switches, 37½° can be used instead of 45°, to avoid this limitation.

SLIP CAMS

Slip cams increase the flexibility of the switch. They allow a contact to be *closed* in the NORMAL position after returning from either the CW or CCW position, and also to be *open* in the NORMAL position after returning from the opposite direction. This action is accomplished by allowing the cam to slip 45° as shown in **Fig. 12C**. Once the shaft actuates the cam, the shaft will then slip 45° in the opposite direction without actuating the cam.

This type of action is commonly used for circuit-breaker control applications. **Fig. 12D** shows a breaker control switch, Model 16SB1B2, which has slip action on Contacts 7 and 8. With this slip action, there are some limitations. Three of these limitations and how to avoid them are shown. Limitation No. 1 does not apply to the SBM switch because of the independent cams for each contact.

Cam Action and Limitations

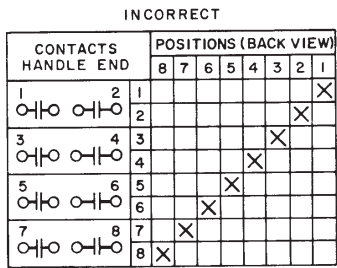
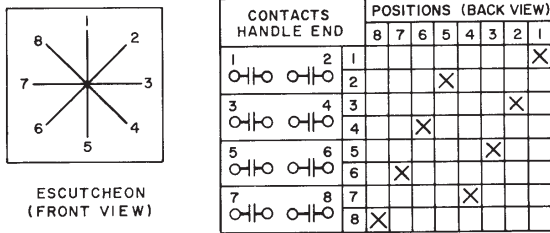

Figure 12A:
Diagram of unworkable and correct arrangement

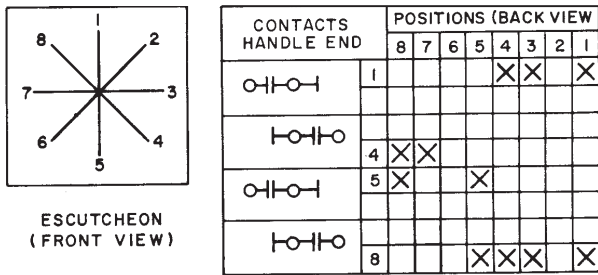

Figure 12B:
Contact arrangements to meet cam limitations

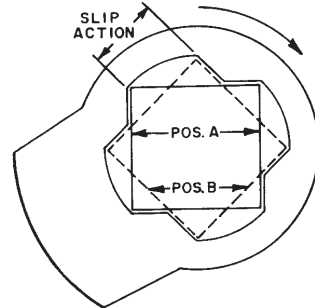
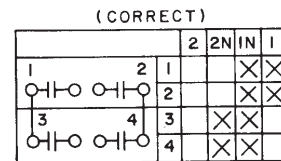
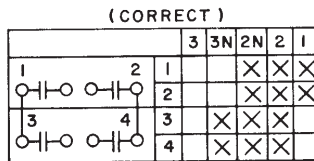
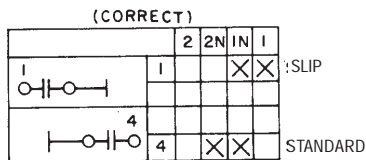
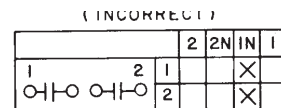
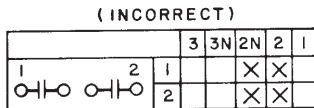
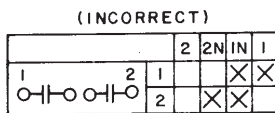

Figure 12C:
Diagram showing 45° slip action of cam

CONTACTS HANDLE END		POSITIONS			
		Close	Norm after close	Norm after trip	Trip
1	2	X			
3	4	X			X
5	6		X	X	
7	8	X	X		

Figure 12D:
Breaker control switch model 16SB1B2



Limitation No. 1 (SB-1/SB-9/SB-10)
A slip contact and standard contact cannot be on the same stage, as shown in the top diagram.

A stage must be added and contacts split up, as shown in the bottom, one contact per stage. (Does not apply to SBM).

Limitation No. 2 (SBM/SB-1/SB-9/SB-10)
On a 4-position pull-to-lock switch the slip contact cannot be closed in the 2N and 2 positions (as shown in the top diagram) without closing in position 1. To accomplish this, a stage is added and the contacts are connected in series as shown in the bottom diagram.

Limitation No. 3 (SBM/SB-1/SB-9/SB-10)
A contact cannot be closed in the normal after position without also closing in the position itself, as shown in the top diagram. To accomplish this, a stage must be added and the contacts set up as shown in the bottom diagram, with the contacts placed in series by jumpers. Jumpers required are shipped loose with the switch.

Overlapping Contacts

CONTACTS		POSITIONS			
HANDLE END		3	2	1	
1				X	
2			X		
3		X	X		

Fig. 13A: Typical Non-overlapping (break-before-make) Sequence

AMMETER	OFF	3	1	2	CONTACTS		INTER. POSITION										
					ODD	EVEN	8	7	6	5	4	3	2	1			
					1		X	X	X	X	X	X	X	X	X	X	X
					2				X	X	X						
					3		X	X	X	X	X	X	X	X	X	X	X
					4		X	X	X								
					5		X	X	X	X	X	X	X	X	X	X	X
					6		X										X

Fig. 13B: Overlapping Contacts for SBM Ammeter-type Switch Connected at End of Secondary

AMMETER	OFF	3	1	2	CONTACTS		INTER. POSITION										
					ODD	EVEN	8	7	6	5	4	3	2	1			
					1		xxxxxx	xxxxxx	xxxxxx	xxxxxx	xxxxxx	xxxxxx	xxxxxx	xxxxxx	xxxxxx	xxxxxx	xxxxxx
					2				xxx								
					3				xxx								
					4				xxx								
					5				xxx								
					6		xx	xxxxxxxx	xxxxxxxx	xxxxxxxx	xxxxxxxx	xxxxxxxx	xxxxxxxx	xxxxxxxx	xxxxxxxx	xxxxxxxx	xxxxxxxx
					7		xxxxxx	xxxxxx	xxxxxx	xxxxxx	xxxxxx	xxxxxx	xxxxxx	xxxxxx	xxxxxx	xxxxxx	xxxxxx
					8												xxx
					9												xxx

Fig. 13C: Overlapping Contacts for SBM Ammeter-type Switch, with Three Independent Circuits

AMMETER	1	2	3	CONTACTS		POSITIONS						
				HANDLE END		3	Inter	2	Inter	1		
				1			X	X				
				2				X	X	X	X	
				3						X	X	
				4			X	X	X	X		

Fig. 13D: Overlapping Contacts for SB-1 Ammeter-type Switch Connected at End of Secondary (two current transformers)

GENERAL

Contacts on Type SB switches are normally non-overlapping (break-before-make). This sequence is illustrated in Fig. 13A which shows that Contact No. 1 opens before Contact No. 2 closes, when turning from Position 1 to Position 2.

Another normal function is illustrated by Contact No. 3, which is shown closed in two adjacent positions (Positions 2 and 3). When switching between these positions, the contact will always remain closed. There are some circuits where this action is not desired, such as switching current transformers to an ammeter. Here, the contacts must overlap (make-before-break) to prevent damaging the meter.

SBM SWITCH

To get this overlapping action on the contacts, 90° between positions is required. Fig. 13B illustrates an ammeter switch (similar to Model No. IOAA009, see Fig. 9 - page 26) with overlapping contacts. The overlapping action takes place in the intermediate positions (Positions 2, 4, 6, and 8). The intermediate position is identified by an "X" in the block above this position in the operating requirement table. Contacts 1 and 2 are shown overlapping in the intermediate Positions 4 and 6. Contact 2 is shown making in intermediate Position 4 before Contact 1 breaks, when going from Position 3 (OFF) to Position 5 (PHASE I), and Contact 1 will make before Contact 2 breaks, when going from Position 5 to Position 7.

Fig. 13C illustrates an ammeter switch for three independent current transformers (similar to Model No. IOAA013, see Fig. 13 - page 27). This switch also has overlapping contacts and intermediates at Positions 2, 4, 6, and 8; however, the overlapping action takes place between the intermediate position and the actual position. The "X" on the line between the positions of the contacts identifies this action. When turning from Position 5 (PHASE I) to Position 7 (PHASE II), Contact 1 makes before Contacts 2 and 3 break. Also, Contact 2 and 3 break before Contacts 4 and 5 make, and Contacts 4 and 5 make before Contact 6 breaks. All this action takes place within the 90° between positions, by use of a special cam.

SB-1, -9, AND -10 SWITCHES

Basically, the overlapping action is the same as with the SBM switch, but it is not limited to positions which are 90° apart. To get a make-before-break action, as shown in Fig. 13D, a minimum of 37½° between positions is required. To get a make-before-break as shown in Fig. 14A, a minimum of 60° is required. The flexibility of the SB-1, -9, and -10 switch allows the combination of 37½° and 60° in the same switch to give you an ammeter switch which reads as many as six, independent, current transformers with either 1 or 2 OFF's (See Fig. 14B).

A special contact sequence which requires a contact to close in adjacent positions, but to open momentarily between them, is shown by Contact 1 in Fig. 14C. A minimum of 60° between positions is required. When less than 60° is required, use two contacts in parallel, as shown in Fig. 14D.

Overlapping Contacts

Fig. 14A: Overlapping contacts for SB-1 ammeter-type switch, with three independent circuits.

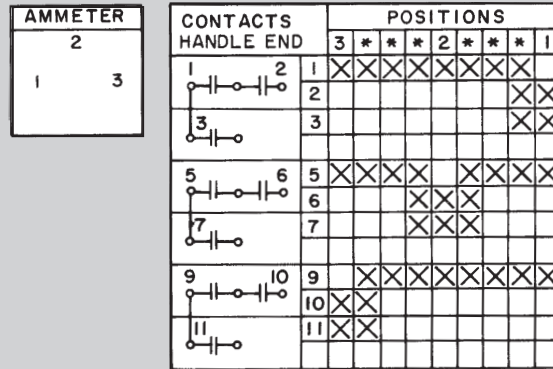

Fig. 14B: Overlapping contacts for SB-1 switch, with six independent circuits.

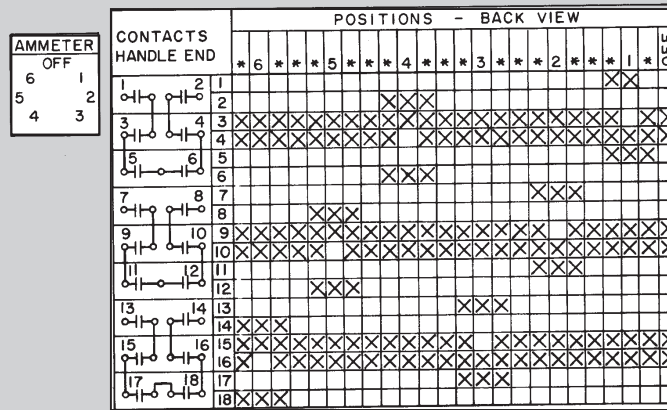

Fig. 14C: Special contact sequence which requires one contact to be closed in every handle position, but to open momentarily when switching.

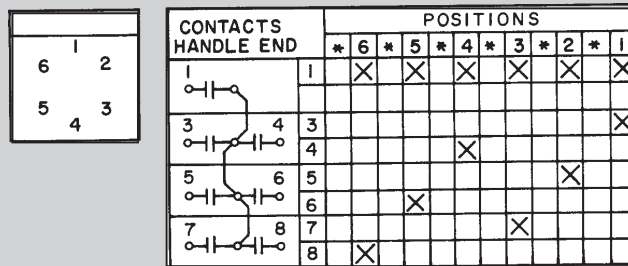
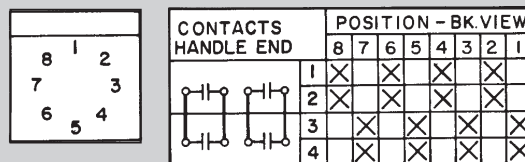

Fig. 14D: Special contact sequence which requires one contact to be closed in every handle position, but to open momentarily when switching; however, when less than 60° between positions is required, two contacts are connected in parallel.



Removable Handles

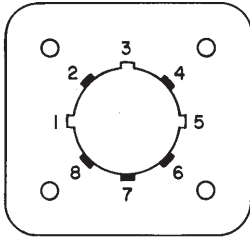

Fig. 15A:
SBM Switch Keyed Escutcheon
with Eight Available Keyway
Locations.
Keyways 1, 3 and 5 are Shown

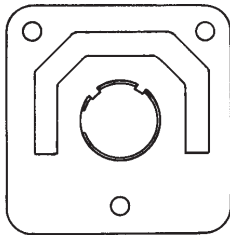

Fig. 15B:
SB-1 & SB-9 Escutcheon for
Use with Removable Handle

DESCRIPTION

To prevent operation of equipment by unauthorized persons, switches with removable handles are available. The handle is keyed to a specific escutcheon, to be inserted and removed in a designated position. Handles can also be mutually keyed to other escutcheons, so that they are either interchangeable or non-interchangeable with other switches.

This feature is available for SBM, SB-1, and SB-9 switches, but ordering procedures differ.

SBM SWITCHES

The keyed escutcheon on the SBM switch (**Fig. 15A**) has eight possible keyway locations. Three are normally used and are assigned by the factory. The choice is influenced by several factors:

- a. If the handle is to be interchangeable with that of another switch, the position in which each handle is to be removable must be considered.
- b. If the handle is to be non-interchangeable, the keyways assigned to other removable handles in the same panel must be considered.
- c. If no special instruction is given by the customer when he orders, the factory will assign keyways at random; if more than one SBM switch has a removable handle, they will be keyed to be non-interchangeable.

A removable handle is furnished as a separate item, not with the switch it operates, because in some cases the single handle operates many switches. The handle is keyed so that it will fit through the keyways on the escutcheon in a specific position.

When ordering a removable handle, specify the type, the position in which it is to be removable, and the switch or switches it will be used with. The factory will assign the handle. To identify SBM removable handles, see **Table 4** below.

Table 4: Nomenclature Guide for SBM removable handles

1st Number	2nd Number	1st Letter	2nd Letter	3rd No.	4th No.	5th No.
Handle Type	Removable in Position	Common Code	Action of Rotation	Escutcheon Keyways		
1 = Knurled	1	W	W = CW & CCW	1	1	1
2 = Oval	thru		L = CCW (special)	thru	thru	thru
3 = Pistol	8		R = CW (special)	8	8	8

Example 1: 21WW135

This oval handle has keys at positions which, when it is in position 1, or 9 o'clock, will line up with escutcheon keyways 1, 3 and 5. It is therefore removable in position 1.

Removable Handles

SB-1 & SB-9 SWITCH

The keyed escutcheon for the SB-1 & SB-9 switch is normally furnished with two keys and three keyways (See Fig. 15B). The circumferential location of the keys and keyways will vary, depending on the location, etc., in which the handle is to be removable. The location of the keyways is assigned by the factory.

Table 5 gives a list of standard keyed escutcheons and the proper removable handle for removing the handle in both the vertical (12 o'clock) position and 90° CCW (9 o'clock) position. Escutcheons 6016164P2 thru P14 are used on switches if the throw does not exceed 90° on either side of the vertical (12 o'clock) position, and P23, 24 and 25 are used when the throw does exceed this limit.

Oval handles 16SB1CC1 thru 32 are listed with direction and degree of throw from the positions in which they are removable. The code letters A thru Z in the left hand column identify the escutcheons used on the basic unlisted switches.

Example: 16SB1AB300SAM3Y, the 2nd form letter A identifies a keyed escutcheon 6016164P 3.

When a special keyed escutcheon is required, different from any of those listed, the code letter "X" is used followed by the part number.

Example: 16SB1AB300SX34M2Y.

All keyed escutcheons will now have the part number stamped at the bottom left hand corner instead of the code letters previously stamped at the bottom righthand corner. If the code letter or other identification is desired, it will be stamped at the bottom righthand corner by requisition only (three characters maximum). The 16SB1CC oval type removable handle will now have the form number only (suffix number following 16SB1CC in "handle" column in Table 5) stamped on the lower face of the handle. Those removable handles which have metal shanks (6119745G) will have the group number stamped on the shank. When a switch with a keyed escutcheon for a removable handle is ordered, be sure to specify the position in which the handle is to be removable. If an existing handle will be used, give the number of the existing handle.

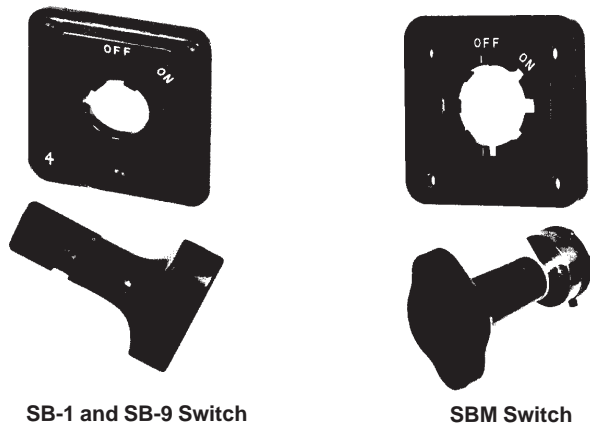

SB-1 and SB-9 Switch

SBM Switch

Fig. 16A: Typical Removable Handles and Escutcheons

Table 5: Listing for Escutcheons and Handles

Code	Model Number		Throw
	Escutcheon*	Handle	
Handle Removable in Vertical Position			
A	6016164P3	16SB1CC1	135° CW
A	3	CC18	360°
B	4	CC2	135° CW
B	4	CC19	360°
C	5	CC3	135° CW
C	5	CC15	360°
D	6	CC4	135° CW
D	6	CC11	45° CW & CCW
D	6	CC22	45° CCW
D	6	CC27	360°
E	7	CC5	45° CW
E	7	CC12	75° CW
E	7	CC13	45° CW & CCW
E	7	CC20	360°
E	7	CC25	75° CCW
F	8	CC6	45° CW
F	8	CC14	45° CW & CCW
F	8	CC24	360°
G	9	CC7	45° CW *1" Eng.
G	9	CC8	45° CCW *R" Eng.
G	9	CC17	45° CCW
G	9	CC26	135° CCW
G	9	CC29	45° CW
G	9	CC21	360°
H	10	CC23	360°
H	10	CC9	45° CW *1" Eng.
H	10	CC10	45° CCW *R" Eng.
H	10	CC31	45° CW
H	10	CC32	45° CCW
J	23	CC18	360°
Y	24	CC19	360°
Z	25	CC21	360°
Handle Removable 90° CCW			
K	6016164P11	16SB1CC1	135° CW
K	11	CC18	360°
L	12	CC2	135° CW
L	12	CC15	360°
M	13	CC3	135° CW
M	13	CC15	360°
N	14	CC11	45° CW & CCW
N	14	CC27	360°
N	14	CC4	135° CW
N	14	CC22	45° CCW
X	Special		

*The P number (3, 4, etc.) is used as the part number in text.

Temperature-Meter Switches

DESCRIPTION

Temperature-meter switches are furnished with palladium contacts, which have a constant resistance factor. This is necessary because calibrated leads are normally used in a temperature-meter circuit, and silver contacts would result in a variable resistance factor and cause fluctuation in meter readings.

Figure 17A shows a temperature-meter switch, Model 16SB1CE52, reading four RTD's, on a two-wire circuit with a TEST and an OFF position. On a two-wire circuit, you can transfer up to seven coils with an OFF position, or six coils with a TEST and an OFF position.

Figure 17B shows a Model 16SB1CE55 reading three RTD's, on a three-wire

circuit with a TEST and an OFF position. On a three-wire circuit, you can transfer up to six coils with an OFF position, or five coils with a TEST and an OFF position. When it is required to transfer more RTD's than the maximum for a given switch, two switches with a removable handle may be used.

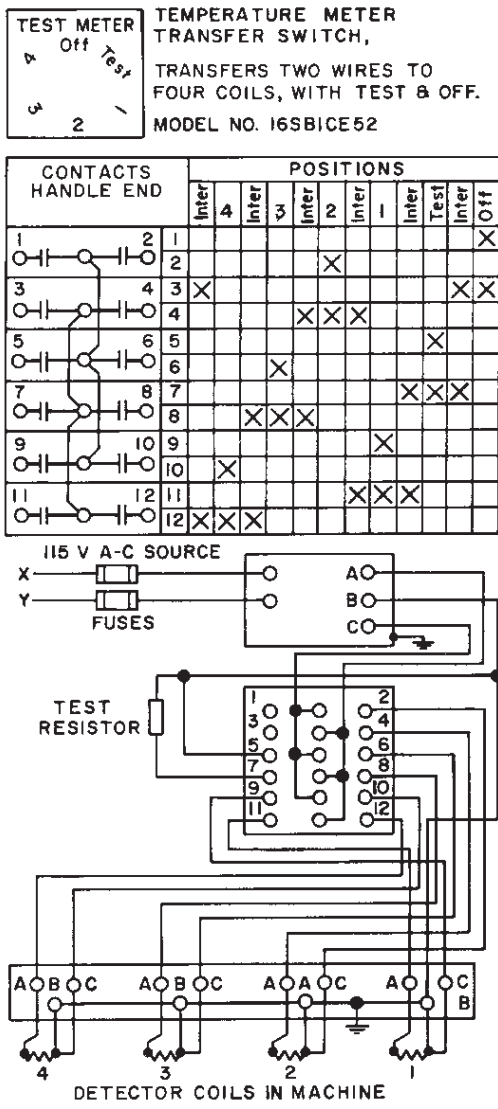

Fig. 17A:
Temperature meter switch,
Model 16SB1CE52

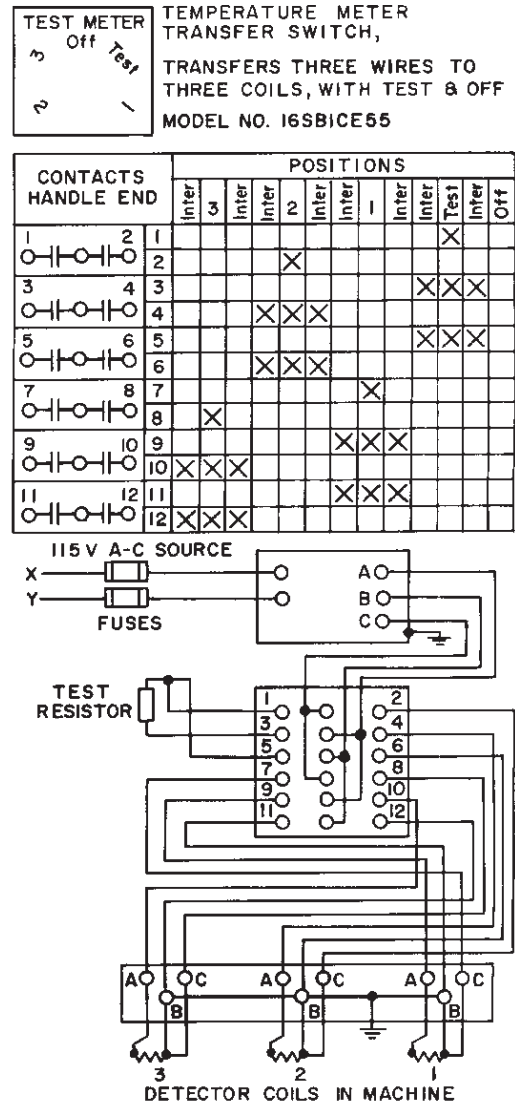
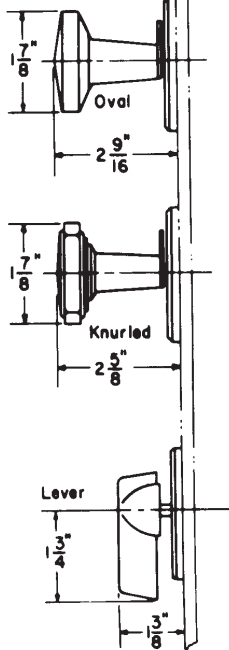
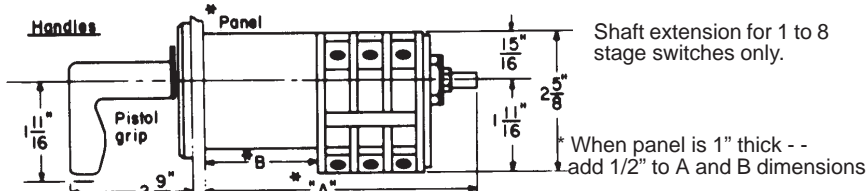

Fig. 17B:
Temperature meter switch,
Model 16SB1CE55

Outline Dimensions

SBM CONTROL AND TRANSFER SWITCHES

(For estimating only)



No. of Stages	Standard Switch		Pull-to-Lock Switch		Removable Handle Switch	
	"A"	B	"A"	B	"A"	B
1	3/8	2 1/8	4 7/16	2 7/8	4 3/4	3 1/16
2	4 1/2	2 1/8	5 7/16	2 7/8	5 3/8	3 1/16
3	5 1/8	2 1/8	5 9/16	2 7/8	6	3 1/16
4	5 3/4	2 1/8	6 7/16	2 7/8	6 5/8	3 1/16
5	6 3/4	2 1/8	7 1/16	2 7/8	7 7/8	3 1/16
6	7 7/8	2 1/8	7 1/16	2 7/8	7 7/8	3 1/16
7	7	2 1/8	8	2 7/8	8	3 1/16
8	8 5/8	2 1/8	8 5/16	2 7/8	9 1/2	3 1/16
9	8 7/8	2 1/8	8 9/16	2 7/8	9 5/8	3 1/16
10	9 1/2	2 1/8	9 7/16	2 7/8	9 7/8	3 1/16
	1 1/8	1 1/8	1 13/16	7/8	3/4	1/16

1/2" hole-standard and pull-to-lock 1-3/8" hole-removable handle

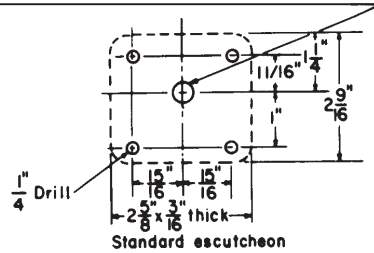

SHIPPING WEIGHTS

Approx weights are listed below. All weights listed apply to SB switches consisting of one stage. Add 6 ounces for each additional stage.

SBM (1 Stage) @ 1 1/2 lbs

(This data is subject to change without notice)

Outline Dimensions

SB-1

CONTROL AND TRANSFER SWITCHES

(For estimating only)

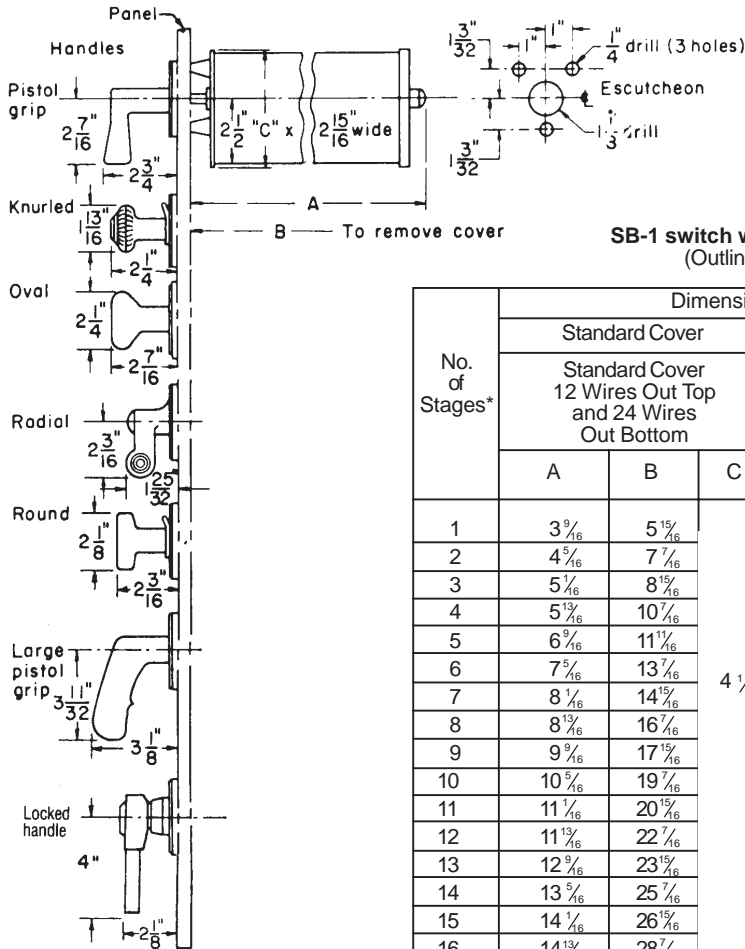

No. of Stages*	Dimension in Inches					
	Standard Cover			Large Cover		
	Standard Cover 12 Wires Out Top and 24 Wires Out Bottom			Large Cover 24 Wires Out Top and Bottom		
	A	B	C	A	B	C
1	3 ⁹ / ₁₆	5 ¹⁵ / ₁₆	4 ¹ / ₂	3 ¹³ / ₁₆	6 ³ / ₁₆	4 ¹⁵ / ₁₆
2	4 ⁵ / ₁₆	7 ⁷ / ₁₆		4 ⁹ / ₁₆	7 ¹¹ / ₁₆	
3	5 ⁷ / ₁₆	8 ¹⁵ / ₁₆		5 ⁵ / ₁₆	9 ³ / ₁₆	
4	5 ¹³ / ₁₆	10 ⁷ / ₁₆		6 ¹ / ₁₆	10 ¹¹ / ₁₆	
5	6 ⁹ / ₁₆	11 ¹¹ / ₁₆		6 ¹³ / ₁₆	12 ³ / ₁₆	
6	7 ⁵ / ₁₆	13 ⁷ / ₁₆		7 ⁹ / ₁₆	13 ¹¹ / ₁₆	
7	8 ¹ / ₁₆	14 ¹⁵ / ₁₆		8 ⁵ / ₁₆	15 ³ / ₁₆	
8	8 ¹³ / ₁₆	16 ⁷ / ₁₆		9 ¹ / ₁₆	16 ¹¹ / ₁₆	
9	9 ⁹ / ₁₆	17 ¹⁵ / ₁₆		9 ¹³ / ₁₆	18 ³ / ₁₆	
10	10 ⁵ / ₁₆	19 ⁷ / ₁₆		10 ⁹ / ₁₆	19 ¹ / ₁₆	
11	11 ¹ / ₁₆	20 ¹⁵ / ₁₆		11 ⁵ / ₁₆	21 ³ / ₁₆	
12	11 ¹³ / ₁₆	22 ⁷ / ₁₆		12 ¹ / ₁₆	22 ¹¹ / ₁₆	
13	12 ⁹ / ₁₆	23 ¹⁵ / ₁₆		12 ¹³ / ₁₆	24 ³ / ₁₆	
14	13 ⁵ / ₁₆	25 ⁷ / ₁₆		13 ⁹ / ₁₆	25 ¹ / ₁₆	
15	14 ¹ / ₁₆	26 ¹⁵ / ₁₆		14 ⁵ / ₁₆	27 ³ / ₁₆	
16	14 ¹³ / ₁₆	28 ⁷ / ₁₆		15 ¹ / ₁₆	28 ¹¹ / ₁₆	

* For spring-return switches when more than three and less than seven contacts close in the normal handle position, add $\frac{3}{4}$ " to "A", and $1\frac{1}{2}$ " to "B". When seven or more contacts close in the normal handle position, add $1\frac{1}{2}$ " to "A" and 3" to "B".

Note: Removable handles are similar to fixed handles and available in all styles except radial and locked. They do not alter switch dimensions or drilling.

SHIPPING WEIGHTS

Approx weights are listed below. All weights listed apply to SB-1 switches consisting of one stage. Add 6 ounces for each additional stage.

SB-1 (1 Stage) @ 2 lbs

(This data is subject to change without notice)

Outline Dimensions

SB-9

CONTROL AND TRANSFER SWITCHES

(For estimating only)

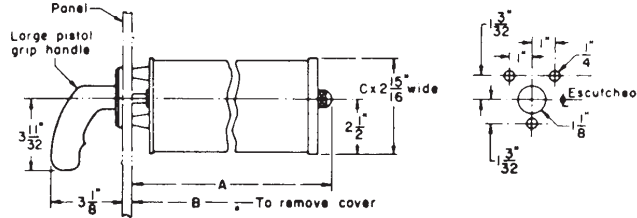

Panel-mounted SB-9 switch
(Outline 116A139)

No. of Stages*	Dimension in Inches					
	Standard Cover 12 Wires Out Top and 24 Wires Out Bottom			Large Cover 24 Wires Out Top and Bottom		
	A	B	C	A	B	C
1	4 ⁷ / ₈	8 ³ / ₈	4 ¹ / ₂	5 ¹ / ₈	8 ⁵ / ₈	4 ¹⁵ / ₁₆
2	5 ⁵ / ₈	9 ⁷ / ₈		5 ⁷ / ₈	10 ¹ / ₈	
3	6 ³ / ₈	11 ³ / ₈		6 ⁵ / ₈	11 ⁵ / ₈	
4	7 ¹ / ₈	12 ¹ / ₈		7 ³ / ₈	13 ¹ / ₈	
5	7 ⁷ / ₈	14 ³ / ₈		8 ¹ / ₈	14 ⁵ / ₈	
6	8 ⁵ / ₈	15 ⁷ / ₈		8 ⁷ / ₈	16 ¹ / ₈	
7	9 ³ / ₈	17 ³ / ₈		9 ⁵ / ₈	17 ⁵ / ₈	
8	10 ¹ / ₈	18 ¹ / ₈		10 ³ / ₈	19 ¹ / ₈	
9	10 ⁷ / ₈	20 ³ / ₈		11 ¹ / ₈	20 ⁵ / ₈	
10	11 ⁵ / ₈	21 ⁷ / ₈		11 ⁷ / ₈	22 ¹ / ₈	
11	12 ³ / ₈	23 ³ / ₈		12 ⁵ / ₈	23 ⁵ / ₈	
12	13 ¹ / ₈	24 ¹ / ₈		13 ³ / ₈	25 ¹ / ₈	
13	13 ⁷ / ₈	26 ³ / ₈		14 ¹ / ₈	26 ⁵ / ₈	
14	14 ⁵ / ₈	27 ⁷ / ₈		14 ⁷ / ₈	28 ¹ / ₈	
15	15 ³ / ₈	29 ³ / ₈		15 ⁵ / ₈	29 ⁵ / ₈	
16	16 ¹ / ₈	30 ¹ / ₈		16 ³ / ₈	31 ¹ / ₈	

* For spring-return switches when more than three and less than seven contacts close in the normal handle position, add ³/₄" to "A", and 1 ¹/₂" to "B". When seven or more contacts close in the normal handle position, add 1 ¹/₂" to "A" and 3" to "B".

Note: Removable handles are similar to fixed handles and available in all styles except radial and locked. They do not alter switch dimensions or drilling.

SHIPPING WEIGHTS

Approx weights are listed below. All weights listed apply to SB-9 switches consisting of one stage. Add 6 ounces for each additional stage.

SB-9 (1 Stage) @ 3 lbs

(This data is subject to change without notice)

Outline Dimensions

SB-10

CONTROL AND TRANSFER SWITCHES

(For estimating only)

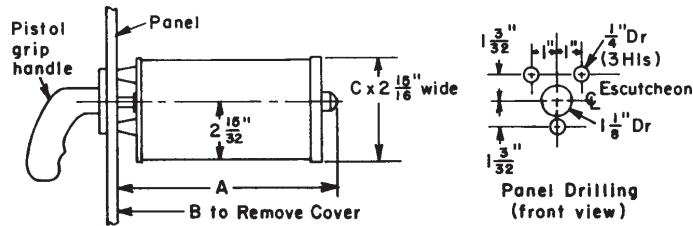

Panel-mounted SB-10 switch
(Outline 0165A6122)

No. of Stages*	Dimension in Inches					
	Standard Cover			Large Cover		
	A	B	C	A	B	C
1	6 ³ / ₄	12 ¹ / ₂	4 ¹ / ₂	7	12 ³ / ₄	4 ¹⁵ / ₁₆
2	6 ³ / ₄	12 ¹ / ₂		7	12 ³ / ₄	
3	7 ¹ / ₂	14		7 ³ / ₄	14 ¹ / ₄	
4	8 ¹ / ₄	15 ¹ / ₂		8 ¹ / ₂	15 ³ / ₄	
5	9	17		9 ¹ / ₄	17 ¹ / ₄	
6	9 ³ / ₄	18 ¹ / ₂		10	18 ³ / ₄	
7	10 ¹ / ₂	20		10 ³ / ₄	20 ¹ / ₄	
8	11 ¹ / ₄	21 ¹ / ₂		11 ¹ / ₂	21 ³ / ₄	
9	12	23		12 ¹ / ₄	23 ¹ / ₄	
10	12 ³ / ₄	24 ¹ / ₂		13	24 ³ / ₄	
11	13 ¹ / ₂	26		13 ³ / ₄	26 ¹ / ₄	
12	14 ¹ / ₄	27 ¹ / ₂		14 ¹ / ₂	27 ³ / ₄	

SHIPPING WEIGHTS

Approx weights are listed below. All weights listed apply to SB-10 switches consisting of one stage. Add 6 ounces for each additional stage.

SB-10 (1 Stage) @ 3 ¹/₂ lbs

(This data is subject to change without notice)

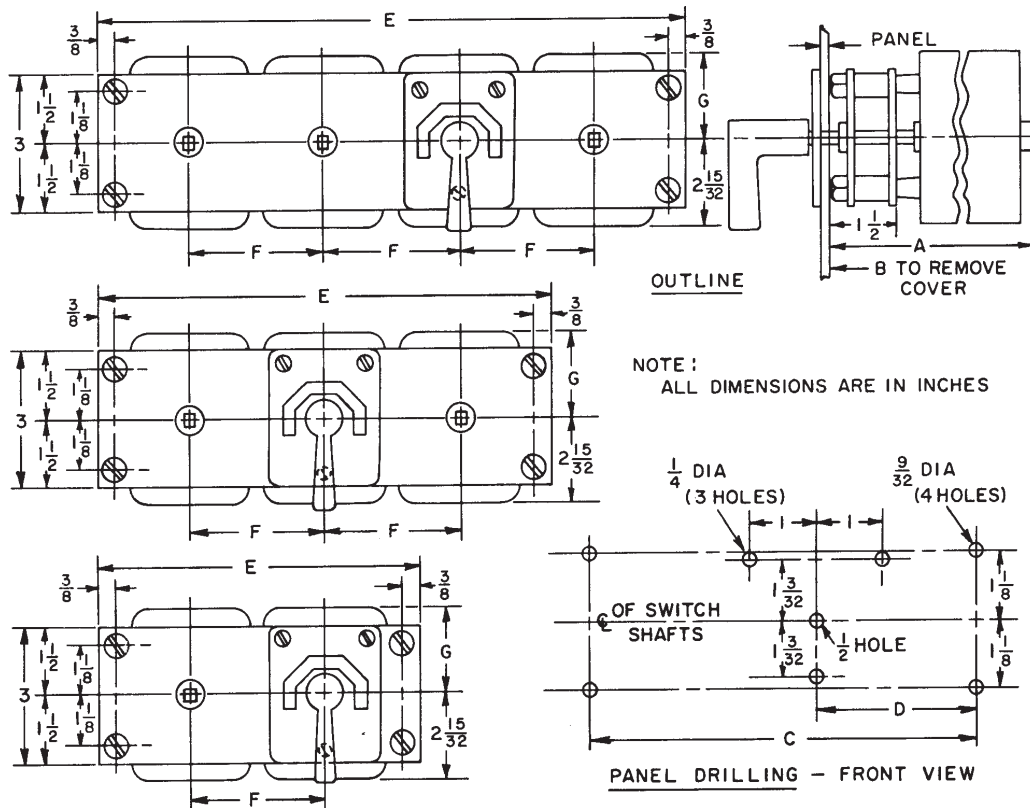

No. of Stages	A*	B*
1	5 1/16	7 7/16
2	5 13/16	8 15/16
3	6 9/16	10 7/16
4	7 5/16	11 15/16
5	8 1/16	13 7/16
6	8 13/16	14 15/16
7	9 9/16	16 7/16
8	10 5/16	17 15/16
9	11 1/16	19 7/16
10	11 13/16	20 15/16
11	12 9/16	22 7/16
12	13 5/16	23 15/16
13	14 1/16	25 7/16
14	14 13/16	26 15/16
15	15 9/16	28 7/16
16	16 5/16	29 15/16

TWO SWITCH TANDEM SB-1
Gear-operated (360° rotation)

THREE SWITCH TANDEM SB-1
Gear-operated (360° rotation)

FOUR SWITCH TANDEM SB-1
Gear-operated (360° rotation)

C	D	E	F	G
7 1/2	2	8 1/4	3 1/2	2" FOR SMALL COVER 2 1/2" FOR LARGE COVER

(This data is subject to change without notice)

* Add 1/4 to A & B Dimensions for Large Cover

SB-switch with Yale or Kirk Lock above the switch. For "A" and "B", use standard dimensions plus "D", depending on panel thickness.

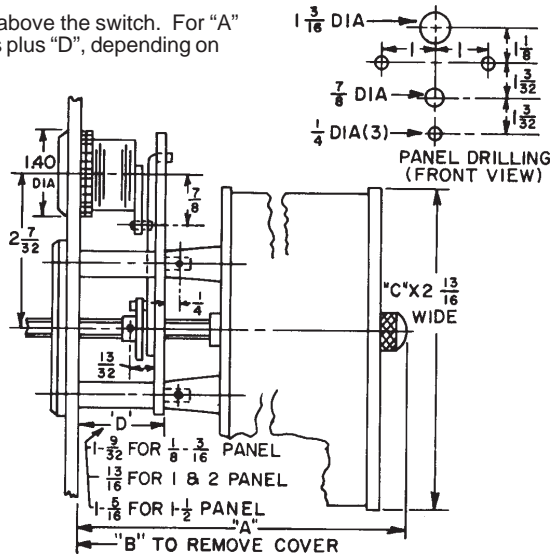

SB-9 switches
Standard dimensions in inches

No. of Stages	Standard Cover 12 Wires Out Top and 24 Wires Out Bottom			Large Cover 24 Wires Out Top and Bottom		
	A	B	C	A	B	C
1	4 7/8	8 3/8	4 1/2	5 1/8	8 5/8	4 15/16
2	5 5/8	9 7/8		5 7/8	10 1/8	
3	6 3/8	11 3/8		6 5/8	11 5/8	
4	7 1/8	12 7/8		7 3/8	13 1/8	
5	7 7/8	14 3/8		8 1/8	14 5/8	
6	8 3/8	15 7/8		8 7/8	16 1/8	
7	9 3/8	17 3/8		9 5/8	17 5/8	
8	10 1/8	18 7/8		10 3/8	19 1/8	
9	10 7/8	20 3/8		11 1/8	20 5/8	
10	11 5/8	21 7/8		11 7/8	22 1/8	
11	12 3/8	22 3/8		12 5/8	23 5/8	
12	13 1/8	24 7/8		13 3/8	25 1/8	
13	13 7/8	26 3/8		14 1/8	26 5/8	
14	14 5/8	27 7/8		14 7/8	28 1/8	
15	15 3/8	29 3/8		15 5/8	29 5/8	
16	16 1/8	30 7/8		16 3/8	31 1/8	

(This data subject to change without notice)

Contact Diagrams SBM

Fig #	DESCRIPTION	ESCUTCHEON & CONTACT DIAGRAM	WIRING DIAGRAM
1	VOLTMETER SWITCH Double-pole, single-throw Model No. 10AA001 Knurled handle		
2	VOLTMETER SWITCH Double-pole, double-throw Model No. 10AA002 Knurled handle		
3	VOLTMETER SWITCH Phase-to-phase or phase-to-neutral Model No. 10AA004 Knurled handle		<p>3-phase 3-wire</p> <p>3-phase, 4-wire (future alternate connection)</p>
4	VOLTMETER SWITCH Four circuits, two wires Model No. 10AA005 Knurled handle		

X In all contact diagrams denotes contacts closed

Contact Diagrams SBM

Fig #	DESCRIPTION	ESCUTCHEON & CONTACT DIAGRAM	WIRING DIAGRAM
5	VOLTMETER SWITCH Two three-phase, three-wire circuits <i>Model No. 10AA007</i> Knurled handle		
6	VOLTMETER TRANSFER SWITCH Three-phase, transfers four wires phase-to-neutral <i>Model No. 10AA003</i> Knurled handle		
7	VOLTMETER TRANSFER SWITCH Three-phase, transfers four wires phase-to-phase and phase-to-neutral <i>Model No. 10AA006</i> Knurled handle		
8	AMMETER TRANSFER SWITCH Three CT's (connect at end of secondary) <i>Model No. 10AA008</i> Knurled handle		

X In all contact diagrams denotes contacts closed

Contact Diagrams SBM

Fig #	DESCRIPTION	ESCUTCHEON & CONTACT DIAGRAM	WIRING DIAGRAM																																																																																																																																																																								
9	AMMETER TRANSFER SWITCH Three CT's with off (connect at end of secondary) <i>Model No. 10AA009</i> Knurled handle	<table border="1"> <tr> <td colspan="2">AMMETER</td> <td colspan="12">CONTACTS</td> </tr> <tr> <td colspan="2">OFF</td> <td colspan="2">HANDLE</td> <td colspan="10"></td> </tr> <tr> <td colspan="2"></td> <td colspan="2">END</td> <td colspan="10"></td> </tr> <tr> <td>3</td> <td>0</td> <td>1</td> <td>2</td> <td>3</td> <td>4</td> <td>5</td> <td>6</td> <td>7</td> <td>8</td> <td>9</td> <td>10</td> <td>11</td> <td>12</td> </tr> <tr> <td colspan="2"></td> <td>ODD</td> <td>EVEN</td> <td>*</td> <td>*</td> <td>*</td> <td>*</td> <td>*</td> <td>*</td> <td>*</td> <td>*</td> <td>*</td> <td>OFF</td> </tr> <tr> <td colspan="2"></td> <td>1-15</td> <td>1-15</td> <td>X</td> <td>X</td> <td>X</td> <td>X</td> <td>X</td> <td>X</td> <td>X</td> <td>X</td> <td>X</td> <td>X</td> </tr> <tr> <td colspan="2"></td> <td>1-15</td> <td>1-15</td> <td>X</td> <td>X</td> <td>X</td> <td>X</td> <td>X</td> <td>X</td> <td>X</td> <td>X</td> <td>X</td> <td>X</td> </tr> <tr> <td colspan="2"></td> <td>1-15</td> <td>1-15</td> <td>X</td> <td>X</td> <td>X</td> <td>X</td> <td>X</td> <td>X</td> <td>X</td> <td>X</td> <td>X</td> <td>X</td> </tr> <tr> <td colspan="2"></td> <td>1-15</td> <td>1-15</td> <td>X</td> <td>X</td> <td>X</td> <td>X</td> <td>X</td> <td>X</td> <td>X</td> <td>X</td> <td>X</td> <td>X</td> </tr> </table>	AMMETER		CONTACTS												OFF		HANDLE														END												3	0	1	2	3	4	5	6	7	8	9	10	11	12			ODD	EVEN	*	*	*	*	*	*	*	*	*	OFF			1-15	1-15	X	X	X	X	X	X	X	X	X	X			1-15	1-15	X	X	X	X	X	X	X	X	X	X			1-15	1-15	X	X	X	X	X	X	X	X	X	X			1-15	1-15	X	X	X	X	X	X	X	X	X	X																																											
AMMETER		CONTACTS																																																																																																																																																																									
OFF		HANDLE																																																																																																																																																																									
		END																																																																																																																																																																									
3	0	1	2	3	4	5	6	7	8	9	10	11	12																																																																																																																																																														
		ODD	EVEN	*	*	*	*	*	*	*	*	*	OFF																																																																																																																																																														
		1-15	1-15	X	X	X	X	X	X	X	X	X	X																																																																																																																																																														
		1-15	1-15	X	X	X	X	X	X	X	X	X	X																																																																																																																																																														
		1-15	1-15	X	X	X	X	X	X	X	X	X	X																																																																																																																																																														
		1-15	1-15	X	X	X	X	X	X	X	X	X	X																																																																																																																																																														
10	AMMETER TRANSFER SWITCH Three independent circuits <i>Model No. 10AA010</i> Knurled handle	<table border="1"> <tr> <td colspan="2">AMMETER</td> <td colspan="12">CONTACTS</td> </tr> <tr> <td colspan="2">2</td> <td colspan="2">HANDLE</td> <td colspan="10"></td> </tr> <tr> <td colspan="2"></td> <td colspan="2">END</td> <td colspan="10"></td> </tr> <tr> <td>-</td> <td>0</td> <td>1</td> <td>2</td> <td>3</td> <td>4</td> <td>5</td> <td>6</td> <td>7</td> <td>8</td> <td>9</td> <td>10</td> <td>11</td> <td>12</td> </tr> <tr> <td colspan="2"></td> <td>ODD</td> <td>EVEN</td> <td>*</td> <td>*</td> <td>*</td> <td>*</td> <td>*</td> <td>*</td> <td>*</td> <td>*</td> <td>*</td> <td>-</td> </tr> <tr> <td colspan="2"></td> <td>1-15</td> <td>1-15</td> <td>X</td> <td>X</td> <td>X</td> <td>X</td> <td>X</td> <td>X</td> <td>X</td> <td>X</td> <td>X</td> <td>X</td> </tr> <tr> <td colspan="2"></td> <td>1-15</td> <td>1-15</td> <td></td> <td></td> <td></td> <td></td> <td></td> <td></td> <td></td> <td></td> <td></td> <td>X</td> </tr> <tr> <td colspan="2"></td> <td>1-15</td> <td>1-15</td> <td></td> <td></td> <td></td> <td></td> <td></td> <td></td> <td></td> <td></td> <td></td> <td>X</td> </tr> <tr> <td colspan="2"></td> <td>1-15</td> <td>1-15</td> <td></td> <td></td> <td></td> <td></td> <td></td> <td></td> <td></td> <td></td> <td></td> <td>X</td> </tr> <tr> <td colspan="2"></td> <td>1-15</td> <td>1-15</td> <td>X</td> <td>X</td> <td>X</td> <td>X</td> <td>X</td> <td>X</td> <td>X</td> <td>X</td> <td>X</td> <td>X</td> </tr> <tr> <td colspan="2"></td> <td>1-15</td> <td>1-15</td> <td>X</td> <td>X</td> <td>X</td> <td>X</td> <td>X</td> <td>X</td> <td>X</td> <td>X</td> <td>X</td> <td>X</td> </tr> <tr> <td colspan="2"></td> <td>1-15</td> <td>1-15</td> <td>X</td> <td>X</td> <td>X</td> <td>X</td> <td>X</td> <td>X</td> <td>X</td> <td>X</td> <td>X</td> <td>X</td> </tr> </table>	AMMETER		CONTACTS												2		HANDLE														END												-	0	1	2	3	4	5	6	7	8	9	10	11	12			ODD	EVEN	*	*	*	*	*	*	*	*	*	-			1-15	1-15	X	X	X	X	X	X	X	X	X	X			1-15	1-15										X			1-15	1-15										X			1-15	1-15										X			1-15	1-15	X	X	X	X	X	X	X	X	X	X			1-15	1-15	X	X	X	X	X	X	X	X	X	X			1-15	1-15	X	X	X	X	X	X	X	X	X	X	
AMMETER		CONTACTS																																																																																																																																																																									
2		HANDLE																																																																																																																																																																									
		END																																																																																																																																																																									
-	0	1	2	3	4	5	6	7	8	9	10	11	12																																																																																																																																																														
		ODD	EVEN	*	*	*	*	*	*	*	*	*	-																																																																																																																																																														
		1-15	1-15	X	X	X	X	X	X	X	X	X	X																																																																																																																																																														
		1-15	1-15										X																																																																																																																																																														
		1-15	1-15										X																																																																																																																																																														
		1-15	1-15										X																																																																																																																																																														
		1-15	1-15	X	X	X	X	X	X	X	X	X	X																																																																																																																																																														
		1-15	1-15	X	X	X	X	X	X	X	X	X	X																																																																																																																																																														
		1-15	1-15	X	X	X	X	X	X	X	X	X	X																																																																																																																																																														
11	AMMETER TRANSFER SWITCH Two CT's (connect at end of secondary) <i>Model No. 10AA011</i> Knurled handle	<table border="1"> <tr> <td colspan="2">AMMETER</td> <td colspan="12">CONTACTS</td> </tr> <tr> <td colspan="2">2</td> <td colspan="2">HANDLE</td> <td colspan="10"></td> </tr> <tr> <td colspan="2"></td> <td colspan="2">END</td> <td colspan="10"></td> </tr> <tr> <td>-</td> <td>0</td> <td>1</td> <td>2</td> <td>3</td> <td>4</td> <td>5</td> <td>6</td> <td>7</td> <td>8</td> <td>9</td> <td>10</td> <td>11</td> <td>12</td> </tr> <tr> <td colspan="2"></td> <td>ODD</td> <td>EVEN</td> <td>*</td> <td>*</td> <td>*</td> <td>*</td> <td>*</td> <td>*</td> <td>*</td> <td>*</td> <td>*</td> <td>-</td> </tr> <tr> <td colspan="2"></td> <td>1-15</td> <td>1-15</td> <td>X</td> <td>X</td> <td>X</td> <td>X</td> <td>X</td> <td>X</td> <td>X</td> <td>X</td> <td>X</td> <td>X</td> </tr> <tr> <td colspan="2"></td> <td>1-15</td> <td>1-15</td> <td></td> <td></td> <td></td> <td></td> <td></td> <td></td> <td></td> <td></td> <td></td> <td>X</td> </tr> <tr> <td colspan="2"></td> <td>1-15</td> <td>1-15</td> <td></td> <td></td> <td></td> <td></td> <td></td> <td></td> <td></td> <td></td> <td></td> <td>X</td> </tr> <tr> <td colspan="2"></td> <td>1-15</td> <td>1-15</td> <td>X</td> <td>X</td> <td>X</td> <td>X</td> <td>X</td> <td>X</td> <td>X</td> <td>X</td> <td>X</td> <td>X</td> </tr> <tr> <td colspan="2"></td> <td>1-15</td> <td>1-15</td> <td>X</td> <td>X</td> <td>X</td> <td>X</td> <td>X</td> <td>X</td> <td>X</td> <td>X</td> <td>X</td> <td>X</td> </tr> </table>	AMMETER		CONTACTS												2		HANDLE														END												-	0	1	2	3	4	5	6	7	8	9	10	11	12			ODD	EVEN	*	*	*	*	*	*	*	*	*	-			1-15	1-15	X	X	X	X	X	X	X	X	X	X			1-15	1-15										X			1-15	1-15										X			1-15	1-15	X	X	X	X	X	X	X	X	X	X			1-15	1-15	X	X	X	X	X	X	X	X	X	X																													
AMMETER		CONTACTS																																																																																																																																																																									
2		HANDLE																																																																																																																																																																									
		END																																																																																																																																																																									
-	0	1	2	3	4	5	6	7	8	9	10	11	12																																																																																																																																																														
		ODD	EVEN	*	*	*	*	*	*	*	*	*	-																																																																																																																																																														
		1-15	1-15	X	X	X	X	X	X	X	X	X	X																																																																																																																																																														
		1-15	1-15										X																																																																																																																																																														
		1-15	1-15										X																																																																																																																																																														
		1-15	1-15	X	X	X	X	X	X	X	X	X	X																																																																																																																																																														
		1-15	1-15	X	X	X	X	X	X	X	X	X	X																																																																																																																																																														
12	AMMETER TRANSFER SWITCH Three independent circuits with off (connect at end of secondary) <i>Model No. 10AA012</i> Knurled handle	<table border="1"> <tr> <td colspan="2">AMMETER</td> <td colspan="12">CONTACTS</td> </tr> <tr> <td colspan="2">OFF</td> <td colspan="2">HANDLE</td> <td colspan="10"></td> </tr> <tr> <td colspan="2"></td> <td colspan="2">END</td> <td colspan="10"></td> </tr> <tr> <td>3</td> <td>0</td> <td>1</td> <td>2</td> <td>3</td> <td>4</td> <td>5</td> <td>6</td> <td>7</td> <td>8</td> <td>9</td> <td>10</td> <td>11</td> <td>12</td> </tr> <tr> <td colspan="2"></td> <td>ODD</td> <td>EVEN</td> <td>*</td> <td>*</td> <td>*</td> <td>*</td> <td>*</td> <td>*</td> <td>*</td> <td>*</td> <td>*</td> <td>OFF</td> </tr> <tr> <td colspan="2"></td> <td>1-15</td> <td>1-15</td> <td>X</td> <td>X</td> <td>X</td> <td>X</td> <td>X</td> <td>X</td> <td>X</td> <td>X</td> <td>X</td> <td>X</td> </tr> <tr> <td colspan="2"></td> <td>1-15</td> <td>1-15</td> <td>X</td> <td>X</td> <td>X</td> <td>X</td> <td>X</td> <td>X</td> <td>X</td> <td>X</td> <td>X</td> <td>X</td> </tr> <tr> <td colspan="2"></td> <td>1-15</td> <td>1-15</td> <td>X</td> <td>X</td> <td>X</td> <td>X</td> <td>X</td> <td>X</td> <td>X</td> <td>X</td> <td>X</td> <td>X</td> </tr> <tr> <td colspan="2"></td> <td>1-15</td> <td>1-15</td> <td>X</td> <td>X</td> <td>X</td> <td>X</td> <td>X</td> <td>X</td> <td>X</td> <td>X</td> <td>X</td> <td>X</td> </tr> </table>	AMMETER		CONTACTS												OFF		HANDLE														END												3	0	1	2	3	4	5	6	7	8	9	10	11	12			ODD	EVEN	*	*	*	*	*	*	*	*	*	OFF			1-15	1-15	X	X	X	X	X	X	X	X	X	X			1-15	1-15	X	X	X	X	X	X	X	X	X	X			1-15	1-15	X	X	X	X	X	X	X	X	X	X			1-15	1-15	X	X	X	X	X	X	X	X	X	X																																											
AMMETER		CONTACTS																																																																																																																																																																									
OFF		HANDLE																																																																																																																																																																									
		END																																																																																																																																																																									
3	0	1	2	3	4	5	6	7	8	9	10	11	12																																																																																																																																																														
		ODD	EVEN	*	*	*	*	*	*	*	*	*	OFF																																																																																																																																																														
		1-15	1-15	X	X	X	X	X	X	X	X	X	X																																																																																																																																																														
		1-15	1-15	X	X	X	X	X	X	X	X	X	X																																																																																																																																																														
		1-15	1-15	X	X	X	X	X	X	X	X	X	X																																																																																																																																																														
		1-15	1-15	X	X	X	X	X	X	X	X	X	X																																																																																																																																																														

X In all contact diagrams denotes contacts closed

Contact Diagrams SBM

Fig #	DESCRIPTION	ESCUTCHEON & CONTACT DIAGRAM	WIRING DIAGRAM																																																																																																																																																																																																																																																																																																																													
13	AMMETER TRANSFER SWITCH Three independent circuits with off Model No. 10AA013 Knurled handle	<table border="1"> <tr> <td colspan="2">AMMETER</td> <td colspan="12">CONTACTS HANDLE END</td> </tr> <tr> <td colspan="2">OFF</td> <td>ODD</td> <td colspan="11">EVEN</td> <td>OFF</td> </tr> <tr> <td>3</td> <td>0</td> <td>1</td> <td>X</td> <td>X</td> <td>X</td> <td>X</td> <td>X</td> <td>X</td> <td>X</td> <td>X</td> <td>X</td> <td>X</td> <td>X</td> <td>X</td> <td>X</td> <td>X</td> <td>X</td> <td>X</td> <td>X</td> <td>X</td> <td>X</td> <td>X</td> <td>X</td> </tr> <tr> <td>2</td> <td></td> <td>2</td> <td>X</td> <td>X</td> <td>X</td> <td>X</td> <td>X</td> <td>X</td> <td>X</td> <td>X</td> <td>X</td> <td>X</td> <td>X</td> <td>X</td> <td>X</td> <td>X</td> <td>X</td> <td>X</td> <td>X</td> <td>X</td> <td>X</td> <td>X</td> <td>X</td> </tr> <tr> <td></td> <td></td> <td>3</td> <td>X</td> <td>X</td> <td>X</td> <td>X</td> <td>X</td> <td>X</td> <td>X</td> <td>X</td> <td>X</td> <td>X</td> <td>X</td> <td>X</td> <td>X</td> <td>X</td> <td>X</td> <td>X</td> <td>X</td> <td>X</td> <td>X</td> <td>X</td> <td>X</td> </tr> <tr> <td></td> <td></td> <td>4</td> <td>X</td> <td>X</td> <td>X</td> <td>X</td> <td>X</td> <td>X</td> <td>X</td> <td>X</td> <td>X</td> <td>X</td> <td>X</td> <td>X</td> <td>X</td> <td>X</td> <td>X</td> <td>X</td> <td>X</td> <td>X</td> <td>X</td> <td>X</td> <td>X</td> </tr> <tr> <td></td> <td></td> <td>5</td> <td>X</td> <td>X</td> <td>X</td> <td>X</td> <td>X</td> <td>X</td> <td>X</td> <td>X</td> <td>X</td> <td>X</td> <td>X</td> <td>X</td> <td>X</td> <td>X</td> <td>X</td> <td>X</td> <td>X</td> <td>X</td> <td>X</td> <td>X</td> <td>X</td> </tr> <tr> <td></td> <td></td> <td>6</td> <td>X</td> <td>X</td> <td>X</td> <td>X</td> <td>X</td> <td>X</td> <td>X</td> <td>X</td> <td>X</td> <td>X</td> <td>X</td> <td>X</td> <td>X</td> <td>X</td> <td>X</td> <td>X</td> <td>X</td> <td>X</td> <td>X</td> <td>X</td> <td>X</td> </tr> <tr> <td></td> <td></td> <td>7</td> <td>X</td> <td>X</td> <td>X</td> <td>X</td> <td>X</td> <td>X</td> <td>X</td> <td>X</td> <td>X</td> <td>X</td> <td>X</td> <td>X</td> <td>X</td> <td>X</td> <td>X</td> <td>X</td> <td>X</td> <td>X</td> <td>X</td> <td>X</td> <td>X</td> </tr> <tr> <td></td> <td></td> <td>8</td> <td>X</td> <td>X</td> <td>X</td> <td>X</td> <td>X</td> <td>X</td> <td>X</td> <td>X</td> <td>X</td> <td>X</td> <td>X</td> <td>X</td> <td>X</td> <td>X</td> <td>X</td> <td>X</td> <td>X</td> <td>X</td> <td>X</td> <td>X</td> <td>X</td> </tr> <tr> <td></td> <td></td> <td>9</td> <td>X</td> <td>X</td> <td>X</td> <td>X</td> <td>X</td> <td>X</td> <td>X</td> <td>X</td> <td>X</td> <td>X</td> <td>X</td> <td>X</td> <td>X</td> <td>X</td> <td>X</td> <td>X</td> <td>X</td> <td>X</td> <td>X</td> <td>X</td> <td>X</td> </tr> </table>	AMMETER		CONTACTS HANDLE END												OFF		ODD	EVEN											OFF	3	0	1	X	X	X	X	X	X	X	X	X	X	X	X	X	X	X	X	X	X	X	X	X	2		2	X	X	X	X	X	X	X	X	X	X	X	X	X	X	X	X	X	X	X	X	X			3	X	X	X	X	X	X	X	X	X	X	X	X	X	X	X	X	X	X	X	X	X			4	X	X	X	X	X	X	X	X	X	X	X	X	X	X	X	X	X	X	X	X	X			5	X	X	X	X	X	X	X	X	X	X	X	X	X	X	X	X	X	X	X	X	X			6	X	X	X	X	X	X	X	X	X	X	X	X	X	X	X	X	X	X	X	X	X			7	X	X	X	X	X	X	X	X	X	X	X	X	X	X	X	X	X	X	X	X	X			8	X	X	X	X	X	X	X	X	X	X	X	X	X	X	X	X	X	X	X	X	X			9	X	X	X	X	X	X	X	X	X	X	X	X	X	X	X	X	X	X	X	X	X																																																																									
AMMETER		CONTACTS HANDLE END																																																																																																																																																																																																																																																																																																																														
OFF		ODD	EVEN											OFF																																																																																																																																																																																																																																																																																																																		
3	0	1	X	X	X	X	X	X	X	X	X	X	X	X	X	X	X	X	X	X	X	X	X																																																																																																																																																																																																																																																																																																									
2		2	X	X	X	X	X	X	X	X	X	X	X	X	X	X	X	X	X	X	X	X	X																																																																																																																																																																																																																																																																																																									
		3	X	X	X	X	X	X	X	X	X	X	X	X	X	X	X	X	X	X	X	X	X																																																																																																																																																																																																																																																																																																									
		4	X	X	X	X	X	X	X	X	X	X	X	X	X	X	X	X	X	X	X	X	X																																																																																																																																																																																																																																																																																																									
		5	X	X	X	X	X	X	X	X	X	X	X	X	X	X	X	X	X	X	X	X	X																																																																																																																																																																																																																																																																																																									
		6	X	X	X	X	X	X	X	X	X	X	X	X	X	X	X	X	X	X	X	X	X																																																																																																																																																																																																																																																																																																									
		7	X	X	X	X	X	X	X	X	X	X	X	X	X	X	X	X	X	X	X	X	X																																																																																																																																																																																																																																																																																																									
		8	X	X	X	X	X	X	X	X	X	X	X	X	X	X	X	X	X	X	X	X	X																																																																																																																																																																																																																																																																																																									
		9	X	X	X	X	X	X	X	X	X	X	X	X	X	X	X	X	X	X	X	X	X																																																																																																																																																																																																																																																																																																									
14	AMMETER-VOLTMETER TRANSFER SWITCH Three-phase, four wires phase-to-neutral, plus three current transformers (connect at end of secondary) Model No. 10AA017 Knurled handle	<table border="1"> <tr> <td colspan="2">AMMETER VOLTMETER</td> <td colspan="12">CONTACTS HANDLE END</td> </tr> <tr> <td colspan="2">OFF</td> <td>ODD</td> <td colspan="11">EVEN</td> <td>OFF</td> </tr> <tr> <td>3</td> <td>0</td> <td>1</td> <td>X</td> <td>X</td> <td>X</td> <td>X</td> <td>X</td> <td>X</td> <td>X</td> <td>X</td> <td>X</td> <td>X</td> <td>X</td> <td>X</td> <td>X</td> <td>X</td> <td>X</td> <td>X</td> <td>X</td> <td>X</td> <td>X</td> <td>X</td> <td>X</td> </tr> <tr> <td>2</td> <td></td> <td>2</td> <td>X</td> <td>X</td> <td>X</td> <td>X</td> <td>X</td> <td>X</td> <td>X</td> <td>X</td> <td>X</td> <td>X</td> <td>X</td> <td>X</td> <td>X</td> <td>X</td> <td>X</td> <td>X</td> <td>X</td> <td>X</td> <td>X</td> <td>X</td> <td>X</td> </tr> <tr> <td></td> <td></td> <td>3</td> <td>X</td> <td>X</td> <td>X</td> <td>X</td> <td>X</td> <td>X</td> <td>X</td> <td>X</td> <td>X</td> <td>X</td> <td>X</td> <td>X</td> <td>X</td> <td>X</td> <td>X</td> <td>X</td> <td>X</td> <td>X</td> <td>X</td> <td>X</td> <td>X</td> </tr> <tr> <td></td> <td></td> <td>4</td> <td>X</td> <td>X</td> <td>X</td> <td>X</td> <td>X</td> <td>X</td> <td>X</td> <td>X</td> <td>X</td> <td>X</td> <td>X</td> <td>X</td> <td>X</td> <td>X</td> <td>X</td> <td>X</td> <td>X</td> <td>X</td> <td>X</td> <td>X</td> <td>X</td> </tr> <tr> <td></td> <td></td> <td>5</td> <td>X</td> <td>X</td> <td>X</td> <td>X</td> <td>X</td> <td>X</td> <td>X</td> <td>X</td> <td>X</td> <td>X</td> <td>X</td> <td>X</td> <td>X</td> <td>X</td> <td>X</td> <td>X</td> <td>X</td> <td>X</td> <td>X</td> <td>X</td> <td>X</td> </tr> <tr> <td></td> <td></td> <td>6</td> <td>X</td> <td>X</td> <td>X</td> <td>X</td> <td>X</td> <td>X</td> <td>X</td> <td>X</td> <td>X</td> <td>X</td> <td>X</td> <td>X</td> <td>X</td> <td>X</td> <td>X</td> <td>X</td> <td>X</td> <td>X</td> <td>X</td> <td>X</td> <td>X</td> </tr> <tr> <td></td> <td></td> <td>7</td> <td>X</td> <td>X</td> <td>X</td> <td>X</td> <td>X</td> <td>X</td> <td>X</td> <td>X</td> <td>X</td> <td>X</td> <td>X</td> <td>X</td> <td>X</td> <td>X</td> <td>X</td> <td>X</td> <td>X</td> <td>X</td> <td>X</td> <td>X</td> <td>X</td> </tr> <tr> <td></td> <td></td> <td>8</td> <td>X</td> <td>X</td> <td>X</td> <td>X</td> <td>X</td> <td>X</td> <td>X</td> <td>X</td> <td>X</td> <td>X</td> <td>X</td> <td>X</td> <td>X</td> <td>X</td> <td>X</td> <td>X</td> <td>X</td> <td>X</td> <td>X</td> <td>X</td> <td>X</td> </tr> <tr> <td></td> <td></td> <td>9</td> <td>X</td> <td>X</td> <td>X</td> <td>X</td> <td>X</td> <td>X</td> <td>X</td> <td>X</td> <td>X</td> <td>X</td> <td>X</td> <td>X</td> <td>X</td> <td>X</td> <td>X</td> <td>X</td> <td>X</td> <td>X</td> <td>X</td> <td>X</td> <td>X</td> </tr> <tr> <td></td> <td></td> <td>10</td> <td>X</td> <td>X</td> <td>X</td> <td>X</td> <td>X</td> <td>X</td> <td>X</td> <td>X</td> <td>X</td> <td>X</td> <td>X</td> <td>X</td> <td>X</td> <td>X</td> <td>X</td> <td>X</td> <td>X</td> <td>X</td> <td>X</td> <td>X</td> <td>X</td> </tr> <tr> <td></td> <td></td> <td>11</td> <td>X</td> <td>X</td> <td>X</td> <td>X</td> <td>X</td> <td>X</td> <td>X</td> <td>X</td> <td>X</td> <td>X</td> <td>X</td> <td>X</td> <td>X</td> <td>X</td> <td>X</td> <td>X</td> <td>X</td> <td>X</td> <td>X</td> <td>X</td> <td>X</td> </tr> <tr> <td></td> <td></td> <td>12</td> <td>X</td> <td>X</td> <td>X</td> <td>X</td> <td>X</td> <td>X</td> <td>X</td> <td>X</td> <td>X</td> <td>X</td> <td>X</td> <td>X</td> <td>X</td> <td>X</td> <td>X</td> <td>X</td> <td>X</td> <td>X</td> <td>X</td> <td>X</td> <td>X</td> </tr> </table>	AMMETER VOLTMETER		CONTACTS HANDLE END												OFF		ODD	EVEN											OFF	3	0	1	X	X	X	X	X	X	X	X	X	X	X	X	X	X	X	X	X	X	X	X	X	2		2	X	X	X	X	X	X	X	X	X	X	X	X	X	X	X	X	X	X	X	X	X			3	X	X	X	X	X	X	X	X	X	X	X	X	X	X	X	X	X	X	X	X	X			4	X	X	X	X	X	X	X	X	X	X	X	X	X	X	X	X	X	X	X	X	X			5	X	X	X	X	X	X	X	X	X	X	X	X	X	X	X	X	X	X	X	X	X			6	X	X	X	X	X	X	X	X	X	X	X	X	X	X	X	X	X	X	X	X	X			7	X	X	X	X	X	X	X	X	X	X	X	X	X	X	X	X	X	X	X	X	X			8	X	X	X	X	X	X	X	X	X	X	X	X	X	X	X	X	X	X	X	X	X			9	X	X	X	X	X	X	X	X	X	X	X	X	X	X	X	X	X	X	X	X	X			10	X	X	X	X	X	X	X	X	X	X	X	X	X	X	X	X	X	X	X	X	X			11	X	X	X	X	X	X	X	X	X	X	X	X	X	X	X	X	X	X	X	X	X			12	X	X	X	X	X	X	X	X	X	X	X	X	X	X	X	X	X	X	X	X	X	
AMMETER VOLTMETER		CONTACTS HANDLE END																																																																																																																																																																																																																																																																																																																														
OFF		ODD	EVEN											OFF																																																																																																																																																																																																																																																																																																																		
3	0	1	X	X	X	X	X	X	X	X	X	X	X	X	X	X	X	X	X	X	X	X	X																																																																																																																																																																																																																																																																																																									
2		2	X	X	X	X	X	X	X	X	X	X	X	X	X	X	X	X	X	X	X	X	X																																																																																																																																																																																																																																																																																																									
		3	X	X	X	X	X	X	X	X	X	X	X	X	X	X	X	X	X	X	X	X	X																																																																																																																																																																																																																																																																																																									
		4	X	X	X	X	X	X	X	X	X	X	X	X	X	X	X	X	X	X	X	X	X																																																																																																																																																																																																																																																																																																									
		5	X	X	X	X	X	X	X	X	X	X	X	X	X	X	X	X	X	X	X	X	X																																																																																																																																																																																																																																																																																																									
		6	X	X	X	X	X	X	X	X	X	X	X	X	X	X	X	X	X	X	X	X	X																																																																																																																																																																																																																																																																																																									
		7	X	X	X	X	X	X	X	X	X	X	X	X	X	X	X	X	X	X	X	X	X																																																																																																																																																																																																																																																																																																									
		8	X	X	X	X	X	X	X	X	X	X	X	X	X	X	X	X	X	X	X	X	X																																																																																																																																																																																																																																																																																																									
		9	X	X	X	X	X	X	X	X	X	X	X	X	X	X	X	X	X	X	X	X	X																																																																																																																																																																																																																																																																																																									
		10	X	X	X	X	X	X	X	X	X	X	X	X	X	X	X	X	X	X	X	X	X																																																																																																																																																																																																																																																																																																									
		11	X	X	X	X	X	X	X	X	X	X	X	X	X	X	X	X	X	X	X	X	X																																																																																																																																																																																																																																																																																																									
		12	X	X	X	X	X	X	X	X	X	X	X	X	X	X	X	X	X	X	X	X	X																																																																																																																																																																																																																																																																																																									
15	AMMETER-VOLTMETER TRANSFER SWITCH Three-phase, three wires phase-to-phase, plus three independent current transformer circuits Model No. 10AA014 Knurled handle	<table border="1"> <tr> <td colspan="2">AMMETER VOLTMETER</td> <td colspan="12">CONTACTS HANDLE END</td> </tr> <tr> <td colspan="2">OFF</td> <td>ODD</td> <td colspan="11">EVEN</td> <td>OFF</td> </tr> <tr> <td>3</td> <td>0</td> <td>1</td> <td>X</td> <td>X</td> <td>X</td> <td>X</td> <td>X</td> <td>X</td> <td>X</td> <td>X</td> <td>X</td> <td>X</td> <td>X</td> <td>X</td> <td>X</td> <td>X</td> <td>X</td> <td>X</td> <td>X</td> <td>X</td> <td>X</td> <td>X</td> <td>X</td> </tr> <tr> <td>2</td> <td></td> <td>2</td> <td>X</td> <td>X</td> <td>X</td> <td>X</td> <td>X</td> <td>X</td> <td>X</td> <td>X</td> <td>X</td> <td>X</td> <td>X</td> <td>X</td> <td>X</td> <td>X</td> <td>X</td> <td>X</td> <td>X</td> <td>X</td> <td>X</td> <td>X</td> <td>X</td> </tr> <tr> <td></td> <td></td> <td>3</td> <td>X</td> <td>X</td> <td>X</td> <td>X</td> <td>X</td> <td>X</td> <td>X</td> <td>X</td> <td>X</td> <td>X</td> <td>X</td> <td>X</td> <td>X</td> <td>X</td> <td>X</td> <td>X</td> <td>X</td> <td>X</td> <td>X</td> <td>X</td> <td>X</td> </tr> <tr> <td></td> <td></td> <td>4</td> <td>X</td> <td>X</td> <td>X</td> <td>X</td> <td>X</td> <td>X</td> <td>X</td> <td>X</td> <td>X</td> <td>X</td> <td>X</td> <td>X</td> <td>X</td> <td>X</td> <td>X</td> <td>X</td> <td>X</td> <td>X</td> <td>X</td> <td>X</td> <td>X</td> </tr> <tr> <td></td> <td></td> <td>5</td> <td>X</td> <td>X</td> <td>X</td> <td>X</td> <td>X</td> <td>X</td> <td>X</td> <td>X</td> <td>X</td> <td>X</td> <td>X</td> <td>X</td> <td>X</td> <td>X</td> <td>X</td> <td>X</td> <td>X</td> <td>X</td> <td>X</td> <td>X</td> <td>X</td> </tr> <tr> <td></td> <td></td> <td>6</td> <td>X</td> <td>X</td> <td>X</td> <td>X</td> <td>X</td> <td>X</td> <td>X</td> <td>X</td> <td>X</td> <td>X</td> <td>X</td> <td>X</td> <td>X</td> <td>X</td> <td>X</td> <td>X</td> <td>X</td> <td>X</td> <td>X</td> <td>X</td> <td>X</td> </tr> <tr> <td></td> <td></td> <td>7</td> <td>X</td> <td>X</td> <td>X</td> <td>X</td> <td>X</td> <td>X</td> <td>X</td> <td>X</td> <td>X</td> <td>X</td> <td>X</td> <td>X</td> <td>X</td> <td>X</td> <td>X</td> <td>X</td> <td>X</td> <td>X</td> <td>X</td> <td>X</td> <td>X</td> </tr> <tr> <td></td> <td></td> <td>8</td> <td>X</td> <td>X</td> <td>X</td> <td>X</td> <td>X</td> <td>X</td> <td>X</td> <td>X</td> <td>X</td> <td>X</td> <td>X</td> <td>X</td> <td>X</td> <td>X</td> <td>X</td> <td>X</td> <td>X</td> <td>X</td> <td>X</td> <td>X</td> <td>X</td> </tr> <tr> <td></td> <td></td> <td>9</td> <td>X</td> <td>X</td> <td>X</td> <td>X</td> <td>X</td> <td>X</td> <td>X</td> <td>X</td> <td>X</td> <td>X</td> <td>X</td> <td>X</td> <td>X</td> <td>X</td> <td>X</td> <td>X</td> <td>X</td> <td>X</td> <td>X</td> <td>X</td> <td>X</td> </tr> <tr> <td></td> <td></td> <td>10</td> <td>X</td> <td>X</td> <td>X</td> <td>X</td> <td>X</td> <td>X</td> <td>X</td> <td>X</td> <td>X</td> <td>X</td> <td>X</td> <td>X</td> <td>X</td> <td>X</td> <td>X</td> <td>X</td> <td>X</td> <td>X</td> <td>X</td> <td>X</td> <td>X</td> </tr> <tr> <td></td> <td></td> <td>11</td> <td>X</td> <td>X</td> <td>X</td> <td>X</td> <td>X</td> <td>X</td> <td>X</td> <td>X</td> <td>X</td> <td>X</td> <td>X</td> <td>X</td> <td>X</td> <td>X</td> <td>X</td> <td>X</td> <td>X</td> <td>X</td> <td>X</td> <td>X</td> <td>X</td> </tr> <tr> <td></td> <td></td> <td>12</td> <td>X</td> <td>X</td> <td>X</td> <td>X</td> <td>X</td> <td>X</td> <td>X</td> <td>X</td> <td>X</td> <td>X</td> <td>X</td> <td>X</td> <td>X</td> <td>X</td> <td>X</td> <td>X</td> <td>X</td> <td>X</td> <td>X</td> <td>X</td> <td>X</td> </tr> </table>	AMMETER VOLTMETER		CONTACTS HANDLE END												OFF		ODD	EVEN											OFF	3	0	1	X	X	X	X	X	X	X	X	X	X	X	X	X	X	X	X	X	X	X	X	X	2		2	X	X	X	X	X	X	X	X	X	X	X	X	X	X	X	X	X	X	X	X	X			3	X	X	X	X	X	X	X	X	X	X	X	X	X	X	X	X	X	X	X	X	X			4	X	X	X	X	X	X	X	X	X	X	X	X	X	X	X	X	X	X	X	X	X			5	X	X	X	X	X	X	X	X	X	X	X	X	X	X	X	X	X	X	X	X	X			6	X	X	X	X	X	X	X	X	X	X	X	X	X	X	X	X	X	X	X	X	X			7	X	X	X	X	X	X	X	X	X	X	X	X	X	X	X	X	X	X	X	X	X			8	X	X	X	X	X	X	X	X	X	X	X	X	X	X	X	X	X	X	X	X	X			9	X	X	X	X	X	X	X	X	X	X	X	X	X	X	X	X	X	X	X	X	X			10	X	X	X	X	X	X	X	X	X	X	X	X	X	X	X	X	X	X	X	X	X			11	X	X	X	X	X	X	X	X	X	X	X	X	X	X	X	X	X	X	X	X	X			12	X	X	X	X	X	X	X	X	X	X	X	X	X	X	X	X	X	X	X	X	X	
AMMETER VOLTMETER		CONTACTS HANDLE END																																																																																																																																																																																																																																																																																																																														
OFF		ODD	EVEN											OFF																																																																																																																																																																																																																																																																																																																		
3	0	1	X	X	X	X	X	X	X	X	X	X	X	X	X	X	X	X	X	X	X	X	X																																																																																																																																																																																																																																																																																																									
2		2	X	X	X	X	X	X	X	X	X	X	X	X	X	X	X	X	X	X	X	X	X																																																																																																																																																																																																																																																																																																									
		3	X	X	X	X	X	X	X	X	X	X	X	X	X	X	X	X	X	X	X	X	X																																																																																																																																																																																																																																																																																																									
		4	X	X	X	X	X	X	X	X	X	X	X	X	X	X	X	X	X	X	X	X	X																																																																																																																																																																																																																																																																																																									
		5	X	X	X	X	X	X	X	X	X	X	X	X	X	X	X	X	X	X	X	X	X																																																																																																																																																																																																																																																																																																									
		6	X	X	X	X	X	X	X	X	X	X	X	X	X	X	X	X	X	X	X	X	X																																																																																																																																																																																																																																																																																																									
		7	X	X	X	X	X	X	X	X	X	X	X	X	X	X	X	X	X	X	X	X	X																																																																																																																																																																																																																																																																																																									
		8	X	X	X	X	X	X	X	X	X	X	X	X	X	X	X	X	X	X	X	X	X																																																																																																																																																																																																																																																																																																									
		9	X	X	X	X	X	X	X	X	X	X	X	X	X	X	X	X	X	X	X	X	X																																																																																																																																																																																																																																																																																																									
		10	X	X	X	X	X	X	X	X	X	X	X	X	X	X	X	X	X	X	X	X	X																																																																																																																																																																																																																																																																																																									
		11	X	X	X	X	X	X	X	X	X	X	X	X	X	X	X	X	X	X	X	X	X																																																																																																																																																																																																																																																																																																									
		12	X	X	X	X	X	X	X	X	X	X	X	X	X	X	X	X	X	X	X	X	X																																																																																																																																																																																																																																																																																																									
16	AMMETER-VOLTMETER TRANSFER SWITCH Three-phase, four wires phase-to-neutral plus three independent current transformer circuits Model No. 10AA015 Knurled handle	<table border="1"> <tr> <td colspan="2">AMMETER VOLTMETER</td> <td colspan="12">CONTACTS HANDLE END</td> </tr> <tr> <td colspan="2">OFF</td> <td>ODD</td> <td colspan="11">EVEN</td> <td>OFF</td> </tr> <tr> <td>3</td> <td>0</td> <td>1</td> <td>X</td> <td>X</td> <td>X</td> <td>X</td> <td>X</td> <td>X</td> <td>X</td> <td>X</td> <td>X</td> <td>X</td> <td>X</td> <td>X</td> <td>X</td> <td>X</td> <td>X</td> <td>X</td> <td>X</td> <td>X</td> <td>X</td> <td>X</td> <td>X</td> </tr> <tr> <td>2</td> <td></td> <td>2</td> <td>X</td> <td>X</td> <td>X</td> <td>X</td> <td>X</td> <td>X</td> <td>X</td> <td>X</td> <td>X</td> <td>X</td> <td>X</td> <td>X</td> <td>X</td> <td>X</td> <td>X</td> <td>X</td> <td>X</td> <td>X</td> <td>X</td> <td>X</td> <td>X</td> </tr> <tr> <td></td> <td></td> <td>3</td> <td>X</td> <td>X</td> <td>X</td> <td>X</td> <td>X</td> <td>X</td> <td>X</td> <td>X</td> <td>X</td> <td>X</td> <td>X</td> <td>X</td> <td>X</td> <td>X</td> <td>X</td> <td>X</td> <td>X</td> <td>X</td> <td>X</td> <td>X</td> <td>X</td> </tr> <tr> <td></td> <td></td> <td>4</td> <td>X</td> <td>X</td> <td>X</td> <td>X</td> <td>X</td> <td>X</td> <td>X</td> <td>X</td> <td>X</td> <td>X</td> <td>X</td> <td>X</td> <td>X</td> <td>X</td> <td>X</td> <td>X</td> <td>X</td> <td>X</td> <td>X</td> <td>X</td> <td>X</td> </tr> <tr> <td></td> <td></td> <td>5</td> <td>X</td> <td>X</td> <td>X</td> <td>X</td> <td>X</td> <td>X</td> <td>X</td> <td>X</td> <td>X</td> <td>X</td> <td>X</td> <td>X</td> <td>X</td> <td>X</td> <td>X</td> <td>X</td> <td>X</td> <td>X</td> <td>X</td> <td>X</td> <td>X</td> </tr> <tr> <td></td> <td></td> <td>6</td> <td>X</td> <td>X</td> <td>X</td> <td>X</td> <td>X</td> <td>X</td> <td>X</td> <td>X</td> <td>X</td> <td>X</td> <td>X</td> <td>X</td> <td>X</td> <td>X</td> <td>X</td> <td>X</td> <td>X</td> <td>X</td> <td>X</td> <td>X</td> <td>X</td> </tr> <tr> <td></td> <td></td> <td>7</td> <td>X</td> <td>X</td> <td>X</td> <td>X</td> <td>X</td> <td>X</td> <td>X</td> <td>X</td> <td>X</td> <td>X</td> <td>X</td> <td>X</td> <td>X</td> <td>X</td> <td>X</td> <td>X</td> <td>X</td> <td>X</td> <td>X</td> <td>X</td> <td>X</td> </tr> <tr> <td></td> <td></td> <td>8</td> <td>X</td> <td>X</td> <td>X</td> <td>X</td> <td>X</td> <td>X</td> <td>X</td> <td>X</td> <td>X</td> <td>X</td> <td>X</td> <td>X</td> <td>X</td> <td>X</td> <td>X</td> <td>X</td> <td>X</td> <td>X</td> <td>X</td> <td>X</td> <td>X</td> </tr> <tr> <td></td> <td></td> <td>9</td> <td>X</td> <td>X</td> <td>X</td> <td>X</td> <td>X</td> <td>X</td> <td>X</td> <td>X</td> <td>X</td> <td>X</td> <td>X</td> <td>X</td> <td>X</td> <td>X</td> <td>X</td> <td>X</td> <td>X</td> <td>X</td> <td>X</td> <td>X</td> <td>X</td> </tr> <tr> <td></td> <td></td> <td>10</td> <td>X</td> <td>X</td> <td>X</td> <td>X</td> <td>X</td> <td>X</td> <td>X</td> <td>X</td> <td>X</td> <td>X</td> <td>X</td> <td>X</td> <td>X</td> <td>X</td> <td>X</td> <td>X</td> <td>X</td> <td>X</td> <td>X</td> <td>X</td> <td>X</td> </tr> <tr> <td></td> <td></td> <td>11</td> <td>X</td> <td>X</td> <td>X</td> <td>X</td> <td>X</td> <td>X</td> <td>X</td> <td>X</td> <td>X</td> <td>X</td> <td>X</td> <td>X</td> <td>X</td> <td>X</td> <td>X</td> <td>X</td> <td>X</td> <td>X</td> <td>X</td> <td>X</td> <td>X</td> </tr> <tr> <td></td> <td></td> <td>12</td> <td>X</td> <td>X</td> <td>X</td> <td>X</td> <td>X</td> <td>X</td> <td>X</td> <td>X</td> <td>X</td> <td>X</td> <td>X</td> <td>X</td> <td>X</td> <td>X</td> <td>X</td> <td>X</td> <td>X</td> <td>X</td> <td>X</td> <td>X</td> <td>X</td> </tr> </table>	AMMETER VOLTMETER		CONTACTS HANDLE END												OFF		ODD	EVEN											OFF	3	0	1	X	X	X	X	X	X	X	X	X	X	X	X	X	X	X	X	X	X	X	X	X	2		2	X	X	X	X	X	X	X	X	X	X	X	X	X	X	X	X	X	X	X	X	X			3	X	X	X	X	X	X	X	X	X	X	X	X	X	X	X	X	X	X	X	X	X			4	X	X	X	X	X	X	X	X	X	X	X	X	X	X	X	X	X	X	X	X	X			5	X	X	X	X	X	X	X	X	X	X	X	X	X	X	X	X	X	X	X	X	X			6	X	X	X	X	X	X	X	X	X	X	X	X	X	X	X	X	X	X	X	X	X			7	X	X	X	X	X	X	X	X	X	X	X	X	X	X	X	X	X	X	X	X	X			8	X	X	X	X	X	X	X	X	X	X	X	X	X	X	X	X	X	X	X	X	X			9	X	X	X	X	X	X	X	X	X	X	X	X	X	X	X	X	X	X	X	X	X			10	X	X	X	X	X	X	X	X	X	X	X	X	X	X	X	X	X	X	X	X	X			11	X	X	X	X	X	X	X	X	X	X	X	X	X	X	X	X	X	X	X	X	X			12	X	X	X	X	X	X	X	X	X	X	X	X	X	X	X	X	X	X	X	X	X	
AMMETER VOLTMETER		CONTACTS HANDLE END																																																																																																																																																																																																																																																																																																																														
OFF		ODD	EVEN											OFF																																																																																																																																																																																																																																																																																																																		
3	0	1	X	X	X	X	X	X	X	X	X	X	X	X	X	X	X	X	X	X	X	X	X																																																																																																																																																																																																																																																																																																									
2		2	X	X	X	X	X	X	X	X	X	X	X	X	X	X	X	X	X	X	X	X	X																																																																																																																																																																																																																																																																																																									
		3	X	X	X	X	X	X	X	X	X	X	X	X	X	X	X	X	X	X	X	X	X																																																																																																																																																																																																																																																																																																									
		4	X	X	X	X	X	X	X	X	X	X	X	X	X	X	X	X	X	X	X	X	X																																																																																																																																																																																																																																																																																																									
		5	X	X	X	X	X	X	X	X	X	X	X	X	X	X	X	X	X	X	X	X	X																																																																																																																																																																																																																																																																																																									
		6	X	X	X	X	X	X	X	X	X	X	X	X	X	X	X	X	X	X	X	X	X																																																																																																																																																																																																																																																																																																									
		7	X	X	X	X	X	X	X	X	X	X	X	X	X	X	X	X	X	X	X	X	X																																																																																																																																																																																																																																																																																																									
		8	X	X	X	X	X	X	X	X	X	X	X	X	X	X	X	X	X	X	X	X	X																																																																																																																																																																																																																																																																																																									
		9	X	X	X	X	X	X	X	X	X	X	X	X	X	X	X	X	X	X	X	X	X																																																																																																																																																																																																																																																																																																									
		10	X	X	X	X	X	X	X	X	X	X	X	X	X	X	X	X	X	X	X	X	X																																																																																																																																																																																																																																																																																																									
		11	X	X	X	X	X	X	X	X	X	X	X	X	X	X	X	X	X	X	X	X	X																																																																																																																																																																																																																																																																																																									
		12	X	X	X	X	X	X	X	X	X	X	X	X	X	X	X	X	X	X	X	X	X																																																																																																																																																																																																																																																																																																									

X In all contact diagrams denotes contacts closed

Contact Diagrams SBM

Fig #	DESCRIPTION	ESCUTCHEON & CONTACT DIAGRAM	WIRING DIAGRAM
17	AMMETER-VOLTMETER TRANSFER SWITCH Three-phase, three wires phase-to-phase plus three current transformers (connect at end of secondary) <i>Model No. 10AA016</i> Knurled handle		
18	WATTMETER TRANSFER SWITCH Two current coils <i>Model No. 10AA018</i> Knurled handle		
19	WATTMETER TRANSFER SWITCH Three current coils <i>Model No. 10AA019</i> Knurled handle		
20	WATTMETER TRANSFER SWITCH Two current and two potential coils <i>Model No. 10AA020</i> Knurled handle		

X In all contact diagrams denotes contacts closed

Contact Diagrams SBM

Fig #	DESCRIPTION	ESCUTCHEON & CONTACT DIAGRAM	WIRING DIAGRAM
21	CIRCUIT-BREAKER CONTROL SWITCH Model No. 10AA100 Pistol-grip handle		
22	CIRCUIT BREAKER CONTROL SWITCH Model No. 10AA101 Pistol-grip handle		
23	CIRCUIT BREAKER CONTROL SWITCH For operating two breakers Model No. 10AA104 Pistol-grip handle		
24	GOVERNOR OR RHEOSTAT MOTOR CONTROL SWITCH Model No. 10AA066 Lever handle		

X In all contact diagrams denotes contacts closed

Contact Diagrams SBM

Fig #	DESCRIPTION	ESCUTCHEON & CONTACT DIAGRAM	Fig #	DESCRIPTION	ESCUTCHEON & CONTACT DIAGRAM
25	CIRCUIT-BREAKER CONTROL SWITCH <i>Model No. 10AA106</i> Pistol-grip handle		29	CIRCUIT-BREAKER CONTROL SWITCH <i>Model No. 10AA110</i> Pistol-grip handle	
26	CIRCUIT-BREAKER CONTROL SWITCH <i>Model No. 10AA107</i> Pistol-grip handle		30	CIRCUIT-BREAKER CONTROL SWITCH <i>Model No. 10AA111</i> Pistol-grip handle	
27	CIRCUIT-BREAKER CONTROL SWITCH <i>Model No. 10AA108</i> Pistol-grip handle		31	CIRCUIT-BREAKER CONTROL SWITCH <i>Model No. 10AA112</i> Pistol-grip handle	
28	CIRCUIT-BREAKER CONTROL SWITCH <i>Model No. 10AA109</i> Pistol-grip handle		32	CIRCUIT-BREAKER CONTROL SWITCH <i>Model No. 10AA113</i> Pistol-grip handle	

X In all contact diagrams denotes contacts closed

Contact Diagrams SBM

Fig #	DESCRIPTION	ESCUTCHEON & CONTACT DIAGRAM	Fig #	DESCRIPTION	ESCUTCHEON & CONTACT DIAGRAM
33	CIRCUIT-BREAKER CONTROL SWITCH <i>Model No. 10AA114</i> Pistol-grip handle	<p>Spring return</p>	37	CIRCUIT-BREAKER CONTROL SWITCH <i>Model No. 10AA118</i> Pistol-grip handle	<p>Spring return</p>
34	CIRCUIT-BREAKER CONTROL SWITCH <i>Model No. 10AA115</i> Pistol-grip handle	<p>Spring return</p>	38	CIRCUIT-BREAKER CONTROL SWITCH <i>Model No. 10AA119</i> Pistol-grip handle	<p>Spring return</p>
35	CIRCUIT-BREAKER CONTROL SWITCH <i>Model No. 10AA116</i> Pistol-grip handle	<p>Spring return</p>	39	CIRCUIT-BREAKER CONTROL SWITCH <i>Model No. 10AA120</i> Pistol-grip handle	<p>Spring return</p>
36	CIRCUIT-BREAKER CONTROL SWITCH <i>Model No. 10AA117</i> Pistol-grip handle	<p>Spring return</p>	40	CIRCUIT-BREAKER CONTROL SWITCH <i>Model No. 10AA121</i> Pistol-grip handle	<p>Spring return</p>

X In all contact diagrams denotes contacts closed

Contact Diagrams SBM

Fig #	DESCRIPTION	ESCUTCHEON & CONTACT DIAGRAM	Fig #	DESCRIPTION	ESCUTCHEON & CONTACT DIAGRAM
41	CIRCUIT-BREAKER CONTROL SWITCH <i>Model No. 10AA122</i> Pistol-grip handle		45	TRIP SWITCH Contacts normally open <i>Model No. 10AA102</i> Pistol-grip handle	
42	CIRCUIT-BREAKER CONTROL SWITCH <i>Model No. 10AA123</i> Pistol-grip handle		46	TRIP SWITCH Contacts normally closed <i>Model No. 10AA103</i> Pistol-grip handle	
43	CIRCUIT-BREAKER CONTROL SWITCH <i>Model No. 10AA124</i> Pistol-grip handle				
44	SWITCH SUBSTITUTE For push-button station <i>Model No. 10AA105</i> Pistol-grip handle				

X In all contact diagrams denotes contacts closed

Contact Diagrams SBM

Fig #	DESCRIPTION	ESCUTCHEON & CONTACT DIAGRAM	WIRING DIAGRAM
47	POWER-FACTOR SWITCH One or two current coils Model No. 10AA021 Knurled handle		
48	POWER-FACTOR SWITCH One current and two potential coils Model No. 10AA022 Knurled handle		
49	POWER-FACTOR OR WATTMETER REVERSING SWITCH Model No. 10AA023 Knurled handle		
50	MOTOR CONTROL SWITCH Model No. 10AA067 Pistol-grip handle		

X In all contact diagrams denotes contacts closed

Contact Diagrams SBM

Fig #	DESCRIPTION	ESCUTCHEON & CONTACT DIAGRAM	WIRING DIAGRAM
51	MOTOR CONTROL SWITCH For split-field motors Model No. 10AA065 Pistol-grip handle		
52	SYNCHRONIZING SWITCH Machine-to-bus with interlocks Model No. 10AA024 Uses removable oval handle, 23WW145*		
53	SYNCHRONIZING SWITCH Running and incoming Model No. 10AA025 Uses one each removable oval handle R = 23WL235* I = 23WR235*		
54	SYNCHRONIZING SWITCH Between machines without potential transformers Model No. 10AA026 Uses removable oval handle, 23WW123*		

X In all contact diagrams denotes contacts closed
 * Removable handles must be ordered separately

Contact Diagrams SBM

Fig #	DESCRIPTION	ESCUTCHEON & CONTACT DIAGRAM	Fig #	DESCRIPTION	ESCUTCHEON & CONTACT DIAGRAM
55	SINGLE OR DOUBLE POLE Single-throw, maintain contact Model No. 10AA027 With spring return Model No. 10AA028 Oval handle		58	SINGLE-POLE Double-throw with off, maintain contact Model No. 10AA039 With spring return Model No. 10AA040 Oval handle	
56	THREE OR FOUR POLE Single-throw, maintain contact Model No. 10AA029 With spring return Model No. 10AA030 Oval handle		59	DOUBLE-THROW Double-throw with off, maintain contact Model No. 10AA041 With spring return Model No. 10AA042 Oval handle	
57	A. FIVE OR SIX POLE Single-throw, maintain contact Model No. 10AA031 With spring return Model No. 10AA032 Oval handle B. SEVEN OR EIGHT-POLE Single-throw, maintained Model No. 10AA033 With spring return Model No. 10AA034 C. NINE OR TEN-POLE Single-throw, maintained Model No. 10AA035 With spring return Model No. 10AA036 D. ELEVEN OR TWELVE-POLE Single-throw, maintained Model No. 10AA037 With spring return Model No. 10AA038		60	A. THREE-POLE Double-throw, with off maintain contact Model No. 10AA068 With spring return Model No. 10AA043 Oval handle B. FOUR-POLE Double-throw with off, maintained Model No. 10AA044 With spring return Model No. 10AA045 C. FIVE-POLE Double-throw with off, maintained Model No. 10AA046 With spring return Model No. 10AA047 D. SIX-POLE Double-throw with off maintained Model No. 10AA048 With spring return Model No. 10AA049	

X In all contact diagrams denotes contacts closed

Contact Diagrams SBM

Fig #	DESCRIPTION	ESCUTCHEON & CONTACT DIAGRAM	Fig #	DESCRIPTION	ESCUTCHEON & CONTACT DIAGRAM
61	SINGLE-POLE Double-throw <i>Model No. 10AA050</i> Oval handle		65	SINGLE-POLE Four-throw <i>Model No. 10AA058</i> Oval handle	
62	DOUBLE-POLE Double-throw <i>Model No. 10AA051</i> Oval handle		66	SINGLE-POLE Five-throw, maintain contact <i>Model No. 10AA059</i> Oval handle	
63	A. THREE-POLE Double-throw <i>Model No. 10AA052</i> Oval handle B. FOUR-POLE Double-throw <i>Model no. 10AA053</i> C. FIVE-POLE Double-throw <i>Model No. 10AA054</i> D. SIX-POLE Double-throw <i>Model No. 10AA055</i> E. SEVEN-POLE Double-throw <i>Model No. 10AA056</i>		67	SINGLE-POLE Six-throw <i>Model No. 10AA060</i> Oval handle	
64	SINGLE-POLE Three-throw, maintain contact <i>Model No. 10AA057</i> Oval handle		68	SINGLE-POLE Seven-throw <i>Model No. 10AA061</i> Oval handle	

X In all contact diagrams denotes contacts closed

Contact Diagrams SBM

Fig #	DESCRIPTION	ESCUTCHEON & CONTACT DIAGRAM																																																																																																																																				
69	<p>SINGLE-POLE Eight-throw</p> <p>Model No. 10AA062 Oval handle</p>	<p>The escutcheon diagram shows a central '0' with positions 1, 2, 3, 4, 5, 6, 7, and 8 arranged around it. The contact diagram is a table with 8 rows (numbered 1-8) and 12 columns (numbered 1-12). The 'CONTACTS HANDLE END' section is divided into 'ODD' and 'EVEN' columns. 'X' marks indicate closed contacts.</p> <table border="1"> <thead> <tr> <th rowspan="2"></th> <th colspan="6">CONTACTS HANDLE END</th> </tr> <tr> <th colspan="2">ODD</th> <th colspan="4">EVEN</th> </tr> <tr> <th></th> <th>1</th> <th>2</th> <th>3</th> <th>4</th> <th>5</th> <th>6</th> </tr> </thead> <tbody> <tr> <td>1</td> <td></td> <td></td> <td></td> <td></td> <td></td> <td></td> </tr> <tr> <td>2</td> <td></td> <td></td> <td></td> <td></td> <td></td> <td></td> </tr> <tr> <td>3</td> <td></td> <td></td> <td></td> <td></td> <td></td> <td></td> </tr> <tr> <td>4</td> <td></td> <td></td> <td></td> <td></td> <td></td> <td></td> </tr> <tr> <td>5</td> <td></td> <td></td> <td></td> <td></td> <td></td> <td></td> </tr> <tr> <td>6</td> <td></td> <td></td> <td></td> <td></td> <td></td> <td></td> </tr> <tr> <td>7</td> <td></td> <td></td> <td></td> <td></td> <td></td> <td></td> </tr> <tr> <td>8</td> <td></td> <td></td> <td></td> <td></td> <td></td> <td></td> </tr> </tbody> </table>		CONTACTS HANDLE END						ODD		EVEN					1	2	3	4	5	6	1							2							3							4							5							6							7							8																																																														
	CONTACTS HANDLE END																																																																																																																																					
	ODD		EVEN																																																																																																																																			
	1	2	3	4	5	6																																																																																																																																
1																																																																																																																																						
2																																																																																																																																						
3																																																																																																																																						
4																																																																																																																																						
5																																																																																																																																						
6																																																																																																																																						
7																																																																																																																																						
8																																																																																																																																						
70	<p>DOUBLE-POLE Four-throw</p> <p>Model No. 10AA063 Oval handle</p>	<p>The escutcheon diagram shows a central '0' with positions 1, 2, 3, and 4 arranged around it. The contact diagram is a table with 8 rows (numbered 1-8) and 12 columns (numbered 1-12). The 'CONTACTS HANDLE END' section is divided into 'ODD' and 'EVEN' columns. 'X' marks indicate closed contacts.</p> <table border="1"> <thead> <tr> <th rowspan="2"></th> <th colspan="6">CONTACTS HANDLE END</th> </tr> <tr> <th colspan="2">ODD</th> <th colspan="4">EVEN</th> </tr> <tr> <th></th> <th>1</th> <th>2</th> <th>3</th> <th>4</th> <th>5</th> <th>6</th> </tr> </thead> <tbody> <tr> <td>1</td> <td></td> <td></td> <td></td> <td></td> <td></td> <td></td> </tr> <tr> <td>2</td> <td></td> <td></td> <td></td> <td></td> <td></td> <td></td> </tr> <tr> <td>3</td> <td></td> <td></td> <td></td> <td></td> <td></td> <td></td> </tr> <tr> <td>4</td> <td></td> <td></td> <td></td> <td></td> <td></td> <td></td> </tr> <tr> <td>5</td> <td></td> <td></td> <td></td> <td></td> <td></td> <td></td> </tr> <tr> <td>6</td> <td></td> <td></td> <td></td> <td></td> <td></td> <td></td> </tr> <tr> <td>7</td> <td></td> <td></td> <td></td> <td></td> <td></td> <td></td> </tr> <tr> <td>8</td> <td></td> <td></td> <td></td> <td></td> <td></td> <td></td> </tr> </tbody> </table>		CONTACTS HANDLE END						ODD		EVEN					1	2	3	4	5	6	1							2							3							4							5							6							7							8																																																														
	CONTACTS HANDLE END																																																																																																																																					
	ODD		EVEN																																																																																																																																			
	1	2	3	4	5	6																																																																																																																																
1																																																																																																																																						
2																																																																																																																																						
3																																																																																																																																						
4																																																																																																																																						
5																																																																																																																																						
6																																																																																																																																						
7																																																																																																																																						
8																																																																																																																																						
71	<p>DOUBLE-POLE Eight-throw</p> <p>Model No. 10AA064 Oval handle</p>	<p>The escutcheon diagram shows a central '0' with positions 1, 2, 3, 4, 5, 6, 7, and 8 arranged around it. The contact diagram is a table with 16 rows (numbered 1-16) and 12 columns (numbered 1-12). The 'CONTACTS HANDLE END' section is divided into 'ODD' and 'EVEN' columns. 'X' marks indicate closed contacts.</p> <table border="1"> <thead> <tr> <th rowspan="2"></th> <th colspan="6">CONTACTS HANDLE END</th> </tr> <tr> <th colspan="2">ODD</th> <th colspan="4">EVEN</th> </tr> <tr> <th></th> <th>1</th> <th>2</th> <th>3</th> <th>4</th> <th>5</th> <th>6</th> </tr> </thead> <tbody> <tr> <td>1</td> <td></td> <td></td> <td></td> <td></td> <td></td> <td></td> </tr> <tr> <td>2</td> <td></td> <td></td> <td></td> <td></td> <td></td> <td></td> </tr> <tr> <td>3</td> <td></td> <td></td> <td></td> <td></td> <td></td> <td></td> </tr> <tr> <td>4</td> <td></td> <td></td> <td></td> <td></td> <td></td> <td></td> </tr> <tr> <td>5</td> <td></td> <td></td> <td></td> <td></td> <td></td> <td></td> </tr> <tr> <td>6</td> <td></td> <td></td> <td></td> <td></td> <td></td> <td></td> </tr> <tr> <td>7</td> <td></td> <td></td> <td></td> <td></td> <td></td> <td></td> </tr> <tr> <td>8</td> <td></td> <td></td> <td></td> <td></td> <td></td> <td></td> </tr> <tr> <td>9</td> <td></td> <td></td> <td></td> <td></td> <td></td> <td></td> </tr> <tr> <td>10</td> <td></td> <td></td> <td></td> <td></td> <td></td> <td></td> </tr> <tr> <td>11</td> <td></td> <td></td> <td></td> <td></td> <td></td> <td></td> </tr> <tr> <td>12</td> <td></td> <td></td> <td></td> <td></td> <td></td> <td></td> </tr> <tr> <td>13</td> <td></td> <td></td> <td></td> <td></td> <td></td> <td></td> </tr> <tr> <td>14</td> <td></td> <td></td> <td></td> <td></td> <td></td> <td></td> </tr> <tr> <td>15</td> <td></td> <td></td> <td></td> <td></td> <td></td> <td></td> </tr> <tr> <td>16</td> <td></td> <td></td> <td></td> <td></td> <td></td> <td></td> </tr> </tbody> </table>		CONTACTS HANDLE END						ODD		EVEN					1	2	3	4	5	6	1							2							3							4							5							6							7							8							9							10							11							12							13							14							15							16						
	CONTACTS HANDLE END																																																																																																																																					
	ODD		EVEN																																																																																																																																			
	1	2	3	4	5	6																																																																																																																																
1																																																																																																																																						
2																																																																																																																																						
3																																																																																																																																						
4																																																																																																																																						
5																																																																																																																																						
6																																																																																																																																						
7																																																																																																																																						
8																																																																																																																																						
9																																																																																																																																						
10																																																																																																																																						
11																																																																																																																																						
12																																																																																																																																						
13																																																																																																																																						
14																																																																																																																																						
15																																																																																																																																						
16																																																																																																																																						

X In all contact diagrams denotes contacts closed

Contact Diagrams SB-1

Fig #	DESCRIPTION	ESCUTCHEON & CONTACT DIAGRAM	WIRING DIAGRAM
72	VOLTMETER SWITCH Double-pole, single-throw Model No. 16SB1CA1 Knurled handle		
73	VOLTMETER SWITCH Double-pole, double-throw Model No. 16SB1CE27 Knurled handle		
74	VOLTMETER SWITCH Phase-to-phase or phase-to-neutral Model No. 16SB1CF11 Knurled handle		<p>3-phase 3-wire</p> <p>3-phase, 4-wire (future alternate connection)</p>
75	VOLTMETER SWITCH Three phase-to-phase, phase-to-neutral Model No. 16SB1CF16 Knurled handle		

X In all contact diagrams denotes contacts closed

Contact Diagrams SB-1

Fig #	DESCRIPTION	ESCUTCHEON & CONTACT DIAGRAM	WIRING DIAGRAM
76	VOLTMETER TRANSFER SWITCH Three-phase, four wires, phase-to-neutral Model No. 16SB1CF22 Knurled handle		
77	VOLTMETER TRANSFER SWITCH Two three-phase, three-wire circuits Model No. 16SB1CF23 Knurled handle		
78	AMMETER TRANSFER SWITCH Three independent circuits Model No. 16SB1CA7 Knurled handle		
79	AMMETER TRANSFER SWITCH Three independent circuits with off Model No. 16SB1CA15 Knurled handle		<p>For three independent circuits, remove jumpers 1C-5C and 5C-9C</p>

X In all contact diagrams denotes contacts closed

Contact Diagrams SB-1

Fig #	DESCRIPTION	ESCUTCHEON & CONTACT DIAGRAM	WIRING DIAGRAM
80	<p>AMMETER TRANSFER SWITCH (Connect at end of secondary)</p> <p><i>Model No. 16SB1CA18</i> Knurled handle</p>		<p>For three independent circuits, remove jumpers 1C-5C and 5C-9C</p>
81	<p>AMMETER TRANSFER SWITCH Three current transformers with off (connect at end of secondary)</p> <p><i>Model No. 16SB1CA19</i> Knurled handle</p>		
82	<p>AMMETER TRANSFER SWITCH Two current transformers with off (connect at end of secondary)</p> <p><i>Model No. 16SB1CA20</i></p>		
83	<p>AMMETER TRANSFER SWITCH Two current transformers (connect at end of secondary)</p> <p><i>Model No. 16SB1CE25</i> Knurled handle</p>		

X In all contact diagrams denotes contacts closed

Contact Diagrams SB-1

Fig #	DESCRIPTION	ESCUTCHEON & CONTACT DIAGRAM	WIRING DIAGRAM
84	<p>AMMETER TRANSFER SWITCH Four independent circuits plus off</p> <p><i>Model No. 16SB1CF17</i> Knurled handle</p>		
85	<p>AMMETER-VOLTMETER TRANSFER SWITCH Three-phase, three wire, phase-to-phase plus three independent current transformer circuits</p> <p><i>Model No. 16SB1CA21</i> Knurled handle</p>		
86	<p>AMMETER-VOLTMETER TRANSFER SWITCH Three-phase, four wire phase-to-neutral plus three independent current transformer circuits</p> <p><i>Model No. 16SB1CA23</i> Knurled handle</p>		
87	<p>AMMETER-VOLTMETER TRANSFER SWITCH Three-phase, three wire phase-to-phase plus three current transformers (connect at end of secondary)</p> <p><i>Model No. 16SB1CA24</i> Knurled handle</p>		

X In all contact diagrams denotes contacts closed

Contact Diagrams SB-1

Fig #	DESCRIPTION	ESCUTCHEON & CONTACT DIAGRAM	WIRING DIAGRAM
88	AMMETER-VOLTMETER TRANSFER SWITCH Three-phase, four wire phase-to-neutral plus three current transformers (connect at end of secondary) <i>Model No. 16SB1CA25</i> Knurled handle		
89	AMMETER TRANSFER SWITCH Six current transformers with off (connect at end of secondary) <i>Model No. 16SB1CA28</i> Knurled handle		
90	AMMETER TRANSFER SWITCH Six independent circuits plus off <i>Model No. 16SB1CA29</i> Knurled handle		
91	CIRCUIT-BREAKER CONTROL SWITCH <i>Model No. 16SB1B1</i> Pistol-grip handle		

X In all contact diagrams denotes contacts closed

Contact Diagrams SB-1

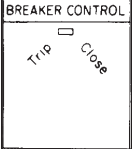
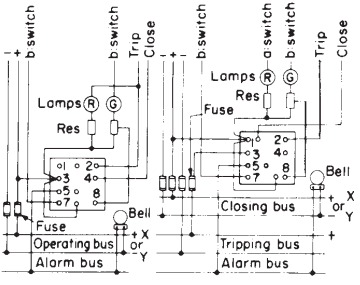
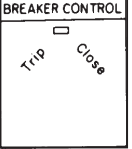
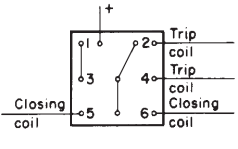
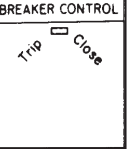
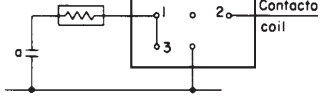
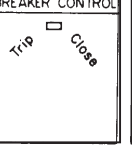
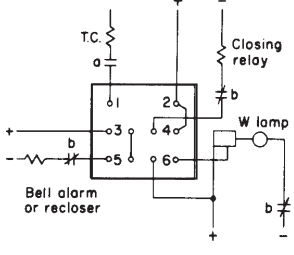
Fig #	DESCRIPTION	ESCUTCHEON & CONTACT DIAGRAM	WIRING DIAGRAM																																											
92	CIRCUIT-BREAKER CONTROL SWITCH Model No. 16SB1B2 Pistol-grip handle	 <table border="1" data-bbox="722 415 950 598"> <thead> <tr> <th rowspan="2">CONTACTS HANDLE END</th> <th colspan="3">Positions</th> </tr> <tr> <th>Close</th> <th>Normal after close</th> <th>Normal after trip</th> <th>Trip</th> </tr> </thead> <tbody> <tr> <td>1</td> <td>X</td> <td></td> <td></td> <td></td> </tr> <tr> <td>2</td> <td></td> <td></td> <td></td> <td>X</td> </tr> <tr> <td>3</td> <td>X</td> <td></td> <td></td> <td>X</td> </tr> <tr> <td>4</td> <td>X</td> <td></td> <td></td> <td></td> </tr> <tr> <td>5</td> <td></td> <td>X</td> <td>X</td> <td></td> </tr> <tr> <td>7</td> <td>X</td> <td>X</td> <td></td> <td></td> </tr> <tr> <td>8</td> <td>X</td> <td>X</td> <td></td> <td></td> </tr> </tbody> </table> <p style="text-align: center;">Spring return</p>	CONTACTS HANDLE END	Positions			Close	Normal after close	Normal after trip	Trip	1	X				2				X	3	X			X	4	X				5		X	X		7	X	X			8	X	X			
CONTACTS HANDLE END	Positions																																													
	Close	Normal after close	Normal after trip	Trip																																										
1	X																																													
2				X																																										
3	X			X																																										
4	X																																													
5		X	X																																											
7	X	X																																												
8	X	X																																												
93	CIRCUIT-BREAKER CONTROL SWITCH For operating two breakers Model No. 16SB1B6 Pistol-grip handle	 <table border="1" data-bbox="722 741 950 882"> <thead> <tr> <th rowspan="2">CONTACTS HANDLE END</th> <th colspan="3">Positions</th> </tr> <tr> <th>Close</th> <th>Normal</th> <th>Trip</th> </tr> </thead> <tbody> <tr> <td>1</td> <td>X</td> <td></td> <td>X</td> </tr> <tr> <td>2</td> <td></td> <td></td> <td>X</td> </tr> <tr> <td>3</td> <td>X</td> <td></td> <td>X</td> </tr> <tr> <td>4</td> <td></td> <td></td> <td>X</td> </tr> <tr> <td>5</td> <td>X</td> <td></td> <td></td> </tr> <tr> <td>6</td> <td>X</td> <td></td> <td></td> </tr> </tbody> </table> <p style="text-align: center;">Spring return</p>	CONTACTS HANDLE END	Positions			Close	Normal	Trip	1	X		X	2			X	3	X		X	4			X	5	X			6	X															
CONTACTS HANDLE END	Positions																																													
	Close	Normal	Trip																																											
1	X		X																																											
2			X																																											
3	X		X																																											
4			X																																											
5	X																																													
6	X																																													
94	CIRCUIT-BREAKER CONTROL SWITCH Substitute for push button station Model No. 16SB1B7 Pistol-grip handle	 <table border="1" data-bbox="722 1098 950 1218"> <thead> <tr> <th rowspan="2">CONTACTS HANDLE END</th> <th colspan="3">Positions</th> </tr> <tr> <th>Close</th> <th>Normal</th> <th>Trip</th> </tr> </thead> <tbody> <tr> <td>1</td> <td>X</td> <td>X</td> <td></td> </tr> <tr> <td>2</td> <td>X</td> <td>X</td> <td></td> </tr> <tr> <td>3</td> <td>X</td> <td></td> <td></td> </tr> </tbody> </table> <p style="text-align: center;">Spring return</p>	CONTACTS HANDLE END	Positions			Close	Normal	Trip	1	X	X		2	X	X		3	X																											
CONTACTS HANDLE END	Positions																																													
	Close	Normal	Trip																																											
1	X	X																																												
2	X	X																																												
3	X																																													
95	CIRCUIT-BREAKER CONTROL SWITCH Model No. 16SB1B9 Pistol-grip handle	 <table border="1" data-bbox="722 1455 950 1596"> <thead> <tr> <th rowspan="2">CONTACTS HANDLE END</th> <th colspan="3">Positions</th> </tr> <tr> <th>Close</th> <th>Normal after close</th> <th>Normal after trip</th> <th>Trip</th> </tr> </thead> <tbody> <tr> <td>1</td> <td></td> <td></td> <td></td> <td>X</td> </tr> <tr> <td>2</td> <td></td> <td></td> <td></td> <td>X</td> </tr> <tr> <td>3</td> <td></td> <td>X</td> <td>X</td> <td></td> </tr> <tr> <td>4</td> <td>X</td> <td></td> <td></td> <td></td> </tr> <tr> <td>5</td> <td>X</td> <td>X</td> <td></td> <td></td> </tr> <tr> <td>6</td> <td>X</td> <td>X</td> <td></td> <td></td> </tr> </tbody> </table> <p style="text-align: center;">Spring return</p>	CONTACTS HANDLE END	Positions			Close	Normal after close	Normal after trip	Trip	1				X	2				X	3		X	X		4	X				5	X	X			6	X	X								
CONTACTS HANDLE END	Positions																																													
	Close	Normal after close	Normal after trip	Trip																																										
1				X																																										
2				X																																										
3		X	X																																											
4	X																																													
5	X	X																																												
6	X	X																																												

X In all contact diagrams denotes contacts closed

Contact Diagrams SB-1

Fig #	DESCRIPTION	ESCUTCHEON & CONTACT DIAGRAM	Fig #	DESCRIPTION	ESCUTCHEON & CONTACT DIAGRAM
96	CIRCUIT-BREAKER TRIP SWITCH Contacts normally open <i>Model No. 16SB1B3</i> Pistol-grip handle		100	CIRCUIT-BREAKER CONTROL SWITCH <i>Model No. 16SB1B14</i> Pistol-grip handle	
97	CIRCUIT-BREAKER TRIP SWITCH Contacts normally closed <i>Model No. 16SB1B4</i> Pistol-grip handle		101	CIRCUIT-BREAKER CONTROL SWITCH <i>Model No. 16SB1B15</i> Pistol-grip handle	
98	CIRCUIT-BREAKER CONTROL SWITCH <i>Model No. 16SB1B10</i> Pistol-grip handle		102	CIRCUIT-BREAKER CONTROL SWITCH <i>Model No. 16SB1B16</i> Pistol-grip handle	
99	CIRCUIT-BREAKER CONTROL SWITCH <i>Model No. 16SB1B11</i> Pistol-grip handle		103	CIRCUIT-BREAKER CONTROL SWITCH <i>Model No. 16SB1B17</i> Pistol-grip handle	

X In all contact diagrams denotes contacts closed

Contact Diagrams SB-1

Fig #	DESCRIPTION	ESCUTCHEON & CONTACT DIAGRAM	Fig #	DESCRIPTION	ESCUTCHEON & CONTACT DIAGRAM
104	CIRCUIT-BREAKER CONTROL SWITCH <i>Model No. 16SB1B18</i> Pistol-grip handle	<p>Spring return</p>	108	CIRCUIT-BREAKER CONTROL SWITCH <i>Model No. 16SB1B22</i> Pistol-grip handle	<p>Spring return</p>
105	CIRCUIT-BREAKER CONTROL SWITCH <i>Model No. 16SB1B19</i> Pistol-grip handle	<p>Spring return</p>	109	CIRCUIT-BREAKER CONTROL SWITCH <i>Model No. 16SB1B23</i> Pistol-grip handle	<p>Spring return</p>
106	CIRCUIT-BREAKER CONTROL SWITCH <i>Model No. 16SB1B20</i> Pistol-grip handle	<p>Spring return</p>	110	CIRCUIT-BREAKER CONTROL SWITCH <i>Model No. 16SB1B23</i> Pistol-grip handle	<p>Spring return</p>
107	CIRCUIT-BREAKER CONTROL SWITCH <i>Model No. 16SB1B21</i> Pistol-grip handle	<p>Spring return</p>	111	CIRCUIT-BREAKER CONTROL SWITCH <i>Model No. 16SB1B25</i> Pistol-grip handle	<p>Spring return</p>

X In all contact diagrams denotes contacts closed

Contact Diagrams SB-1

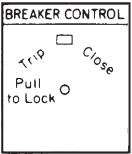
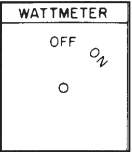
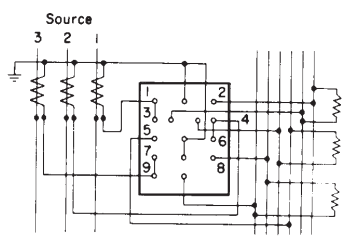
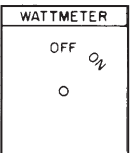
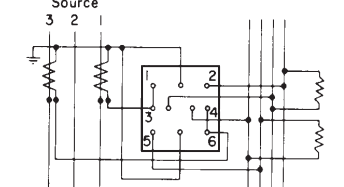
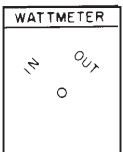
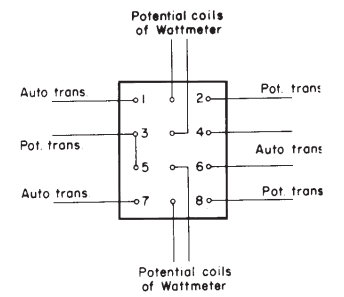
Fig #	DESCRIPTION	ESCUTCHEON & CONTACT DIAGRAM	WIRING DIAGRAM																																																						
112	CIRCUIT-BREAKER CONTROL SWITCH <i>Model No. 16SB1B26</i> Pistol-grip handle	 <table border="1" data-bbox="734 373 961 655"> <thead> <tr> <th colspan="2">CONTACTS</th> <th colspan="4">HANDLE</th> </tr> <tr> <th colspan="2">HANDLE</th> <th colspan="4">END</th> </tr> <tr> <th>ODD</th> <th>EVEN</th> <th>Close</th> <th>Open after close</th> <th>Normal after trip</th> <th>Tripping Lock</th> </tr> </thead> <tbody> <tr><td>1</td><td>2</td><td>X</td><td></td><td></td><td></td></tr> <tr><td>3</td><td>4</td><td>X</td><td></td><td></td><td></td></tr> <tr><td>5</td><td>6</td><td>X</td><td>X</td><td>X</td><td>X</td></tr> <tr><td>7</td><td>8</td><td>X</td><td>X</td><td>X</td><td>X</td></tr> <tr><td>9</td><td>10</td><td>X</td><td>X</td><td>X</td><td>X</td></tr> <tr><td>11</td><td>12</td><td>X</td><td>X</td><td>X</td><td>X</td></tr> </tbody> </table> <p style="text-align: center;">Spring return</p>	CONTACTS		HANDLE				HANDLE		END				ODD	EVEN	Close	Open after close	Normal after trip	Tripping Lock	1	2	X				3	4	X				5	6	X	X	X	X	7	8	X	X	X	X	9	10	X	X	X	X	11	12	X	X	X	X	
CONTACTS		HANDLE																																																							
HANDLE		END																																																							
ODD	EVEN	Close	Open after close	Normal after trip	Tripping Lock																																																				
1	2	X																																																							
3	4	X																																																							
5	6	X	X	X	X																																																				
7	8	X	X	X	X																																																				
9	10	X	X	X	X																																																				
11	12	X	X	X	X																																																				
113	WATTMETER TRANSFER SWITCH Three current coils <i>Model No. 16SB1CF13</i> Fixed knurled handle <i>Model No. 16SB1CF8</i> Uses removable oval handle, 16SB1CC6*	 <table border="1" data-bbox="734 714 961 949"> <thead> <tr> <th colspan="2">CONTACTS</th> <th colspan="4">HANDLE</th> </tr> <tr> <th colspan="2">HANDLE</th> <th colspan="4">END</th> </tr> <tr> <th>ODD</th> <th>EVEN</th> <th>ON</th> <th>* OFF</th> <th></th> <th></th> </tr> </thead> <tbody> <tr><td>1</td><td>2</td><td>X</td><td>X</td><td>X</td><td>X</td></tr> <tr><td>3</td><td>4</td><td>X</td><td>X</td><td>X</td><td>X</td></tr> <tr><td>5</td><td>6</td><td>X</td><td>X</td><td>X</td><td>X</td></tr> <tr><td>7</td><td>8</td><td>X</td><td>X</td><td>X</td><td>X</td></tr> <tr><td>9</td><td>10</td><td>X</td><td>X</td><td>X</td><td>X</td></tr> </tbody> </table>	CONTACTS		HANDLE				HANDLE		END				ODD	EVEN	ON	* OFF			1	2	X	X	X	X	3	4	X	X	X	X	5	6	X	X	X	X	7	8	X	X	X	X	9	10	X	X	X	X							
CONTACTS		HANDLE																																																							
HANDLE		END																																																							
ODD	EVEN	ON	* OFF																																																						
1	2	X	X	X	X																																																				
3	4	X	X	X	X																																																				
5	6	X	X	X	X																																																				
7	8	X	X	X	X																																																				
9	10	X	X	X	X																																																				
114	WATTMETER TRANSFER SWITCH Two current coils <i>Model No. 16SB1CB12</i> Fixed knurled handle <i>Model No. 16SB1CF7</i> Uses removable oval handle, 16SB1CC6*	 <table border="1" data-bbox="734 1066 961 1251"> <thead> <tr> <th colspan="2">CONTACTS</th> <th colspan="4">HANDLE</th> </tr> <tr> <th colspan="2">HANDLE</th> <th colspan="4">END</th> </tr> <tr> <th>ODD</th> <th>EVEN</th> <th>ON</th> <th>* OFF</th> <th></th> <th></th> </tr> </thead> <tbody> <tr><td>1</td><td>2</td><td>X</td><td>X</td><td>X</td><td>X</td></tr> <tr><td>3</td><td>4</td><td>X</td><td>X</td><td>X</td><td>X</td></tr> <tr><td>5</td><td>6</td><td>X</td><td>X</td><td>X</td><td>X</td></tr> </tbody> </table>	CONTACTS		HANDLE				HANDLE		END				ODD	EVEN	ON	* OFF			1	2	X	X	X	X	3	4	X	X	X	X	5	6	X	X	X	X																			
CONTACTS		HANDLE																																																							
HANDLE		END																																																							
ODD	EVEN	ON	* OFF																																																						
1	2	X	X	X	X																																																				
3	4	X	X	X	X																																																				
5	6	X	X	X	X																																																				
139	POWER-FACTOR OR WATTMETER REVERSING SWITCH <i>Model No. 16SB1CA10</i> Two position Knurled handle <i>Model No. 16SB1CB4</i> Three position Engraved W - off - RVA	 <table border="1" data-bbox="708 1411 935 1621"> <thead> <tr> <th colspan="2">CONTACTS</th> <th colspan="4">HANDLE</th> </tr> <tr> <th colspan="2">HANDLE</th> <th colspan="4">END</th> </tr> <tr> <th>ODD</th> <th>EVEN</th> <th>OUT (BLANK)</th> <th>IN</th> <th></th> <th></th> </tr> </thead> <tbody> <tr><td>1</td><td>2</td><td>X</td><td></td><td></td><td></td></tr> <tr><td>3</td><td>4</td><td>X</td><td></td><td></td><td></td></tr> <tr><td>5</td><td>6</td><td>X</td><td>X</td><td>X</td><td>X</td></tr> <tr><td>7</td><td>8</td><td>X</td><td>X</td><td>X</td><td>X</td></tr> </tbody> </table>	CONTACTS		HANDLE				HANDLE		END				ODD	EVEN	OUT (BLANK)	IN			1	2	X				3	4	X				5	6	X	X	X	X	7	8	X	X	X	X													
CONTACTS		HANDLE																																																							
HANDLE		END																																																							
ODD	EVEN	OUT (BLANK)	IN																																																						
1	2	X																																																							
3	4	X																																																							
5	6	X	X	X	X																																																				
7	8	X	X	X	X																																																				

X In all contact diagrams denotes contacts closed
 * Removable handles must be ordered separately

Contact Diagrams SB-1

Fig #	DESCRIPTION	ESCUTCHEON & CONTACT DIAGRAM	WIRING DIAGRAM
116	WATTMETER TRANSFER SWITCH Two current and two potential coils <i>Model No. 16SB1CB14</i> Knurled handle		
117	POWER-FACTOR SWITCH One current and two potential coils <i>Model No. 16SB1CA26</i> Fixed knurled handle <i>Model No. 16SB1CF6</i> Uses removable oval handle 16SB1CC5 *		
118	POWER-FACTOR SWITCH One or two current coils <i>Model No. 16SB1CA22</i> Knurled handle <i>Model No. 16SB1CA8</i> Uses removable oval handle 16SB1CC5 *		
119	SYNCHRONIZING SWITCH Machine-to-bus with interlocks <i>Model No. 16SB1CF9</i> Uses removable oval handle 16SB1CC7 *		

X In all contact diagrams denotes contacts closed
 * Removable handles must be ordered separately

Contact Diagrams SB-1

Fig #	DESCRIPTION	ESCUTCHEON & CONTACT DIAGRAM	WIRING DIAGRAM
120	<p>SYNCHRONIZING SWITCH Between machines without potential transformers</p> <p>Model No. 16SB1CB15 Uses one each removable oval handles</p> <p>R = 16SB1CC8* I = 16SB1CC7*</p>		
121	<p>SYNCHRONIZING SWITCH Between machines with interlocks</p> <p>Model No. 16SB1CB5 Uses one each removable oval handles</p> <p>R = 16SB1CC8* I = 16SB1CC7*</p>		
122	<p>GOVERNOR OR RHEOSTAT MOTOR CONTROL SWITCH Split-field motors are standard for most applications</p> <p>Model No. 16SB1A1 Radial handle</p>		
123	<p>MOTOR CONTROL SWITCH</p> <p>Model No. 16SB1CG44 Pistol-grip handle</p>		

X In all contact diagrams denotes contacts closed
* Removable handles must be ordered separately

Contact Diagrams SB-1

Fig #	DESCRIPTION	ESCUTCHEON & CONTACT DIAGRAM
124	<p>MOTOR CONTROL SWITCH For split-field motors</p> <p><i>Model No. 16SB1AA1</i> Pistol-grip handle</p>	
125	<p>TEMPERATURE-METER TRANSFER SWITCH Transfers two wires to five coils and test</p> <p>Palladium contacts</p> <p><i>Model No. 16SB1CE33</i> Knurled handle</p>	
126	<p>TEMPERATURE-METER TRANSFER SWITCH Transfers two wires to three coils and test</p> <p>Palladium contacts</p> <p><i>Model No. 16SB1CE28</i> Knurled handle</p>	
127	<p>TEMPERATURE-METER TRANSFER SWITCH Transfers three wires to three coils and test</p> <p>Palladium contacts</p> <p><i>Model No. 16SB1CE29</i> Knurled handle</p>	

X In all contact diagrams denotes contacts closed

Contact Diagrams SB-1

Fig #	DESCRIPTION	ESCUTCHEON & CONTACT DIAGRAM
145	<p>TEMPERATURE-METER TRANSFER SWITCH Transfers two wires to four coils and test Palladium contacts</p> <p><i>Model No. 16SB1CE52</i> Uses removable oval handle, 16SB1CC19*</p> <p><i>Model No. 16SB1CE61</i> Fixed knurled handle</p>	
146	<p>TEMPERATURE-METER TRANSFER SWITCH Transfers three wires to three coils with test and off Palladium contacts</p> <p><i>Model No. 16SB1CE55</i> Uses removable oval handle, 16SB1CC19*</p> <p><i>Model No. 16SB1CE63</i> Fixed knurled handle</p>	
147	<p>TEMPERATURE-METER TRANSFER SWITCH Transfers two wires to three coils with test and off Palladium contacts</p> <p><i>Model No. 16SB1CE57</i> Uses removable oval handle, 16SB1CC19*</p> <p><i>Model No. 16SB1CE62</i> Fixed knurled handle</p>	
148	<p>TEMPERATURE-METER TRANSFER SWITCH Transfers three wires to five coils and test Palladium contacts</p> <p><i>Model No. 16SB1CE66</i> Knurled handle</p>	

X In all contact diagrams denotes contacts closed
* Removable handles must be ordered separately

Contact Diagrams SB-1

Fig # DESCRIPTION ESCUTCHEON & CONTACT DIAGRAM

132 **TEMPERATURE-METER TRANSFER SWITCH**
 Transfers two wires to six coils and test
 Palladium contacts
Model No. 16SB1CE67
 Knurled handle

Fig # DESCRIPTION ESCUTCHEON & CONTACT DIAGRAM Fig # DESCRIPTION ESCUTCHEON & CONTACT DIAGRAM

133 **SINGLE OR DOUBLE-POLE**
 Single-throw maintain contact
Model No. 16SB1CG1
 With spring return
Model No. 16SB1CG2
 Oval handle

136 **SINGLE-POLE**
 Double-throw with off maintain contact
Model No. 16SB1CG13
 With spring return
Model No. 16SB1CG14
 Oval handle

134 **THREE OR FOUR-POLE**
 Single-throw maintain contact
Model No. 16SB1CG3
 With spring return
Model No. 16SB1CG4
 Oval handle

137 **DOUBLE-POLE**
 Double-throw with off maintain contact
Model No. 16SB1CG15
 With spring return
Model No. 16SB1CG16
 Oval handle

135 **A. FIVE OR SIX-POLE**
 Single-throw, maintained
Model No. 16SB1CG5
 With spring return
Model No. 16SB1CG6
 Oval handle
B. SEVEN OR EIGHT-POLE
 Single-throw, maintained
Model No. 16SB1CG7
 With spring return
Model No. 16SB1CG8
C. NINE OR TEN-POLE
 Single-throw, maintained
Model No. 16SB1CG9
 With spring return
Model 16SB1CG10
D. ELEVEN OR TWELVE-POLE
 One throw, maintained
Model No. 16SB1CG11
 With spring return
Model No. 16SB1CG12

138 **A. THREE-POLE**
 Double-throw with off, maintain
Model No. 16SB1CG17
 With spring return
Model No. 16SB1CG18
 Oval handle
B. 4P-dt
 With off, maintain
Model 16SB1CG19
 With spring return
Model 16SB1CG20
C. 5P-dt
 With off, maintain
Model No. 16SB1CG21
 With spring return
Model No. 16SB1CG22
D. 6P-dt
 With off, maintain
Model No. 16SB1CG23
 With spring return
Model No. 16SB1CG24

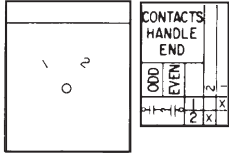
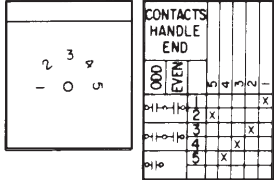
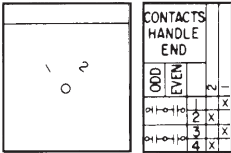
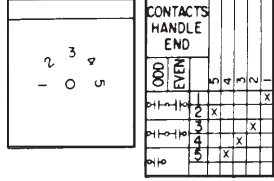
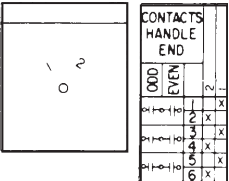
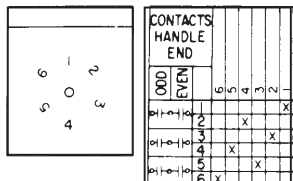
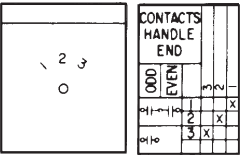
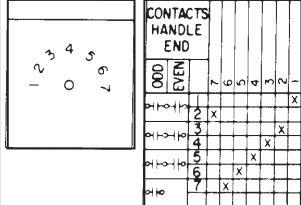

X In all contact diagrams denotes contacts closed

Contact Diagrams SB-1

Fig #	DESCRIPTION	ESCUTCHEON & CONTACT DIAGRAM	Fig #	DESCRIPTION	ESCUTCHEON & CONTACT DIAGRAM
139	SINGLE-POLE Double-throw <i>Model No. 16SB1CG25</i> Oval handle		143	SINGLE-POLE Four-throw <i>Model No. 16SB1CG33</i> Oval handle	
140	DOUBLE-POLE Double-throw <i>Model No. 16SB1CG26</i> Oval handle		144	SINGLE-POLE Five-throw <i>Model No. 16SB1CG34</i> Oval handle	
141	A. THREE-POLE Double-throw <i>Model No. 16SB1CG27</i> Oval handle B. 4P-dt <i>Model No. 16SB1CG28</i> C. 5P-dt <i>Model No. 16SB1CG29</i> D. 6P-dt <i>Model No. 16SB1CG30</i> E. 7P-dt <i>Model No. 16SB1CG31</i>		145	SINGLE-POLE Six-throw <i>Model No. 16SB1CG35</i> Oval handle	
142	SINGLE-POLE Triple-throw <i>Model No. 16SB1CG32</i> Oval handle		146	SINGLE-POLE Seven-throw <i>Model No. 16SB1CG36</i> Oval handle	

X In all contact diagrams denotes contacts closed

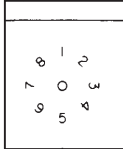
Contact Diagrams SB-1

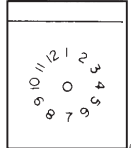
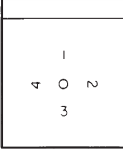
Fig #	DESCRIPTION	ESCUTCHEON & CONTACT DIAGRAM																																																																																																																																																																																						
147	SINGLE-POLE Eight-throw <i>Model No. 16SB1CG37</i> Oval handle	 <table border="1" data-bbox="868 420 1079 630"> <thead> <tr> <th colspan="2">CONTACTS</th> <th colspan="8">HANDLE</th> </tr> <tr> <th colspan="2">END</th> <th>1</th><th>2</th><th>3</th><th>4</th><th>5</th><th>6</th><th>7</th><th>8</th> </tr> <tr> <th>ODD</th> <th>EVEN</th> <th></th><th></th><th></th><th></th><th></th><th></th><th></th><th></th> </tr> </thead> <tbody> <tr> <td>1-1</td> <td>2</td> <td></td><td></td><td></td><td></td><td></td><td></td><td></td><td>X</td> </tr> <tr> <td>1-1</td> <td>3</td> <td></td><td></td><td></td><td></td><td></td><td></td><td>X</td><td></td> </tr> <tr> <td>1-1</td> <td>4</td> <td></td><td>X</td><td></td><td></td><td></td><td>X</td><td></td><td></td> </tr> <tr> <td>1-1</td> <td>5</td> <td></td><td></td><td></td><td></td><td>X</td><td></td><td></td><td></td> </tr> <tr> <td>1-1</td> <td>6</td> <td>X</td><td></td><td></td><td></td><td></td><td></td><td></td><td></td> </tr> <tr> <td>1-1</td> <td>8</td> <td>X</td><td></td><td></td><td>X</td><td></td><td></td><td></td><td></td> </tr> </tbody> </table>	CONTACTS		HANDLE								END		1	2	3	4	5	6	7	8	ODD	EVEN									1-1	2								X	1-1	3							X		1-1	4		X				X			1-1	5					X				1-1	6	X								1-1	8	X			X																																																																																																
CONTACTS		HANDLE																																																																																																																																																																																						
END		1	2	3	4	5	6	7	8																																																																																																																																																																															
ODD	EVEN																																																																																																																																																																																							
1-1	2								X																																																																																																																																																																															
1-1	3							X																																																																																																																																																																																
1-1	4		X				X																																																																																																																																																																																	
1-1	5					X																																																																																																																																																																																		
1-1	6	X																																																																																																																																																																																						
1-1	8	X			X																																																																																																																																																																																			
148	SINGLE-POLE Ten-throw <i>Model No. 16SB1CG38</i> Oval handle	 <table border="1" data-bbox="868 745 1096 976"> <thead> <tr> <th colspan="2">CONTACTS</th> <th colspan="10">HANDLE</th> </tr> <tr> <th colspan="2">END</th> <th>1</th><th>2</th><th>3</th><th>4</th><th>5</th><th>6</th><th>7</th><th>8</th><th>9</th><th>10</th> </tr> <tr> <th>ODD</th> <th>EVEN</th> <th></th><th></th><th></th><th></th><th></th><th></th><th></th><th></th><th></th><th></th> </tr> </thead> <tbody> <tr> <td>1-1</td> <td>2</td> <td></td><td></td><td></td><td></td><td></td><td></td><td></td><td></td><td></td><td>X</td> </tr> <tr> <td>1-1</td> <td>3</td> <td></td><td></td><td></td><td></td><td></td><td></td><td></td><td></td><td>X</td><td></td> </tr> <tr> <td>1-1</td> <td>4</td> <td></td><td></td><td>X</td><td></td><td></td><td></td><td></td><td>X</td><td></td><td></td> </tr> <tr> <td>1-1</td> <td>5</td> <td></td><td></td><td></td><td></td><td></td><td>X</td><td></td><td></td><td></td><td></td> </tr> <tr> <td>1-1</td> <td>6</td> <td>X</td><td></td><td></td><td></td><td></td><td></td><td></td><td></td><td></td><td></td> </tr> <tr> <td>1-1</td> <td>8</td> <td>X</td><td></td><td></td><td></td><td>X</td><td></td><td></td><td></td><td></td><td></td> </tr> <tr> <td>1-1</td> <td>9</td> <td></td><td></td><td></td><td></td><td></td><td></td><td>X</td><td></td><td></td><td></td> </tr> <tr> <td>1-1</td> <td>10</td> <td>X</td><td></td><td></td><td></td><td></td><td></td><td></td><td>X</td><td></td><td></td> </tr> </tbody> </table>	CONTACTS		HANDLE										END		1	2	3	4	5	6	7	8	9	10	ODD	EVEN											1-1	2										X	1-1	3									X		1-1	4			X					X			1-1	5						X					1-1	6	X										1-1	8	X				X						1-1	9							X				1-1	10	X							X																																																				
CONTACTS		HANDLE																																																																																																																																																																																						
END		1	2	3	4	5	6	7	8	9	10																																																																																																																																																																													
ODD	EVEN																																																																																																																																																																																							
1-1	2										X																																																																																																																																																																													
1-1	3									X																																																																																																																																																																														
1-1	4			X					X																																																																																																																																																																															
1-1	5						X																																																																																																																																																																																	
1-1	6	X																																																																																																																																																																																						
1-1	8	X				X																																																																																																																																																																																		
1-1	9							X																																																																																																																																																																																
1-1	10	X							X																																																																																																																																																																															
149	SINGLE-POLE Twelve-throw <i>Model No. 16SB1CG39</i> Oval handle	 <table border="1" data-bbox="868 1071 1096 1333"> <thead> <tr> <th colspan="2">CONTACTS</th> <th colspan="12">HANDLE</th> </tr> <tr> <th colspan="2">END</th> <th>1</th><th>2</th><th>3</th><th>4</th><th>5</th><th>6</th><th>7</th><th>8</th><th>9</th><th>10</th><th>11</th><th>12</th> </tr> <tr> <th>ODD</th> <th>EVEN</th> <th></th><th></th><th></th><th></th><th></th><th></th><th></th><th></th><th></th><th></th><th></th><th></th> </tr> </thead> <tbody> <tr> <td>1-1</td> <td>2</td> <td></td><td></td><td></td><td></td><td></td><td></td><td></td><td></td><td></td><td></td><td></td><td>X</td> </tr> <tr> <td>1-1</td> <td>3</td> <td></td><td></td><td></td><td></td><td></td><td></td><td></td><td></td><td></td><td></td><td>X</td><td></td> </tr> <tr> <td>1-1</td> <td>4</td> <td></td><td></td><td></td><td>X</td><td></td><td></td><td></td><td></td><td></td><td></td><td>X</td><td></td> </tr> <tr> <td>1-1</td> <td>5</td> <td></td><td></td><td></td><td></td><td></td><td></td><td>X</td><td></td><td></td><td></td><td></td><td></td> </tr> <tr> <td>1-1</td> <td>6</td> <td>X</td><td></td><td></td><td></td><td></td><td></td><td></td><td></td><td></td><td></td><td></td><td></td> </tr> <tr> <td>1-1</td> <td>8</td> <td>X</td><td></td><td></td><td></td><td>X</td><td></td><td></td><td></td><td></td><td></td><td></td><td></td> </tr> <tr> <td>1-1</td> <td>9</td> <td></td><td></td><td></td><td></td><td></td><td></td><td></td><td>X</td><td></td><td></td><td></td><td></td> </tr> <tr> <td>1-1</td> <td>10</td> <td>X</td><td></td><td></td><td></td><td></td><td></td><td></td><td></td><td>X</td><td></td><td></td><td></td> </tr> <tr> <td>1-1</td> <td>11</td> <td></td><td></td><td></td><td></td><td></td><td></td><td></td><td></td><td></td><td>X</td><td></td><td></td> </tr> <tr> <td>1-1</td> <td>12</td> <td>X</td><td></td><td></td><td></td><td></td><td></td><td></td><td></td><td></td><td></td><td>X</td><td></td> </tr> </tbody> </table>	CONTACTS		HANDLE												END		1	2	3	4	5	6	7	8	9	10	11	12	ODD	EVEN													1-1	2												X	1-1	3											X		1-1	4				X							X		1-1	5							X						1-1	6	X												1-1	8	X				X								1-1	9								X					1-1	10	X								X				1-1	11										X			1-1	12	X										X	
CONTACTS		HANDLE																																																																																																																																																																																						
END		1	2	3	4	5	6	7	8	9	10	11	12																																																																																																																																																																											
ODD	EVEN																																																																																																																																																																																							
1-1	2												X																																																																																																																																																																											
1-1	3											X																																																																																																																																																																												
1-1	4				X							X																																																																																																																																																																												
1-1	5							X																																																																																																																																																																																
1-1	6	X																																																																																																																																																																																						
1-1	8	X				X																																																																																																																																																																																		
1-1	9								X																																																																																																																																																																															
1-1	10	X								X																																																																																																																																																																														
1-1	11										X																																																																																																																																																																													
1-1	12	X										X																																																																																																																																																																												
150	DOUBLE-POLE Four-throw <i>Model No. 16SB1CG40</i> Oval handle	 <table border="1" data-bbox="868 1449 1096 1659"> <thead> <tr> <th colspan="2">CONTACTS</th> <th colspan="4">HANDLE</th> </tr> <tr> <th colspan="2">END</th> <th>1</th><th>2</th><th>3</th><th>4</th> </tr> <tr> <th>ODD</th> <th>EVEN</th> <th></th><th></th><th></th><th></th> </tr> </thead> <tbody> <tr> <td>1-1</td> <td>2</td> <td></td><td>X</td><td></td><td>X</td> </tr> <tr> <td>1-1</td> <td>3</td> <td></td><td></td><td>X</td><td></td> </tr> <tr> <td>1-1</td> <td>4</td> <td></td><td>X</td><td></td><td>X</td> </tr> <tr> <td>1-1</td> <td>5</td> <td></td><td></td><td>X</td><td></td> </tr> <tr> <td>1-1</td> <td>6</td> <td>X</td><td></td><td></td><td></td> </tr> <tr> <td>1-1</td> <td>7</td> <td></td><td>X</td><td></td><td></td> </tr> <tr> <td>1-1</td> <td>8</td> <td>X</td><td></td><td></td><td></td> </tr> </tbody> </table>	CONTACTS		HANDLE				END		1	2	3	4	ODD	EVEN					1-1	2		X		X	1-1	3			X		1-1	4		X		X	1-1	5			X		1-1	6	X				1-1	7		X			1-1	8	X																																																																																																																													
CONTACTS		HANDLE																																																																																																																																																																																						
END		1	2	3	4																																																																																																																																																																																			
ODD	EVEN																																																																																																																																																																																							
1-1	2		X		X																																																																																																																																																																																			
1-1	3			X																																																																																																																																																																																				
1-1	4		X		X																																																																																																																																																																																			
1-1	5			X																																																																																																																																																																																				
1-1	6	X																																																																																																																																																																																						
1-1	7		X																																																																																																																																																																																					
1-1	8	X																																																																																																																																																																																						

X In all contact diagrams denotes contacts closed

Contact Diagrams SB-1

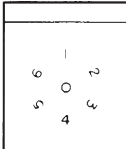
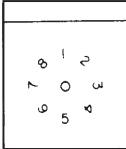
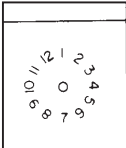
Fig #	DESCRIPTION	ESCUTCHEON & CONTACT DIAGRAM																																																																																																																																																																																																																																													
151	DOUBLE-POLE Six-throw Model No. 16SB1CG41 Oval handle	 <table border="1" data-bbox="867 394 1094 659"> <thead> <tr> <th colspan="2"></th> <th colspan="6">CONTACTS</th> </tr> <tr> <th colspan="2"></th> <th colspan="6">HANDLE</th> </tr> <tr> <th colspan="2"></th> <th colspan="6">END</th> </tr> <tr> <th rowspan="2">HANDLE</th> <th>ODD</th> <th colspan="6"></th> </tr> <tr> <th>EVEN</th> <th>1</th> <th>2</th> <th>3</th> <th>4</th> <th>5</th> <th>6</th> </tr> </thead> <tbody> <tr> <td>1</td> <td></td> <td></td> <td></td> <td></td> <td></td> <td></td> <td></td> </tr> <tr> <td>2</td> <td></td> <td></td> <td>X</td> <td></td> <td></td> <td></td> <td></td> </tr> <tr> <td>3</td> <td></td> <td></td> <td></td> <td>X</td> <td></td> <td></td> <td></td> </tr> <tr> <td>4</td> <td></td> <td></td> <td></td> <td></td> <td>X</td> <td></td> <td></td> </tr> <tr> <td>5</td> <td></td> <td></td> <td></td> <td></td> <td></td> <td>X</td> <td></td> </tr> <tr> <td>6</td> <td></td> <td></td> <td></td> <td></td> <td></td> <td></td> <td>X</td> </tr> </tbody> </table>			CONTACTS								HANDLE								END						HANDLE	ODD							EVEN	1	2	3	4	5	6	1								2			X					3				X				4					X			5						X		6							X																																																																																																																																																						
		CONTACTS																																																																																																																																																																																																																																													
		HANDLE																																																																																																																																																																																																																																													
		END																																																																																																																																																																																																																																													
HANDLE	ODD																																																																																																																																																																																																																																														
	EVEN	1	2	3	4	5	6																																																																																																																																																																																																																																								
1																																																																																																																																																																																																																																															
2			X																																																																																																																																																																																																																																												
3				X																																																																																																																																																																																																																																											
4					X																																																																																																																																																																																																																																										
5						X																																																																																																																																																																																																																																									
6							X																																																																																																																																																																																																																																								
152	DOUBLE-POLE Eight-throw Model No. 16SB1CG42 Oval handle	 <table border="1" data-bbox="870 800 1097 1115"> <thead> <tr> <th colspan="2"></th> <th colspan="8">CONTACTS</th> </tr> <tr> <th colspan="2"></th> <th colspan="8">HANDLE</th> </tr> <tr> <th colspan="2"></th> <th colspan="8">END</th> </tr> <tr> <th rowspan="2">HANDLE</th> <th>ODD</th> <th colspan="8"></th> </tr> <tr> <th>EVEN</th> <th>1</th> <th>2</th> <th>3</th> <th>4</th> <th>5</th> <th>6</th> <th>7</th> <th>8</th> </tr> </thead> <tbody> <tr> <td>1</td> <td></td> <td></td> <td></td> <td></td> <td></td> <td></td> <td></td> <td></td> <td></td> </tr> <tr> <td>2</td> <td></td> <td></td> <td>X</td> <td></td> <td></td> <td></td> <td></td> <td></td> <td></td> </tr> <tr> <td>3</td> <td></td> <td></td> <td></td> <td>X</td> <td></td> <td></td> <td></td> <td></td> <td></td> </tr> <tr> <td>4</td> <td></td> <td></td> <td></td> <td></td> <td>X</td> <td></td> <td></td> <td></td> <td></td> </tr> <tr> <td>5</td> <td></td> <td></td> <td></td> <td></td> <td></td> <td>X</td> <td></td> <td></td> <td></td> </tr> <tr> <td>6</td> <td></td> <td></td> <td></td> <td></td> <td></td> <td></td> <td>X</td> <td></td> <td></td> </tr> <tr> <td>7</td> <td></td> <td></td> <td></td> <td></td> <td></td> <td></td> <td></td> <td>X</td> <td></td> </tr> <tr> <td>8</td> <td></td> <td></td> <td></td> <td></td> <td></td> <td></td> <td></td> <td></td> <td>X</td> </tr> </tbody> </table>			CONTACTS										HANDLE										END								HANDLE	ODD									EVEN	1	2	3	4	5	6	7	8	1										2			X							3				X						4					X					5						X				6							X			7								X		8									X																																																																																																												
		CONTACTS																																																																																																																																																																																																																																													
		HANDLE																																																																																																																																																																																																																																													
		END																																																																																																																																																																																																																																													
HANDLE	ODD																																																																																																																																																																																																																																														
	EVEN	1	2	3	4	5	6	7	8																																																																																																																																																																																																																																						
1																																																																																																																																																																																																																																															
2			X																																																																																																																																																																																																																																												
3				X																																																																																																																																																																																																																																											
4					X																																																																																																																																																																																																																																										
5						X																																																																																																																																																																																																																																									
6							X																																																																																																																																																																																																																																								
7								X																																																																																																																																																																																																																																							
8									X																																																																																																																																																																																																																																						
153	DOUBLE-POLE Twelve-throw Model No. 16SB1CG43 Oval handle	 <table border="1" data-bbox="873 1220 1101 1650"> <thead> <tr> <th colspan="2"></th> <th colspan="12">CONTACTS</th> </tr> <tr> <th colspan="2"></th> <th colspan="12">HANDLE</th> </tr> <tr> <th colspan="2"></th> <th colspan="12">END</th> </tr> <tr> <th rowspan="2">HANDLE</th> <th>ODD</th> <th colspan="12"></th> </tr> <tr> <th>EVEN</th> <th>1</th> <th>2</th> <th>3</th> <th>4</th> <th>5</th> <th>6</th> <th>7</th> <th>8</th> <th>9</th> <th>10</th> <th>11</th> <th>12</th> </tr> </thead> <tbody> <tr> <td>1</td> <td></td> <td></td> <td></td> <td></td> <td></td> <td></td> <td></td> <td></td> <td></td> <td></td> <td></td> <td></td> <td></td> </tr> <tr> <td>2</td> <td></td> <td></td> <td>X</td> <td></td> <td></td> <td></td> <td></td> <td></td> <td></td> <td></td> <td></td> <td></td> <td></td> </tr> <tr> <td>3</td> <td></td> <td></td> <td></td> <td>X</td> <td></td> <td></td> <td></td> <td></td> <td></td> <td></td> <td></td> <td></td> <td></td> </tr> <tr> <td>4</td> <td></td> <td></td> <td></td> <td></td> <td>X</td> <td></td> <td></td> <td></td> <td></td> <td></td> <td></td> <td></td> <td></td> </tr> <tr> <td>5</td> <td></td> <td></td> <td></td> <td></td> <td></td> <td>X</td> <td></td> <td></td> <td></td> <td></td> <td></td> <td></td> <td></td> </tr> <tr> <td>6</td> <td></td> <td></td> <td></td> <td></td> <td></td> <td></td> <td>X</td> <td></td> <td></td> <td></td> <td></td> <td></td> <td></td> </tr> <tr> <td>7</td> <td></td> <td></td> <td></td> <td></td> <td></td> <td></td> <td></td> <td>X</td> <td></td> <td></td> <td></td> <td></td> <td></td> </tr> <tr> <td>8</td> <td></td> <td></td> <td></td> <td></td> <td></td> <td></td> <td></td> <td></td> <td>X</td> <td></td> <td></td> <td></td> <td></td> </tr> <tr> <td>9</td> <td></td> <td></td> <td></td> <td></td> <td></td> <td></td> <td></td> <td></td> <td></td> <td>X</td> <td></td> <td></td> <td></td> </tr> <tr> <td>10</td> <td></td> <td></td> <td></td> <td></td> <td></td> <td></td> <td></td> <td></td> <td></td> <td></td> <td>X</td> <td></td> <td></td> </tr> <tr> <td>11</td> <td></td> <td></td> <td></td> <td></td> <td></td> <td></td> <td></td> <td></td> <td></td> <td></td> <td></td> <td>X</td> <td></td> </tr> <tr> <td>12</td> <td></td> <td></td> <td></td> <td></td> <td></td> <td></td> <td></td> <td></td> <td></td> <td></td> <td></td> <td></td> <td>X</td> </tr> </tbody> </table>			CONTACTS														HANDLE														END												HANDLE	ODD													EVEN	1	2	3	4	5	6	7	8	9	10	11	12	1														2			X											3				X										4					X									5						X								6							X							7								X						8									X					9										X				10											X			11												X		12													X
		CONTACTS																																																																																																																																																																																																																																													
		HANDLE																																																																																																																																																																																																																																													
		END																																																																																																																																																																																																																																													
HANDLE	ODD																																																																																																																																																																																																																																														
	EVEN	1	2	3	4	5	6	7	8	9	10	11	12																																																																																																																																																																																																																																		
1																																																																																																																																																																																																																																															
2			X																																																																																																																																																																																																																																												
3				X																																																																																																																																																																																																																																											
4					X																																																																																																																																																																																																																																										
5						X																																																																																																																																																																																																																																									
6							X																																																																																																																																																																																																																																								
7								X																																																																																																																																																																																																																																							
8									X																																																																																																																																																																																																																																						
9										X																																																																																																																																																																																																																																					
10											X																																																																																																																																																																																																																																				
11												X																																																																																																																																																																																																																																			
12													X																																																																																																																																																																																																																																		

X In all contact diagrams denotes contacts closed

Specification Form GED-3933 has been designed for data-processing equipment and also to make it easier to fill out. Refer to page 64 and proceed as follows to fill out the form

1 FOR FACTORY USE ONLY (BLOCKS 9 THROUGH 18)

These blocks are for factory use only, and should be left blank.

2 CATALOG NUMBER (BLOCKS 19 THROUGH 25)

This number is assigned at the factory and these blocks should be left blank.

3 ACTION

This part of the form is broken into five sections, detailed under the five following points (4-8).

4 MAINTAINED ALL POSITIONS (BLOCK 26)

Put an "X" in this block if all the positions are maintained, and put in a dash (-) if they are not maintained.

5 SPRING RETURN FROM COUNTER-CLOCKWISE POSITIONS (BLOCKS 27 AND 28)

Put the number of the position the spring return action is *from* in Block 27 and the position the spring return is *to* in Block 28. Put in a dash when this action does not apply.

6 SPRING RETURN FROM CLOCKWISE POSITIONS (BLOCKS 29 AND 30)

Put the number of the position the spring return action is *from* in Block 29 and the position the spring return is *to* in Block 30. Put in a dash when this action does not apply.

7 MAINTAINED POSITION WITH SPRING RETURN (BLOCKS 31 THROUGH 34)

When you have the combination of maintained spring return action, the maintained positions are put in these blocks, starting with Block 31 and the lowest position number. Put a dash in the blocks that remain.

NOTE: With maintained and spring-return action, if Position 3 is being used, Position 3 is always a maintained position.

8 PULL-TO-LOCK (BLOCKS 35 AND 36)

When Pull-to-Lock is desired, the positions in which the handle is to be pulled and locked are indicated in these blocks. A dash is indicated in both blocks when Pull-to-Lock is *not* desired.

9 HANDLES (BLOCK 37)

Select the proper code letter (K, V, P, L

or N) to identify the type of handle desired. Indicate the appropriate letter in this block. The code letters A, B, C & D are used when a matching Type SB-1 handle is requested.

NOTE: For removable-type-handle switches, the code "N" for none is used, since removable handles are furnished as a separate item and are not furnished with the switch. See "Removable- Handles" Section.

10 ESCUTCHEONS (BLOCK 38)

Select the proper code letter (S, T, N, P or R) for the desired escutcheon, and put it in this block. When a keyed escutcheon is required for a removable handle, use the letter "R" and refer to Point 11, "Escutcheon Keyways". It should be noted that code "P" is a special escutcheon. This code is used when Lamicoid escutcheons are required. The description "Lamicoid" must also be specified in "Special Instructions" on the form as described in Point 17.

11 ESCUTCHEON KEYWAYS (BLOCKS 39 THROUGH 43)

These blocks are used only when a keyed escutcheon (Code R) is specified. Three keyways are normally used, and information in these blocks is generally assigned at the factory. See "Removable Handles" Section.

12 INTERMEDIATE POSITIONS (BLOCKS 44 THROUGH 51)

The SBM switch has eight position locations, with 45 degrees between positions. When 90 degree positioning is required, the 45-degree position location becomes an intermediate (non-feel) position. An "X" in one of the eight blocks above the positions indicates this position to be an intermediate position. See the section on "Overlapping (make-before-break) Contacts".

13 OPERATING REQUIREMENT

See the Table - The vertical numbers 1 to 20 are the contact numbers. The horizontal numbers, 1 through 8, are the position locations.

Put an "X" in the block under the position in which you want that contact to close. If that contact is to be open, leave the block blank. To the right of the table is a sketch of the standard escutcheon to aid in identifying the position locations on the switch.

When slip contacts are required, use the table on the right showing Position locations 1 through 5 only (as indicated). Under Position 3, there are two columns (2 and 4) to show if a contact is to be closed in Position 3 only when coming

from Position 2 or when coming from Position 4. Whatever contact action occurs in only Position 3 from 2 will also occur in Position 2 and 1 (when used), and whatever contact action occurs in only 3 from 4 will also occur in Position 4 and 5 (when used). Refer to "Slip Limitations" and how to overcome them before completing this part of the form. If a contact is not a slip contact and needs to close in Position 3, put an "X" in both columns under Position 3.

14 STOP LOCATIONS

At the bottom of the switch operating tables are Blocks number 1 through 8 and 1 through 6 which identify the stop locations. The stop locations are under the vertical lines between the positions.

Example: When using Positions 2, 3 and 4, circle stop location Number 2 to show that the handle is not to go to Position 1 from Position 2, and circle stop location Number 5 to show that the handle is not to go to Position 5 from Position 4. For 360 degree rotation, *do not* circle any stops.

15 CIRCUIT DESIGNATION ENGRAVING:

Specify the circuit designation desired in the 22 blocks following the blocks marked 108. A maximum of 22 characters can be specified.

16 ESCUTCHEON ENGRAVING

There are two lines of engraving available for each position (1 through 8), and a maximum of eight characters per line. If only one line is required, use the *top line*.

If a Position is to be blank, write ("BLANK") for that Position. When a target escutcheon is specified, leave Position 3 blank.

If the entire escutcheon is to be blank write "BLANK ESCUTCHEON" under "Special Instructions" (Point 17) at the bottom of the form.

17 SPECIAL INSTRUCTIONS

There are four rows of blocks to be used for any special instructions, such as the handle painted red, Lamicoid escutcheon for thick panel, blank escutcheon, jumpers, etc.

There are two types of Jumpers available for the SBM switch: Jumper 307V515 for contacts on the same stage, and Jumper 307V512 for jumpering contacts on adjacent stages.

NOTE: Jumpers are only furnished assembled, where required, on all standard listed switches. For unlisted switches, separate jumpers can be ordered.

Examples of Filled-Out Forms on Pages 57 & 58



This form may be photocopied for your convenience

SBM

"SPECIFICATION FORM" - GED-3933

1 STAGES 9 10 11 12 13 14 SLIPS 15 SHAFT POS. 16 17 18 J.M.P.R.S. & I

FOR FACTORY USE ONLY

2 CATALOG NO. (19-25)

3 ACTION MAINTAINED

4 ALL POSITIONS (YES-X NO--)

5 S.R. FROM C.C.W. POSITIONS

6 S.R. FROM C.W. POSITIONS

7 MAINT. POS. WITH SPR. RET.

8 PULL TO LOCK

9 KNURLED = K A B C
OVAL = V
PISTOL GRIP = P
LEVER = L
ROUND = R
NONE = N

10 STANDARD = S
TARGET = T
NONE = N
(SPECIAL) = P

11 ESCUTCHEON KEYWAYS

12 SBM SWITCH OPERATING REQUIREMENT TABLE

CONTACTS	POSITIONS		USE ONLY WHEN SLIP CONTACTS ARE REQUIRED		CONTACTS
	ODD	EVEN	5	4	
1					1
2					2
3					3
4					4
5					5
6					6
7					7
8					8
9					9
10					10
11					11
12					12
13					13
14					14
15					15
16					16
17					17
18					18
19					19
20					20

13 STOP LOCATIONS

14 STOP LOCATIONS

15 CK'T. DESIGNATION ENGRAVING, 22 LETTERS MAX.

16 ESCUTCHEON ENGRAVING (MAX. 2 LINES, 8 LETTERS PER LINE)

17 SPEC. INST.

18 GED-3933C

Fig. 65B A specification form for a three-position, breaker-control switch with spring return from Position 2 to Position 3, and from Position 4 to Position 3, pistol-grip handle, and target escutcheon required for thick panel (1-inch or 1-1/2 inch) slip con-tacts 1, 2, 7, 8 and 9. Note that Position 3 is not engraved when a target escutcheon is used.

SBM
"SPECIFICATION FORM" - GED-3933

1104

FOR FACTORY USE ONLY

SBM SWITCH OPERATING REQUIREMENT TABLE

CONTACTS	SBM SWITCH OPERATING REQUIREMENT TABLE		
	MARK	INTERMEDIATE	POS.
1			
2	X		
3	X		
4			
5	X		
6			
7	X		
8	X		
9	X		
10			
11			
12			
13			
14			
15			
16			
17			
18			
19			
20			

ESCUTCHEON ENGRAVING

TRIP

CLOSE

GE Power Management - Technology Center - 205 Great Valley Parkway - Malvern, PA 19355, USA - Phone (610) 251-7000

Fig. 65C A specification form for a four-position switch with maintained action, no handle, keyed escutcheon for removable handle with keys at Positions 2, 3, and 4, and 360° rotation (no stops) using only Positions 1, 3, 5, and 7 (intermediates at Positions 2, 4, 6, and 8).

SBM
"SPECIFICATION FORM" - GED-3933

1104

FOR FACTORY USE ONLY

SBM SWITCH OPERATING REQUIREMENT TABLE

CONTACTS	SBM SWITCH OPERATING REQUIREMENT TABLE		
	MARK	INTERMEDIATE	POS.
1			
2	X		
3	X		
4	X		
5			
6			
7	X		
8	X		
9			
10			
11			
12			
13			
14			
15			
16			
17			
18			
19			
20			

ESCUTCHEON ENGRAVING

A

B

C

D

GE Power Management - Technology Center - 205 Great Valley Parkway - Malvern, PA 19355, USA - Phone (610) 251-7000



Select either the SB-1/SB-9/SB-10 at the top of the order form and then follow the steps below.

SB-1/SB-9/SB-10

"ORDERING GUIDE" for Specification Form - GED-3934 - Part 1

1 HANDLE POSITION

The handle position location areas are shown front view, facing the handle. Select the desired degrees between positions and mark the position numbers. Going in a clockwise direction, Position 1 starts in the extreme counter-clockwise (CCW) position. When 360-degree rotation is required, Position 1 starts at 12 o'clock. Examples of notations see **pgs. 63-64**.

2 CONTACT ARRANGEMENT

The vertical columns on the left (numbers 1 to 32) are the contacts. The position numbers should be marked in the top column under "Handle Positions (Back View)". The term "Back View" means that the positions are read from right-to-left for the contact arrangement only.

An asterisk between the position number is used to indicate intermediate position to show the special contact action desired between the designated positions. Intermediate positions can be supplied on switches with 45° or more between positions (some types: 37-1/2°).

For information on Lateral Contacts see Section 9 & 10 on Specification Form - Part 1. For information on SLIP-CAMS see examples on Specification Ordering Guide - Part 2. Examples of notations see **Fig. 61A, 63-A and 65A**.

Examples of Filled-Out Forms on Page 66

3 CONTACT CONNECTIONS

Mark the contact connections desired for each stage in the manner shown.

ELECTRICALLY SEPARATE
(Supplied if connection type not specified)



ELECTRICALLY SEPARATE WITH COMMON TERMINAL



ELECTRICALLY COMMON WITHOUT COMMON TERMINAL FOR DOUBLE-BREAK ACTION



Examples of notations see **pg. 63**.

4 ENGRAVING

Under "Position", indicate the position numbers which are marked in the handle-position portion **1** of the form. Indicate the desired engraving for the position next to it under "Escutcheon Engraving". Maximum of 8 character spaces. The circuit designation, if desired, is marked in the circuit plate engraving block above the escutcheon engraving. Maximum of 22 character spaces.

5 HANDLES

Check the appropriate block to indicate the design of the handles desired. Available handle types are shown on page 3. Examples of notations see **pg. 63**.

6 ESCUTCHEONS

Check the block next to the desired escutcheon. For information and illustrations on the available escutcheons, refer to the Special Features Section in this publication. Target escutcheon is available only with spring return actions of 45° CW, 45° CCW, 75° CCW.

When a keyed escutcheon is checked, the position in which the handle is to be removable must be given, along with any other necessary information.

7 ROTATING ACTION

1. *Maintaining All Positions* - When the handle is maintained in all positions, check this block.

2. *Spring Return Action* - Can be provided from both directions to NORMAL, or from one direction to NORMAL.

Maintaining Position - When spring-return and maintained action is desired, both the spring-return positions, as per above, and the maintained positions should be marked.

3. *Pull-to-Lock In Position* - When a pull-to-lock action is desired fill-in the position number in which the handle is to be pulled and latched. Examples of notations see **Fig. 63D-63K**.

8 PANEL THICKNESS

Give the panel thickness in inches. This information is very important in selecting the proper shaft and spacers, however, it is frequently not specified. If the panel thickness is not given, the switch will be furnished for mounting on panels up to 3/16-inch thick. Most switches can be furnished for mounting in panels up to two-inches (32/16") thick.

LATERAL CONTACT SECTION for SB-10 SWITCHES Only:

9 LATERAL CONTACT STAGES

Complete this section only when ordering a Type SB-10 Switch which has both lateral and rotary contacts.

Examples of Filled-Out Forms on Page 66

To identify the lateral stages, mark a dot(s) to the far left outside of the contact connection diagram **3**. (Maximum: four lateral stages, two contacts per stage). Add "X" for each desired stage **9**. For each lateral stage used, avoid that stage in Contact Arrangement Table (in **2**).

Note: Do not put an "X" under the handle positions for these contacts. An "X" is used only for the rotary contacts.

10 LATERAL CONTACT ACTION

If you want to prevent rotary action in one of the lateral positions (either IN or OUT), cross out the other position. If you want rotary action in both the IN and OUT positions, cross out the word "NO" and add the designation "&" on the line between the words "IN" and "OUT".

If the handle is to be maintained in both the IN and OUT positions, cross out "Spring Return to IN/OUT".

If the handle is to spring return to either the IN or OUT position, cross out the undesired position and Maintaining "IN" "OUT".

When rotary action is spring return, you can only have lateral spring return action when the lateral action is in the "NORMAL" (rotary spring released) position. The maximum number of lateral contacts that can be provided to open with the lateral spring action is four.

First select the proper action ("Pull" or "Push") and write in the position in which this action is to take place, then, write in the contact numbers for the contact action desired. Refer to Table 2 - page 7 for the lateral action available. Refer to Fig. 65A for examples of notations.

For Options - See GED-3934 Form - Part 2



SB-1/SB-9/SB-10

"ORDERING GUIDE" for Specification Form - GED-3934 - Part 2

Fig. 61A: Examples of "SLIP-CAM" Contacts

	2	2N	1N	1
1			X	X
2			X	X

	2	2N	1N	1
1	X	X		
2	X	X		

	2	2N	1N	1
1	X	X		
2			X	X

	2	2N	1N	1
1			X	X
2	X	X		

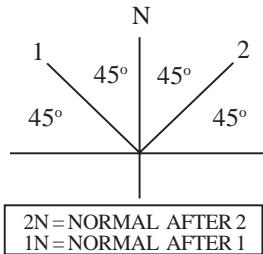

(See Section CAM Action and Limitations • See page 12)

	3	3N	2N	2	1
1			X	X	X
2			X	X	X

	3	3N	2N	2	1
1	X	X			
2	X	X			

	3	3N	2N	2	1
1	X	X			
2			X	X	X

	3	3N	2N	2	1
1			X	X	X
2	X	X			

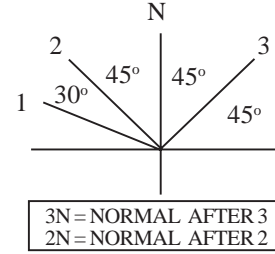

11 SPECIFYING OPTIONAL FEATURES

Certain optional features are available with the SB-1, -9 and -10 switches, but not necessarily to all of them. Determine whether the option you required is available with the type of switch you are specifying, and check the appropriate block as described below.

12 LOCK-IN HANDLE

Specify the position or positions in which the handle is to lock. All locks will be furnished with two keys, unless otherwise specified. (Not available with "Push or Pull to Lock"; nor "Push or Pull to Turn")

13 SEPARATELY MOUNTED LOCK

SB switches are available with a standard lock and key, or with a Kirk Key-Interlock System. Only one key "cut" is available with the standard lock. Two keys are furnished with each lock. Check the proper block. If Kirk Key-Interlock is checked, fill out the coordination information. Be sure the panel thickness is given.

The switch is furnished with the lock for mounting *above* the switch, as shown under standard mountings, and identified as Lock No. 1. Complete the description "Lock No. 1; locks and the key is removable in Pos.()". If mounting the lock above the switch is not feasible, or when two locks (each locking in a different position) are required, the locks can be mounted to the right, to the left, or below the switch.

To identify the location, the locks are numbers 2, 3 and 4 under "Special Mounting". Fill in the lock number in the description below and the position in which each lock is to lock.

The following Coordination Information
is required for utilizing the
Kirk Key-Interlock Scheme

To ensure a designated key change is furnished only to the customer and equipment assigned, the following information is required:

1. Fill-in the "Ultimate Customer's Name and Address", plus the name of the substation or building if applicable.

2. Provide the "Initial Purchase Order Number" of the coordinated Kirk locks presently installed to match the present key / lock scheme. If this is a new placement and a new key change is required, state it on your purchase order and we will document the new designated key change.

3. Provide the "Drawings of any Kirk Scheme Already Submitted" or a copy of the drawing. If the key change has already been assigned, as on reorders, specify the key change number.

Be sure this information is complete and correct when placing the order.

14 TANDEM SWITCHES

When a switch with more than 16 stages is required, two or more switches can be assembled in tandem, operating with one handle. The switches are normally mounted horizontally, but can also be furnished vertically mounted. Show the location of the switches and handle on the sketch provided for up to four switches in tandem. The corresponding switch numbers on the sketch should also be on the contact arrangement specification form. Draw in the handle to show its location, or specify the switch number on which the handle will be mounted. When more than four switches, or a different arrangement is required, use a separate sheet showing the proper switch arrangement.

Only the switch with handle can be provided as a "Pull to Lock" or SB-10.

15 PULL-TO-TURN/PUSH-TO-TURN

If the handle is to rotate in the "IN" position, indicate what position or positions; if it is not to rotate in the "IN" position, write "none". Fill in the position number in which the handle is to be pulled and state to what position, or positions, you will be rotating. Cross-out unwanted selections. For Push-to-Turn action fill-in a similar manner.

16 PALLADIUM CONTACTS

Check this block if required. Palladium contacts are available for temperature-meter switches (see "Temperature-meter Switches" - Page 17). If for a special application where some of the contacts are palladium, but not all, specify requirement in this block or on the contact arrangement.



This form may be photocopied for your convenience

SB-1/SB-9/SB-10

"SPECIFICATION FORM" GED-3934 - Part 2

Continued from Part 1

To be used with GED-3934 Form - Part 1

11 "OPTIONAL FEATURES"

12 LOCK-IN-HANDLE - [SB-1 or SB-9]

Corbin Lock Replacement
Handle Locks and Key Removable in Position (____)
Special (_____)

13 SEPARATELY MOUNTED LOCK - [SB-1, SB-9 or SB-10]

Standard Lock and Key
Kirk Key-Interlock Scheme

Coordination Information must be completed below when Kirk Lock is checked

Panel Thickness

STANDARD MOUNTING SPECIAL MOUNTING

No. 1 No. 2 No. 3
No. 4

Lock No. (1); Locks and Key is Removable in Pos. (____)
Lock No. (____); Locks and Key is Removable in Pos. (____)

The following coordination information is required for Kirk Key-Interlock Scheme

- Ultimate Customer's Name & Address

- Purchase Order of Coordinating Locks
P.O. No. _____
- Coordinating Information (KNOWN KEY No. & PRINT)

14 TANDEM SWITCH (Geared) - [SB-1, SB-9 or SB-10]

Vertically Mounted
Horizontally Mounted

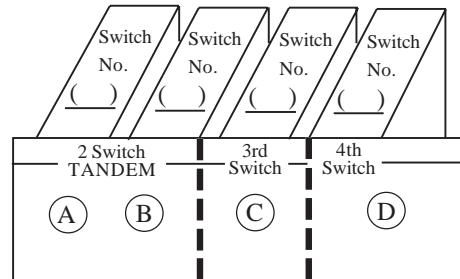

- Indicate the Switch No. required and cross-out the switch(es) not required.
- Use a separate form showing the proper switch arrangement for each switch above and write Switch No. on Specification Form - Part 1...
- Indicate Handle at location A, B, C, or D above.
- Indicate the type of handle on Specification Form (See Step 5).

A LARGE PISTOL GRIP HANDLE IS RECOMMENDED TO EASE IN TURNING TO VARIOUS POSITIONS

15 PULL-TO-TURN/PUSH-TO-TURN - [SB-1 or SB-9]

Rotates in Positions (____) when Handle is "IN"/"OUT"
PULL "OUT" / PUSH "IN" in Position (____)
to Rotate to Position (____)

16 PALLADIUM CONTACTS - [SB-1, SB-9 or SB-10] Check this block if Required

CHECK PROPER BLOCKS AND COMPLETE REQUIRED INFORMATION.

See Separate "Ordering Guide" for this "Specification Form" on Page 59

Examples of Filled-Out SB-1/SB-9/SB-10 Specification Forms

Some examples of correct and incorrect notations are shown here.

A common mistake is to show double-break contacts when they are not desired. **Fig. 63A.**

Here the requirement is clear that Contact 1 is closed in Position 1, that Contacts 1 and 2 are open in Position 2, and that Contact 2 closes in Position 3. However, with no common terminal, neither Position 1 nor Position 3 will make a circuit closure. There must be a common terminal as indicated in **Fig. 63B.**

When a double-break action is required, use the notation as indicated in **Fig. 63C.**

Fig. 63A: Examples of Completed Connections

INCORRECT

		3	2	1
	1			X
	2	X		

Fig. 63B

CORRECT

		3	2	1
	1			X
	2	X		

Fig. 63C

CORRECT

		3	2	1
	1	X		
	2	X		

SOME EXAMPLES OF INDICATING ROTATION ACTION

Fig. 63D

HANDLE POSITIONS (F.V.)

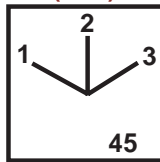

ROTATING ACTION	<input type="checkbox"/>
MAINTAINED ALL POSITIONS	
SPRING RETURN ACTION	
S. R. FROM CCW POS. S. R. FROM CW POS.	
FROM POS <input type="text" value="1"/> TO <input type="text" value="2"/> FROM POS <input type="text" value="3"/> TO <input type="text" value="2"/>	
MAINT. POS. <input type="text"/> <input type="text"/> <input type="text"/> <input type="text"/>	
PULL-TO-LOCK IN POS. _____	<input type="checkbox"/>

Fig. 63E

HANDLE POSITIONS (F.V.)

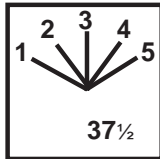

ROTATING ACTION	<input type="checkbox"/>
MAINTAINED ALL POSITIONS	
SPRING RETURN ACTION	
S. R. FROM CCW POS. S. R. FROM CW POS.	
FROM POS <input type="text" value="1"/> TO <input type="text" value="3"/> FROM POS <input type="text" value="5"/> TO <input type="text" value="3"/>	
MAINT. POS. <input type="text"/> <input type="text"/> <input type="text"/> <input type="text"/>	
PULL-TO-LOCK IN POS. _____	<input type="checkbox"/>

Fig. 63F

HANDLE POSITIONS (F.V.)

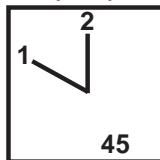

ROTATING ACTION	<input type="checkbox"/>
MAINTAINED ALL POSITIONS	
SPRING RETURN ACTION	
S. R. FROM CCW POS. S. R. FROM CW POS.	
FROM POS <input type="text" value="1"/> TO <input type="text" value="2"/> FROM POS <input type="text"/> TO <input type="text"/>	
MAINT. POS. <input type="text"/> <input type="text"/> <input type="text"/> <input type="text"/>	
PULL-TO-LOCK IN POS. _____	<input type="checkbox"/>

Fig. 63G

HANDLE POSITIONS (F.V.)

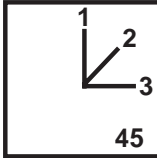

ROTATING ACTION		<input type="checkbox"/>
MAINTAINED ALL POSITIONS		

SPRING RETURN ACTION		
S. R. FROM CCW POS.		S. R. FROM CW POS.
FROM POS <input type="checkbox"/> TO <input type="checkbox"/>		FROM POS <input type="checkbox"/> TO <input type="checkbox"/>
MAINT. POS. <input type="checkbox"/> <input type="checkbox"/> <input type="checkbox"/> <input type="checkbox"/>		

PULL-TO-LOCK IN POS. _____ <input type="checkbox"/>		

Fig. 63H

HANDLE POSITIONS (F.V.)

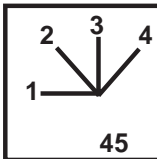

ROTATING ACTION		<input type="checkbox"/>
MAINTAINED ALL POSITIONS		

SPRING RETURN ACTION		
S. R. FROM CCW POS.		S. R. FROM CW POS.
FROM POS <input type="checkbox"/> TO <input type="checkbox"/>		FROM POS <input type="checkbox"/> TO <input type="checkbox"/>
MAINT. POS. <input type="checkbox"/> <input type="checkbox"/> <input type="checkbox"/> <input type="checkbox"/>		

PULL-TO-LOCK IN POS. _____ <input type="checkbox"/>		

Fig. 63I

HANDLE POSITIONS (F.V.)



ROTATING ACTION		<input type="checkbox"/>
MAINTAINED ALL POSITIONS		

SPRING RETURN ACTION		
S. R. FROM CCW POS.		S. R. FROM CW POS.
FROM POS <input type="checkbox"/> TO <input type="checkbox"/>		FROM POS <input type="checkbox"/> TO <input type="checkbox"/>
MAINT. POS. <input type="checkbox"/> <input type="checkbox"/> <input type="checkbox"/> <input type="checkbox"/>		

PULL-TO-LOCK IN POS. _____ <input type="checkbox"/>		

Fig. 63J

HANDLE POSITIONS (F.V.)



ROTATING ACTION		<input type="checkbox"/>
MAINTAINED ALL POSITIONS		

SPRING RETURN ACTION		
S. R. FROM CCW POS.		S. R. FROM CW POS.
FROM POS <input type="checkbox"/> TO <input type="checkbox"/>		FROM POS <input type="checkbox"/> TO <input type="checkbox"/>
MAINT. POS. <input type="checkbox"/> <input type="checkbox"/> <input type="checkbox"/> <input type="checkbox"/>		

PULL-TO-LOCK IN POS _____ <input checked="" type="checkbox"/>		

Fig. 63K

HANDLE POSITIONS (F.V.)

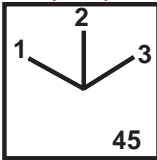

ROTATING ACTION		<input type="checkbox"/>
MAINTAINED ALL POSITIONS		

SPRING RETURN ACTION		
S. R. FROM CCW POS.		S. R. FROM CW POS.
FROM POS <input type="checkbox"/> TO <input type="checkbox"/>		FROM POS <input type="checkbox"/> TO <input type="checkbox"/>
MAINT. POS. <input type="checkbox"/> <input type="checkbox"/> <input type="checkbox"/> <input type="checkbox"/>		

PULL-TO-LOCK IN POS _____ <input checked="" type="checkbox"/>		

1 HANDLE POSITION **3 ON SB-10 SWITCHES MARK LAT. STAGES WITH A DOT (•)** **2 CONTACT ARRANGEMENTS**

CONTACTS HANDLE END ODD/EVEN	HANDLE POSITIONS (BACK VIEW)			
	1	2	1	2
• - - -				
• - - -				
• - - -				
• - - -				

LATERAL CONTACTS FOR SB-10 SWITCHES ONLY

9 LATERAL CONTACT STAGES **10 LATERAL CONTACT ACTION***
Cross Out the Action which does not apply

These areas are for indicating lateral contact stages only

1	2	1	2
• - - -	• - - -	X	
• - - -	• - - -		
• - - -	• - - -		
• - - -	• - - -		
• - - -	• - - -		
• - - -	• - - -		
• - - -	• - - -		

No Rotation when IN OUT
 Maintaining IN OUT
 Spring return to IN OUT
 To Close Contacts (2)
 To Open Contacts (- - - - - -)

1 HANDLE POSITION **3 ON SB-10 SWITCHES MARK LAT. STAGES WITH A DOT (•)** **2 CONTACT ARRANGEMENTS**

CONTACTS HANDLE END ODD/EVEN	HANDLE POSITIONS (BACK VIEW)			
	1	2	1	2
• - - -				
• - - -				
• - - -				
• - - -				
• - - -				
• - - -				
• - - -				
• - - -				

LATERAL CONTACTS FOR SB-10 SWITCHES ONLY

9 LATERAL CONTACT STAGES **10 LATERAL CONTACT ACTION***
Cross Out the Action which does not apply

These areas are for indicating lateral contact stages only

1	2	1	2
• - - -	• - - -	X	
• - - -	• - - -	X	
• - - -	• - - -		
• - - -	• - - -		
• - - -	• - - -		
• - - -	• - - -		
• - - -	• - - -		

No Rotation when IN OUT
 Maintaining IN OUT
 Spring return to IN OUT
 To Close Contacts (2)
 To Open Contacts (- - - - - -)

1 HANDLE POSITION **3 ON SB-10 SWITCHES MARK LAT. STAGES WITH A DOT (•)** **2 CONTACT ARRANGEMENTS**

CONTACTS HANDLE END ODD/EVEN	HANDLE POSITIONS (BACK VIEW)			
	1	2	1	2
• - - -				
• - - -				
• - - -				
• - - -				
• - - -				
• - - -				
• - - -				
• - - -				

LATERAL CONTACTS FOR SB-10 SWITCHES ONLY

9 LATERAL CONTACT STAGES **10 LATERAL CONTACT ACTION***
Cross Out the Action which does not apply

These areas are for indicating lateral contact stages only

1	2	1	2
• - - -	• - - -	X	
• - - -	• - - -		
• - - -	• - - -		
• - - -	• - - -		
• - - -	• - - -		
• - - -	• - - -		
• - - -	• - - -		

No Rotation when IN OUT
 Maintaining IN OUT
 Spring return to IN OUT
 To Close Contacts (- - - - - -)
 To Open Contacts (- - - - - -)

1 HANDLE POSITION **3 ON SB-10 SWITCHES MARK LAT. STAGES WITH A DOT (•)** **2 CONTACT ARRANGEMENTS**

CONTACTS HANDLE END ODD/EVEN	HANDLE POSITIONS (BACK VIEW)							
	8	7	6	5	4	3	2	1
• - - -								
• - - -								
• - - -								
• - - -								
• - - -								
• - - -								
• - - -								
• - - -								

LATERAL CONTACTS FOR SB-10 SWITCHES ONLY

9 LATERAL CONTACT STAGES **10 LATERAL CONTACT ACTION***
Cross Out the Action which does not apply

These areas are for indicating lateral contact stages only

1	2	1	2
• - - -	• - - -	X	
• - - -	• - - -	X	
• - - -	• - - -		
• - - -	• - - -		
• - - -	• - - -		
• - - -	• - - -		
• - - -	• - - -		

No Rotation when IN OUT
 Maintaining IN OUT
 Spring return to IN OUT
 To Close Contacts (- - - - - -)
 To Open Contacts (- - - - - -)

1 HANDLE POSITION **3 ON SB-10 SWITCHES MARK LAT. STAGES WITH A DOT (•)** **2 CONTACT ARRANGEMENTS**

CONTACTS HANDLE END ODD/EVEN	HANDLE POSITIONS (BACK VIEW)											
	12	11	10	9	8	7	6	5	4	3	2	1
• - - -												
• - - -												
• - - -												
• - - -												
• - - -												
• - - -												
• - - -												
• - - -												

LATERAL CONTACTS FOR SB-10 SWITCHES ONLY

9 LATERAL CONTACT STAGES **10 LATERAL CONTACT ACTION***
Cross Out the Action which does not apply

These areas are for indicating lateral contact stages only

1	2	1	2
• - - -	• - - -	X	
• - - -	• - - -	X	
• - - -	• - - -		
• - - -	• - - -		
• - - -	• - - -		
• - - -	• - - -		
• - - -	• - - -		

No Rotation when IN OUT
 Maintaining IN OUT
 Spring return to IN OUT
 To Close Contacts (- - - - - -)
 To Open Contacts (- - - - - -)

1 HANDLE POSITION **3 ON SB-10 SWITCHES MARK LAT. STAGES WITH A DOT (•)** **2 CONTACT ARRANGEMENTS**

CONTACTS HANDLE END ODD/EVEN	HANDLE POSITIONS (BACK VIEW)			
	4	3	2	1
• - - -				
• - - -				
• - - -				
• - - -				
• - - -				
• - - -				
• - - -				
• - - -				

LATERAL CONTACTS FOR SB-10 SWITCHES ONLY

9 LATERAL CONTACT STAGES **10 LATERAL CONTACT ACTION***
Cross Out the Action which does not apply

These areas are for indicating lateral contact stages only

1	2	1	2
• - - -	• - - -	X	
• - - -	• - - -	X	
• - - -	• - - -		
• - - -	• - - -		
• - - -	• - - -		
• - - -	• - - -		
• - - -	• - - -		

No Rotation when IN OUT
 Maintaining IN OUT
 Spring return to IN OUT
 To Close Contacts (- - - - - -)
 To Open Contacts (- - - - - -)

Figure 65A:
Examples of completed Lateral Action Forms for completing Specification Form for SB-10 Switches ONLY

SB-1/SB-9/SB-10

Examples of Completed Specification Forms - GED-3934

Select the Type of Switch Required:
 SB-1 SB-9 SB-10
 This form may be photocopied for your convenience

SB-1/SB-9/SB-10
 "SPECIFICATION FORM" GED-3934 - Part 1

1 HANDLE POSITIONS (Front View) Mark Position Numbers
 90° 90° 45° 37-1/2°
 SPECIAL 60° 30° 75°

2 CONTACT CONNECTIONS
 (HANDLE END) ODD/EVEN
 0 1 2 3 4 5 6 7 8 9 10 11 12 13 14 15 16 17 18 19 20 21 22 23 24 25 26 27 28 29 30 31 32

3 CONTACT ARRANGEMENT
 Mark "X" for Closed Contact
 Handle Positions (Back View)
 2 3 2 1

4 ENGRAVING
 Circuit Plate Engraving: **MOTOR SWITCH**
 Pos. Escutcheon Engraving
 1 OFF
 2 OFF
 3 Z

5 HANDLES
 Knurled
 Oval
 Pistol Grip
 Lever
 Round
 Radial
 L. Pistol grip
 None

6 ESCUTCHEON
 Standard or Round
 Target
 Removable Handle
 Keyed for Removable in Position ()

7 ROTATING ACTION
 Maintaining All Positions
 Spring Return Action
 S.R. from CCW Position From Pos () To ()
 S.R. from CW Position From Pos () To ()
 Maintaining Position ()
 Pull to Lock in Position ()

8 PANEL THICKNESS () 1/8" Specify Only in increments of 1/64 of an inch.

SPECIAL REMARKS:

9 LATERAL CONTACT STAGES
 Add "X" for Each Desired Lateral Stage.
 For Each Lateral Stage marked here, leave that stage blank in the Contact Arrangement Table. See 2.

10 LATERAL CONTACT ACTION* Check Out the Action which does not apply.
 No Rotation when IN OUT
 Maintaining IN OUT
 Spring return to IN OUT
 [PULL] [PUSH] In Position ()
 To Close Contacts ()
 To Open Contacts ()

* No Spring Return Lateral & Rotary Latches Locked in "N" Position.

GE Power Management - Technology Center - 205 Great Valley Parkway - Malvern, PA 19355, USA - Phone: (610) 251-7000
 GED-3934C - Part 1

Fig. 66A:

Example of a completed specification form, calling for a 3-stage SB-9 Switch, 3-position, maintained action, pistol grip handle, standard cover, and a panel thickness of 1/8 inch.

Fig. 66B:

Example of a completed specification form, calling for a 5-stage, 8-position SB-1 Switch with maintained action, knurled handle, standard cover and a panel thickness of 1/4 inch.

Select the Type of Switch Required:
 SB-1 SB-9 SB-10
 This form may be photocopied for your convenience

SB-1/SB-9/SB-10
 "SPECIFICATION FORM" GED-3934 - Part 1

1 HANDLE POSITIONS (Front View) Mark Position Numbers
 90° 90° 45° 37-1/2°
 SPECIAL 60° 30° 75°

2 CONTACT CONNECTIONS
 (HANDLE END) ODD/EVEN
 0 1 2 3 4 5 6 7 8 9 10 11 12 13 14 15 16 17 18 19 20 21 22 23 24 25 26 27 28 29 30 31 32

3 CONTACT ARRANGEMENT
 Mark "X" for Closed Contact
 Handle Positions (Back View)
 5 4 3 2 1

4 ENGRAVING
 Circuit Plate Engraving: **PUMP SWITCH**
 Pos. Escutcheon Engraving
 1 Pump 1
 2 Pump 2
 3 Pump 3
 4 Pump 4
 5 Pump 5

5 HANDLES
 Knurled
 Oval
 Pistol Grip
 Lever
 Round
 Radial
 L. Pistol grip
 None

6 ESCUTCHEON
 Standard or Round
 Target
 Removable Handle
 Keyed for Removable in Position ()

7 ROTATING ACTION
 Maintaining All Positions
 Spring Return Action
 S.R. from CCW Position From Pos (1) To (3)
 S.R. from CW Position From Pos (4) To (2)
 Maintaining Position ()
 Pull to Lock in Position ()

8 PANEL THICKNESS () 1/4" Specify Only in increments of 1/64 of an inch.

SPECIAL REMARKS:

9 LATERAL CONTACT STAGES
 Add "X" for Each Desired Lateral Stage.
 For Each Lateral Stage marked here, leave that stage blank in the Contact Arrangement Table. See 2.

10 LATERAL CONTACT ACTION* Check Out the Action which does not apply.
 No Rotation when IN OUT
 Maintaining IN OUT
 Spring return to IN OUT
 [PULL] [PUSH] In Position ()
 To Close Contacts ()
 To Open Contacts ()

* No Spring Return Lateral & Rotary Latches Locked in "N" Position.

GE Power Management - Technology Center - 205 Great Valley Parkway - Malvern, PA 19355, USA - Phone: (610) 251-7000
 GED-3934C - Part 1

Select the Type of Switch Required:
 SB-1 SB-9 SB-10
 This form may be photocopied for your convenience

SB-1/SB-9/SB-10
 "SPECIFICATION FORM" GED-3934 - Part 1

1 HANDLE POSITIONS (Front View) Mark Position Numbers
 90° 90° 45° 37-1/2°
 SPECIAL 60° 30° 75°

2 CONTACT CONNECTIONS
 (HANDLE END) ODD/EVEN
 0 1 2 3 4 5 6 7 8 9 10 11 12 13 14 15 16 17 18 19 20 21 22 23 24 25 26 27 28 29 30 31 32

3 CONTACT ARRANGEMENT
 Mark "X" for Closed Contact
 Handle Positions (Back View)
 3 7 4 5 4 3 2 1

4 ENGRAVING
 Circuit Plate Engraving: **MODE SELECTOR**
 Pos. Escutcheon Engraving
 1 1
 2 2
 3 3
 4 4
 5 5
 6 6
 7 7
 8 8

5 HANDLES
 Knurled
 Oval
 Pistol Grip
 Lever
 Round
 Radial
 L. Pistol grip
 None

6 ESCUTCHEON
 Standard or Round
 Target
 Removable Handle
 Keyed for Removable in Position ()

7 ROTATING ACTION
 Maintaining All Positions
 Spring Return Action
 S.R. from CCW Position From Pos () To ()
 S.R. from CW Position From Pos () To ()
 Maintaining Position ()
 Pull to Lock in Position ()

8 PANEL THICKNESS () 1/4" Specify Only in increments of 1/64 of an inch.

SPECIAL REMARKS:

9 LATERAL CONTACT STAGES
 Add "X" for Each Desired Lateral Stage.
 For Each Lateral Stage marked here, leave that stage blank in the Contact Arrangement Table. See 2.

10 LATERAL CONTACT ACTION* Check Out the Action which does not apply.
 No Rotation when IN OUT
 Maintaining IN OUT
 Spring return to IN OUT
 [PULL] [PUSH] In Position ()
 To Close Contacts ()
 To Open Contacts ()

* No Spring Return Lateral & Rotary Latches Locked in "N" Position.

GE Power Management - Technology Center - 205 Great Valley Parkway - Malvern, PA 19355, USA - Phone: (610) 251-7000
 GED-3934C - Part 1

Fig. 66C:

Example of a completed specification form, calling for an 8-stage SB-1 Switch, 5-position, spring return action (both directions), oval handle, standard cover, and a panel thickness of 1/8 inch.

SBM CONTROL SWITCH

FIELD MODIFICATION INSTRUCTIONS

CASE I-INSPECTING SWITCH ONLY

When the SBM switch is taken apart for inspection purposes only and is to be reassembled without modifications, follow this sequence:

1. Turn handle to vertical (12 o'clock position).
2. Remove handle and mounting screws.
3. Remove screws holding the front plate of positioning chamber.
4. Remove adjustable stops, noting relation of the punch mark on the operating shaft. This punch mark should be pointing towards the 90° ccw position (9 o'clock location).
5. Remove the stop spacers and positioning wheel. The balance of the parts in the front part of the chamber should be left intact*.
6. Use a 5/16" wrench to loosen the tie bolts in the rear of the switch. Back off the bolts only as far as necessary to loosen the positioning chamber from the balance of the assembly and remove chamber.
7. Push tie bolts back up against the rear barrier to keep the stages intact.
8. Turn operating shaft so that punch mark is not facing the bottom vertical (6 o'clock) position.
9. Remove the first stage front barrier cover.
10. Read the following before removing cams.

Note: Each stage houses two double surface cams. The first controls the action of the even number contact while the second cam controls the odd number contact. One cam is distinguished from another by a number (1 to 22) on one surface of the cam.

**On a control switch with a spring return feature there are no parts in the front half of the positioning chamber except the stop cams and a thick spacer. The rear half of this chamber houses the torsion spring. When the chamber is removed from the assembly the spring actuator, torsion spring and spacer will be up against the front barrier plate of the first stage of contacts. These parts should be removed and replaced in order. The balance of the steps for dismantling and reassembly remain the same.*

CASE II- CHANGING CONTACT SEQUENCE

If the SBM switch is to be taken apart and the contact sequence modified, follow the steps outlined in Case I. Omit step #11 since the cam locations in most cases will have to be changed to obtain the necessary sequence. The following are instructions necessary to select the new cams.

SET UP THE FOLLOWING TABLE

IBM CODE	1	2	4	1	2	4	1	2	CAM
POSITIONS	8	7	6	5	4	3	2	1	CODE
CONTACT #1	X	X		X	X	X		X	2 7 3
#2					X	X			0 6 0
#3	X		X				X	X	3 0 5
#4							X		1 0 0

The first line indicates the SBM coding system. The second line corresponds to the eight handle positions of the switch with position #1 at the 9 o'clock location and the balance of the positions in 45° intervals moving in a clockwise rotation. The contact diagram shown above indicates a sequence for a two-stage four-contact switch. Referring to the segment on the right, contact #1 is shown closed in position #1. Directly above position #1 is the IBM Code 2. Place this number in the extreme left column of the section marked Cam Code. In the next segment contact #1 is closed in positions 3, 4, 5; directly above these positions are the code number 1, 2 and 4. Their *sum* is the second digit of the cam code. In the third segment contact #1 is closed in positions 7 & 8, the code numbers above these two positions are 1 & 2. Their *sum* is the third digit of the code number. It can be seen that contact #2 is only closed in the second segment under positions 3 & 4 whose code is 2 & 4. There is no contact sequence in segments one and three so the first and last digit of the contact's code number will be zero. The middle digit will be 6, the sum of codes 2 & 4. The same method is used to find the cam code for contact 3 & 4.

Now that the cam codes have been derived, refer to the attached cam code sheets. One of these sheets is for the left-hand even number contacts and the other for the right-hand odd number contacts.

The cam code for contact #3 is 305. Refer to the Cam Code sheet for odd number contacts. Beside number 305 on *cam and position* is the listing 14G. This means cam #14 should be placed on the switch operating shaft so that the letter "G" passes over the punch mark. This will provide the sequence for contact #3 as shown in the diagram.

For contact #4 the cam code is 100. Beside this number on the sheet for left-hand even number contacts is the listing 16. Cam #1 should be placed on the operating shaft so that the letter "B" passes over the punch mark on the shaft. This will provide the sequence for contact #4 as shown in the diagram. The same procedure should be followed for contacts #1 and 2 whose codes are 273 and 060 and whose listings are 5F and 2C.

The switch can be now be reassembled by reversing the steps listed in Case I. Care must be exercised to make sure that the punch mark is returned to 9 o'clock position before placing the stop cams. This automatically places the handles in the 12 o'clock position and insures a correct sequence for the contacts.

SLIP CAMS

One cam not covered by this sequence is the slip cam for breaker control switches.

This cam is number 22 and can only be mounted on the operating shaft in two locations for proper contact sequence. When a slip cam is required to actuate a sequence as contact #1 or #2 in the table below, 22K is the cam code. When the sequence is to be as shown for contact #3, the cam code is 22D.

Switches which require a make-before-break (overlapping) sequence require special cams, only when three intermediate steps are required between each handle position. They cannot be modified therefore by using the code sheets. Requests for changes of this type should be referred back to the factory.

4	3 FROM		2	WHEN USED	
	4	2			
1		X	X		22K
2		X	X	X	22K
3	X	X			22D

SBM SWITCH CAM CODE (ODD NUMBER CONTACTS)

Contact Sequence Number	Cam Position	Contact Sequence Number	Cam Position	Contact Sequence Number	Cam Position	Contact Sequence Number	Cam Position	Contact Sequence Number	Cam Position	Contact Sequence Number	Cam Position	Contact Sequence Number	Cam Position	Contact Sequence Number	Cam Position
000		040	1L	100	1K	140	2L	200	1J	240	3L	300	2K	340	6L
001	1S	041	4L	101	3K	141	7L	201	2J	241	10J	301	6K	341	13H
002	1R	042	5L	102	4K	142	8L	202	3J	242	11L	302	7K	342	14H
003	2S	043	9S	103	10S	143	15H	203	6J	243	21H	303	13G	343	6H
004	1P	044	4P	104	5K	144	9L	204	4J	244	12L	304	8K	344	15L
005	3S	045	12S	105	11K	145	20E	205	7J	245	16F	305	14G	345	7H
006	2R	046	8R	106	9R	146	18E	206	10R	246	17F	306	15G	346	8H
007	6S	047	15S	107	21G	147	9H	207	13F	247	10H	307	6G	347	2H
010	1N	050	3N	110	4N	150	10L	210	5J	250	11N	310	9K	350	21B
011	4S	051	12N	111	12K	151	16H	211	8J	251	17H	311	15K	351	10B
012	3R	052	11R	112	12R	152	17B	212	11J	252	19F	312	20D	352	11H
013	7S	053	20B	113	16E	153	12H	213	14F	253	11F	313	7G	353	3H
014	2P	054	7P	114	8P	154	15C	214	9P	254	20H	314	18H	354	9C
015	10P	055	16C	115	17E	155	12C	215	15F	255	12F	315	8G	355	4H
016	6R	056	14D	116	15R	156	8D	216	21F	256	11D	316	9G	356	5H
017	13E	057	7E	117	10G	157	4E	217	6F	257	3F	317	2G	357	1H
020	1A	060	2A	120	3A	160	6A	220	4A	260	7A	320	10K	360	13A
021	5A	061	8A	121	11A	161	14A	221	9J	261	15A	321	21A	361	6A
022	4R	062	9A	122	12A	162	15A	222	12J	262	20F	322	16G	362	7A
023	8S	063	18F	123	17G	163	8A	223	15J	263	9A	323	10A	363	2A
024	3P	064	10M	124	11P	164	21C	224	12P	264	16A	324	17A	364	10C
025	11S	065	17C	125	19E	165	11A	225	20C	265	12A	325	11G	365	3A
026	7R	066	15D	126	20A	166	9D	226	16D	266	12D	326	12G	366	4A
027	14E	067	8E	127	11E	167	5E	227	7F	267	4F	327	3G	367	1A
030	2N	070	6N	130	7N	170	14B	230	8N	270	14B	330	15B	370	6B
031	9N	071	15N	131	20G	171	7B	231	18G	271	8B	331	9B	371	2B
032	10N	072	21D	132	16B	172	10D	232	17D	272	11B	332	12B	372	3B
033	15E	073	9E	133	12E	173	4B	233	8F	273	5F	333	4C	373	1B
034	6P	074	13C	134	14C	174	6C	234	15P	274	7C	334	8C	374	2C
035	21E	075	10E	135	11C	175	3C	235	9F	275	4C	335	5G	375	1C
036	13D	076	6D	136	7D	176	2D	236	10F	276	3D	336	4D	376	1D
037	6E	077	2E	137	3E	177	1E	237	2F	277	1F	337	1G	377	1H

Note: When cam code specifies the use of cam 1A, 2A, 3A, etc., the number on the cam should pass over the punch mark on the operation shaft since the letter "A" does not appear on the cams.

SBM SWITCH CAM CODE (EVEN NUMBER CONTACTS)

Contact Sequence Number	Cam Position	Contact Sequence Number	Cam Position	Contact Sequence Number	Cam Position	Contact Sequence Number	Cam Position	Contact Sequence Number	Cam Position	Contact Sequence Number	Cam Position	Contact Sequence Number	Cam Position	Contact Sequence Number	Cam Position
000		040	1L	100	1K	140	2L	200	1J	240	3L	300	2K	340	6L
001	1S	041	4L	101	3K	141	7L	201	2J	241	10J	301	6K	341	13H
002	1R	042	5L	102	4K	142	8L	202	3J	242	11L	302	7K	342	14H
003	2S	043	9S	103	10S	143	15H	203	6J	243	21H	303	13G	343	6H
004	1P	044	4P	104	5K	144	9L	204	4J	244	12L	304	8K	344	15L
005	3S	045	12S	105	11K	145	20E	205	7J	245	16F	305	14G	345	7H
006	2R	046	8R	106	9R	146	18E	206	10R	246	17F	306	15G	346	8H
007	6S	047	15S	107	21G	147	9H	207	13F	247	10H	307	6G	347	2H
010	1N	050	3N	110	4N	150	10L	210	5J	250	11N	310	9K	350	21B
011	4S	051	12N	111	12K	151	16H	211	8J	251	17H	311	15K	351	10B
012	3R	052	11R	112	12R	152	17B	212	11J	252	19F	312	20D	352	11H
013	7S	053	20B	113	16E	153	12H	213	14F	253	11F	313	7G	353	3H
014	2P	054	7P	114	8P	154	15C	214	9P	254	20H	314	18H	354	9C
015	10P	055	16C	115	17E	155	12C	215	15F	255	12F	315	8G	355	4H
016	6R	056	14D	116	15R	156	8D	216	21F	256	11D	316	9G	356	5H
017	13E	057	7E	117	10G	157	4E	217	6F	257	3F	317	2G	357	1H
020	1A	060	2A	120	3A	160	6A	220	4A	260	7A	320	10K	360	13A
021	5A	061	8A	121	11A	161	14A	221	9J	261	15A	321	21A	361	6A
022	4R	062	9A	122	12A	162	15A	222	12J	262	20F	322	16G	362	7A
023	8S	063	18F	123	17G	163	8A	223	15J	263	9A	323	10A	363	2A
024	3P	064	10M	124	11P	164	21C	224	12P	264	16A	324	17A	364	10C
025	11S	065	17C	125	19E	165	11A	225	20C	265	12A	325	11G	365	3A
026	7R	066	15D	126	20A	166	9D	226	16D	266	12D	326	12G	366	4A
027	14E	067	8E	127	11E	167	5E	227	7F	267	4F	327	3G	367	1A
030	2N	070	6N	130	7N	170	14B	230	8N	270	14B	330	15B	370	6B
031	9N	071	15N	131	20G	171	7B	231	18G	271	8B	331	9B	371	2B
032	10N	072	21D	132	16B	172	10D	232	17D	272	11B	332	12B	372	3B
033	15E	073	9E	133	12E	173	4B	233	8F	273	5F	333	4C	373	1B
034	6P	074	13C	134	14C	174	6C	234	15P	274	7C	334	8C	374	2C
035	21E	075	10E	135	11C	175	3C	235	9F	275	4C	335	5G	375	1C
036	13D	076	6D	136	7D	176	2D	236	10F	276	3D	336	4D	376	1D
037	6E	077	2E	137	3E	177	1E	237	2F	277	1F	337	1G	377	1H

SBM

Nomenclature Guide to Unlisted Switches

THE GUIDE BELOW IS FOR UNLISTED SWITCHES WHICH ARE NUMBERED AT THE FACTORY.
USE IT ONLY AS A GUIDE TO IDENTIFY CATALOG NUMBERS ASSIGNED BY THE FACTORY.
DO NOT USE IT TO MAKE UP CATALOG NUMBERS.

SBM SWITCH NOMENCLATURE EXPLANATION

16SBM	A	3	***	S	1A	2	P	1	***
	No. of Stages	No. of Positions	Seq No.	Escutcheon	Action	1st Stop Position	Handle	Panel Thickness	Escutcheon Keyways
A = 1	2 = 2	F A	S = STANDARD	S	K = KNURLED	1 = 0 - 1/4"	FACTORY ASSIGNED		
B = 2	3 = 3	A S	T = TARGET	E	V = OVAL	2 = 1", 1.5"	(Used with Escutcheon R only)		
C = 3	4 = 4	C S	P = TARGET (PULL TO LOCK)	E	P = PISTOL GRIP				
D = 4	5 = 5	T I	N = NONE	B	L = LEVER				
E = 5	6 = 6	O G	R = REMOVABLE HANDLE	E	A = SB1 KNURLED				
F = 6	7 = 7	R N		L	B = SB1 OVAL				
G = 7	8 = 8	Y E		O	C = SB1 PISTOL GRIP				
H = 8		D		W	D = SB1 ROUND				
K = 9					N = NONE				
L = 10									

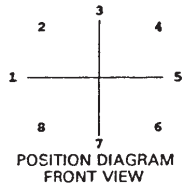

DESCRIPTION OF ACTION

MAINTAINED BOTH DIRECTIONS

- 1A - Positions 1, 2, 3, 4, 5, 6, 7, 8
- 2A - Positions 1, 3, 5, 7
- 3A - Positions 2, 4, 6, 8

SPRING RETURN TO POSITION 3 - CCW ONLY

- 1W - From position 2
- 2W - From position 1
- 3W - From position 1, (feel position 2)

SPRING RETURN TO POSITION 3 FROM BOTH DIRECTIONS

- 1S - Positions 2, 4
- 2S - Positions 1, 5
- 3S - Positions 1, 5 (feel position 2)
- 4S - Positions 1, 5 (feel position 4)
- 5S - Positions 1, 5 (feel positions 2 & 4)
- 1F - Pull to lock in position 1 (feel position 2)
- 2F - Pull to lock in position 2

SPRING RETURN TO POSITION 3 FROM CW MAINTAIN POSITION AT CCW

- 1H - From position 4, maintain position 1, 2
- 2H - From position 4, maintain position 1
- 3H - From position 5, maintain position 2
- 4H - From position 5, (feel pos. 4), maintain pos. 2
- 5H - From position 5, maintain position 1
- 6H - From position 5, (feel pos. 4), maintain pos. 1

SPRING RETURN TO POSITION 3 - FROM CW ONLY

- 1C - From position 4
- 2C - From position 5
- 3C - From position 5, (feel position 4)

SPRING RETURN TO POSITION 3 FROM CCW MAINTAIN POSITION AT CW

- 1K - From position 2, maintain position 4, 5
- 2K - From position 2, maintain position 5
- 3K - From position 1, maintain position 4
- 4K - From position 1, (feel pos. 2), maintain pos. 4
- 5K - From position 1, maintain position 5
- 6K - From position 1, (feel pos. 2), maintain pos. 5



16SB1 OR 16SB9

Nomenclature Guide to Unlisted Switches

THE GUIDE BELOW IS FOR UNLISTED SWITCHES WHICH ARE NUMBERED AT THE FACTORY. USE IT ONLY AS A GUIDE TO IDENTIFY CATALOG NUMBERS ASSIGNED BY THE FACTORY. DO NOT USE IT TO MAKE UP CATALOG NUMBERS.

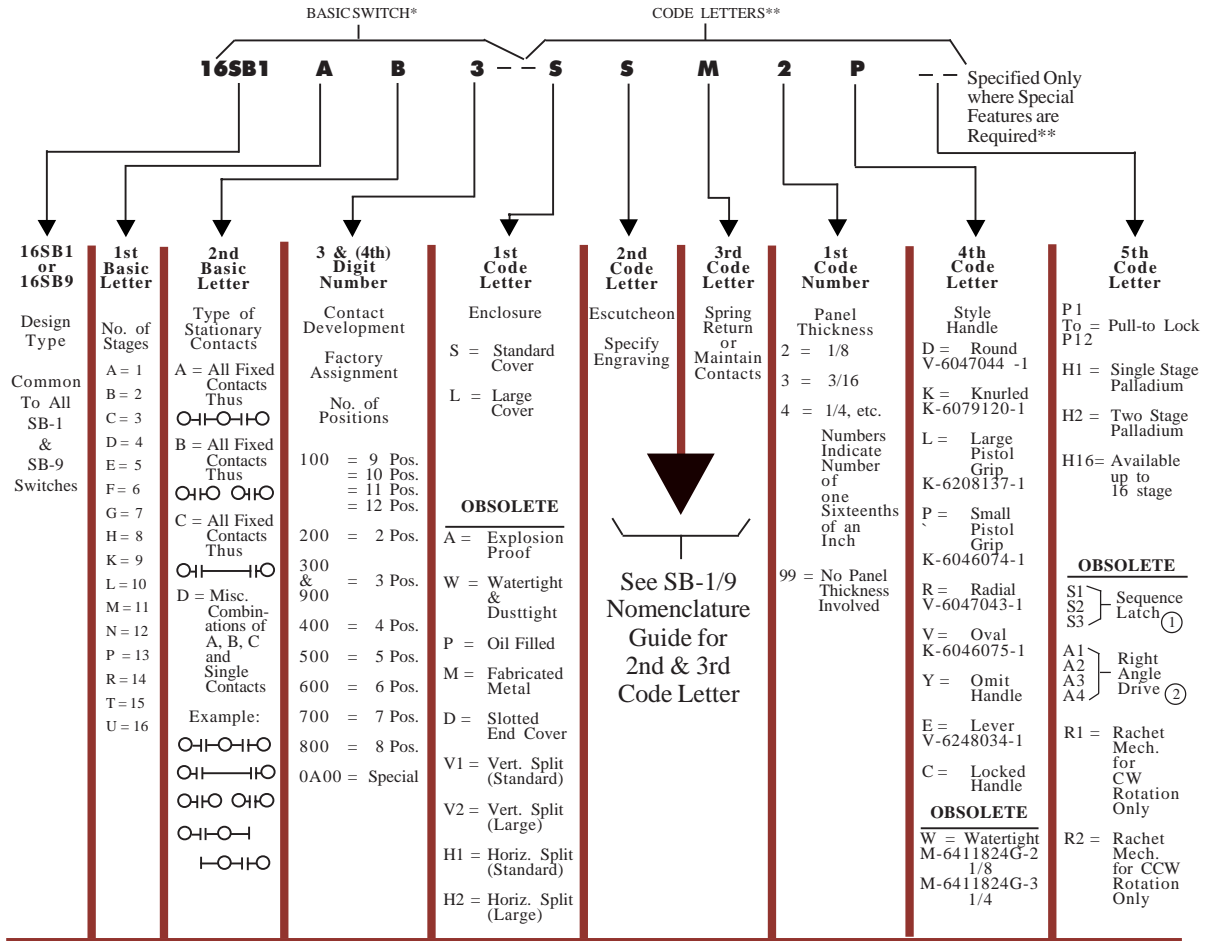

* Basic number assigned by factory engineers only to identify a special contact arrangement.

** Suffix added by factory engineers to complete switch to customer's specifications.

- ① S1 = Latching in CW & CCW positions
S2 = Will prevent repeated CCW throws
S3 = Will prevent repeated CW throws

- ② A1 = Switch mounted to the left
A2 = Switch mounted to the right
A3 = Switch mounted up
A4 = Switch mounted down

OBSOLETE: Shown for Reference Only



16SB1 OR 16SB9

Nomenclature Guide for 2nd and 3rd Code Letters

SB-1 or SB-9 2nd Code Letter				SB-1 3rd Code Letter		SB-9 3rd Code Letter	
ESCUTCHEON				SPRING RETURN AND MAINTAINING		SPRING RETURN AND MAINTAINING	
Code	Escutcheon Number	Typical Model Handle No.	Throw	Code	Description	Code	Description
Handle Removable in Vertical Position				Combination of Spring Return and Maintaining Contact		Maintaining Except	
A	6016164-3	16SB1CC1	135° CW	A	S.R. from 45° CW to Normal	A	S.R. from 45° CW to Normal
A	-3	CC18	360°	B	S.R. from 45° CCW to Normal	B	S.R. from 45° CCW to Normal
B	-4	CC2	135° CW	C	S.R. from 45° CW to Normal Δ (One Extra Stage)	C	Same as A - See *
B	-4	CC19	360°	D	S.R. from 45° CCW to Normal Δ (One Extra Stage)	D	Same as B - See *
C	-5	CC3	135° CW	E	S.R. from 90° CW to Normal	J	S.R. from 75° CW to 45° CW & from 75° CCW to 45° CCW
C	-5	CC15	360°	F	S.R. from 90° CCW to Normal		*Has 1 Extra Stage for Extra Spring
D	-6	CC4	135° CW	G	S.R. from 90° CW to Normal Δ (One Extra Stage)	Maintaining	
D	-6	CC11	45° CW & CCW	H	S.R. from 90° CCW to Normal Δ (One Extra Stage)	M	Maintaining Contact for all 45° Positions
D	-6	CC22	45° CCW	K	S. R. from 45° CW to Normal (Two Extra Stages) \oplus	N	Maintaining Contact for all 30° Positions
D	-6	CC27	360°	L	S.R. from 45° CCW to Normal (Two Extra Stages) \oplus	K	Maintaining Contact for 60° Positions
E	-7	CC5	45° CW	M	Maintaining Contacts	V	Maintaining Contact for all 37 1/2° Positions
E	-7	CC12	75° CW	Pull to Lock		L	Maintaining Contact for all 75° Positions
E	-7	CC13	45° CW & CCW	P	S.R. from 45° CW & CCW to Normal Pull to Lock in 45° CCW, Then Turn to 75° CCW & Pull to Lock	E	V 90°
E	-7	CC20	360°	R	S.R. all Positions Except When Locked, Pull to Lock at 75° CCW	F	+ 90°
E	-7	CC25	75° CCW	Spring Return Only		X	Special
F	-8	CC6	45° CW	Spring Return Only		Spring Return	
F	-8	CC14	45° CW & CCW	S	S.R. from all Positions to Normal	S	S.R. for all Combinations of 30°, 37 1/2°, 45°, 60°, 75°, 90° CW & CCW
F	-8	CC24	360°	T	S.R. from all Positions to Normal Δ (One Extra Stage)	T	Same as S - See * *Has 1 Extra Stage for Extra Spring
G	-9	CC7	45° CW "I" Eng.	U	S.R. from all Positions to Normal (Two Extra Stages) \oplus	Spring Return with Provision for Intermediate Temporary Contact Position at the Halfway Point.	
G	-9	CC8	45° CCW "R" Eng.	Abbreviations		U	S.R.- 90° CW & CCW Temp. Feel 30° & 60°
G	-9	CC17	45° CCW	S.R.	= Spring Return	W	S.R. from 90° CW or CCW or both
G	-9	CC26	135° CCW	CW	= Clockwise	Y	S.R. from 60° CW or CCW or both
G	-9	CC29	45° CW	CCW	= Counterclockwise	Z	S.R. from 75° CW or CCW or both
G	-9	CC21	360°	Symbols		Abbreviations	
H	-10	CC23	360°	Δ	= One Extra Stage for Torsion Spring	S.R.	= Spring Return
H	-10	CC9	45° CW "I" Eng.	\oplus	= Two Extra Stages for Additional Torsion Springs	CW	= Clockwise
H	-10	CC10	45° CCW "R" Eng.			CCW	= Counterclockwise
H	-10	CC31	45° CW				
H	-10	CC32	45° CCW				
J	-23	CC18	360°				
Y	-24	CC19	360°				
Z	-25	CC21	360°				
Handle Removable - 90° CCW							
K	6016164-11	16SB1CC1	135° CW				
K	-11	CC18	360°				
L	-12	CC2	135° CW				
L	-12	CC19	360°				
M	-13	CC3	135° CW				
M	-13	CC15	360°				
N	-14	CC11	45° CW & CCW				
N	-14	CC27	360°				
N	-14	CC4	135° CW				
N	-14	CC22	45° CCW				
Fixed Handle							
P	6016164-60	Pull to Lock (Target)					
R	6016164-15	Round					
S	6016164-1	Standard					
T	6402670G*	Target					
U	Omit Escutcheon						
V	Special Escutcheon						
Removable Handle							
W	Omit Escutcheon						
X(OO)	Special Escutcheon						

* [Number to be assigned]



MULTILIN

GE Power Management



NORTH AMERICA

*GE Multilin
215 Anderson Avenue
Markham, Ontario
Canada L6E 1B3
Tel: (905) 294-6222*

EUROPE

*GEPCE
Avenida Pinoa 10
48016 Zamudio Vizcaya
Spain
Tel: +34-4-485-8800*

GET-6169G

TCC-2.98-IntN