



# GCX, GCY, GCXY and GCXG

## Phase Packaged Directional-distance Relays

### GE Protective Relays

For Two, Three, and Four Zone Directional-distance Protection of Transmission Lines

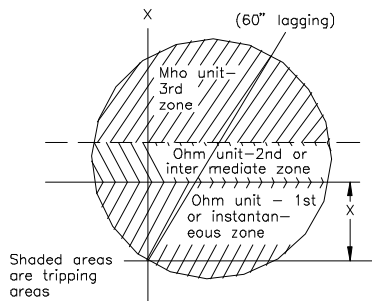

Fig. 1. Typical steady state operating characteristics. GCX51A relay

#### DESCRIPTION

**GCX51** is a family of single phase, three-zone phase packaged relays. The first - and second-zone distance measurements are made by a unit having a reactance of ohm type characteristic and the third zone has a directional mho characteristic. See Fig. 1 for R-X diagram.

**GCY51** is the type designation for a family of single phase two-zone and three-zone mho phase distance relays for transmission line protection. See Fig. 2 for R-X diagram.

A **GCY51F** is a single phase mho relay with two zones of protection. The M1 and M2 units have a 75° angle of maximum torque and M1 has provision for 0.5 ohm offset phase to neutral. The M2 unit has provision for a forward offset 0-4 ohms phase to neutral, thus giving a conventional two-zone relay or a distinctive "figure eight" characteristic as required. See Fig. 4 for R-X diagram.

The **GCXY51** is a single phase, four-zone phase distance relay with two zones or reactance characteristics. A third zone is provided by a unit having a directional mho characteristics, and a fourth zone is provided by unit with an offset (optional) mho characteristic. See Fig. 3 for R-X diagram.

#### Typical Terminal Package-60 Hz

3—GCX51M1A . . . . . 1-4 Ohm Range  
1—SAM . . . . . 48/110/125/220/250V DC

3—GCY51A1A . . . . . 0.75-30 Ohm Range  
1—SAM . . . . . 48/110/125/220/250V DC

3—GCY51F1A . . . . . 0.75-30 Ohm Range  
1—SAM . . . . . 48/110/125/220/250V DC

3—GCXY51A12D. . . . . 0.1-4 Ohm Range  
1—SAM . . . . . 48/110/125/220/250V DC

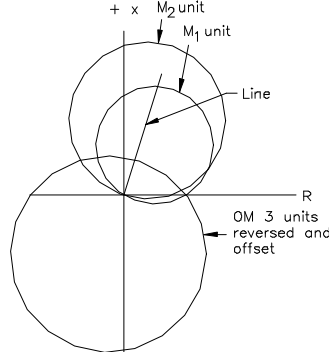

Fig. 2. Typical steady state operating characteristics GCY51A relay

#### APPLICATION—Phase Faults

Directional-distance relaying equipments provide high-speed protection for important transmission lines, and should be considered whenever other relaying is inadequate. The current level is seldom a factor in the time co-ordination of distance relaying. Therefore, changes in generating capacity or in the configuration of the system will not affect distance relaying and complicated short-circuit studies are unnecessary for their application. The length and the loading of a line determine the specific type of distance relay to be applied.

Short and Medium Lines are best protected by the Type GCX distance relay which operate on the reactance principle. Such relays are particularly applicable to short lines, where arc resistance can appreciably affect distance measurement by other means. Relay accuracy and insensitivity to transients permit instantaneous tripping over a maximum percentage of the protected line.

**Long Lines** are best protected by the GCY relay (popularly called the mho relay) because of its greater freedom from the adverse effect of tripping on power swings or loss of synchronism between generating stations.

For lines subject to power swings that are severe enough to affect even the mho-type relays, supplementary means are available to prevent improper operation during the system oscillations.

The GCY51A has 3 mho type units and provides three-zone time distance protection. The OM3 unit can be set in the forward or reversed direction and can be offset for either.

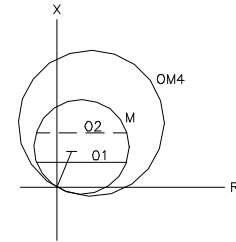

Fig. 3. Typical steady state operating characteristics. GCXY51 (OM4 shown without offset)

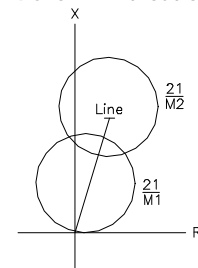

Fig. 4. Typical steady state operating characteristics. GCY51F

**Three-Zone Operation:** The GCX or GCY (phase-fault) relays in conjunction with a timing relay provide instantaneous operating time for up to 90 percent of the protected line section; a short time for the end zone (remaining 10 percent) and near end of the next section; and a longer time (backup) for faults on more distant sections.

The **GCY51F** has two Mho units, M1 and M2. With zero offset for the M2 unit, the relay provides regular two-zone protection. With the M2 unit offset in the forward direction, the relay can provide a very desirable "figure eight" characteristic with two-zone protection for long lines that may carry heavy loads. The M1 unit may be used to provide instantaneous tripping for a portion of the protected line and the M2 unit used with a timer to provide time delay backup tripping for the balance of the line and a portion of the next line section. The trip contacts of both units may be connected in parallel to provide the overreaching characteristic needed for directional comparison or transferred tripping pilot relaying schemes.



# GCX, GCY, GCXY and GCXG

## Phase Packaged Directional-distance Relays

### GE Protective Relays

#### APPLICATION--Phase Faults

The **GCXY51** phase distance relay is similar to the **GCY51A** except it has four zones of protection. Zone one is provided by a reactance unit, O1, under the supervision of the directional mho unit M. The second zone reactance characteristic, O2 is provided by the auxiliary unit OX which is picked up by the timer which extends the reach of the reactance unit. Zone three is provided by the mho unit M by a contact of the timer. The M units can also provide the carrier stop function by carrier auxiliary units. Initiation of carrier is by means of the normally closed contacts of OM, which would be connected to operate for faults in the reverse direction with offset. Thus, this relay is well suited for application in a step distance scheme or with directional comparison carrier.

#### GROUND FAULT PROTECTION

The three-zone **GCXG51A** relay is intended to provide step distance **ground** protection for transmission and distribution circuits. This relay is similar to the **GCX51** phase relay except it provides first- and second-zone protection for sin-

gle phase to ground faults plus third-zone protection for single phase to ground and double phase to ground faults. Also, the relay can provide instantaneous protection for up to 80 percent of the protected line section and a short time delay for the remaining 20 percent.

The **GCXG53A** ground distance relay is similar to the **GCXG51** except for use on **longer transmission lines**. Significant differences:

- The mho unit has an additional current circuit to provide zero sequence current compensation.
- The mho unit uses median voltage polarization.
- The mho unit is provided with an adjustment to vary the angle of maximum torque over the range of 60 to 75 degrees lag.

#### CONTACT RATING

The contacts of these relays will close and carry momentarily 30 amperes DC. However, the circuit breaker trip circuit must be opened by an auxiliary switch contact or other suitable means since the relay contacts have no interrupting rating.

#### BURDEN DATA

##### Maximum Potential Burdens (Total Relay)

| Relay        | Watts | Vo.  |       |
|--------------|-------|------|-------|
| GCX51A, B,H  | 30    | 31   | At    |
| GCX51M, N, R | 27    | 30   | 60Hz  |
| GCY51A       | 41.8  | 42.2 | 120V  |
| GCY5F        | --    | --   | 5 Amp |
| GCXY51A      | 42.3  | 45.8 | and   |
| GCXG51A      | 25.7  | 38.9 | 100%  |
| GCXG53A      | --    | --   | tap   |

For current burdens and potential burdens other than 100 percent tap. See instruction book for details.

##### Typical Ground Terminal Package for Normal and Short Lines

- 3-GCXG51A-A
- 1-SAM
- 1-NAA15E
- 1-0367 A0266G1 Aux. transf.

##### Typical Ground Terminal Package for Long Lines

- 3-GCXG53A-A
- 1-SAM
- 1-NAA15E
- 1-0367A0266G1 Aux.
- 1-0367A0266G2 trans

#### SELECTION GUIDE--3 Zone--phase Reactance

| Freq. Hz   | Control Volts Dc                                   | Mho Unit Range (Ohms) | Ohm Unit Range (O.N. Ohms) | Target Seal-in (Amps) | O.C. Unit Range (Range) | Model Number | Case Size | Approx. Wt. in lbs (KG) |          |
|--|--|-----------------------|----------------------------|-----------------------|-------------------------|--------------|-----------|-------------------------|----------|
|  |  |                       |                            |                       |                         |              |           | Net                     | Ship     |
| <b>STANDARD REACH--GCX51A-Mho Unit Angle of Max. Torque 60°</b>            |  |                       |                            |                       |                         |              |           |                         |          |
| 60   | 48/125/205   | 1-4                   | .25-10                     | 0.6/2.0               | ...                     | GCX51A23A    | L2        | 32                      | 38       |
|  |  | 2.5-10                | .25-10                     | 0.6/2.0               | ...                     | GCX51A12A    |           |                         |          |
|  |  | 2.5-10                | .25-10                     | 0.2/2.0               | ...                     | GCX51A13A    |           |                         |          |
|  |  | 2.5-10                | .5-20                      | 0.6/2.0               | ...                     | GCX51A24A    |           |                         |          |
| 50   | 48/125/250<br>48/110/220                           | 2.5-10                | .25-10                     | 0.6/2.0               | ...                     | GCX51A14A    | L2        | (14.5)                  | (17.2)   |
|  |  | 2.5-10                | .25-10                     | 0.6/2.0               | ...                     | GCX51A20A    |           |                         |          |
| <b>SHORT REACH--GCX51M-Mho Unit Angle of Max. Torque 60°</b>               |  |                       |                            |                       |                         |              |           |                         |          |
| 60   | 48/125/250   | 1-4                   | .1-4                       | 0.6/2.0               | ...                     | GCX51M1A     | L2        | 32                      | 38       |
| 50   | 48/125/250<br>48/110/220<br>48/110/220             | 1-4                   | .1-4                       | 0.2/2.0               | ...                     | GCX51M2A     |           |                         |          |
|  |  |                       |                            | 0.6/2.0               | ...                     | GCX51M3A     |           |                         |          |
|  |  |                       |                            | 0.6/2.0               | ...                     | GCX51M4A     |           |                         |          |
|  |  |                       |                            | 0.2/2.0               | ...                     | GCX51M5A     |           | (14.5)                  | (17.2)   |
| <b>STANDARD REACH--GCX51B--Same as GCX51A Except with Inst. O.C. Unit</b>  |  |                       |                            |                       |                         |              |           |                         |          |
| 60   | 48/125/250   | 2.5-10                | .25-10                     | 0.6/2.0               | 4-16                    | GCX51B12A    | L2        | 32                      | 38       |
|  |  |                       |                            | 0.6/2.0               | 2-8                     | GCX51B13A    |           |                         |          |
| 50   | 48/125/250   | 2.5-10                | .25-10                     | 0.6/2.0               | 1-4                     | GCX51B14A    |           |                         |          |
|  |  |                       |                            | 0.2/2.0               | 2-8                     | GCX51B16A    |           |                         |          |
|  |  |                       |                            | 0.6/2.0               | 2-8                     | GCX51B15A    |           | (15.4)                  | (18.1)   |
|  |  |                       |                            | 0.6/2.0               | 4-16                    | GCX51B20A    |           |                         |          |
| <b>SHORT REACH--GCX51N--Same as GCX51M Except with Inst. O.C. Unit</b>     |  |                       |                            |                       |                         |              |           |                         |          |
| 60   | 48/125/250<br>24/48/125<br>24/48/125<br>48/125/250 | 1-4                   | .1-4                       | 0.6/2.0               | 4-16                    | 12GCX51N1A   | L2        | 34                      | 40       |
|  |  |                       |                            | 0.6/2.0               | 4-16                    | 12GCX51N3A   |           |                         |          |
|  |  |                       |                            | 0.6/2.0               | 10-40                   | 12GCX51N4A   |           |                         |          |
|  |  |                       |                            | 0.2/2.0               | 4-16                    | 12GCX51N6A   |           |                         |          |
| 50   | 48/125/250<br>24/48/125                            | 1-4                   | .1-4                       | 0.6/2.0               | 4-16                    | 12GCX51N2A   | L2        | (15.4)                  | (18.1)   |
|  |  |                       |                            | 0.6/2.0               | 2-8                     | 12GCX51N5A   |           |                         |          |
| <b>STANDARD REACH--GCX51H--Same As GCX51A Except 75° Angle Max. Torque</b> |  |                       |                            |                       |                         |              |           |                         |          |
| 60   | 48/125/250   | 2.5-10                | .25-1                      | 0.6/2.0               | ...                     | GCX51H2A     | L2        | 34(15.4)                | 40(18.1) |
| <b>SHORT REACH--GCX51R--Same as GCXM Except 75° Angle Max. Torque</b>      |  |                       |                            |                       |                         |              |           |                         |          |
| 60   | 48/125/250   | 1-4                   | .1-4                       | 0.6/2.0               | ...                     | GCX51R1A     | L2        | 34(15.4)                | 40(18.1) |



# GCX, GCY, GCXY and GCXG

## Phase Packaged Directional-distance Relays

### GE Protective Relays

#### SELECTION GUIDE --- 3 Zone Ground Distance

| AC Rating  | Control Volts DC         | Mho Unit Phase-Neut. Range Ohms | Target Seal-in Amp | Ohm-Unit Phase-Neut. Ohms | Model Number | Required Per Terminal                              | Case Size | Approx. Wt. Lb(Kg) |          |
|--|--------------------------|---------------------------------|--------------------|---------------------------|--------------|--|-----------|--------------------|----------|
|  |                          |                                 |                    |                           |              |  |           | Net                | Ship     |
| <b>TYPE GCXG51--With 60° Max. Torque Angle</b>                                       |                          |                                 |                    |                           |              |  |           |                    |          |
| 60Hz<br>120V<br>5 Amp.<br>and<br>70V<br>5 Amp.<br>Rest.                              | 48/125/250               | 1-30                            | 0.6/2              | 0.1-4                     | GCXG51A11A   | 3-GCXG<br>1-SAM<br>1-NAA15<br>1-Aux Trans(3)①      | L2        | 34(15.4)           | 40(18.1) |
|  |                          | 1-30                            | 0.6/2              | 0.25-10                   | GCXG51A12A   |  |           |                    |          |
|  |                          | 2-60                            | 0.6/2              | 0.5-20                    | GCXG51A15A   |  |           |                    |          |
|  |                          | 1-30                            | 0.2/2              | 0.25-10                   | GCXG51A13A   |  |           |                    |          |
| 50Hz<br>120V<br>5 Amp.<br>and<br>70V<br>5 Amp.<br>Rest.                              | 24/48/125<br>24/48/125   | 1-30                            | 0.6/2              | 0.1-4                     | GCXG51A23A   |  |           |                    |          |
|  |                          | 1-30                            | 0.6/2              | 0.25-10                   | GCXG51A22A   |  |           |                    |          |
|  |                          | 1-30                            | 0.6/2              | 0.25-10                   | GCXG51A16A   |  |           |                    |          |
|  |                          | 1-30                            | 0.6/2              | 0.25-10                   | GCXG51A24A   |  |           |                    |          |
|  |                          | 2-60                            | 0.6/2              | 0.5-20                    | GCXG51A21A   |  |           |                    |          |
| <b>Type GCXG53--3 Zone Ground Distance--Long Lines with 60/75° Max. Torque Angle</b> |                          |                                 |                    |                           |              |  |           |                    |          |
| 60 Hz<br>120V<br>5 Amp.<br>and<br>70V<br>5 Amp.<br>Rest.                             | 48/125/250               | 1-30                            | 0.6/2              | 0.25-10                   | GCXG53A3A    | 3-GCXG53<br>1-SAM14<br>1-NAA15<br>2-Aux Transf(4)① | L2        | 34(15.4)           | 40(18.1) |
|  |                          | 1-30                            | 0.2/2              | 0.25-10                   | GCXG53A2A    |  |           |                    |          |
|  |                          | 2-60                            | 0.6/2              | 0.5-20                    | GCXG53A1A    |  |           |                    |          |
|  |                          |                                 |                    |                           |              |  |           |                    |          |
| 50 Hz<br>120V<br>5 Amp.<br>and<br>70V<br>5 Amp.<br>Rest.                             | 48/125/250<br>48/125/250 | 1-30                            | 0.6-2              | 0.1-4                     | GCXG53A5A    |  |           |                    |          |
|  |                          | 1-30                            | 0.6-2              | 0.25-10                   | GCXG53A4A    |  |           |                    |          |
|  |                          | 1-30                            | 0.6-2              | 0.25-10                   | GCXG53A6A    |  |           |                    |          |
|  |                          |                                 |                    |                           |              |  |           |                    |          |

①NOTES:

- (1) For SAM and other timing relays, See Section 6.
- (2) For NAA15 auxiliaries. See page 3-13.
- (3) **One** auxiliary transformer No. 0367A0266G1 required for each terminal of GCXG51 relays.
- (4) For GCXG53 terminal--**one** No. 0367A0266G1 and **one** 0367A0266G2.

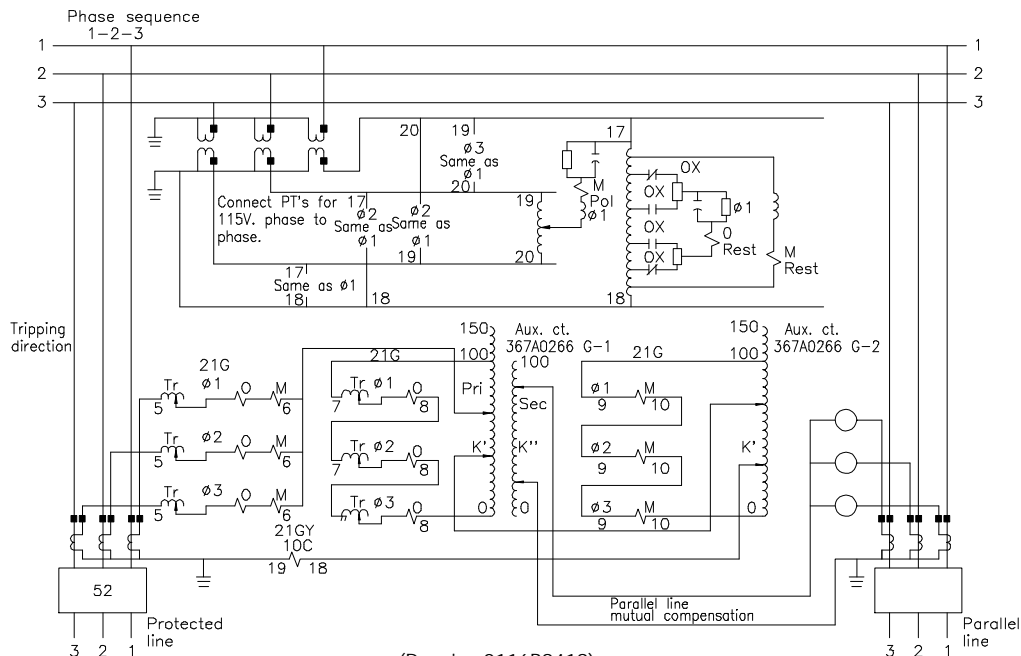

(Drawing O116B9419)  
**Fig. 5. Typical External Connections**  
**Three GCXG53A per Terminal**

### Transmission Line Relays



# GCX, GCY, GCXY and GCXG

## Phase Packaged Directional-distance Relays

### GE Protective Relays

#### SELECTION GUIDE--4 Zone Phase Distance

60/75° Max. Torque Angle M Unit – 75° Max. Torque Angle OM Unit

TYPE GCXY51 – 1st and 2nd Zone Reactance, 3rd and 4th Mho Distance

| AC Rating              | Control Volts DC         | Unit Phase-Neut. Ohms | Mho Units Phone-Neut. Ohms |              | OM Offset Ohms  | Target Seal-in Amp. | Model Number             | Required Per Terminal | Case Size | Approx Wt(Kg) |          |
|------------------------|--------------------------|-----------------------|----------------------------|--------------|-----------------|---------------------|--------------------------|-----------------------|-----------|---------------|----------|
|                        |                          |                       | M                          | OM           |                 |                     |                          |                       |           | Net           | Ship     |
| 60 Hz<br>120V<br>5 Amp | 48/125/250<br>48/125/250 | 0.1-4<br>0.25-10      | 1-12<br>1-12               | 3-30<br>3-30 | 0-0.5<br>0-0.05 | 0.6/2<br>0.6/2      | GCXY51A12D<br>GCXY51A11D | 3-GCXY<br>1-SAM       | L2D       | 43(19.5)      | 50(22.7) |

#### 3 Zone Phase Mho Distance

| AC Rating | Mho Units Phase to Neutral Ohms |    |     | OM3 Offset Ohms | Maximum Torque |     | Target Seal-in Amp. | Model Number | Required Per Terminal | Case Size | Approx Wt Lb(Kg) |      |
|-----------|---------------------------------|----|-----|-----------------|----------------|-----|---------------------|--------------|-----------------------|-----------|------------------|------|
|           | M1                              | M2 | OM3 |                 | M1             | OM3 |                     |              |                       |           | Net              | Ship |

#### TYPE GCY51A

|                        |         |      |      |       |     |     |                |                             |                |    |          |          |
|------------------------|---------|------|------|-------|-----|-----|----------------|-----------------------------|----------------|----|----------|----------|
| 60 Hz<br>120V<br>5 Amp | 0.75-30 | 1-30 | 3-30 | 0-0.5 | 60° | 75° | 0.6/2<br>0.2/2 | GCY51A1A<br>GCY51A2A<br>A2A | 3-GCY<br>1-SAM | L2 | 42(19.1) | 49(22.2) |
|                        | 0.75-30 | 1-30 | 3-30 | 0-0.5 | 60° | 75° |                |                             |                |    |          |          |
| 50 Hz<br>120V<br>5 Amp | 0.75-30 | 1-30 | 3-30 | 0-0.5 | 60° | 75° | 0.6/2          | GCY51A3A                    |                | L2 | 42(19.1) | 49(22.2) |

#### TYPE GCY51D—Similar to GCY51A—Except M2—75° Max. Torque Angle

|                        |         |      |      |       |           |                  |       |          |                |    |          |          |
|------------------------|---------|------|------|-------|-----------|------------------|-------|----------|----------------|----|----------|----------|
| 60 Hz<br>120V<br>5 Amp | 0.75-30 | 1-30 | 3-30 | 0-0.5 | M1<br>60° | M2<br>OM3<br>75° | 0.6/2 | GCY51D1A | 3-GCY<br>1-SAM | L2 | 42(19.1) | 49(22.2) |
|------------------------|---------|------|------|-------|-----------|------------------|-------|----------|----------------|----|----------|----------|

#### TYPE GCY51H—Similar to GCY51A—Except all units 75° Max. Torque Angle

|                        |         |      |      |       |     |     |       |          |                |    |          |          |
|------------------------|---------|------|------|-------|-----|-----|-------|----------|----------------|----|----------|----------|
| 50 Hz<br>120V<br>5 Amp | 0.75-30 | 1-30 | 3-30 | 0-0.5 | 75° | 75° | 0.6/2 | GCY51H3A | 3-GCY<br>1-SAM | L2 | 42(19.1) | 49(22.2) |
|------------------------|---------|------|------|-------|-----|-----|-------|----------|----------------|----|----------|----------|

#### TYPE GCY51F—2 Zone Phase Mho or "Figure 8"

| AC Rating               | Mho Units Phase to Neut. Ohms |      | M1 Offset Ohms | M2 Offset Ohms | Maximum Torque |     | Target Seal-in Amp. | Model Number | Required Per Terminal | Case Size | Approx. Wt Lb(Kg) |        |
|-------------------------|-------------------------------|------|----------------|----------------|----------------|-----|---------------------|--------------|-----------------------|-----------|-------------------|--------|
|                         | M1                            | M2   |                |                | M1             | M2  |                     |              |                       |           | Net               | Ship   |
| 60 Hz<br>120V<br>10 Amp | 0.75-30                       | 1-30 | 0-0.5          | 0-4            | 75°            | 75° | 0.6/2               | GCY51F1A     | 3-GCY<br>1-SAM        | L2        | 38(17.2)          | 44(20) |

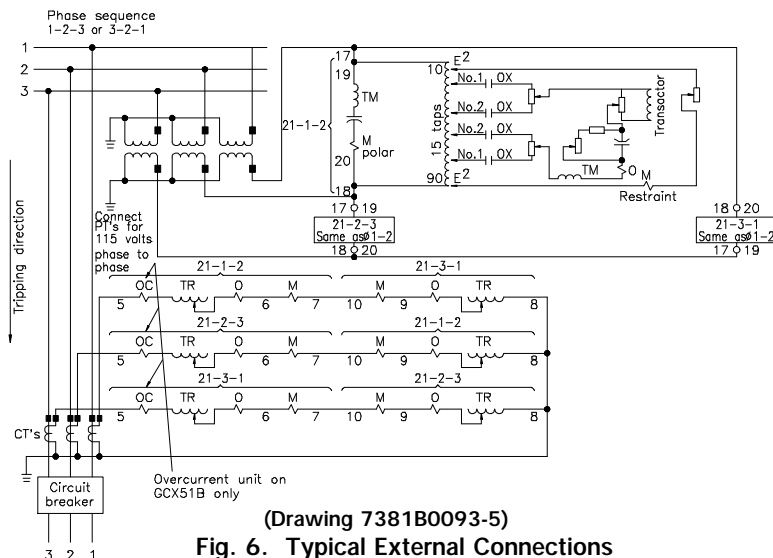

Fig. 6. Typical External Connections  
Three GCX51A or 51B per Terminal

Transmission Line Relays