

# F35

## Universal Gas-Insulated Substation 145 kV, 40 kA, 3 150 A

GE makes the most of 50 years of experience in design, material selection, development, engineering, manufacturing and servicing of gas-insulated substations.

GE's F35 GIS meet the challenges of networks up to 145 kV for all applications: power generation, transmission, distribution, tertiary and heavy industry.

### Go Green

- SF<sub>6</sub>-free solution with g<sup>3</sup>
- The lowest CO<sub>2</sub> impact on the whole life cycle thanks to g<sup>3</sup>
- Same performance and ratings with SF<sub>6</sub> or with g<sup>3</sup>
- Same dimensions with SF<sub>6</sub> or g<sup>3</sup>, and with the smallest footprint on market
- 1<sup>st</sup> choice in SF<sub>6</sub>-free 145 kV GIS: to date 70 bays ordered by 11 utilities

### Go Digital

- Create the GIS bays you want: from all conventional to all digital. All monitoring and control solutions are available.
- "A la carte" configuration: scalable solution allowing a step by step integration of digital devices
- Flexible solution: no need to set instrument transformers parameters early, thanks to LPIT
- Communication and cybersecurity: all Intelligent Electronic Devices (IEDs) support the industry leading protocols like IEC 61850 and integrate cybersecurity features to answer users specific requirements
- Asset Management: all GIS digital monitoring systems are key contributors to Asset Performance Management (APM) systems

### Make Your Life Easier With a Universal Solution

- Always the same design whatever your constraints and operational choices: SF<sub>6</sub> or g<sup>3</sup>, conventional or Low Power Instrument Transformers (LPIT), other digital options...
- Easy engineering and project planning: always the same size and implementation process
- Easy handling: always the same operation and maintenance procedures
- Easy extensions: bay size remains identical whatever the options



### Go Green

- SF<sub>6</sub>-free GIS with g<sup>3</sup>
- Lowest CO<sub>2</sub> footprint along Life Cycle
- Same performances as SF<sub>6</sub>

### Go Digital

- Low Power Instrument Transformer
- Monitoring
- Control
- Protection

### Make Your Life Easier

- The most compact design, applicable to all cases

F35 - 145 kV, 40 kA, 3150 A - Double busbar diagram

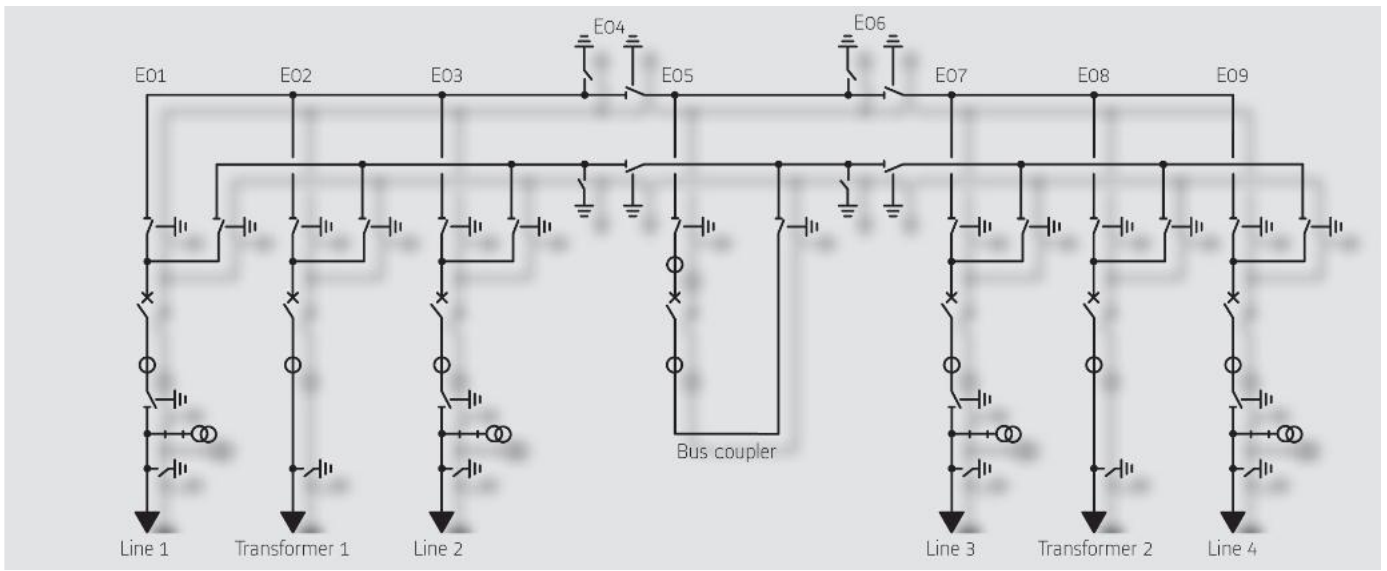

Bay width: 800 mm

Also available:

- Other single-line diagrams
- Standalone control cubicles
- Specific layouts

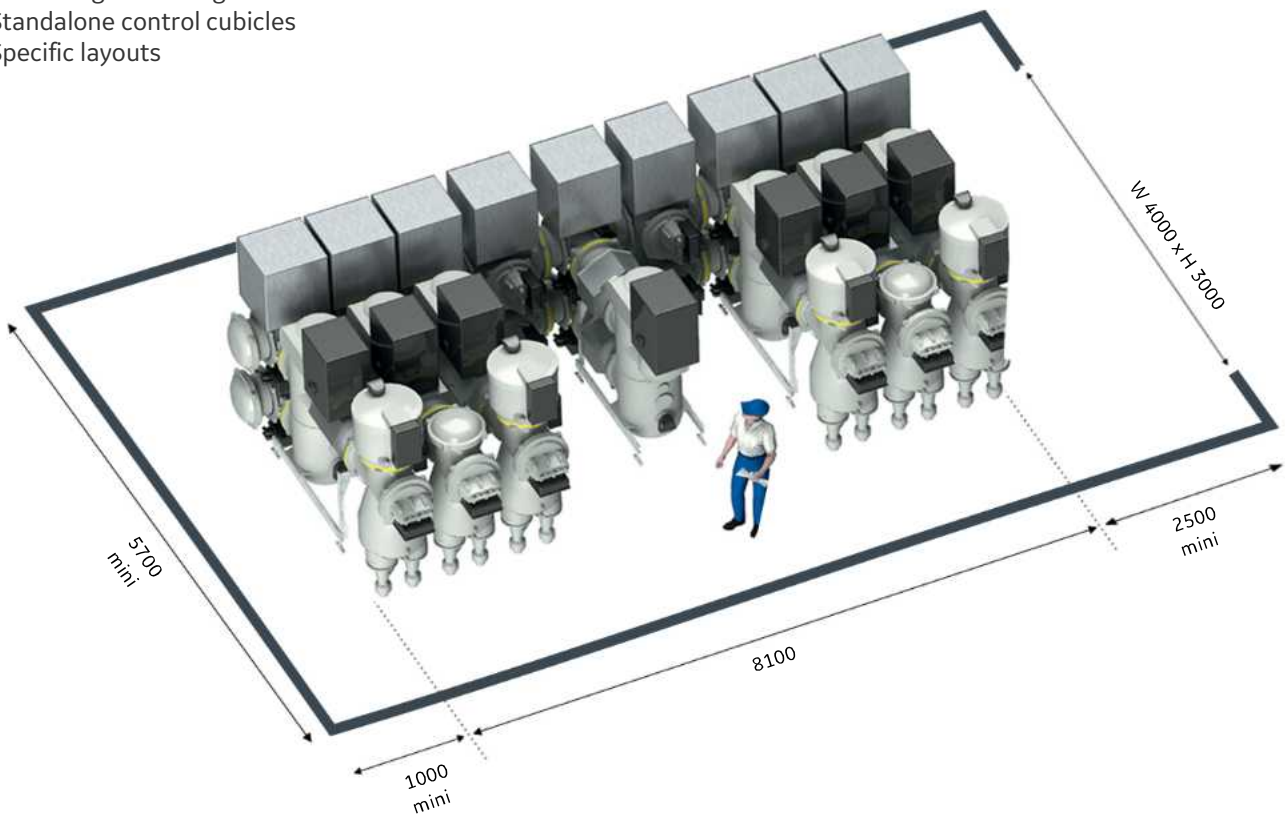

Available with SF<sub>6</sub> or g<sup>3</sup>

F35 Universal Bay: Always the same design whatever your choices

**Local Control Cubicle:**

Conventional or Digital, Embedded or Standalone  
 Can include a merging unit, voltage detection display, gas management interface, bay control unit including protections

**Circuit-breaker**

**Spring-drive:** single or three-pole operation  
 Optional : digitally controlled switching

**Combined voltage and current sensors:**  
 Conventional or digital. Available with additional conventional core for billing function

Optional **voltage detection** of incoming feeder

Combined **disconnector** and **earthing switch**

**Cable box**

**PDbox:**  
 Partial discharge monitoring

Single or double **busbar**

Busbar **disconnecter** and **earthing switch**

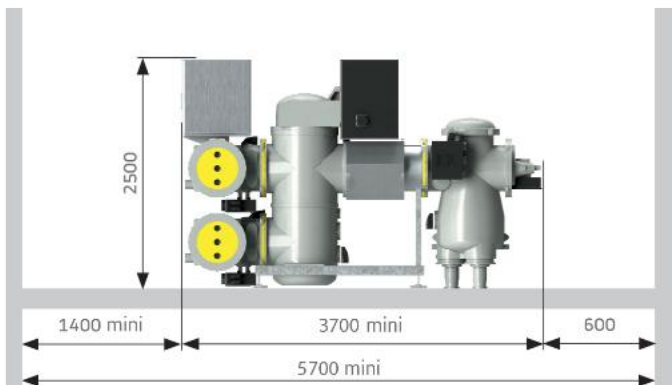
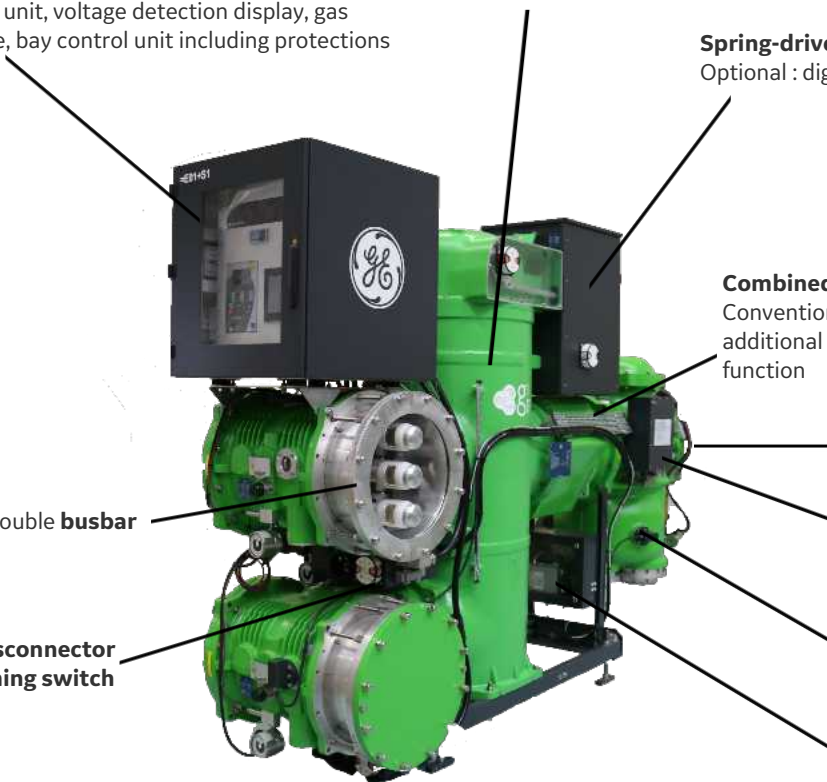

Digital Bay

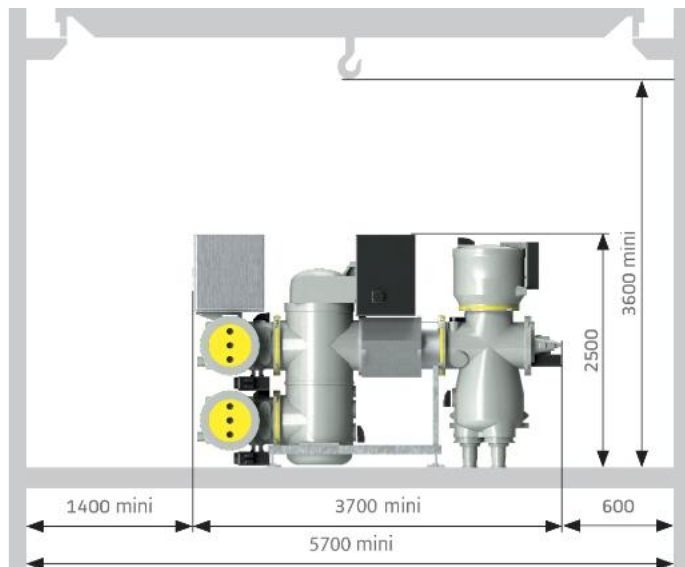

Conventional bay

**Always the same compact design, whatever the options**

### Low Power Instrument Transformers (LPIT)

Current and Voltage measurement on F35-GIS can be conventional and/or digital. With LPITs, the translation from primary to secondary measurement uses Rogowski or capacitive sensors, demonstrating a high level of accuracy, high immunity against electromagnetic perturbations (EMC), and high flexibility. The full digital components chain is available from sensors on the primary equipment to the control room, according to IEC 61869.

First LPITs on GE GIS have been in operation since 2005 in compliance with IEC 61850 protocol.

First g<sup>3</sup> GIS embedding LPIT energized in 2019.

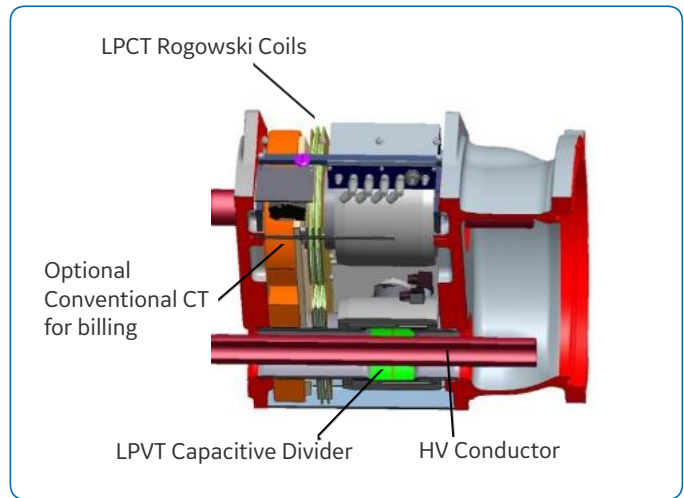

Combined Current and Voltage Transformer including an optional conventional core for billing function



Full Digital Components Chain

### Condition Monitoring - BWatch

BWatch is GE's solution for GIS digital condition monitoring. It uses the latest generation of EMC resistant digital gas sensors to continuously measure gas pressure and temperatures in order to track changes in density. And it enables to bring gas emissions down to 0.1% per year. It provides this information remotely and forecasts refilling needs prior to reaching threshold levels and affecting GIS operation.

**Main Functions:**

- Gas density monitoring and anticipation
- Gas temperature monitoring and alarms management
- Circuit-breaker and disconnecter monitoring
- Internal arc fault location
- Data analysis for optimized asset management

40,000 compartments are monitored with BWatch.

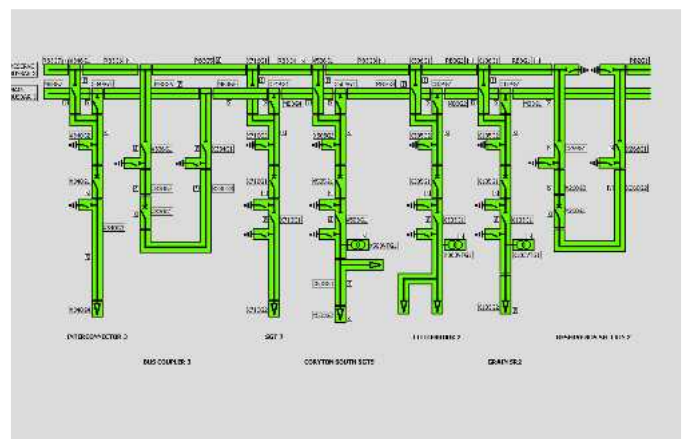

HMI supervision

## Partial Discharges Monitoring - PDWatch

When partial discharges occur, they generate electromagnetic waves that propagate throughout the switchgear. GE's PDWatch monitors these waves in the pressurized gas. It can be installed on F35-GIS and it monitors partial discharges via expert analysis of Ultra High Frequency (UHF) signals during commissioning, operation and maintenance.

Accuracy of data is secured thanks to band scanning, external noise discrimination, factory and site calibration of the system. The self-healing optical communication provides high reliability. Data interpretation is made easy for operating teams with a User-friendly HMI and expert tool.

Large field experience with 1,600 GIS bays equipped.

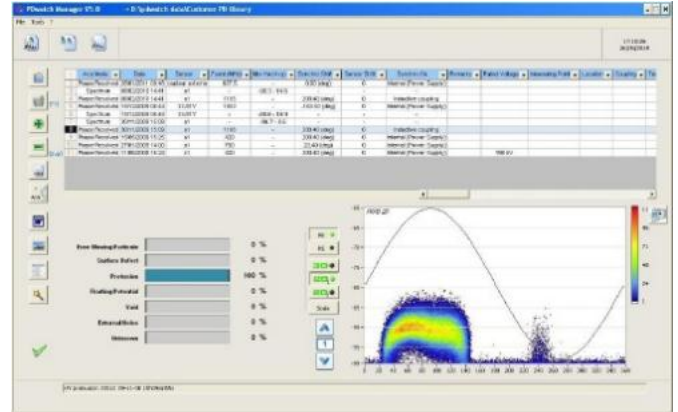

Time domain acquisition for pattern recognition with «PDWatch manager»

## Local Control Cubicle

**A full set of possibilities are available for F35's local control cubicle:**

- Embedded or standalone,
- Conventional or digital or a mix of both technologies.

**The advantages of digital control cubicle are numerous:**

- Reduced cabling
- Compact cubicle
- Late specification of requirements possible
- Bay Control Unit (BCU) offers flexible configuration capabilities, advanced communication and functionality
- Significant savings in installation costs
- Centralized maintenance

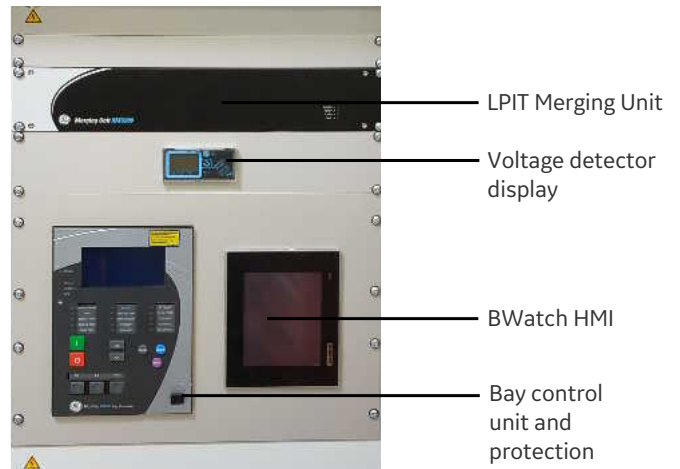

Digital Local Control Cubicle

## Controlled Switching - RPH

F35 can be equipped with digital controlled switching combined with a single-pole operated circuit-breaker.

Optimising the closing and opening of a circuit-breaker is of the utmost importance because random switching can result in high transient overvoltages and/or high inrush currents. These transients generate stresses on the substation and network equipment, leading to accelerated aging -or the worst case scenario- flashover of the HV apparatus.

Application	Target
Transmission lines	Reduce overvoltages (switching-on) Eliminate current zero missing
Power transformers	Eliminate inrush current (switching-on)
Shunt reactors	Eliminate current re-ignition (switching-off)
Capacitor banks	Eliminate inrush current (switching-on)

3,000 circuit-breakers are controlled with RPH, GE's controlled switching solution.

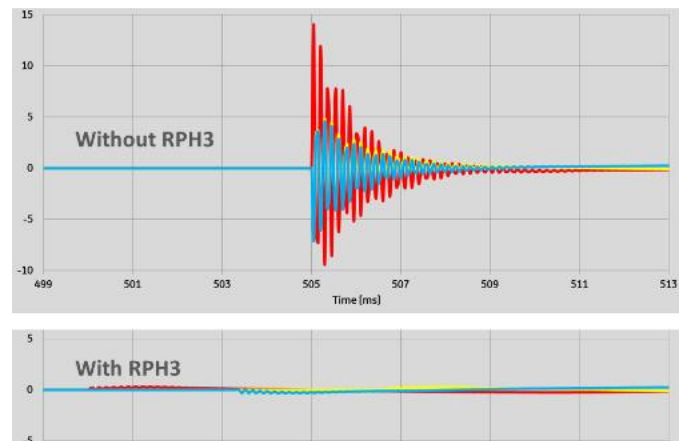

Inrush current limitation for shunt capacitor banks



	Conventional SF <sub>6</sub> bay	Conventional g <sup>3</sup> Bay	Fully Digital SF <sub>6</sub> Bay	Digital and Green Bay
<b>Gas</b>				
SF <sub>6</sub>	•		•	
g <sup>3</sup>		•		•
<b>Voltage and Current Measurement</b>				
Conventional Voltage and Current Transformers	•	•		
Digital current Transformer (LPIT)			○	○
Digital voltage Transformer (LPIT)			○	○
Combined digital current and voltage transformer (LPIT)			•	•
Billing conventional CT associated with LPIT			○	○
<b>Local control cubicle</b>				
Conventional interlock	•	•		
Digital interlock with Bay Control Unit			•	•
<b>Monitoring and Asset Management</b>				
Conventional density switch	•	•		
BWatch digital condition monitoring			•	•
PDWatch online			•	•
PDWatch portable			○	○
<b>Control</b>				
Three-pole operated circuit-breaker	•	•	•	•
Single-pole operated circuit-breaker	○	○	○	○
RPH controlled switching device	○	○	○	○
<b>Additional functions</b>				
Voltage detection on feeder when used of combined CT / VT	○	○	•	•
Surge arrester	○	○	○	○
Voltage Transformer Disconnecting links	○	○	○	○
<b>Bay Dimensions</b>				
Width x Depth x Height (mm)	800 x 3 700 x 2 500			

- Standard offering
- Optional

## Ratings

<b>General</b>		
Reference electrotechnical standards		IEC / IEEE
Voltage	kV	145
Withstand voltages		
Short-duration power-frequency, phase-to-earth / across isolating distance	kV	275 / 315
Lightning impulse, phase-to-earth / across isolating distance	kVp	650 / 750
Frequency	Hz	50 / 60
Continuous current	A	up to 3 150
Short-time withstand current	kA	40
Peak withstand current	kAp	100 / 108
Duration of short-circuit	s	3
Installation		indoor / outdoor
Ambient temperature range	°C	down to -30 / up to +55
<b>Circuit-Breaker</b>		
First-pole-to-clear factor		1.5
Short-circuit breaking current	kA	40
Short-circuit making current	kAp	100 / 108
Operating sequence		O – 0.3 s – CO – 3 min – CO / CO – 15 s – CO
Drive type (three-phase or single-phase)		pure-spring
Breaking time	ms	50
Closing time	ms	95
Mechanical endurance	class	M2
Capacitive switching	class	C2
<b>Disconnecter and Low-Speed Earthing Switch</b>		
Capacitive current switching	A	0.1
Bus-transfer current switching capability	A / V	1600 / 10
Mechanical endurance	class	M2
<b>Make-Proof Earthing Switch</b>		
Making current capability	kAp	100 / 108
Switching capability - electromagnetic coupling	A / kV	80 / 2
Switching capability - electrostatic coupling	A / kV	2 / 6
Mechanical endurance	class	M1

Other data available on request.

For more information please contact  
GE  
Grid Solutions

### **Worldwide Contact Center**

Web: [www.GEGridSolutions.com/contact](http://www.GEGridSolutions.com/contact)  
Phone: +44 (0) 1785 250 070

### **GEGridSolutions.com**

IEC is a registered trademark of Commission Electrotechnique Internationale.

GE, the GE monogram, g<sup>3</sup> and g<sup>3</sup> logo are trademarks of General Electric Company.

GE reserves the right to make changes to specifications of products described at any time without notice and without obligation to notify any person of such changes.

F35\_Universal-Brochure-EN-2019-05-1667-Grid-GIS. © Copyright 2019, General Electric Company. All Rights Reserved.

