

Multilin EPM 7000

Power Quality & Energy Cost Management

The Multilin™ EPM 7000 Power Quality meter provides revenue class (0.2%) three phase power metering with optional Ethernet, relay, status, and analog output communication modules. This flexible meter can be used for a wide range of high accuracy applications including disturbance recording and power quality studies.

The EPM 7000 is a highly accurate meter providing 0.1% accuracy for voltage and current. The unit's real-time clock provides time stamping of all logs as they are created. Up to 4MB of data can be logged for analysis of historical trends, limit alarms, I/O changes power quality recording and sequence of events.

Key Benefits

- Four Quadrant Energy and Power Measurement, complying with ANSI C12.20 (0.2%) accuracy
- Flexible mounting fitting both ANSI and DIN cutouts. DIN mount transducer (EPM 7000T) configuration for in-cabinet installation, reducing panel space requirements
- Analyze power quality over long periods of time to improve network reliability through high resolution event and disturbance recording
- Ideal for monitoring industrial power centers, data centers and hospitals due to high accuracy disturbance recording (up to 512 samples/cycle)
- Retrieve archived data, capture past events and analyze disturbances through high resolution data recording (up to 4MB of data logging)
- Flexible communications options including dual Ethernet provides simultaneous Modbus and IEC 61850 to provide easy to access meter values, simplified configuration and seamless integration into new or existing automation systems
- Upgradable through modular I/O and field upgradable firmware allowing the meter to be easily adapted for changing applications

Applications

- Four quadrant energy and power monitoring for feeders, transformers, reactors and generators
- Power monitoring of LV and MV industrial power systems and motor control centers
- Energy monitoring for commercial buildings and distribution utility applications
- Power Quality & Load Studies supported with data logging



Monitoring & Metering

- Meets ANSI C12.20 and IEC 687 (0.2% Accuracy)
- Current and Voltage measurements (Ia Ib Ic In, Va Vb Vc Vab Vbc Vca)
- Hz, W, VAR, VA, Wh, VARh, Vah
- Demand: W VAR VA and Power Factor
- Voltage and Current Angles, Load Bar
- Optional Transducer configuration without display (EPM 7000T)

Power Quality

- Harmonics to the 40th order & total harmonic distortion
- Disturbance recording and waveform capture
- Sag and Swell

Data Logging

- Up to 4MB of Memory
- 3 Assignable Historical logs (up to 64 parameters per log)
- System Events, Limit/Alarm Log, I/O Change Log
- Limits Alarms & Control Capability (option D and higher)

Communications

- IEC 61850
- Standard RS485 Serial Port (DNP 3.0 and Modbus RTU or ASCII)
- Optional 100BaseT Ethernet (Modbus/DNP or Modbus/IEC 61850)
- IrDA Port
- Intuitive faceplate programming

Software

- Embedded web server
- GE Communicator Software, EnerVista™ Integrator & LaunchPad

Overview

The EPM 7000 meter provides revenue class (0.2%) three phase power metering with optional Ethernet, relay, status, and analog output communication modules. This flexible meter can be used for a wide range of high accuracy applications including disturbance recording and power quality studies.

EPM 7000 can easily be mounted in a panel for generator monitoring, substation automation, power quality studies, data recording and more. The meter can also provide data to RTUs, PLCs and other control devices.

The EPM 7000 is a highly accurate meter providing 0.1% accuracy for Voltage and Current. The unit's real-time clock provides time stamping of all logs as they are created. Up to 4 MB of data can be logged for analysis of historical trends, limit alarms, I/O changes power quality recording and sequence of events.

Metering

The following electrical parameters are measured and remotely accessed from the EPM 7000.

Universal Voltage and Current Inputs

This meter allows voltage input measurements 20 Volts to 576 Volts Line to Neutral and up to 721 Volts Line to Line. This ensures proper meter safety when wiring directly to high voltage

systems. The unit will perform to specification on 69 Volt, 120 Volt, 230 Volt, 277 Volt and 347 Volt power systems.

Unique Current Input Connections

EPM 7000 meter uses two current input wiring methods.

- Method One - CT pass through: Directly pass the CT through the meter without any physical termination on the meter. This insures that the meter cannot be a point of failure on the CT circuit. This is preferable to utility users when sharing relay class CTs. No Burden is added to the secondary CT circuit.
- Method Two - Current "Gills": The meter additionally provides ultra-rugged termination pass through bars allowing the CT leads to be terminated on the meter. This also eliminates any possible point of failure at the meter. This method is also a preferred technique for ensuring relay class CT integrity does not get compromised. No terminal blocks are required and this stud based design ensures that CTs will not open under a fault condition.

Through an optional high speed Modbus communications interface, the meter can also provide data to RTUs, PLCs and other control devices at Baud rates ranging from 9600 baud to 57.6 kbaud.

Solid Construction with Mounting Versatility

The EPM 7000 has a rugged design for harsh environment. This is especially important in power generation, utility substation, and critical user applications. The structural and electrical design of this meter was developed based on the recommendations and approvals of many of our utility customers.

EPM 7000 can easily be mounted in a panel for generator monitoring, substation automation and more. The unique dual design combines ANSI and DIN mounting structure and allows easy installation for both new metering applications and retrofit of existing analog meters.

The unit mounts directly in an ANSI C39.1 (4" Round form) or an IEC 92 mm DIN square form.

Future Upgrade Packs

The EPM 7000 is equipped with a virtual firmware based switch that allows feature upgrades through communications even after installation. This allows you to optimize your metering investment. Begin with a standard meter and upgrade it with more functionality as new features are needed, such as data-logging, waveform capture or more memory.

Multifunction Metering & Power Quality Monitoring

The EPM 7000 can provide a total picture usage and power quality as different points within a power distribution network on critical infrastructure such as data centers, allowing users to make power related decisions quickly and effectively.

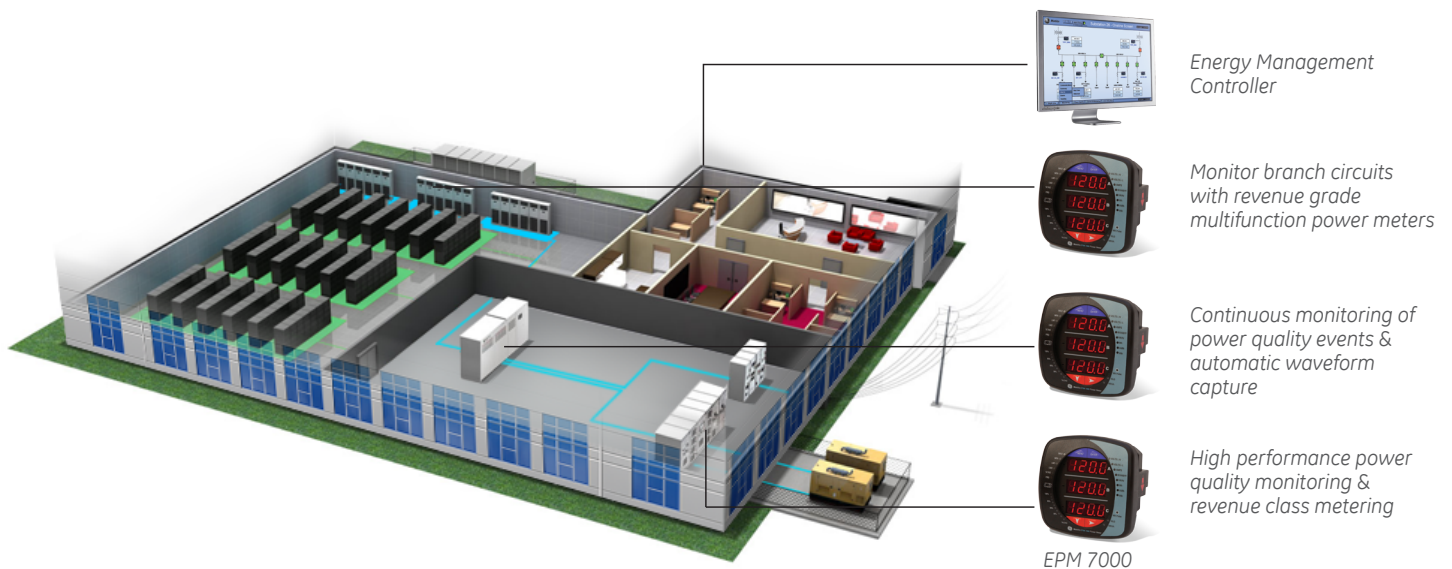

Current Input Connections

Method One

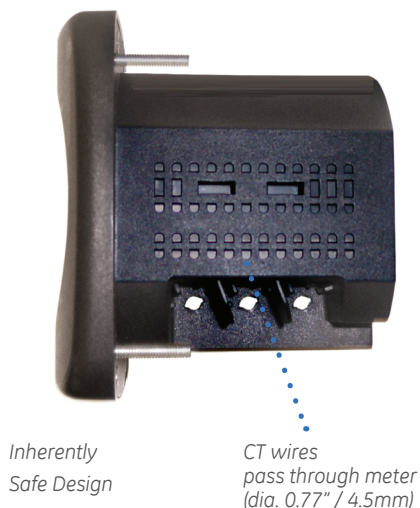

Inherently Safe Design

CT wires pass through meter (dia. 0.77" / 4.5mm)

Method Two

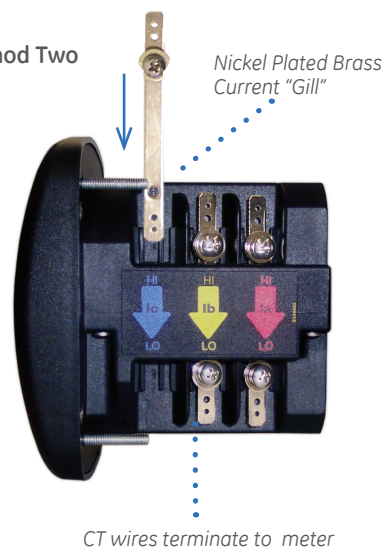

CT wires terminate to meter

Software Options

Software Option	Measured Values	Real-Time	Avg	Max	Min
A	Voltage L-N	•		•	•
	Voltage L-L	•		•	•
	Current Per Phase	•	•	•	•
	Current Neutral	•			
	% of Load Bar	•			
	Voltage Angles	•			
	Current Angles	•			
	Watts	•	•	•	•
	VAR	•	•	•	•
	VA	•	•	•	•
	PF	•	•	•	•
	Frequency	•			•
	+Watt-hr	•			
	-Watt-hr	•			
	Watt-hr Net	•			
	+VAR-hr	•			
	-VAR-hr	•			
	VAR-hr Net	•			
	VA-hr	•			
	B The above plus data-logging	2 MB Data-Logging	•		
C The above plus Harmonic Analysis	Harmonic Analysis	•			
D The above plus Limit and Control	Limit and Control Functions	•			
E The above plus Waveform Capture	Waveform Capture at 64 samples/cycle	•			
	3 MB total Data-Logging	•			
F The above plus Waveform Capture and Additional Memory	Waveform Capture at 512 samples/cycle	•			
	4 MB total Data-Logging	•			

Waveform Options

Software Option	Samples per cycle	Pre Event Cycles	Post Event Cycles	Max Waveform per Event	Number of Stored Events
E	16	32	96	256	85
	32	16	48	128	85
	64	8	24	64	85
F	128	4	12	32	170
	256	2	6	16	170
	512	1	3	8	170

Power Quality

The EPM 7000 can record voltage sag, swell, and current fault events. It records up to 512 samples per cycle, when events occur the meter will record pre and post event activity at a programmable sampling rate. Up to 4MB of storage is available allowing for a maximum of 170 events to be stored. Waveform data is stored in a circular buffer, this means that the meter is always recording.

Data Logging

The EPM 7000 meter offers the capability of having 2MB of date-logging to be used for historical trends, limit alarms, I/O changes power quality recording and sequence of events. The unit has a real-time clock that allows for time stamping of all the data in the instrument when log events are created.

Historical Logs:

- 3 Assignable Historical Logs
- Independently Program Trending
- Up to 64 Parameters per Log

System Events Log:

- Demand Resets
- Password Requests
- System Startup
- Energy Resets
- Log Resets & Reads
- Programmable Settings Changes

I/O Change Log:

- Times Stamped Log of any Relay Output
- Time Stamped Log of Input Status Changes
- 2048 possible events

Limit/Alarm Log

- Provides Magnitude and Duration of an Event
- Time Stamp and Alarm Value provided
- 2048 possible events

Limits Alarms and Control Capability (Option D and higher)

- Any measured parameter
- Up to 16 limits can be selected
- Voltage Imbalance
- Current Imbalance
- Based on percentage full scale settings

Communications

Front Mounted IrDA

All EPM 7000 meters come equipped with Front Mounted IrDA Communications port. This eliminates the need for a communications cable when the technician has an IrDA-equipped PC or a PDA with COPILOT EXT software. The meter can be set-up and programmed through the IrDA connection.

Rear Mounted Serial Port with KYZ Pulse

The RS485 serial interface supports Modbus, and DNP 3.0 at baud rates ranging from 9600 to 57.6K. Also supported are KYZ pulse outputs that are mapped to absolute energy

Expandable I/O and Communications Capabilities

EPM 7000 meters have two expansion slots used to accept new I/O cards. These slots can be equipped at the factory or in the field. The meter auto-detects installed I/O cards. Up to two cards of any type may be used per meter.

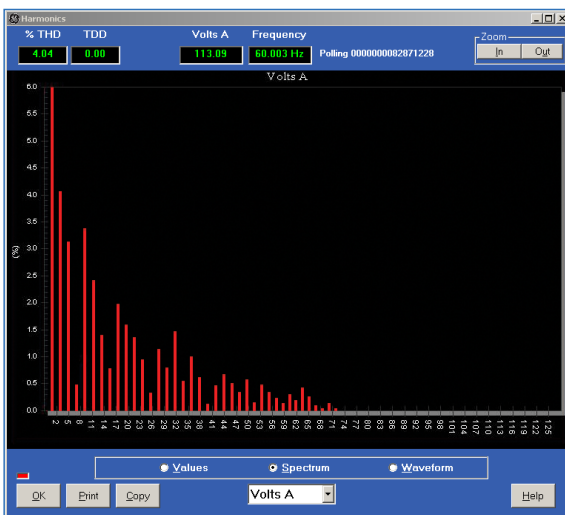

Harmonic Spectrum

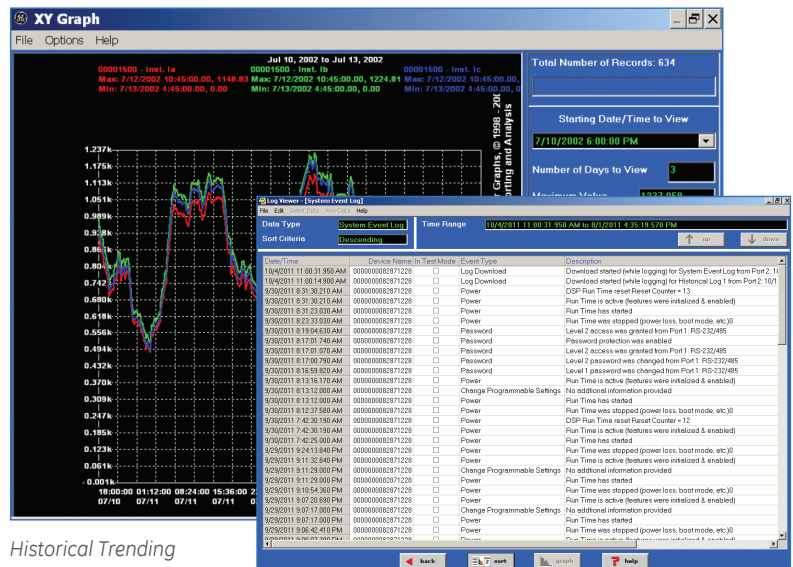

Historical Trending

Expandable I/O Cards

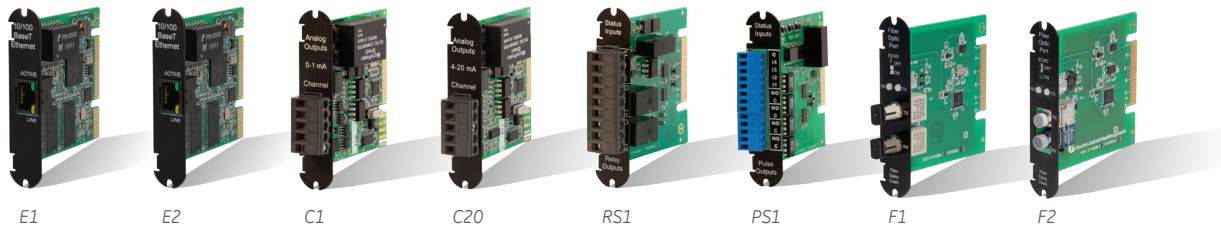

- E1:**
- 100BaseT Ethernet Card (Modbus, DNP)
 - 12 simultaneous Modbus TCP/IP connections
 - 5 simultaneous DNP over TCP/IP connections
 - Network Time Protocol (NTP) support (Network Clock Sync)
 - Embedded web server, Smartphone access compatible
 - Available support for dual Ethernet Ports available
- E2:**
- IEC 61850 Ethernet Card
 - Simultaneous Modbus and IEC 61850
 - IEC 61850 Support including:
 - Configurable .CID file
 - 5 Simultaneous MMS Clients
 - Multiple Logical Nodes
 - Polled Operation Mode (Queried Reports)
 - Buffered and Unbuffered Reports
- C1:**
- Four Channel Bi-directional 0-1mA Outputs
 - Assignable to any parameter
 - 0.1% of Full Scale
 - 0 to 10K Ω
 - Range $\pm 1.20\text{mA}$
- C20:**
- Four Channel 4-20mA Outputs
 - Assignable to any parameter
 - 0.1% of full scale
 - 0 – 500 Ω , no accuracy losses
 - Loop Powered up to 24VDC
- RS1:**
- Two Output Relays/ Two Status Inputs
 - 250VAC/30VDC – 5A Relays, Form C
 - Trigger on user set alarms
 - Set delays and reset delays
 - Status Inputs – Wet/Dry Auto Detect (Up to 150VDC)
 - Requires Software Option D or higher for limit based alarms and control
- PS1:**
- Four Pulse Outputs / Four Status Inputs
 - Programmable to any energy parameter and pulse value
 - Normally Open Contacts, Form A
 - 120mA continuous load current
 - Status Inputs – Wet/Dry Auto Detect (Up to 150VDC)
 - Can function for manual relay control and limit based control
 - Requires Software options D or higher for limit based alarms and control
- F1:**
- Fiber Optic Interface with ST terminations
 - Daisy Chain switchable built-in logic mimics RS485 half duplex bus
 - ST terminated
 - Modbus and DNP 3.0 Protocols available
- F2:**
- Fiber Optic Interface with Versatile terminations
 - Daisy Chain switchable built-in logic mimics RS485 half duplex bus.
 - Versatile terminated
 - Modbus and DNP 3.0 Protocols available

Embedded Web

The EPM 7000 with Ethernet (E1,E2 options) includes a secure web server that is viewable from a variety of web browsers. The web server supports multiple simultaneous connections to view the following information:

- Voltage and Current Reading
- Power and Energy Readings
- Power Quantity Information
- General Meter Information

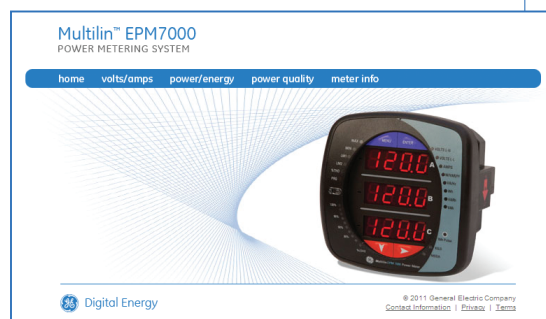

Simultaneous Data Connection through Ethernet and Web Server

Multilin™ EPM7000
POWER METERING SYSTEM

home volts/amps power/energy power quality meter info

volts/amps

Meter Status SubPanel2 Date/Time: 2011-09-30 13:09:03

Voltage/Frequency			
	Instantaneous	Maximum	Minimum
Volts AB	113.454	113.647	0.000
Volts AB	113.523	113.676	0.000
Volts CB	0.000	19.900	0.000
Volts A-B	0.000	2.194	0.000
Volts B-C	113.550	113.652	0.000
Volts C-A	113.525	113.623	0.000
Frequency	59.98	60.02	0.00

Current			
	Instantaneous	Maximum	Minimum
Amps A	0.000	0.000	***
Amps B	0.000	0.000	***
Amps C	0.000	0.000	***
Amps N (calculated)	0.000	0.000	***

Digital Energy © 2011 General Electric Company
Contact Information | Privacy | Terms

Simultaneous Data Connections

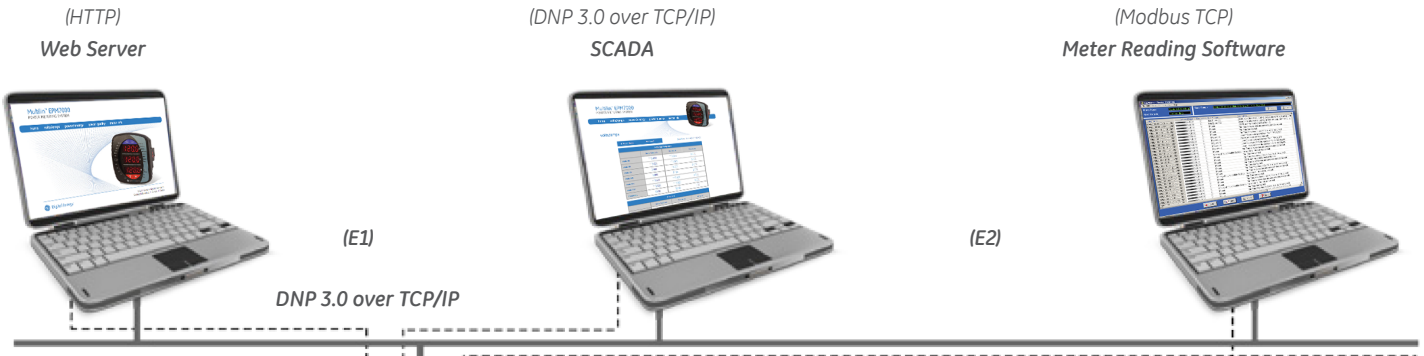

Simultaneous Connections to Multiple Software Systems



E1 - Web Server, Modbus, DNP

- 100BaseT Ethernet Card (Modbus, DNP)
- 12 simultaneous Modbus TCP/IP connections
- 5 simultaneous DNP over TCP/IP connections
- Network Time Protocol (NTP) support (Network Clock Sync)
- Embedded web server, Smartphone access compatible
- Available support for dual Ethernet Ports available

E2 - Web Server, Modbus, IEC 61850

- IEC 61850 Ethernet Card
- Simultaneous Modbus and IEC 61850
- IEC 61850 Support including:
 - Configurable .CID file
 - 5 Simultaneous MMS Clients
 - Multiple Logical Nodes
 - Polled Operation Mode (Queried Reports)
 - Buffered and Unbuffered Reports

Embedded Web Server with Smartphone Support

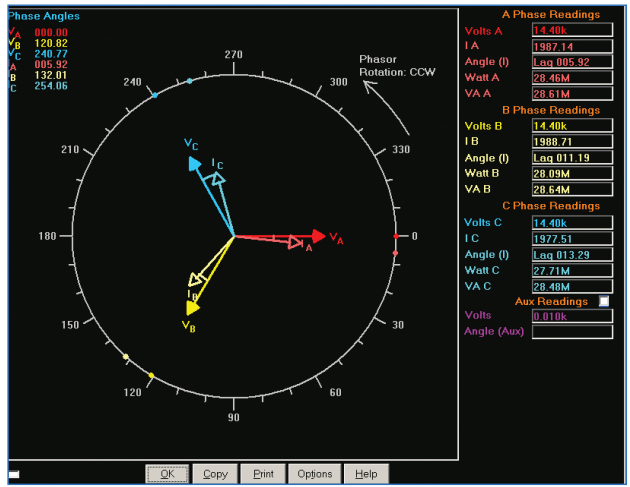

GE Communicator Software - Phasor Demo Mode

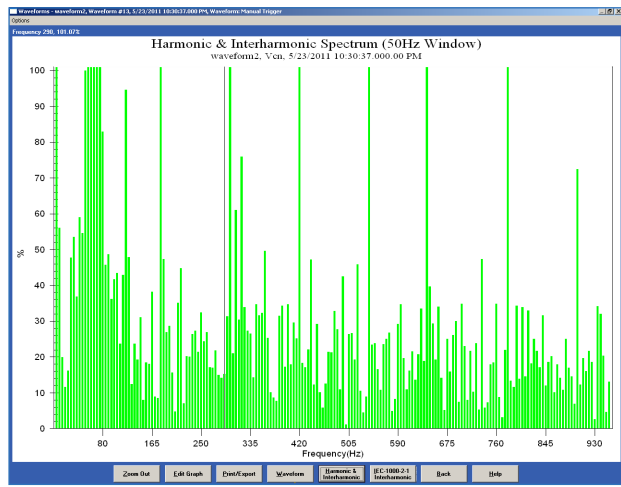

GE Communicator Software - Harmonic and Interharmonic Spectrum

Software

GE Communicator Software

This software connects remote meters via Serial, Ethernet or Modem. It allows users to view real time metered data, configure and analyze collected information from remote EI power monitors. It works with the EPM 2200, EPM 6000, EPM 7000, EPM 9450, EPM 9650 and EPM 9800 meters.

GE Communicator displays real time data from supported meters. The data is presented in a simple and powerful graphical format so that laymen access data easily. The software offers many screens, including:

- Voltage, Current, Power & Energy
- Time of Usage & Accumulations
- Power Quality
- Harmonics to the 255th Order
- Actual Real time Waveform Scopes
- Alarms & Limits
- Max. & Min. for Each Parameter
- I/O Device Information

EnerVista™ Launchpad

EnerVista™ Launchpad is a powerful software package that provides users a platform to access all of the setup and support tools needed for configuring and maintaining GE Multilin Products. Launchpad allows configuration of devices in real-time by communicating using

RS232, RS485, Ethernet, or modem connections. Using Launchpad as the single interface to the setup and analysis software makes it simple to enter set points, read metered values, monitor status and evaluate power quality.

Included in Launchpad is a document archiving and management system that ensures critical documentation is up-to-date and available when needed by automatically checking for and downloading new versions of manuals, applications notes, specifications, and service bulletins.

EnerVista™ Integrator

EnerVista™ Integrator is a toolkit that allows seamless integration of GE Multilin devices into new or existing automation systems by sending GE device data to HMI, DCS, and SCADA systems. Included in EnerVista™ Integrator is:

- OPC/DDE Server
- GE Multilin Drivers
- Automatic Event Retrieval
- Automatic Waveform Retrieval

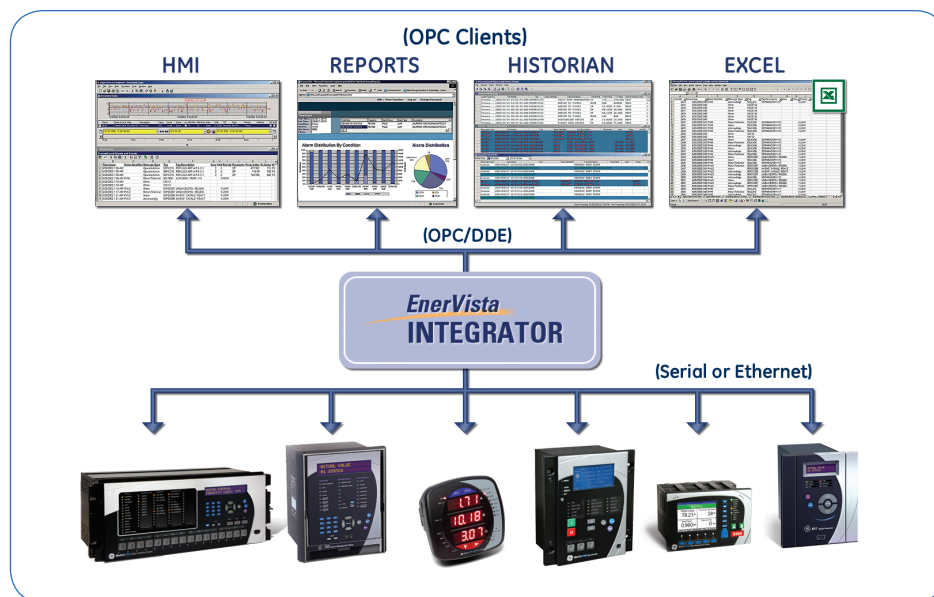

Multilin Meter Enclosure

Expanding existing switchgear or installing new metering capability can be challenging due to space limitations, downtime and installation and equipment costs. GE's Multilin Meter Enclosure is a pre-wired configured, economical solution for both retrofit expansions and small scale meter installations that allows the expansion of existing switchgear capability without expensive and time-consuming design.

When ordered as a meter option the enclosure provides a factory pre-wired, installation-ready metering solution that further drives energy cost savings, by enabling the measurement of key energy usage information along multiple metering points for new or existing systems.

Ordering the enclosure is simple when selected as an option during meter configuration, ensuring correct pre-wired meter-compatible delivery.

Pre-Wired, Configured and Economical Solution for Retrofit and Small Metering Systems

Easy and Rapid Installation

- Factory pre-wired, installation-ready GE metering solution eliminates wiring and associated errors for rapid installation
- Extend metering capability with new systems and existing switchgear without system installation downtime

Cost-Effective Retrofit Solution

- Save up to 200% versus the addition of a new switchgear cabinet
- Compact footprint makes effective use of existing allocated space
- Allows new installations or the expansion of existing switchgear capability without expensive, time-consuming designs, eliminating system downtime

Reliable and Compatible

- Backed by a 10 year warranty
- Simple meter option ordering ensures compatibility with GE EPM 2000/6010/6000/7000 meters
- Comprehensive factory testing of both meter and enclosure together
- NEMA1 tested and UL/CUL certified

Applications (New and Retrofit installations)

- Industrial Multi-Tenant Monitoring
- Commercial/Residential Buildings
- Healthcare Institutions
- Government Buildings
- Manufacturing
- Educational Campuses



Assembly

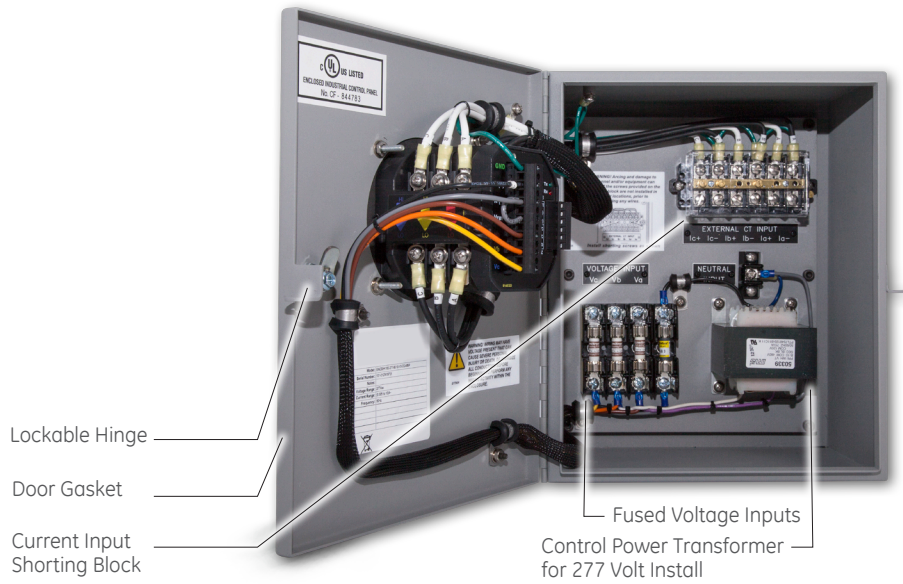

Dimensional Drawings

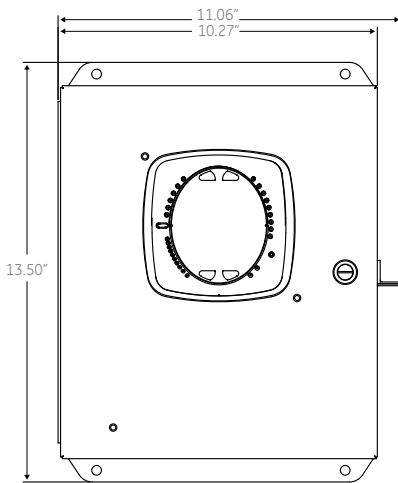

Enclosure Front Dimensions

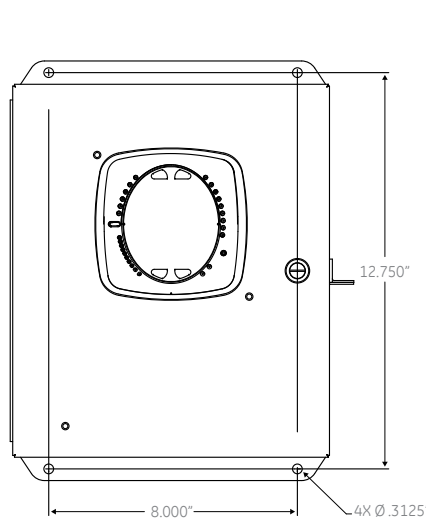

Mounting Hole Dimensions

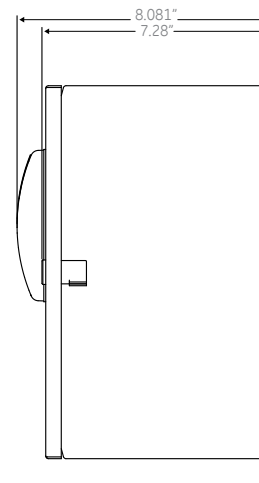

Enclosure Side Dimensions

Dimensions and Mounting

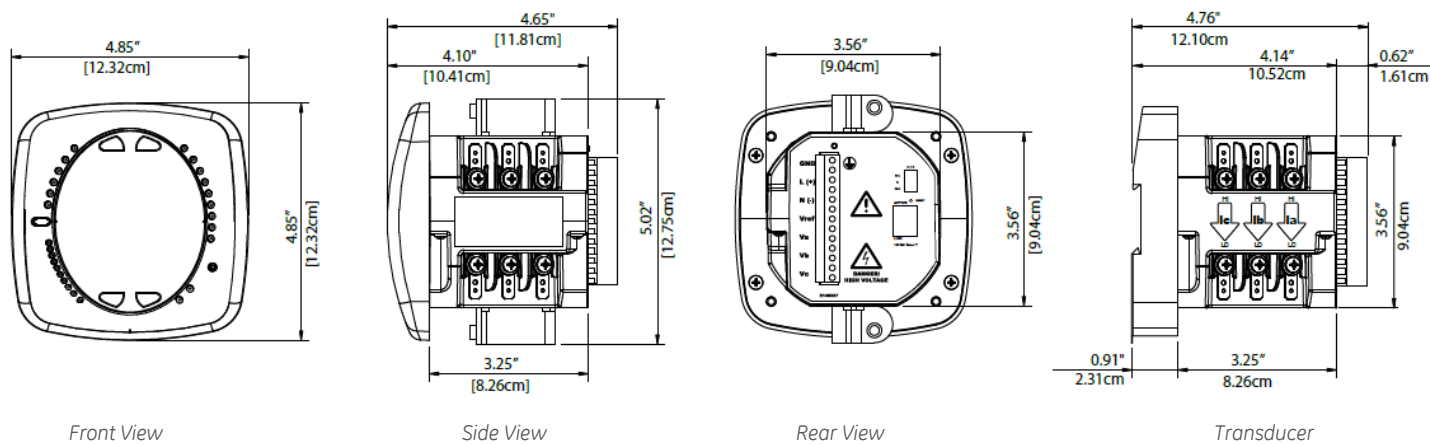

User Interface



Technical Specifications

VOLTAGE INPUTS

- 20-576 Volts Line to Neutral
- 0-721 Volts Line to Line
- Universal Voltage Input
- Input Withstand Capability – Meets IEEE C37.90.1 (Surge Withstand Capability)
- Programmable Voltage range to any PT ratio
- Supports: 3 Element WYE, 2.5 Element WYE, 2 Element Delta, 4 Wire Delta Systems
- Burden: 0.014W at 120 Volts
- Input Wire Gauge Max (AWG 12 / 2.5 mm²)

CURRENT INPUTS

- Class 10: (0.005 to 11)A, 5 Amp Nominal
- Class 2: (0.001 to 2)A, 1A Nominal Secondary
- Fault Current Withstand:
 - 100 Amps for 10 Seconds
 - 300 Amps for 3 Seconds
 - 500 Amps for 1 Second
- Continuous current withstand:
 - 20A for Screw Terminated or Pass Through Current Connections
- Programmable Current to Any CT Ratio
- Burden 0.005VA Per Phase
- Max at 11 Amps
- Pickup Current:
 - 0.1% of Nominal
 - Class 10: 5mA
 - Class 2: 1mA
- Pass Through Wire Gauge Dimension: 0.177" / 4.5mm

ISOLATION

- All Inputs and Outputs are Galvanically Isolated to 2500 Volts AC

SENSING METHOD

- True RMS
- Sampling at 400+ Samples per Cycle on all channels measured readings simultaneously
- Waveform up to 512 Samples/cycle
- Harmonics resolution to 40th order

UPDATE RATE

- Watts, VAR and VA-100msec
- All other parameters 1sec

POWER SUPPLY

- HI : 90-265VAC and 100-370VDC
- LDC Option: 18-60VDC (24-48VDC Systems)

STANDARD COMMUNICATIONS

- 2 Com Ports (Back and Faceplate)
- RS485 Communications Port
- Through Backplate
- Protocol Modbus RTU or ASCII
- Com Port Baud Rate: 9600 to 57.6K
- Com Port Addresses: 001-247
- 8 Bit, No Parity
- IrDA
 - Through Faceplate
- Modbus RTU, ASCII or DNP 3.0, IEC 61850 Protocols

METERING ACCURACY

Measured Parameters	Accuracy% of Reading	Display Range
Voltage L-N	0.1%	0-9999 V or kV
Voltage L-L	0.2%	0-9999 Scalable V or kV
Current	0.1%	0-9999 Amps or kAmps
+/- Watts Mwatts	0.2%	0-9999 Watts, kWatts,
+/- Wh	0.2%	5-8 Digits Programmable
+/-VARs MVARs	0.2%	0-9999 VARs, kVARs,
+/-VARh	0.2%	5-8 Digits Programmable
VA	0.2%	0-9999 VA, kVA, MVA
VAh	0.2%	5 -8 Digits Programmable
PF	0.2%	+/- 0.5 - 1.0
Frequency	+/- 0.03 Hz	45 -65 Hz
%THD	+/- 2.0%	1 to 99.99%
% Load Bar	+/- 1 Segment	(0.005 to 6) A

KVZ PULSE

- Type Form C Contact
- On Resistance: 35Ω Max
- Peak Voltage: 350VDC
- Continuous Load Current: 120mA
- Peak Load Current: 350mA (10ms)
- Off State Leakage Current @ 350VDC: 1μA

DIMENSIONS & SHIPPING

- Weight: 2lbs
- Basic Unit: H4.85x W4.82 xL4.25 inches
- Mounts in 92mm Square DIN or ANSI C39.1 Round Cut-outs
- Shipping Container Dimensions: 6" cube

ENVIRONMENTAL

Storage: -20° C to +70° C
 Operating: -20° C to +70° C
 Humidity: to 95% RH Non-Condensing
 Faceplate Rating: NEMA12 (Water Resistant) Mounting Gasket Included

COMPLIANCE

- IEC 687 (0.2% Accuracy)
- ANSI C12.20 (0.2% Accuracy)
- ANSI (IEEE) C37.90.1 Surge Withstand
- ANSI C62.41 (Burst)
- IEC1000-4-2: ESD
- IEC1000-4-3: Radiated Immunity
- IEC1000-4-4: Fast Transient

APPROVALS

ISO: Manufactured to an ISO9001 registered program
 UL: Listed under E250818
 CE: Conforms to European CE standards

Ordering

PL7000	*	*	*	*	*	*	*	Description
Enclosure	ENC120 ENC277 XXXXXX							Standard unit with display, all current/voltage/power/frequency/energy counters measurement, % load bar, RS 485 and IRDA communication ports and one front test pulse output. NEMA1 Rated - Indoor, Single Meter Enclosure, 120V NEMA1 Rated - Indoor, Single Meter Enclosure, 277V Without Enclosure
Frequency		5 6						50 Hz AC frequency system 60 Hz AC frequency system
Current Inputs			5A 1A					5 Amps 1 Amp
Software				A B C D E F				Multimeter Function Only Data Logging Memory, 2 MB of Memory Power Quality Harmonics, 2 MB of Memory Limits and Control, 2 MB of Memory 64 Samples/Cycle Waveform Recording, 3 MB of Memory 512 Samples/Cycle Waveform Recording, 4 MB of Memory
Power Supply					HI LDC			90-265VAC/100-370VDC 18-60VDC
I/O Modules*						X E1 E2 C1 C20 RS1 PS1 F1 F2	X E1 E2 C1 C20 RS1 PS1 F1 F2	None 100BaseT Ethernet 100BaseT Ethernet with IEC 61850 Protocol Four Channel Bi-directional 0-1mA Outputs Four Channel 4-20mA Outputs Two Relay status Outputs / Two Status Inputs Four Pulse Outputs / Four Status Inputs Fiber Optic Interface with ST terminations Fiber Optic Interface with Versatile Terminations

* Each I/O module can be ordered as a separate upgradable part

EPM 7000 is available without a display as the EPM 7000T. Please see the online store for ordering information.



imagination at work

GE
650 Markland St.
Markham, ON
Canada L6C 0M1

Toll Free (NA Only): 1-800-547-8629

Tel: 905-927-7070

Fax: 905-927-5098

GEGridSolutions.com

IEC is a registered trademark of Commission Electrotechnique Internationale. IEEE is a registered trademark of the Institute of Electrical Electronics Engineers, Inc. Modbus is a registered trademark of Schneider Automation. NERC is a registered trademark of North American Electric Reliability Council. NIST is a registered trademark of the National Institute of Standards and Technology.

GE, the GE monogram, Multilin, FlexLogic, EnerVista and CyberSentry are trademarks of General Electric Company.

GE reserves the right to make changes to specifications of products described at any time without notice and without obligation to notify any person of such changes.

Copyright 2016, General Electric Company. All Rights Reserved.

GEA-12822A(E)
English
160315