

Multilin™ EPM 6100

Energy and Demand Submeter with Wi-Fi

The EPM 6100 is a powerful tool that allows customers to monitor and manage their energy usage within factories, businesses and across campuses. The EPM 6100 is a multifunction meter that features ANSI C12.20 (0.2% class) accuracy and RS485, RJ45 Ethernet or IEEE 802.11 WiFi communication connections, making the meter easy to deploy in modern and older communications systems.

Key Benefits

- Flexible WiFi option eliminates the need for expensive wiring
- 0.2% accurate revenue class meter provides highly reliable measurements
- Multifunction capability allows for a variety of voltage, current, and energy metering measurements
- Direct interface with most building management systems reduces integration costs
- Easy installation reduces setup time and costs
- Energy monitoring to increase OEMs efficiency

Applications

- Allocate energy usage throughout multi-tenant settings, such as industrial and university campuses, office towers, apartment complexes and shopping centers
- Submetering in Government, military and airport facilities



Monitoring & Metering

- Current: Ia Ib Ic In
- Voltage: Va Vb Vc Vab Vbc Vca
- Frequency: Hz W VAR VA
- Reactive Power: Wh VARh Vah
- Demand: W VAR VA
- Power Factor
- Voltage and Current Angles
- Bright Red LED Display with Three .56" Lines
- % of Load Bar for Analog Meter Perception

Communications

- Standard RS485 Modbus (Modbus RTU or ASCII)
- IrDA Port
- Optional Ethernet 10.100BaseT or WiFi
- Intuitive Faceplate Programming



Overview

The EPM 6100 is a powerful tool that allows customers to monitor and manage their energy usage within factories, businesses and across campuses. The EPM 6100 is a multifunction meter that features ANSI C12.20 (0.2% class) accuracy and RS485, RJ45 Ethernet or IEEE 802.11 WiFi communication connections, making the meter easy to deploy in modern and older communications systems. Early detection of power problems is facilitated through THD and the alarming capabilities of the EPM 6100. The units use standard 5 or 1 amp CTs (either split or donut), surface mount to any wall and are easily programmed in minutes.

Monitoring and Metering

Traceable Watt-Hour Test Pulse for Accuracy Certification

To be certified for revenue metering, power providers and utility companies need to know that the billing energy meter will perform to its stated accuracy. To verify the meter's performance and calibration, power providers use field test standards to ensure that the unit's energy measurements are correct. Since

the EPM 6100 submeters are traceable revenue meters, they contain a utility grade test pulse allowing power providers to verify and confirm that the meters are performing to their rated accuracy. This is an essential feature required in all billing grade meters.

Utility Peak Demand Metering

EPM 6100 submeters provide user-configured Block Window or Rolling Window Demand. This allows customers to set up a particular utility demand profile. Block Window Demand is demand used over a fixed user-configured demand period (usually 5, 15 or 30 minutes). Rolling Window Demand is a fixed window demand that moves for a user specified sub-interval period. An example is a 15 minute demand using 3 subintervals, providing a new demand reading every 5 minutes based on the last 15 minutes. Readings for kW, kVAR, kVA and PF are calculated using utility demand structures. Other parameters offer max and min capability over the user-selectable averaging period. Voltage provides a non-rolling instantaneous max and min reading, displaying the highest surge and lowest sag seen by the meter.

Communications

Standard Modbus RS485 Communication

Standard communication includes an RS485 output speaking Modbus protocol. This allows the unit to be connected to any serial RS485 bus using the Modbus interface. The unit communicates easily with most building automation or other software systems. Baud rates are up to 57.6K baud to provide fast update times.

WiFi or LAN-Based Ethernet

The unit offers two Ethernet options — either an RJ45 or WiFi connection. The WiFi option allows the EPM 6100 submeter to be used on standard WiFi base stations.

IrDA Port

Use an IrDA-equipped laptop PC to program and read the EPM 6100 submeter.

KYZ Pulse

For applications in which a pulse is needed, the unit also provides a KYZ output which pulses proportional to the amount of energy consumed. This feature is used for pulse counting applications or for building management systems where serial or Ethernet protocol is not available.

Shopping Mall or Commercial Application of EPM 6100

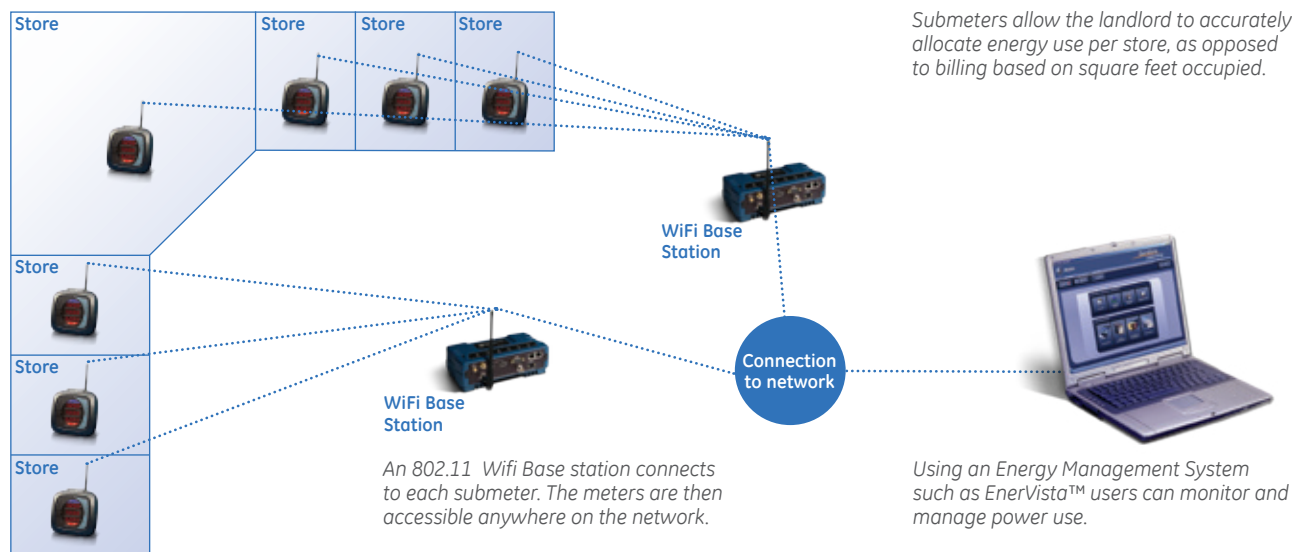

EPM 6100 Deployed within an Office Tower

EPM 6100 meters deployed within an office tower to monitor individual tenants. EPM 6100 can be deployed in buildings with multiple tenants to accurately allocate energy costs to specific leases or circuits.

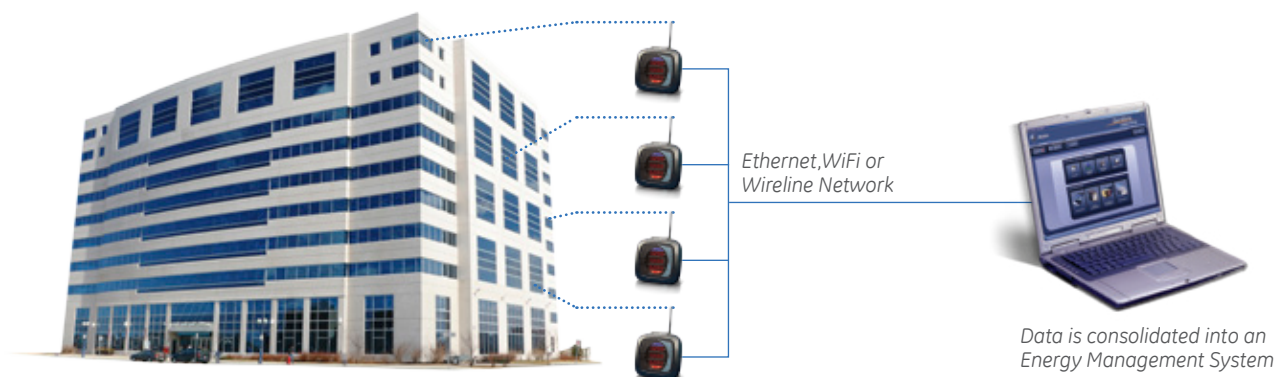

EnerVista™ Software

EnerVista Launchpad

EnerVista Launchpad is a powerful software package that provides users a platform to access all of the setup and support tools needed for configuring and maintaining GE Multilin products.

EnerVista Launchpad allows configuration of devices in real-time by communicating using RS232, RS485, Ethernet or modem connections. Using Launchpad as the single interface to the setup and analysis software makes it easy to enter set points, read metered values, monitor status and evaluate power quality.

Included in EnerVista Launchpad is a document archiving and management system that ensures critical documentation is up-to-date and available when needed by automatically checking for and downloading new versions of manuals, applications notes, specifications and service bulletins.

EnerVista Integrator

EnerVista Integrator is a toolkit that allows seamless integration of GE Multilin devices into new or existing automation systems by sending GE device data to HMI, DCS and SCADA systems. Included in EnerVista Integrator is:

- OPC/DDE Server
- GE Multilin Drivers
- Automatic Event Retrieval
- Automatic Waveform Retrieval

EPM 6100 Accuracy

MEASURED VALUES	ACCURACY
Voltage L-N	0.1% of Reading
Voltage L-L	0.1% of Reading
Current	0.1% of Reading
+/- Watts	0.2% of Reading
+/- Wh	0.2% of Reading
+/- VARs	0.2% of Reading
+/- VARh	0.2% of Reading
VA	0.2% of Reading
VAh	0.2% of Reading
PF	0.2% of Reading
Frequency	0.03Hz
%THD	5.0 %
Load Bar	+/- 1 Segment

Measured Values

The EPM 6100 measures the following values:

MEASURED VALUES	REAL-TIME	AVG	MAX	MIN
Voltage L-N	•		•	•
Voltage L-L	•		•	•
Current Per Phase		•	•	•
Current Neutral	•			
Watts	•	•	•	•
VAR	•	•	•	•
VA	•	•	•	•
PF	•	•	•	•
+Watt-Hr	•			
-Watt-Hr	•			
Watt-Hr Net	•			
+VAR-Hr	•			
-VAR-Hr	•			
VA-Hr	•			
Frequency	•		•	•
%THD	•		•	•
Voltage Angles	•			
Current Angles	•			
% of Load Bar	•			

Dimensions and Mounting

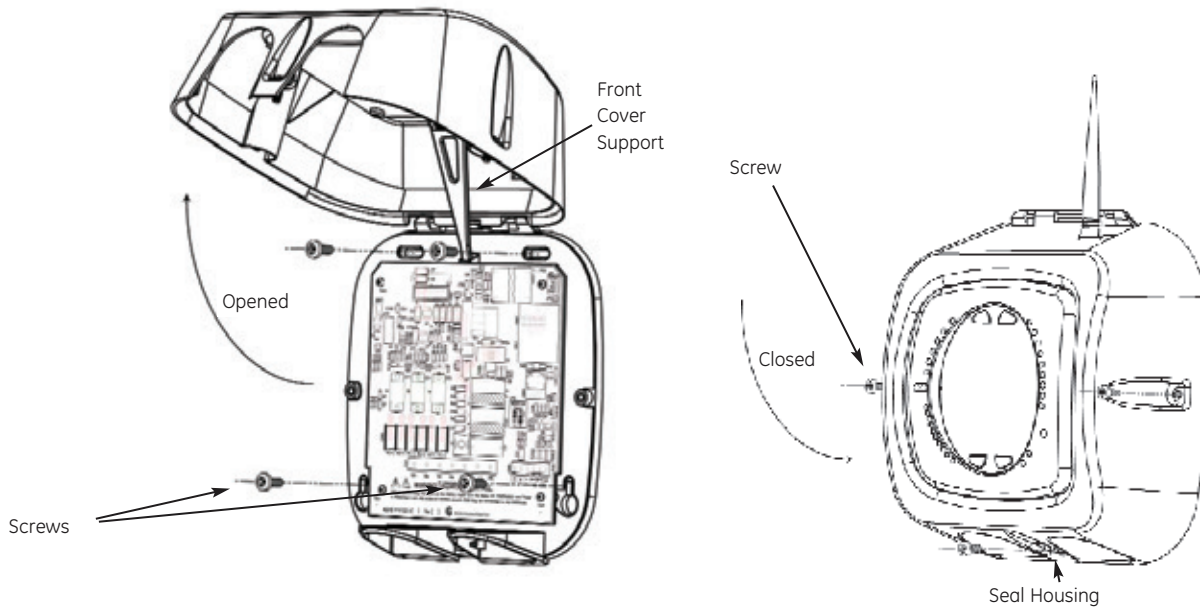
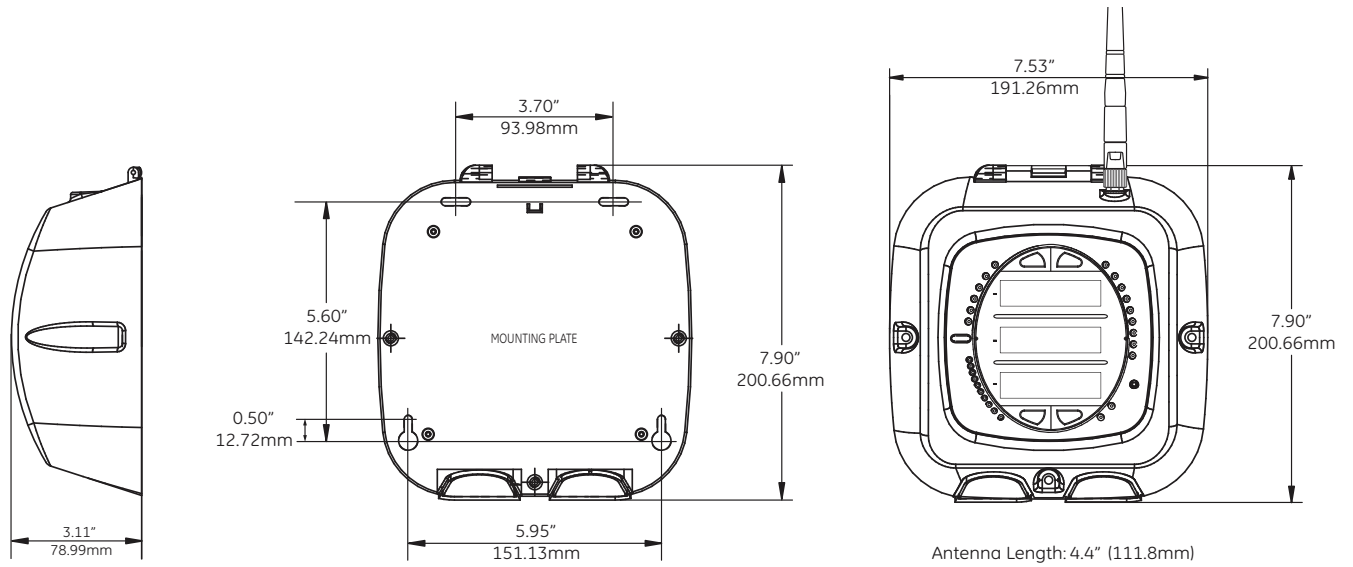

User Interface

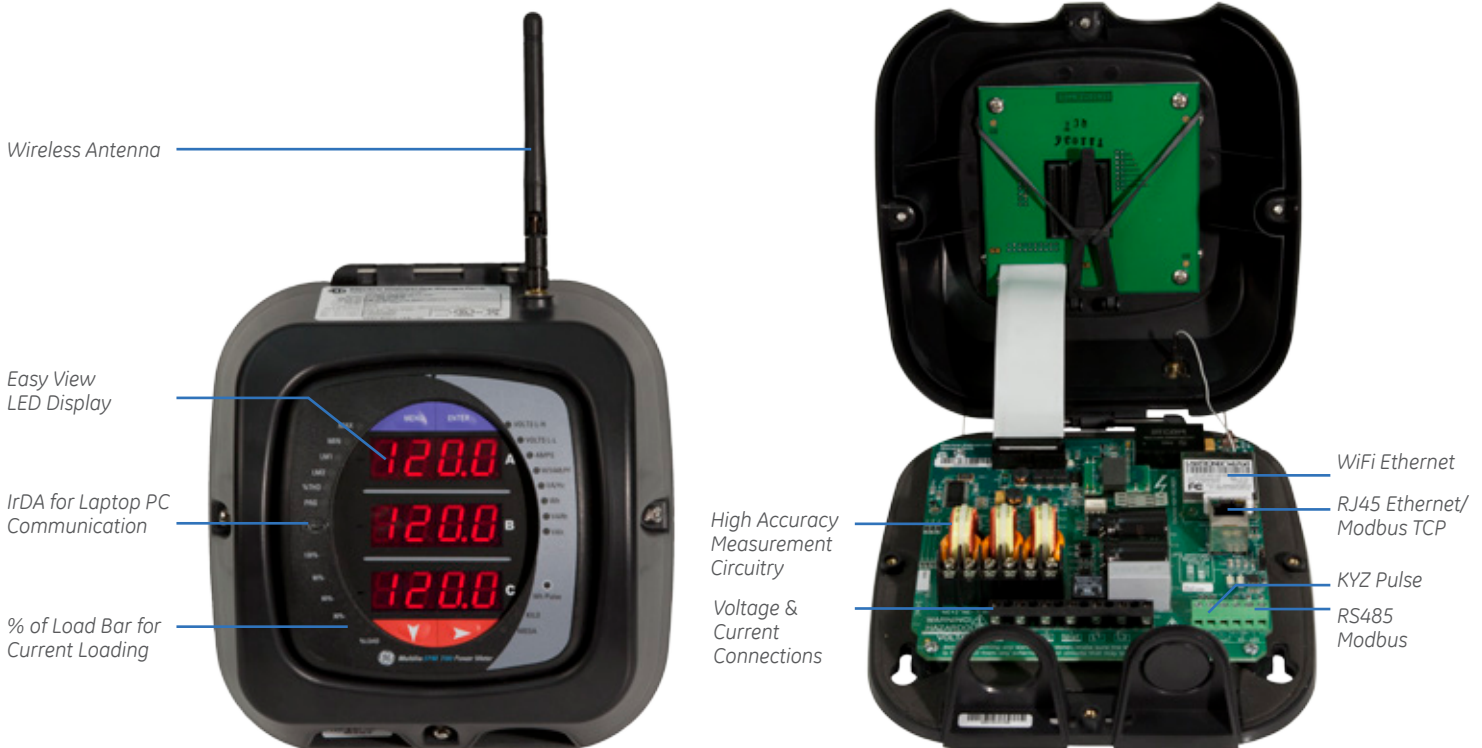

Technical Specifications

VOLTAGE INPUTS

- 20-576 Volts Line to Neutral
- 0-721 Volts Line to Line
- Universal Voltage Input
- Input Withstand Capability – Meets IEEE C37.90.1 (Surge Withstand Capability)
- Programmable Voltage Range to Any PT Ratio
- Supports: 3 Element WYE, 2.5 Element WYE, 2 Element Delta, 4 Wire Delta Systems
- Burden: 0.36VA per Phase Max at 600V, 0.014VA at 120 Volts

CURRENT INPUTS

- Class 10: 5 Amp Nominal, 10 Amp Maximum
- Class 2: 1 Amp Nominal, 2 Amp Secondary
- Programmable Current to Any CT Ratio
- Burden 0.005VA per Phase Max at 11Amps
- 5mA Pickup Current for Class 10
- 1mA Pickup Current for Class 2
- Current Surge Withstand: 100A/10 Seconds at 23°C

ISOLATION

- All Inputs and Outputs are galvanically isolated to 2500 Volts AC

ENVIRONMENTAL RATING

- Storage: -20 to +70°C
- Operating: -20 to +70°C
- Humidity: to 95% RH (Non-condensing)

SENSING METHOD

- RMS
- Sampling at 400+ Samples per cycle on all channels measured readings simultaneously

UPDATE RATE

- Watts, VAR and VA - Every 6 cycles (e.g., 100ms @ 60Hz)
- All other parameters – Every 60 cycles (e.g., 1s @ 60Hz) (1 second for Current Only measurement, if reference voltage is not available)

POWER SUPPLY

- (90 to 400) Volts AC and (100 to 370) Volts DC. Universal AC/DC Supply
- Burden: 16VA max.

COMMUNICATION FORMAT

- 2 Com Ports
- RS485 Port
- IrDA (Through Faceplate)
- Protocol Modbus RTU, Modbus ASCII
- Com Port Baud Rate: (9600 to 57,600)
- Com Port Address: 0-247
- 8 Bit, No Parity
- Modbus RTU or ASCII Protocols

ETHERNET

- 802.11b Wireless
- 10/100BaseT Ethernet (RJ45)
- Modbus TCP Protocol

DIMENSIONS AND SHIPPING

- Weight: 4 lbs
- 7.9H x 7.5W x 3.1D in
- 20.1H x 19.1W x 7.9D cm

COMPLIANCE:

- IEC 687 (0.2% Accuracy)
- ANSI C12.20 (0.2% Accuracy)
- ANSI (IEEE) C37.90.1 Surge Withstand
- ANSI C62.41 – Burst
- IEC1000-4-2 – ESD
- IEC1000-4-3 – Radiated Immunity
- IEC 1000-4-4 – Fast Transient
- IEC 1000-4-5 – Surge Immunity
- UL Listed on E250818

Ordering

PL6100	*	*	*	*	*	Description
Frequency	5 6					Standard Unit with display. All current/voltage/power/energy counters measurement, % load bar, RS485 and IrDA ports and one front test pulse output. 50 Hz AC Frequency System 60 Hz AC Frequency System
Current Inputs		5A 1A				5 Amps 1 Amp
Software			0 THD			No THD Option With THD and Limit Alarms
Power Supply				HI		90-400 VAC / 100-370 VDC
I/O Modules					S W	Serial Port Communication Wireless or LAN Based Ethernet

GEDigitalEnergy.com

IEC is a registered trademark of Commission Electrotechnique Internationale. IEEE is a registered trademark of the Institute of Electrical Electronics Engineers, Inc. Modbus is a registered trademark of Schneider Automation. NERC is a registered trademark of North American Electric Reliability Council. NIST is a registered trademark of the National Institute of Standards and Technology.

GE, the GE monogram, Multilin, FlexLogic, EnerVista and CyberSentry are trademarks of General Electric Company.

GE reserves the right to make changes to specifications of products described at any time without notice and without obligation to notify any person of such changes.

Copyright 2015, General Electric Company. All Rights Reserved.

GEA-12825A|E
English
150213



imagination at work