

GE  
Grid Solutions

# Dead Tank Circuit Breakers

Advanced High Voltage Switchgear Technology  
for Reliable Performance



## Today's Environment

The world needs more & cleaner electrical energy, leading to a fast evolution in power generation and grid adaptation. The International Energy Agency (IEA) estimated that in order to achieve target of net zero emission by 2050, share of electricity in total energy consumption will surge from 20% by 2020 to 49% by 2050. To achieve this radical transformation, IEA estimates annual investment of USD2.3 trillion in 2020 will surge at about USD5 trillion in 2030.

Utilities are struggling with the increasing challenge of integrating renewable energy sources into the grid. Integration can conflict with existing modernization and optimization plans. Issues of reliability, safety, power quality and economics have to be taken into account when planning substations and choosing switchgear.

Additionally power systems are already interconnected, highly complex networks that are susceptible to instabilities. Utilities face several challenges in managing and maintaining today's complex grid, including:

- Increasing grid efficiency and resilience without the necessary funding to invest in new capital equipment.
- Expertise to manage the grid is rapidly diminishing due to the exit of skilled, technical resources from the workplace.

Overall, utilities are under intense scrutiny, by both regulatory agencies and the public, to prevent catastrophic power system failures today and in the future

## References

[https://iea.blob.core.windows.net/assets/deebef5d-0c34-4539-9d0c-10b13d840027/NetZero2050-ARoadmapfortheGlobalEnergySector\\_CORR.pdf](https://iea.blob.core.windows.net/assets/deebef5d-0c34-4539-9d0c-10b13d840027/NetZero2050-ARoadmapfortheGlobalEnergySector_CORR.pdf)

## Dead Tank Circuit Breakers Overview

GE offers utilities advanced solutions to improve grid stability and increase efficiency of transmission infrastructure. High-voltage circuit breakers, the heart of power systems, protect electrical equipment and infrastructure, fulfilling operational and safety functions. In normal operation, they carry nominal load currents, and depending on the installation, switch various equipment such as lines or transformers.



When a fault occurs, it is the job of the circuit breakers to interrupt short-circuit currents, specifically those that may reach 20 to 25 times the rated nominal current, within milliseconds. The magnitude of the interrupted power may be of an order comparable to the power consumption of a major city. Even after prolonged intervals of several years, the breakers must absolutely guarantee reliable switching performance.

With more than 34,000 Dead Tank Circuit Breakers installed and in service around the world, GE is recognised as one of the technological leaders ensuring reliability and safety of operations at an optimized cost.

GE's SF<sub>6</sub> circuit breakers are well known for quality, performance and reliability. As a change leader, GE has developed SF<sub>6</sub>-free high voltage switching equipment using an alternative gas known as g<sup>3</sup>. Initially launched in GIL/GIL configuration there is now wide approval of the technology which is currently being applied for high voltage dead tank circuit breakers. Please contact your GE representative for the latest g<sup>3</sup> product roadmap including dead tank circuit breakers.



# The GE Advantage

GE's Dead Tank Circuit Breakers are developed based on the highest standards for performance, ratings, user convenience and reliability. Every circuit breaker model is thoroughly tested to meet or exceed the latest IEEE and IEC standards including Class C2, Class M2, fast TRV and high asymmetry.

## Unique and Superior Design Provides Optimal Performance and Lower Total Cost of Ownership

- Durable spring-spring mechanism provides 5 times more reliability than hydraulic, pneumatic or hydraulic-spring designs according to CIGRE report 510.
- Innovative interrupter design with self-blast technology reduces required mechanical energy to clear fault currents without any sacrifice in performance or reliability.
- Designed and tested to operate within extreme environmental conditions with available options for high elevation, very low and high temperatures (-60° C to +60° C), seismic zones, polluted areas, and corrosive atmospheres.

## Manufacturing Excellence to Ensure Highest Quality Standards

- Global manufacturing sites are certified according to ISO 9001, ISO 14001 and ISO 45001.
- Products are manufactured using GE's Advanced Production System ensuring the highest level of quality
- Available customization expertise to meet customer unique application requirements

## Extensive Research, Testing and Proven Field Experience Resulting in Enhanced Reliability

- R&D Competence Center and associated testing laboratories located at GE's Charleroi, Pennsylvania, United States facility.
- R&D facilities in Charleroi, Pennsylvania carry ISO 17025 American Association for Laboratory Accreditation (A2LA)
- Dead Tank Circuit Breakers are type tested for more than 10,000 mechanical operations exceeding IEEE and IEC Class M2 standards
- Industry-leading SF<sub>6</sub> tightness testing system, guaranteeing lower than 0.5% annual emission rate through quantified routine tests for every Dead Tank Circuit Breaker manufactured in the Charleroi plant.
- To date there are over 34,000 dead tank circuit breakers installed and in service in more than 60 countries.

## Optional Features for Enhanced System Compatibility, Digital Integration and In-House Expertise

- Complete monitoring system available for asset management and digital substation integration
- Independent pole operation with Point-on-Wave switching available when required for specific applications.
- Metal Oxide Varistors (VAR) available for shunt reactor switching
- Pre-Insertion Resistors for line switching and special switching applications.
- Full life-cycle support for products, spare parts management and technical training by circuit breaker experts
- Local Product Sales Specialists provide strong product and technical support



# GE's Dead Tank Circuit Breaker Technologies, Unique and Superior Design

GE offers a complete range of Dead Tank Circuit Breakers for the protection of critical assets. GE's Dead Tank Circuit Breakers product line, the DT Series, supports system voltages from 38 kV to 550 kV and are designed for performance, high reliability, maximized safety and lower cost of ownership.

The DT Series is designed with optional features to operate within extreme environmental conditions including high elevation, very low and high temperatures (-60°C to +60°C), seismic zones, polluted areas and corrosive atmospheres.

The breakers are designed and tested to meet or exceed the requirements of IEEE and IEC standards including Class M2, for mechanical endurance, Class C2, including back-to-back capacitance switching, and transformer limited faults.

Gang operation (GO) is standard (up to 245 kV), and Independent Pole Operation (IPO), is available at all voltage levels.

## Spring-Spring-Operated Mechanisms

GE has been developing and manufacturing spring-spring-operated mechanisms since 1938. The most recent state-of-the-art evolution for these mechanisms is the FK3 range. The FK3 which is used for all GE high voltage switchgear applications including dead tank, live tank, generator circuit breakers, GIS and hybrid solutions. Over 200,000 FK3 mechanisms are in service worldwide.

The FK3 low energy spring-spring mechanism provides the highest level of reliability with Class M2 performance for 10,000 no-load close-open operations without the need for routine maintenance. With a spring-spring operated mechanism there are no pneumatics or hydraulics, ensuring safe, reliable and maintenance-free operation for the normal circuit breaker service life of up to 50 years or more.

Additionally, the FK3 series offers very stable operating times with minimal risk of mechanical scatter, making the mechanism well suited for controlled switching applications including shunt capacitors, shunt reactors and transformers.

## Interrupting Chamber

GE circuit breakers use a proven innovative interrupter design with over 30 years of in-service experience using self-blast technology that significantly reduces the required mechanical energy to clear short-circuit currents. The interrupter design uses the arc energy to generate gas compression for the efficient quenching of the arc itself.

As a member of the puffer family, the interrupter has two gas volumes within the chamber, one mechanical and one thermal. The purpose of the interrupter ensures that the circuit breaker will interrupt all short-circuit fault currents from low level faults to the full nameplate rating.

The single-pressure interrupter uses partial duo-flow, self-blast technology to control and cool the SF<sub>6</sub> exhaust, ensuring proper gas density and dielectric strength while at the same time reducing the risk of contamination. This design ensures long reliable life even as the circuit breaker ages with time and use.

The interrupter housings are made as single-piece aluminum castings, designed to ensure gas tightness and with safety margin for dielectric strength. GE's proprietary particle trap configuration is incorporated in all designs to provide an extra measure of dielectric security.

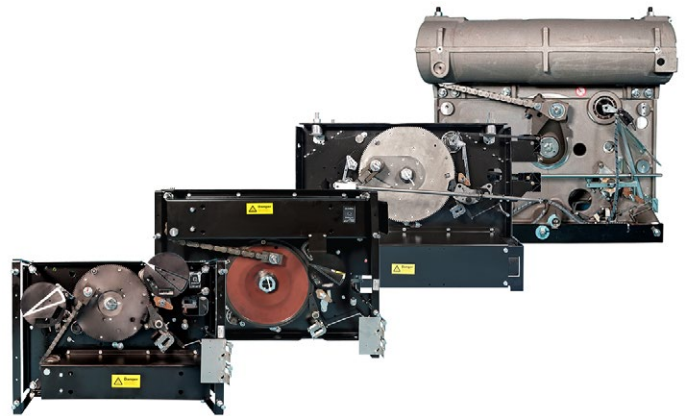

FK3-X mechanism range used in the DT-Series

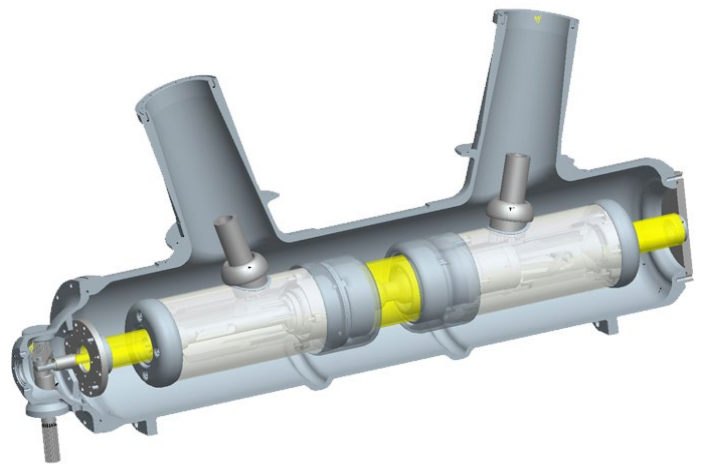

Interrupting chamber of a 245 kV circuit breaker

# Technical Data

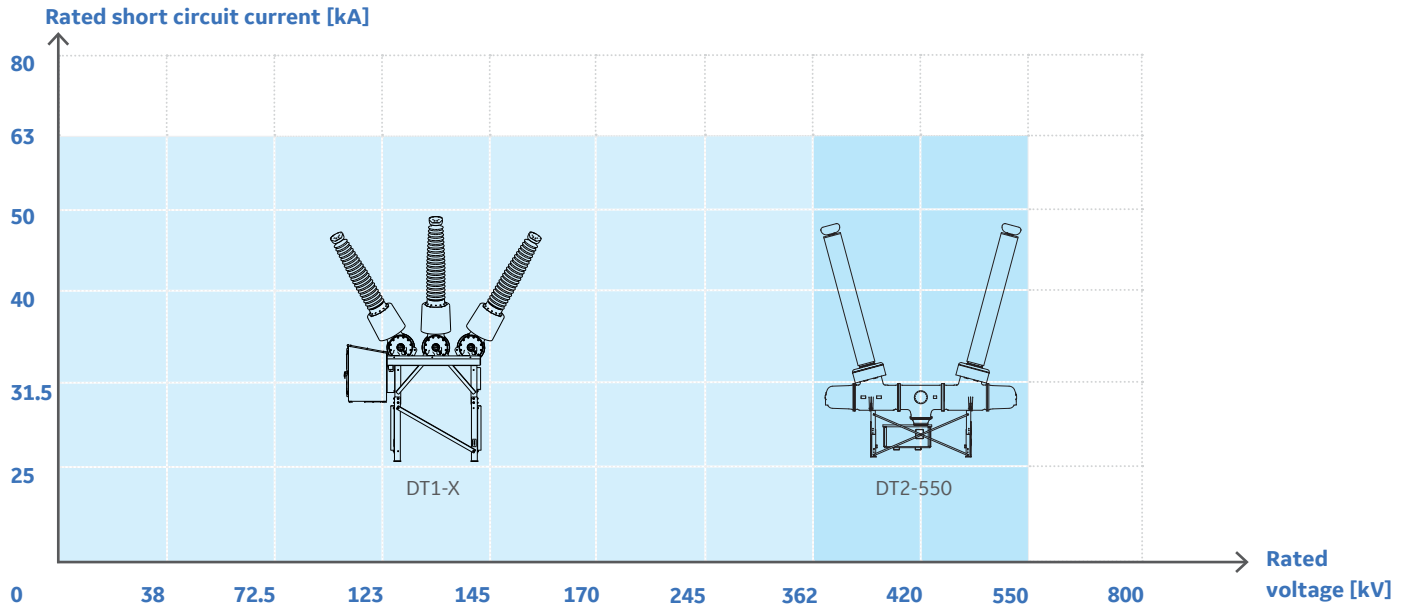

# Technical Data

IEEE Standards	IEC Standards	Units	DT1-X					DT2
Rated maximum voltage	Rated voltage	kV	38	72.5	123/145/170	245P-40/245P-63	362	550
Rated power frequency	Rated frequency	Hz	50/60					
Rated Power Frequency Withstand -1 min Dry withstand -10 s Wet withstand	Rated insulation level - At power frequency, dry - At power frequency, wet	kV	80	160	260/310/365	425	555	860
		kV	75	140	230/275/315	420	N/A	N/A
Rated full wave lightning impulse withstand voltage	At lightning impulse	kV	200	350	550/650/750	900/1,050	1,300	1,800
Rated chopped wave impulse voltage 2us		kV	258	452	710/838/968	1,160	1,680	2320
Rated continuous current (60Hz) up to	Rated normal current, up to	A	3,000	3,000	4,000	5,000	5,000	5,000
Rated short circuit and short time current up to	Rated short-circuit breaking current up to	kA	40	40	40/63	40/63	63	63
Rated closing and latching current		kA	104	104	104	104/164	164	164
	Rated short-circuit making current	kA	104	104	104-172	108/172	172	174
Rated interrupting time		Cycles	3	3	3	2/3	2	2.5/2.0
	Rated break time	ms	50	50	50	33/50	33	42/33
Rated standard operating duty cycle	Rated operating sequence		O-0.3s-CO-15s-CO		O-0.3-CO-15s-CO			
			O-0.3-CO-180s-CO					
Temperature range		°C	-30 to +40 (options for - 55 to +55 available)					

\* All values are in accordance with IEEE and IEC standards. Higher values are available on request. Please contact GE teams for special purpose, high TRV, high X/R or other ratings requirements.

## Manufacturing Excellence

GE's investments in Research and Development (R&D) are significant, allowing utilities and grid operators to benefit from the latest technologies and innovations.

The facilities for research and development and manufacturing are based in the United States, Canada, France and Germany. The same industrial concept is applied in all locations.

## Advanced Production System

The Advanced Production System (APS), is the framework for contemporary manufacturing excellence in Grid Solutions sites. It is based on lean tools for continuous improvement of safety, quality, cost and delivery.

APS brings together a wide range of best practices and standards in seven domains such as Basics, Environmental, Health & Safety (EHS), Supply Chain, Project Delivery, Manufacturing, and Quality & Leadership to create and sustain world class manufacturing excellence.



*Low Voltage Wiring - local customization of low voltage control cabinets and mechanism cabinets based on user specifications.*

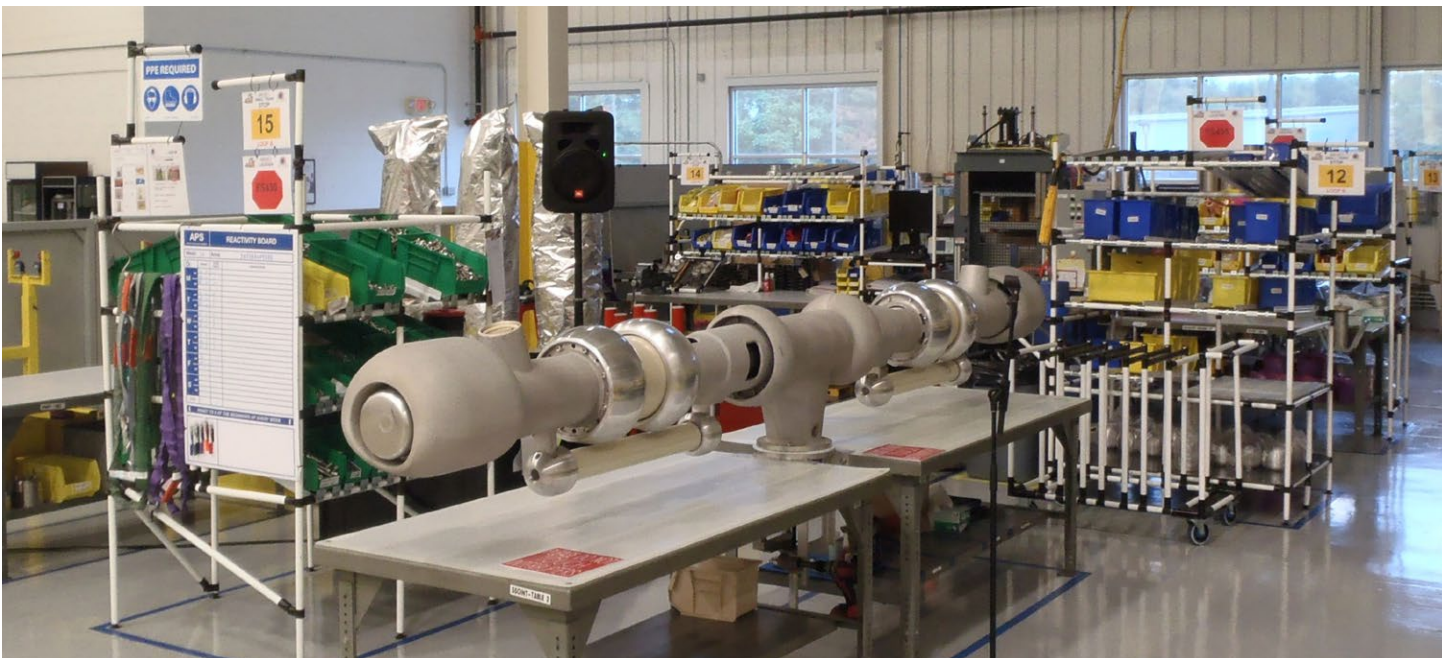

*Assembly of Interrupter – 550 kV Interrupter in a clean room environment.*

## Certified Quality

Research and Development (R&D), manufacturing and commercial units are fully certified according to ISO 9001. This means that during the entire production process, all employees, all equipment and all of the company's operations are dedicated to the highest quality standards and permanent improvement.

The Quality Management System assures the highest level of quality at every step of the value chain. Qualified staff on the Dead Tank Circuit Breaker production lines have proven experience in circuit breaker assembly.

For each step of the production process, detailed operational instructions are used at the respective workstation. Complete traceability of material and workmanship is ensured by means of robust processes and quality controls.



*Dead Tank Circuit Breaker Assembly – installation of interrupters and current transformers to 72.5 kV dead tank circuit breakers.*

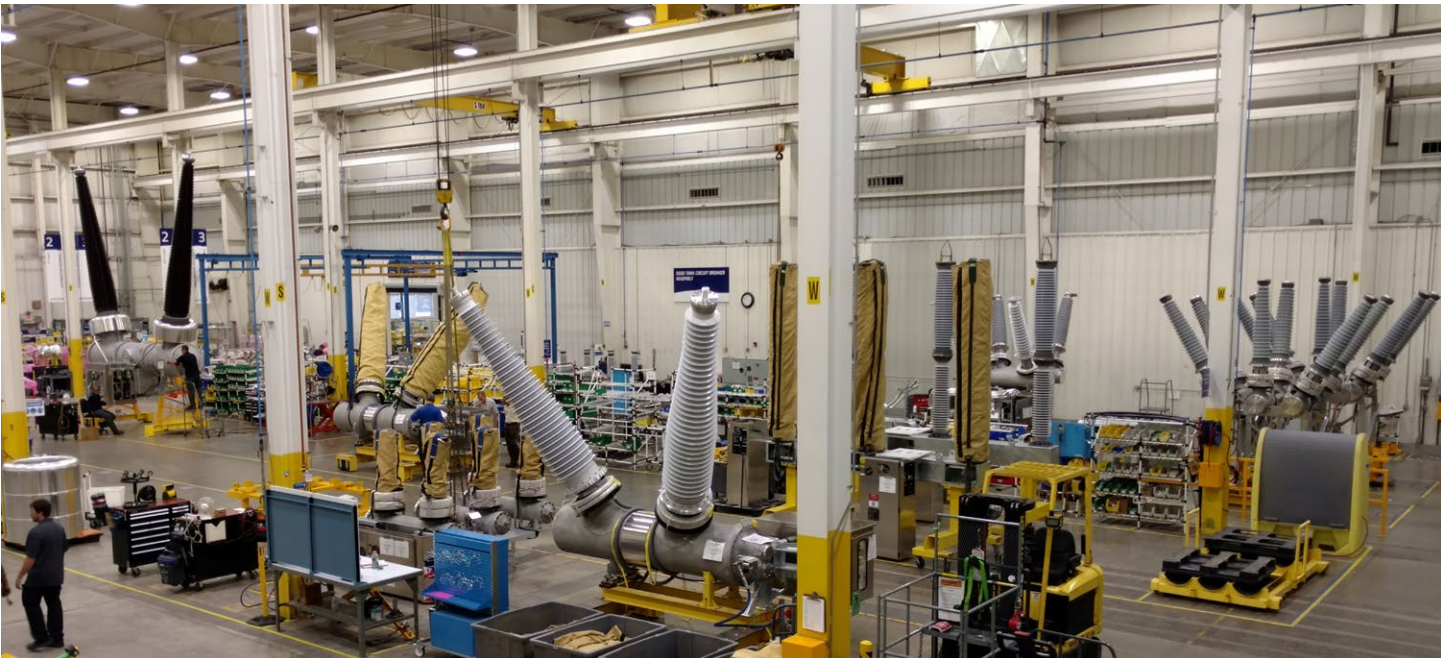

*Clean Room Assembly Hall - dead tank circuit breakers before routine testing.*

## Extensive Testing Capabilities

All dead tank circuit breakers are type tested in world class laboratories such as KEMA, CESI and CERDA, in full compliance with applicable international standards such as ANSI, IEEE, IEC, GOST and DL standards. Specific homologation processes (additional tests, specific reports) are provided as per customer requirements.

### Following tests are performed according to the latest applicable standards:

- Seismic performance
- Dielectric performance including BIL, SIL, RIV, AC withstand and partial discharge
- Mechanical endurance
- Power testing including short circuit, short time withstand, capacitance switching and reactor switching
- Temperature rise continuous current test
- Environmental testing





# Leading Factory and Center of Excellence Charleroi, Pennsylvania, USA

## Highlights

- Manufacturing of dead tank circuit breakers up to 550 kV, live tank circuit breakers up to 800 kV and instrument transformers up to 800 kV.
- Annual production capacity of 3,000+ circuit breakers
- Site is certified to ISO 9001, ISO 14001 and ISO 45001
- A2LA accredited testing facility ISO 17025
- Manufacturing of interrupters for all dead tank circuit breakers produced in Charleroi, PA
- Complete wiring and assembling of low voltage control cabinets and mechanism cabinets locally resulting in greater flexibility to respond to user needs
- 34,000+ circuit breakers delivered from Charleroi site since 1994 (AEG T&D)



*Charleroi Dead Tank Circuit Breaker Center of Excellence*

## Extensive Testing Capabilities

The Research and development laboratories located at the Charleroi plant are certified to ISO 17025 standards and offer extensive testing capacity for development and production testing including; two high voltage test labs, a climatic chamber, continuous current testing, six mechanical testing bays, a prototyping lab and four SF<sub>6</sub> gas tightness testing systems.

## Gas Tightness Testing System

GE has perfected an industry best testing system which measures SF<sub>6</sub> gas tightness and quantifies the exact emission rate, with an accuracy of 0.2 grams per year, for every dead tank circuit breaker assembled in the Charleroi plant.

*Chambers for gas tightness testing*



## Improved Leakage Rate

In use since 2010, every dead tank circuit breaker manufactured in the Charleroi plant is tested with GE's innovative gas tightness technology.

All circuit breakers are tested once fully assembled with bushings installed. Whereas other technologies, such as helium mass spectrometer, only tests smaller components, such as castings.

High accuracy measurement of emission rates below 0.5 % per year is demonstrated in a production environment as a standard routine test.

# Optional Features for Advanced Systems Capabilities

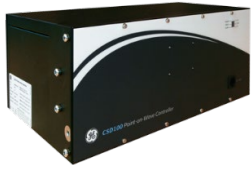

## Controlled Switching Device CSD100

The CSD100 solution, which is the full digital interface between the circuit breakers and the substation, helps circuit breakers to close or open at the optimal time. Controlled switching is used for switching shunt capacitor banks, shunt reactor banks and power transformers.



## MOV (Metal Oxide Varistors)

Optional externally mounted MOV for shunt reactor switching can extend the electric life of high voltage circuit breakers that are used for frequent shunt reactor switching operations.



## Modular Circuit Breaker Monitoring CBWatch

CBWatch monitors critical circuit breaker health indicators, such as gas density, timing, travel and contact wear. This allows users to optimize and schedule maintenance programs accordingly. The collected data can easily be integrated to asset management programs.



## Low Temperature Applications

Dead tank circuit breakers provide sealing and breaking performance as well as mechanical operations guaranteed at very low temperatures, down to  $-60^{\circ}\text{C}$ , with optional tank heaters or gas mixtures. This ensures a reliable performance even in the harshest environments around the world.

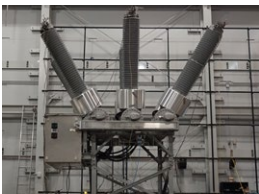

## High Seismic Ratings

Dead tank circuit breakers are available with high seismic performance in accordance with IEEE 693. This standard qualifies the circuit breakers for earthquake levels up to 1.0 g.

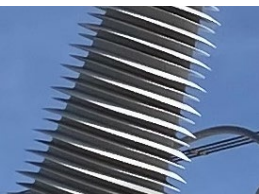

## Composite Insulators

Composite insulators are significantly lighter and less susceptible to damage by strikes and blows than porcelain insulators. For use in seismic areas, the sensitivity to impact loads and the low weight are considerable advantages. Additionally thanks to silicone's hydrophobic (water-repellent) properties, water just rolls off and does not develop a constant moisture film, specifically in highly polluted and coastal regions.



## Pre-Insertion Resistors (PIR)

Series closing resistors limit overvoltages associated with switching unloaded transmission lines and shunt capacitor banks. They reduce voltage disturbances and increase the life of associated equipment in the substation.

# Value Added Services

## Optimizing Asset Reliability, Up-Time and Performance

Dedicated project teams are located in all regions throughout the world. These on the ground teams provide support and expertise to assist customers during different project phases. Local field service teams are also available worldwide, providing immediate support, training and supervision.



### Asset Performance Management

As part of optimizing the maintenance and asset replacement strategies, GE employs stress assessment analysis, SF<sub>6</sub> monitoring and online condition monitoring to allow comprehensive centralized asset management.



### Renovation & Modernization

GE has the technical expertise to deliver customized engineered solutions to extend the life of ageing equipment. GE Service Teams are experienced in solving obsolescence issues and overhauling substation equipment as required.



### Maintenance and Spare Parts

Maximizing the life cycle performance of circuit breakers through the right maintenance strategy, strategic spare parts stock and toll-free 24/7 hotline.



### Technical Training

GE provides on site technical training such as modular and competence development training as well as e-learning and educational partnerships. These skills not only enhance team knowledge, but increase productivity.



# Digital Tools that simplify the entire product lifecycle.

Get your Grid Passport and explore 24/7 Online or on your mobile device



## Explore Grid Challenges

"Fly-Through" an interactive power system that features an in-depth look at the challenges of modernizing the grid from the power plant to the power consumer.



## Discover Solutions

Get hands-on with GE solutions through a broad range of advanced digital tools including real-time 3D product explorers and interactive episodes.



## Configure & Buy

Easily specify, configure, and buy GE solutions 24/7 online with interactive selector guides, simple to use product configurators, and our online store.



## Learn & Implement

Access videos anytime, anywhere, and learn advanced power system applications from industry experts, get quick answers from technical experts, and more.



Access our digital tools online at [GEGridSolutions.com](https://www.gegridsolutions.com)

GE

2018 Powers Ferry Road  
Atlanta, GA 30339 USA

1-877-605-6777 (toll free in North America)

1-678-844-6777 (direct number)

[GEGridSolutions.com](https://www.gegridsolutions.com)

GE and the GE monogram are trademarks of General Electric Company.

GE reserves the right to make changes to specifications of products described at any time without notice and without obligation to notify any person of such changes.

Copyright 2022, General Electric Company. All Rights Reserved.

GEA-31987A(E)  
English  
220629

