

Multilin C650

Bay Control & Monitoring System

The Multilin™ C650 has been designed for electrical substations. The substation hardened Multilin C650 is designed to perform substation control and monitoring that can also be used to expand the I/O capability of protection devices.

The C650 is a flexible, reliable and cost-effective solution that spans low-end MV/LV to high-end HV substation applications. Graphical programming tools, supported by a library of logic operators, make the C650 simple to use and configure. Designed with advanced communications options and detailed monitoring capabilities, the Multilin C650 provides advanced functionality, including up to 192 programmable digital inputs, control functions and flexible configuration capabilities.

Key Benefits

- Flexible, powerful and deterministic programmable logic suitable for creating many customized automated substation control solutions
- Human machine interface (HMI), graphical LCD, programmable buttons, and easy keys for selecting setting menus, and submenus.
- Modular hardware architecture allowing for flexibility in the I/O configuration to support various applications
- IEEE 1588, IRIG-B and SNTP time synchronization, event reports, waveform capture, data logger simplifying post fault analysis
- Advanced automation enabling for providing customized control solutions
- Reduced relay to relay wiring and associated installation costs through high-speed inter-relay communications
- Simplified system integration with communications supporting serial and Ethernet interfaces and multiple protocols including IEC 61850 edition two
- Increase network availability by reducing failover time to zero through IEC® 62439 PRP/HSR and IEEE® 802.1D/RSTP
- Scalable solutions for I/O units (Up to 192 DI or 48 DO depending on the model)
- Significant savings in installation costs with support for up to two remote CAN Bus IO modules

Applications

- Bay control and substation automation for solidly grounded, high impedance grounded or resonant (Peterson Coil) grounded systems
- Bus blocking/Interlocking schemes
- Throw over schemes (bus transfer scheme applications)
- Load shedding schemes based on voltage and frequency elements or pre-defined shedding scenarios
- Programmable Logic Control



Flexible Control

- Advanced control functionality including four shot autoreclose
- Breaker control
- Selectively enabled Synchrocheck Element - V, j, f & Hz
- Up to 192 Programmable digital inputs and up to 48 digital outputs
- Trip Circuit Supervision for breaker health monitoring
- Extensive logic capability with high speed logic execution time

Monitoring & Metering

- Comprehensive breaker operation monitoring
- Fault and event recorder (479 events)
- High resolution oscillography and Data Logger, with programmable sampling rate
- Metering: V, I, Hz, W, VA, PF
- Demand: I_a, I_b, I_c, I_{sg}, I₂, MW, MVA
- Configurable graphical HMI interface
- Alarm Panel

EnerVista Software

- Sophisticated software for configuration and commissioning
- LaunchPad: document and software archiving management system
- EnerVista™ Integrator providing easy integration of data in the C650 into new or existing monitoring and control systems



Substation Automation Controller

GE's C650 is a powerful, flexible and high speed control device in 650 platform, suitable for substation automation implementations. Along with a set of flexible I/O, The C650 is designed to provide high speed control functions for bay control applications.

Autorecloser

This function is applicable of three-pole tripping schemes and single breaker applications. Four reclosing "shots" are possible prior to locking out, each with an independent time setting. Auto reclosure outputs can be used to modify circuit protection settings between shots.

Synchronism Check

The Synchrocheck element is used for monitoring the connection of two parts of the circuit by the closure of a breaker. Breaker closing can be supervised by ΔV , Δf and ΔHz setpoints. This element verifies that voltages at both sides of the breaker are within the magnitude, angle and frequency limits set by the user before closing the breaker, in order to minimize internal damage that could occur due to the voltage difference, both in magnitude and angle.

Advanced Automation

The C650 incorporates advanced automation features that replaces multiple devices with a single unit and includes powerful programmable logic, communications, and SCADA capabilities that far surpass what is found in the average controller relay. The C650 provides seamless integration with other GE Multilin devices for comprehensive system automation and control.

C650 Logic Configuration

C650 Logic Configuration is the powerful programming logic engine that provides the ability of creating customized protection and control schemes thereby minimizing the need, and the associated costs, of auxiliary components and wiring.

Inputs and Outputs

The C650 offers a variety of different IO configurations based on user's need.

A choice of 16 to 192 inputs, 0 to 48 outputs and two outputs with coil monitoring are available. Digital inputs may be user defined with a separate debounce and chatter time. Programmable "quasi" analog input levels allow the use of different voltage levels in the same model via setting the requested thresholds. EnerVista™ software allows easy configuration of all the interlocking and switching sequences. A graphic HMI interface provides access to monitoring, metering and alarm panel screens.

Virtual Inputs/Outputs

Traditionally, relay logic has been relatively limited. Use virtual inputs and outputs in conjunction with the programmable logic capabilities of the C650 for unusual applications involving interlocks, blocking, or supervisory functions, to minimize the requirement for auxiliary components and wiring while making more complex schemes possible.

The virtual inputs and outputs are digital signals associated with the C650 internal logic. Virtual inputs include signals generated remotely via communications. The virtual outputs are outputs of programmable logic equations used to customize the device. Virtual outputs can also serve as inputs to programmable logic equations.

Transducer Inputs

dcmA inputs are available to monitor system parameters such as temperature, vibration, pressure, wind speed, and flow.

Remote I/O

The remote I/O feature provides a means of sharing digital point state information between C650s or other IEC61850 compliant IEDs or controllers. The remote outputs interface seamlessly to the remote inputs of other C650 devices via the IEC61850 GSE messaging. User secure peer-to-peer communications to develop complex schemes in distributed logic and I/Os.

Functional Block Diagram

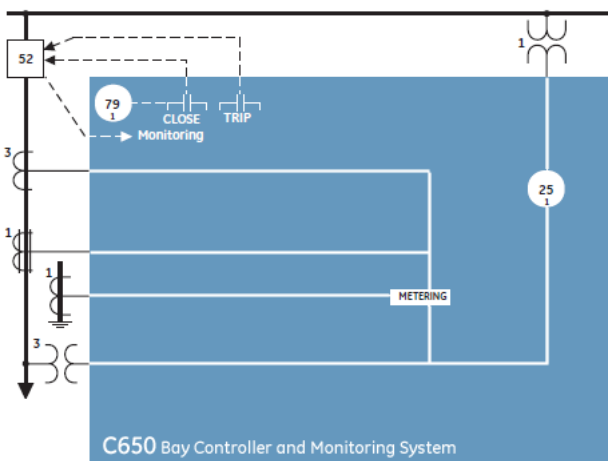

ANSI® Device Numbers & Functions

DEVICE NUMBER	FUNCTION
25	Synchrocheck
79	Autorecloser

Flexible Substation Communications & Control

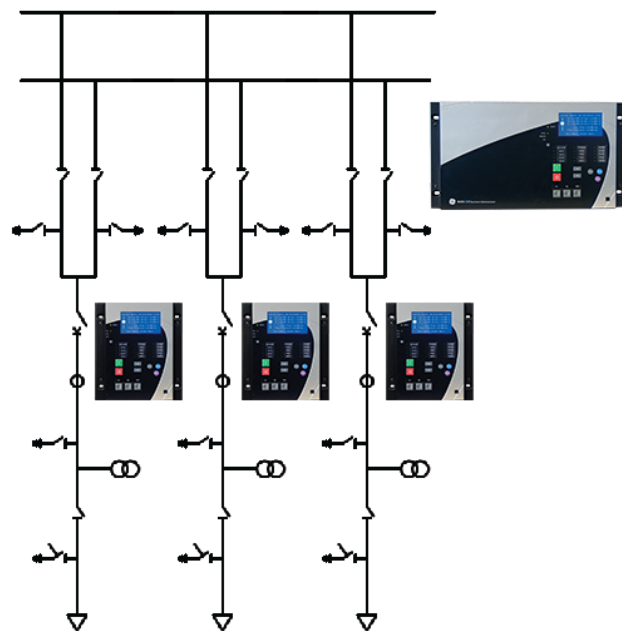

The C650 bay control and monitoring device features outstanding automation functions for advanced switchgear interlocking applications

650 Logic Configuration

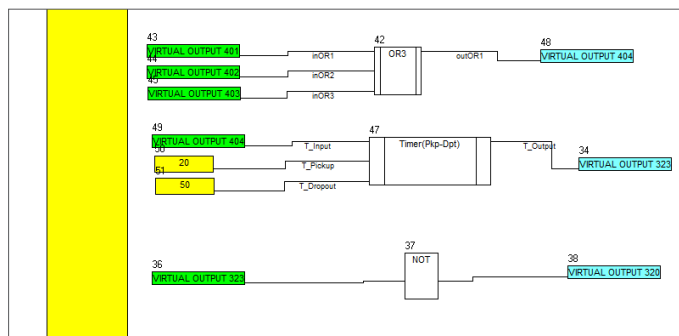
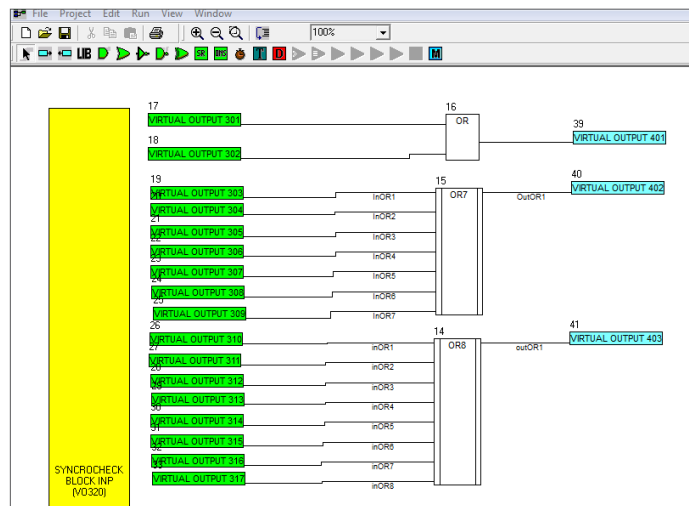

650 Logic Configuration is a powerful programming logic engine that provides the ability of creating customized protection and control schemes.

Redundant HSR and PRP architecture capabilities

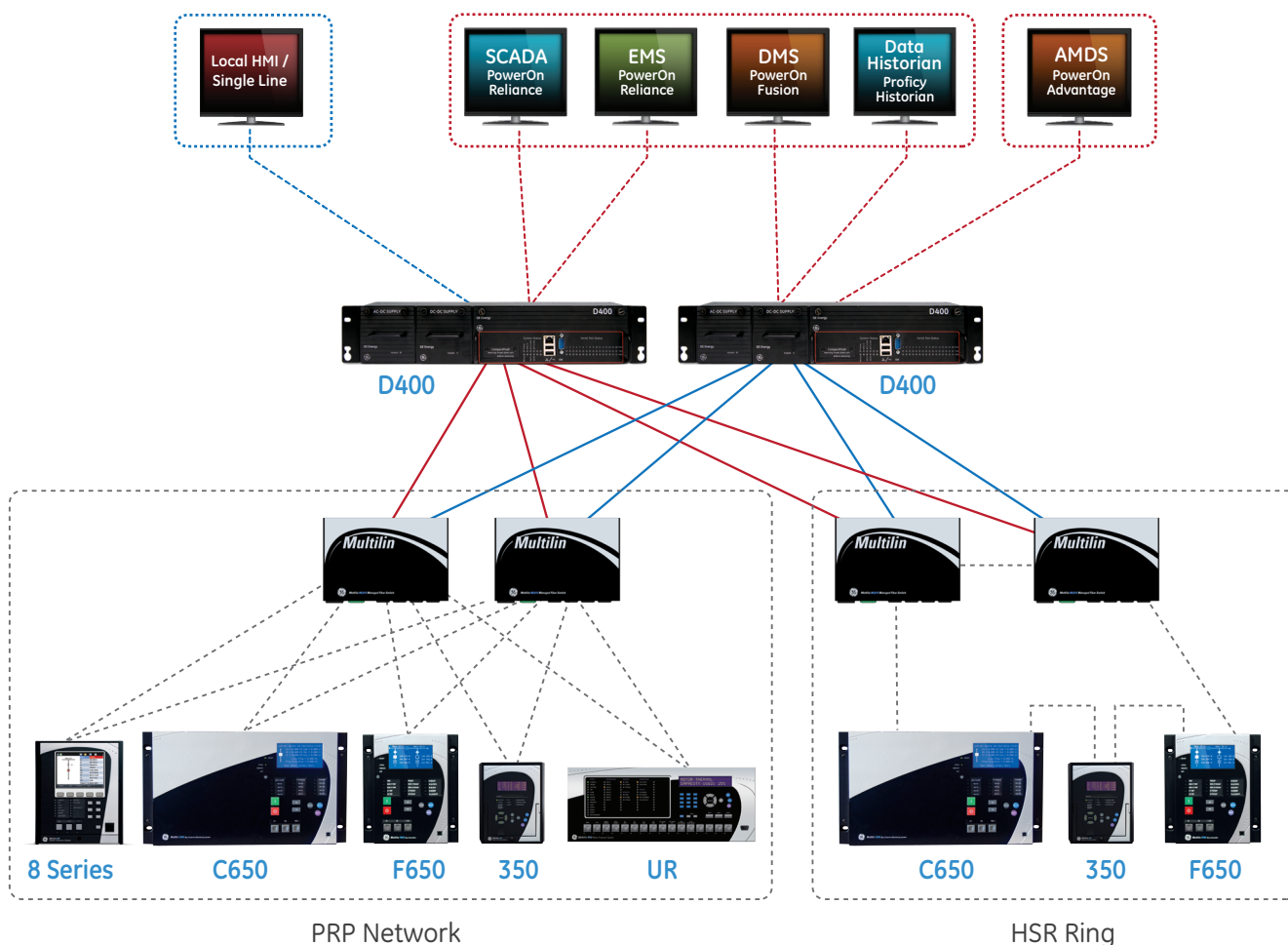

Redundancy protocols (PRP and HSR) can be used for various networking architectures including combined PRP/HSR topologies.

CAN BUS Remote I/O

The C650 can be ordered with up to two additional communication cards on the rear. Besides two identical ports, COM1 and COM2, the cards may incorporate a port for CAN BUS communications used to connect the Remote CAN BUS I/O module (CIO Module). Although C650 benefits from large number of IOs, CIO modules can be used on 1/2 rack model to increase the number of IOs.

In addition to increasing the number of I/Os, the CIO Module allows the C650 to monitor signals located at a remote location with only a connection between both devices, resulting in significant savings in installation costs.

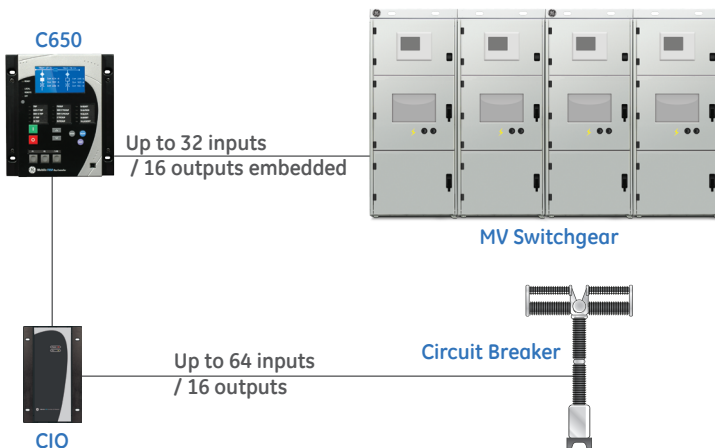

Monitoring and Metering

The C650 provides advanced monitoring and metering that includes:

Trip-Close Circuit Monitoring

C650 can be used to monitor the integrity of both the breaker trip and closing coils and circuits. The supervision inputs monitor both the battery voltage level, while the outputs monitor the continuity of the trip and/or closing circuits, by applying a small current through the circuits.

Metering

The C650 supports the most common metering for bay control and automation applications. All measured parameters are available locally and remotely and can be stored in the oscillography record or data logger.

Metered values include:

- Current: $I_a, I_b, I_c, I_n, I_g, I_{sg}$
- Phase-to-phase and phase-to-ground voltages for bus and line:
 $V_{an}, V_{bn}, V_{cn}, V_{bb}, V_{ab}, V_{bc}, V_{ca}$
- Active power (per-phase and total): W_a, W_b, W_c, W
- Reactive power (per-phase and total): VAR_a, VAR_b, VAR_c, VAR
- Apparent power (per-phase and total): VA_a, VA_b, VA_c, VA
- Total active, reactive energy: MWh, MVARh
- Power factor (per-phase and total)
- Frequency
- Demand

$I_a, I_b, I_c, I_g, I_{sg}, V_a, V_b, V_c$ and V_x signals are available locally and remotely and can be stored in the oscillography record or data logger.

Event Recording and Oscillography

The C650 is capable of storing 479 time-tagged events (1 ms tagging), to help with troubleshooting. The trigger point, the channels, and sampling rate of the oscillography files are user programmable features. Up to five seconds at maximum sample rate can be stored.

Breaker Arcing Current (I^2t)

The relay estimates the total interrupted current as an accumulation of the RMS current measured during the time period taken to open the breaker after a trip. It calculates the per-phase wear on the breaker contacts to establish a threshold. When the breaker maintenance threshold is exceeded the relay can be set to trigger an alarm.

Communications

The C650 incorporates industry-leading communication technologies making it one of the easiest and flexible controllers for use and integration into new and existing infrastructures.

The C650 provides up to three communication ports that operate simultaneously. Redundant ports are also available for special applications. C650 features a USB front port (COM2), and another rear 10/100 BaseTX and 100 Base FX single or redundant Ethernet ports. Besides, a rear RS485 serial port (COM1) is possible.

The C650 provides optional Parallel Redundancy Protocol (PRP), High Availability Seamless Ring (HSR) (IEC 62439-3) and also Rapid Spanning Tree Protocol (RSTP) (IEEE 802.1D) to increase network availability and reliability for critical applications.

The basic concept of both protocols, PRP and HSR, is to send identical frames over different paths and discard one of the copies in reception, at best. If an error occurs or one of the paths goes down, the frame travelling through that path will not reach its destination, but its copy remains intact and will reach the desired destination. This technology ensures high reliability and availability of communication networks by providing redundancy and zero reconfiguration time in the event of a failure. Failsafe communications systems are crucial for industries and utilities with critical applications where no recovery time is tolerated.

The C650 supports popular industry leading standard protocols enabling easy, direct integration into electrical SCADA and HMI systems. The protocols supported by the C650 include:

- IEC 61850 Edition 2
- DNP 3.0
- Modbus® RTU
- Modbus TCP/IP
- IEC 60870-5-104
- PRP & HSR (IEC 62439-3)
- RSTP (IEEE 802.1D)
- IEEE 1588 (PTP) for time synchronization

These protocols make it easy to connect to a utility automation system and are integrated into the C650, eliminating the need for any external protocol converter device.

Security

Independent passwords for protection and control allow restricting access via keypad and display, or EnerVista software.

Interoperability With Embedded IEC 61850 Protocol

IEC 61850 is the international standard for information exchange and interoperability between intelligent devices within a substation. Use the C650 with IEC 61850 to lower the costs and simplify the engineering, commissioning, operating, and maintenance associated with substation protection and control applications.

The C650 provides integration with 61850 standard edition 2. IEC 61850 allows for the seamless connection of IEDs from multiple vendors. In addition to device interoperability, these protocols are designed to control the substation via a LAN instead of through discrete wiring to an RTU. Peer-to-peer communication over Ethernet enables distributed control with several IEDs and eliminates the need for an RTU to remote SCADA master. High-speed message transfer eliminates the need for large and costly hard-wired interconnection.

EnerVista Software

The EnerVista Suite is an industry-leading set of software programs that simplifies every aspect of using the C650 relay. The EnerVista suite provides all the tools to monitor the status of your the protected asset, maintain the relay, and integrate information measured by the C650 into DCS or SCADA monitoring systems. Convenient COMTRADE and Sequence of Events viewers are an integral part of the 650 Setup software included with every C650 relay, to carry out postmortem event analysis to ensure proper protection system operation.

EnerVista Launchpad

EnerVista Launchpad is a powerful software package that provides users with all of the setup and support tools needed for configuring and maintaining GE Multilin products. The setup software within Launchpad allows configuring devices in real-time by communicating using serial, Ethernet, or modem connections, or offline by creating setting files to be sent to devices at a later time.

Included in Launchpad is a document archiving and management system that ensures critical documentation is up-to-date and available when needed. Documents made available include:

- Manuals
- Application Notes
- Guideform Specifications
- Brochures
- Wiring Diagrams
- FAQ's
- Service Bulletins

Viewpoint Monitoring

Viewpoint Monitoring is a simple-to-use and full-featured monitoring and data recording software package for small systems. Viewpoint Monitoring provides a complete HMI package with the following functionality:

- Plug-&-Play Device Monitoring
- System Single-Line Monitoring & Control
- Annunciator Alarm Screens
- Trending Reports
- Automatic Event Retrieval
- Automatic Waveform Retrieval

Dimensions 19"

SIDE VIEW

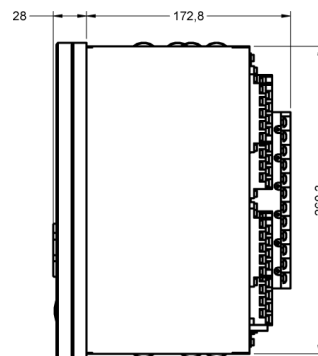

FRONT VIEW

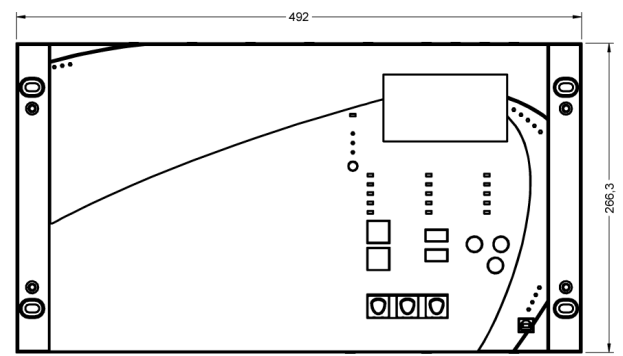

CUTOUT

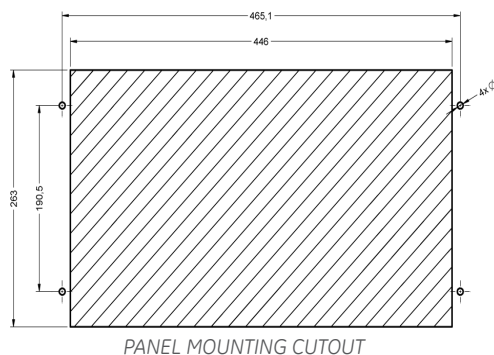

Note: all dimensions are shown in mm (inches)

User Interface 19"



- Display**
 - Graphic 16x40 or text 4x20 LCD display
 - Fluorescent backlight to improve visibility
- LEDs**
 - Multicolor programmable LEDs with label panel
 - Local/Remote/Off pushbutton with LEDs
- Keypad**
 - Local/Remote/Off pushbutton with LEDs
 - Key control for easy navigation
 - Ergonomic programmable keys
- Front Port**
 - Electrically isolated front USB communication port

User Interface 1/2 Rack



- Display**
 - Graphic 16x40 or text 4x20 LCD display
 - Fluorescent backlight to improve visibility
- LEDs**
 - Multicolor programmable LEDs with label panel
 - Local/Remote/Off pushbutton with LEDs
- Keypad**
 - Local/Remote/Off pushbutton with LEDs
 - Key control for easy navigation
 - Ergonomic programmable keys
- Front Port**
 - Electrically isolated front USB communication port

A choice of text or graphic display, and up to five configurable keys are available for frequently performed control functions. Up to 15 programmable LEDs are available. The C650 can incorporate (option "N" for the second position of the ordering code) a Graphical display with IEC Symbols.

Dimensions 1/2 Rack

SIDE VIEW

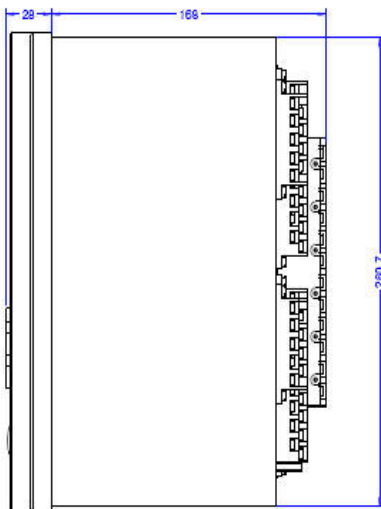

FRONT VIEW

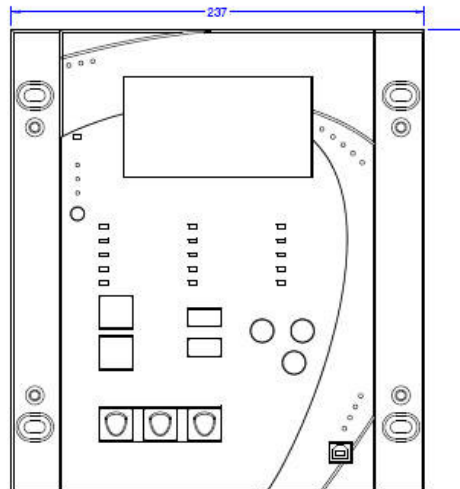

CUTOUT

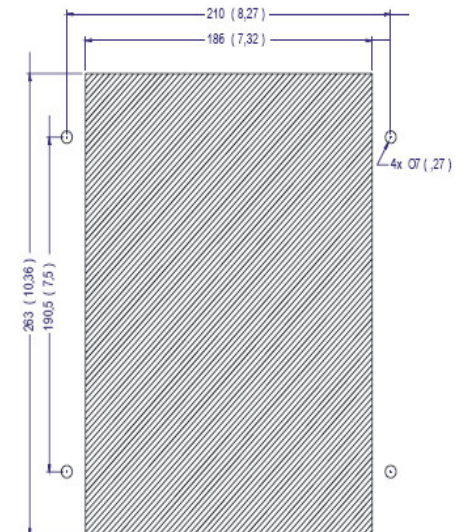

Typical Wiring Diagram

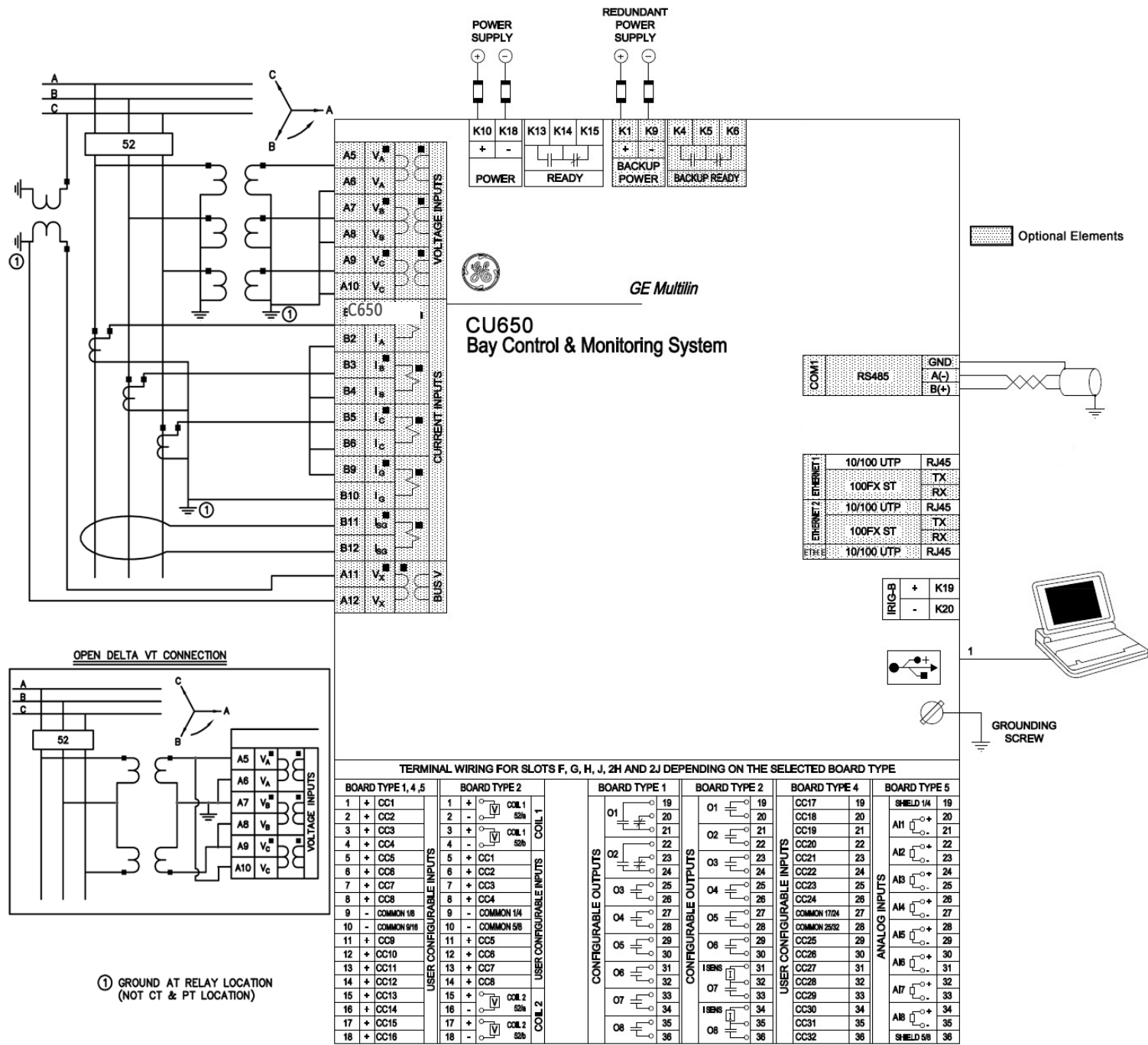

Technical Specifications

CONTROL

AUTORECLOSE (79)

Schemes: Three-phase pole tripping schemes

No. of reclosing shots: Up to 4 reclose attempts before lockout

Dead time: Independent dead time setting before each shot adjustable between 0 and 900 s in steps of 0.01 s

Reclaim time: 0.00 to 900.00 s in steps of 0.01 s

Condition permission: Selectable by setting

Hold time: 0.00 to 900.00 s in steps of 0.01 s

Reset time: 0.00 to 900.00 s in steps of 0.01 s

Snapshot Events: Selectable by setting

Possibility to modify protection settings after each shot

SYNCHRONISM CHECK (25)

Dead/live levels for line and bus:

0.00 to 300.00 in steps of 0.01 V

Maximum voltage difference:

2.00 to 300.00 V in steps of 0.01 V

Maximum angle difference:

2.0° to 80.0° in steps of 0.1°

Maximum frequency slip:

10 to 5000 mHz in steps of 10 mHz

Synchronism time: 0.01 to 1.00 s in steps of 0.01 s

Angle accuracy: 3°

Dead Source function:

- None
- (DL-DB) Dead Line - Dead Bus
- (LL-DB) Live Line-Dead Bus
- (DL-LB) Dead Line - Live Bus

Snapshot Events: Selectable by setting

BREAKER MAINTENANCE

KI² BKR Ph A, B, C Cnt: 0.00 to 9999.99 in steps of 0.01 (KA)²s

BKR Openings Cnt: 0 to 9999 in steps of 1

BKR Closings Cnt: 0 to 9999 in steps of 1

BREAKER SETTINGS

Switchgear number: 1 to 16

Maximum KI²: 0.00 to 9999.99 in steps of 0.01 (KA)²s

KI² integ. Time: 0.03 : 0.25 s in steps of 0.01s

Maximum openings: 0 to 9999 in steps of 1

Maximum Openings in an hour: 1 to 60 in steps of 1

SWITCHGEAR

Switchgear number: 1 to 16

Switchgear: 1 to 16 (configurable).

MONITORING

TRIP/CLOSE COIL MONITORS

Detect open trip and close circuits

OSCILLOGRAPHY

Records: Up to 20 oscillography records.

Samples: Programmable to 4, 8, 16, 32 or 64 samples per cycle

Trigger position: 5% to 95% of total length

Trigger: Programmable via programmable logic

Data:

- 5 current channels and 4 voltage channels
- Up to 16 digital channels selectable from the available internal states programmable through PLC

Storage: Permanent in non volatile memory (flash) without battery In non-volatile memory (flash) without battery

Format: International Standard COMTRADE ASCII - IEEE C37.111-1999.

SNAPSHOT EVENTS

Capacity: 479 scrolling events

Labeling time tag: 1 ms using an internal clock of 100 μ s

Accuracy: 1 ms (using the IRIG-B synchronization input)

Trigger:

- By pickup or dropout or operate of any element
- By change of state in a Digital input/output change of state
- By virtual inputs and control events

Storage: Permanent in non volatile memory (flash) without battery

CONTROL EVENTS

Capacity: 128 events programmable through PLC

Labeling time tag: 1 ms using an internal clock of 100 μ s

Accuracy: 1 ms (using the IRIG-B synchronization input)

Trigger: By any digital signal programmable through PLC

Alarm: Possibility to display the event as an alarm on the alarms panel. Information available always through Communications for all models and also in HMI for models with graphical display (M in ordering code).

Storage: Permanent in non volatile memory (flash) without battery

DEMAND

Channels: 9

Parameters: Ia(kA RMS), Ib(kA RMS), Ic(kA RMS), Ig(kA RMS), Isg(kA RMS), I2 (KA), P(MW), Q (MVAR) and S (MVA)

Current and Power Method: Thermal Exponential, block interval, Rolling demand

Metering Measurements: Each channel shows the present and maximum measured value, with date and time for the maximum recorded value.

Samples: 5, 10, 15, 20, 30, 60 minutes.

Accuracy: $\pm 1\%$

DATA LOGGER

Channels: 1 to 16

Parameters: Any of the analog Metering actual values

Samples: 1 second, 1, 5, 10, 15, 20, 30, 60 minutes.

Capacity: Fixed, (32768 measures)

METERING

CURRENT

Accuracy:

- $\pm 0.5\%$ of the reading ± 10 mA from 0.1 to 10 A (for phases and ground)
- $\pm 1.5\%$ of the reading ± 1 mA from 0.005 to 5 A (for sensitive ground)
- $\pm 1.5\%$ of the reading for higher values

VOLTAGE

Accuracy: $\pm 1\%$ reading, from 10 to 208 V

POWER

Active:

$\pm 2,5\%$ of the reading from power factor ± 0.8 to 1

Reactive:

$\pm 2,5\%$ of the reading from power factor ± 0.2 to 0

Apparent: $\pm 2,5\%$ of the reading

ENERGY

Watts- hour (positive and negative)

Accuracy: 2,5%

Range: ± 0 to 2147 MWh

Parameters: three-phase

Updating Time: 100 ms

Var-hour (positive and negative)

Accuracy: 2,5%

Range: ± 0 to 2147 MVARh

Updating Time: 100 ms

POWER FACTOR

Accuracy: 0.02

FREQUENCY

Accuracy: ± 50 mHz

Accuracy angle: 2°

INPUTS

CURRENT INPUTS

Rated current: Appropriate for 1 or 5 A

LoadRelay Burden: < 0.04 Ohm

Overload:

- 20 A permanent
- 500 A during 1 second

Current Withstand:

- Continuous at 20 A
- 1 second at 500 A for phases and ground
- 1 second at 50 A for sensitive ground

VOLTAGE INPUTS

VAC inputs do not need varistors, as the impulse test is applied to 100% of the transformers

Metering range: From 2 to 275 Vac

LoadRelay Burden: 0.05 VA at 120 Vac (50 or 60 Hz)

Voltage withstand:

260 Vac permanent

Continuous at 275 V to neutral

420 Vac during 1 min/hr at 420 to neutral

DIGITAL INPUTS

Voltage Threshold: Programmable from 20 up to 230Vdc in steps of 1 V

Impedance: > 100 kOhm

Load for voltage supervision inputs: 2 mA + V/100 kOhm

Maximum error: $\pm 10\%$ setting or ± 5 V

Acknowledgement time: < 1 ms

Debounce time: 1 to 50 ms in steps of 1 ms

REMOTE INPUTS

No of input points: 32, configured from 64 incoming bit pairs

No of remote devices: 16

Default states on loss of comms: On, Off, Latest/on, Latest/off

ANALOG INPUTS (DCMA)

Current inputs: 0 to -1; 0 to +1; -1 to +1; 0 to 5; 0 to 10; 0 to 20, 4 to 20

Conversion range: -1 to 20 dcmA

Accuracy: +/-0.2% of full scale

Type: Passive

IRIG-B TIME SYNCHRONIZATION INPUT

Type: Demodulated input (no carrier)

Formats: B000(*) B001, B002 and B003(*)

Level: TTL

Load: 1.5 mA

(*) Signal combinations recognized in accordance with IRIG Standard 200-95

REAL TIME CLOCK

VAC: Typical 20 ppm

Backup energy: More than 1 week

INPUTS

CURRENT INPUTS

Rated current: Appropriate for 1 or 5 A

LoadRelay Burden: < 0.04 Ohm

Overload: 20 A permanent

500 A during 1 second

Current Withstand:

- Continuous at 20 A
- 1 second at 500 A for phases and ground
- 1 second at 50 A for sensitive ground

VOLTAGE INPUTS

VAC inputs do not need varistors, as the impulse test is applied to 100% of the transformers

Metering range: From 2 to 275 Vac

LoadRelay Burden: 0.05 VA at 120 Vac (50 or 60 Hz)

Voltage withstand:

- 260 Vac permanent
- Continuous at 275 V to neutral
- 420 Vac during 1 min/hr at 420 to neutral

DIGITAL INPUTS

Voltage Threshold: Programmable from 20 up to 230Vdc in steps of 1 V

Impedance: > 100 kOhm

Load for voltage supervision inputs: 2 mA + V/100 kOhm

Maximum error: $\pm 10\%$ setting or ± 5 V

Acknowledgement time: < 1 ms

Debounce time: 1 to 50 ms in steps of 1 ms

REMOTE INPUTS

No of input points: 32, configured from 64 incoming bit pairs

No of remote devices: 16

Default states on loss of comms: On, Off, Latest/on, Latest/off

Technical Specifications (Cont'd)

ANALOG INPUTS (DCMA)

Current inputs: 0 to -1; 0 to +1; -1 to +1; 0 to 5; 0 to 10; 0 to 20, 4 to 20

Conversion range: -1 to 20 dcma

Accuracy: +/-0.2% of full scale

Type: Passive

IRIG-B TIME SYNCHRONIZATION INPUT

Type: Demodulated input (no carrier)

Formats: B000(*) B001, B002 and B003(*)

Level: TTL

Load: 1.5 mA

(*) Signal combinations recognized in accordance with IRIG Standard 200-95

REAL TIME CLOCK

Accuracy: Typical 20 ppm

Backup energy: More than 1 week

POWER SUPPLY

LOW RANGE (LO):

Nominal DC Voltage: 24 to 48 V

Min/Max DC Voltage: 19.2 / 57.6 V

Voltage Loss hold-up time: 24Vdc 30 ms/48Vdc 100ms

HIGH RANGE (HI):

Nominal DC Voltage: 110 to 250 V

Min/Max DC Voltage: 88 / 300 V

Nominal AC Voltage: 120 to 230 V

Min/Max AC Voltage:

- 102 / 250 V
- Voltage Loss hold-up time for 1/2 RACK units
- 200 ms typical, worst case 100 ms without unit reset
- Voltage Loss hold-up time for 1 RACK units worst case 50 ms without unit reset

ALL RANGES:

Power consumption Typical =25 VA, Maximum =45 VA

OUTPUTS

TRIPPING CONTACTS/OUTPUT RELAYS

Permanent current Carry continuous: 16 A

Closing current Make and Carry for 1 second:

60 A during 1 second

Opening current: 0.3 A with L/R = 40 ms at 125 Vdc

0.25 A with L/R = 40 ms at 250 Vdc

REMOTE OUTPUTS

Standard output points: 32

User output points: 32

COMMUNICATIONS

FRONT PORT (COM2):

Type: USB

Baud Rate: 300, 600, 1200, 2400, 4800, 9600, 38400, 57600 and 115200 bauds

Default baud rate: 19200 bauds

Protocol: ModBus RTU / DNP 3.0

ASYNCHRONOUS REAR PORT (COM1):

Type: RS485 port

PROTOCOLS: DNP on COM1

Serial Modbus on COM1

ETHERNET PORT (COM3):

Type:

Model G: 1588, 10/100 Base TX* + 100 Base TX

Model H: 1588, 10/100 Base TX* + 100 Base FX

Model J: 1 PRP, 1588, 10/100 Base TX* + Redundant 100 Base FX

Model K: PRP, HSR, RSTP, 1588, 10/100 Base TX* + Redundant 100 Base FX

Model L: PRP, 1588, 10/100 Base TX + Redundant 100 Base TX

Model M: PRP, HSR, RSTP, 1588, 10/100 Base TX + Redundant 100 Base TX

Protocols: ModBus TCP/IP
DNP over TCP/IP and UDP/IP
IEC 60870-5-104
IEC61850 Edition 2
IEEE1588
IEC62439-3 Clause 4 (PRP)
IEC62439-3 Clause 5 (HSR)
IEEE 802.1D (RSTP) Http, ftp, tftp (allow the use of a standard Internet browser)

MECHANICAL CHARACTERISTICS

Protection class IP52 (according to IEC 529)

Metallic package in a full 19" rack and 6 Units high

Metallic package in 1/2 19" rack 6 units high

CONTROL

Graphical display: English, French, Spanish, Turkish.

Basic display: English, French, Spanish, Turkish.

PACKAGING

Approximate weight 19":

Net: 19.8 lbs (9 kg)

Ship: 22 lbs (10 kg)

Approximate weight 1/2 19":

Net: 11 lbs (5 kg)

Ship: 13.2 lbs (6 kg)

ENVIRONMENTAL

Temperature:

Storage: -40 to +80° C

Operation: -10 to +60° C

Humidity: Up to 95% without condensing

APPROVALS

CE: Conforms to EN/IEC 60255, 61010

TYPE TEST			
CATEGORY	TEST	REFERENCE STANDARD	TEST LEVEL
SAFETY	Dielectric voltage withstand	IEC60255-27	2 KV / 2.3 KV
	Impulse voltage withstand	IEC60255-27	5 KV
	Insulation resistance	IEC60255-27	500 V (test level)
EMC	Electrostatic Discharge Immunity	IEC60255-26/ IEC61000-4-2	Level 4
	Radiated RF Electromagnetic Field Immunity	IEC60255-26/ IEC61000-4-3	Level 3
	Surge Immunity	IEC60255-26/ IEC61000-4-5	Zone A
	Conducted RF Immunity	IEC60255-26/ IEC61000-4-6	Level 3
	Power magnetic Immunity	IEC60255-26/ IEC61000-4-8	Level 5
	Power Frequency Immunity	IEC60255-26/ IEC61000-4-16	Zone A
	Damped Oscillatory Wave Immunity	IEC60255-26/ IEC61000-4-18	2.5 KV Common Mode/1 KV Diff.Mode
	Voltage Dips & Interruptions	IEC60255-26/ IEC61000-4-11 IEC61000-4-29	Levels based on IEC61000-4-11 & IEC61000-4-29
	Ripple on DC	IEC60255-26/ IEC61000-4-17	15% Rated DC value
	Radiated & Conducted Emissions	IEC60255-26/ CISPR11/CISPR22	Class A

CATEGORY	TEST	REFERENCE STANDARD	TEST LEVEL
MECHANICAL	Sinusoidal Vibration	IEC60255-21-1	Class 1
	Shock & Bump	IEC60255-21-2	Class 1
	Seismic	IEC60255-21-3	Class 2
	Enclosure Protection	IEC60255-27/ IEC60529	IP52
CLIMATIC	Cold test (storage)	IEC60068-2-1	-40°C @ 16 hrs
	Cold test (operational)	IEC60068-2-1	-20°C @ 16 hrs
	Dry heat test (storage)	IEC60068-2-2	85°C @ 16 hrs
	Dry heat test (operational)	IEC60068-2-2	60°C @ 16 hrs
	Change of Temperature	IEC60068-2-14	5 cycles (3+3) -20°C/60°C
	Damp Heat Humidity Cyclic	IEC60068-2-30	6 cycles (12+12) 55°C @ 93% R.H.
	Damp Heat steady state	IEC60068-2-78	40°C @ 93% R.H.

Ordering code for C650

C650 *	*	*	*	F	*	G	*	*	*	*	*	E	*	*	*	*	DESCRIPTION
DISPLAY	B M N E C D																Basic Display and Basic Control Functionality.(*) Graphical Display with Standard Symbols and Basic Control Functionality(*) Graphical Display with IEC Symbols and Basic Control Functionality.(*) Basic Display and Enhanced Control Functionality.(*) Graphical Display with Standard Symbols and Enhanced Control Functionality.(*) Graphical Display with IEC Symbols and Enhanced Control Functionality.(*)
FORM FACTOR 19" SERIAL COMMS																	RS485(****) None
FORM FACTOR 1/2 RACK SERIAL COMMS	N F A P G X Y Z C M																Redundant RS485 Redundant plastic fiber optic Redundant glass fiber optic Redundant RS485 + fiber remote CAN bus I/O Redundant plastic fiber optic + fiber remote CAN bus I/O Redundant glass fiber optic + fiber remote CAN bus I/O Cable remote CAN bus I/O
REAR ETHERNET COMMUNICATIONS BOARD 2		G H J K L M															RS485 + cable remote CAN bus I/O 1588, 10/100 Base TX* + 100 Base TX (***) 1588, 10/100 Base TX* + 100 Base FX (***) PRP, 1588, 10/100 Base TX* + Redundant 100 Base FX (***) PRP, HSR, RSTP, 1588, 10/100 Base TX* + Redundant 100 Base FX (***) PRP, 1588, 10/100 Base TX + Redundant 100 Base TX (***) PRP, HSR, RSTP, 1588, 10/100 Base TX + Redundant 100 Base TX (***)
I/O BOARD IN SLOT F				1 2 4 5													16 Digital Inputs + 8 Outputs 8 Digital Inputs + 8 Outputs + 2 Trip Close circuit supervision circuits 32 Digital Inputs
I/O BOARD IN SLOT G						0 1 4 5											16 Digital Inputs + 8 Analog Inputs None 16 Inputs + 8 Outputs 32 Digital Inputs (**) 16 Digital Inputs + 8 Analog Inputs (**) 24-48 Vdc (range 19.2 – 57.6) 110-250 Vdc (range 88 – 300),120-230 Vac (range 96 – 250) Redundant L Redundant H
AUXILIARY VOLTAGE							LO HI LOR HIR										English/English French/English Spanish/English Turkish/English
LANGUAGE								- F S T									Modbus RTU, TCP/IP, DNP 3.0 Level 2, IEC 60870-5-104 IEC 61850 Edition 2, Modbus RTU & TCP/IP, DNP 3.0 Level 2, IEC 60870-5-104
PROTOCOL									6								Without Harsh (Chemical) Environment Conformal Coating Harsh (Chemical) Environment Conformal Coating
ENVIRONMENTAL PROTECTION										H							Enhanced Display with front USB port
ENHANCED DISPLAY											E						None
I/O BOARD IN SLOT H (ONLY FOR FORM FACTOR 19")												0 1 4 5					16 Digital Inputs + 8 Outputs 32 Digital Inputs 16 Digital Inputs + 8 Analog Inputs (**)
I/O Board in slot J (only for FORM FACTOR 19")													0 1 4 5				None 16 Inputs + 8 Outputs 32 Digital Inputs (**) 16 Digital Inputs + 8 Analog Inputs (**)
I/O Board in slot 2H (only for FORM FACTOR 19")														0 1 4 5			None 16 Digital Inputs + 8 Outputs 32 Digital Inputs 16 Digital Inputs + 8 Analog Inputs (**)
I/O Board in slot 2J (only for FORM FACTOR 19")															0 1 4 5		None 16 Inputs + 8 Outputs 32 Digital Inputs (**) 16 Digital Inputs + 8 Analog Inputs (**)

Notes:

(*) Control functionality description for basic and enhanced models. See table below

C650 Enhanced includes:
25 Synchrocheck
79 Recloser
Metering

(**) The number selected for option G, J and 2J must be equal or higher than the number selected for options F, H and 2H respectively for models including boards 4 and 5; e.g. C650***F5G1HI6E2154 is not valid whereas C650***F1G5HI6E1245 is correct.

(***) Advanced functionalities:

- G & H: IEEE1588 Precision Time Protocol (PTP), 61850 Edition 2.0.
- J & L: Parallel Redundancy Port (PRP) IEEE1588 Precision Time Protocol (PTP), 61850 Edition 2.0.
- K & M: High-Availability Seamless Redundancy (HSR), Rapid Spanning Tree Protocol (RSTP), Parallel Redundancy Port (PRP) IEEE1588 Precision Time Protocol (PTC), 61850 Edition 2.0.

(****) Option ""N"" for Rear Serial Communication board means a casing of 19"" (rack). This model allows up to 6 IOboards in the same casing.

Please refer to the online store for valid configurations.

Related Products / Accessories

MultiSync 100 - GPS Clock	MultiSync100-P
Remote CAN Bus IO Module	CIO

Toll Free: +1 877-605-6777

Direct: +1 678-844-6777

GEDigitalEnergy.com

IEC is a registered trademark of Commission Electrotechnique Internationale. IEEE is a registered trademark of the Institute of Electrical Electronics Engineers, Inc. Modbus is a registered trademark of Schneider Automation. ANSI is a registered trademark of American National Standards Institute, Incorporated.

GE, the GE monogram, Multilin, EnerVista and MultiSync are trademarks of General Electric Company.

GE reserves the right to make changes to specifications of products described at any time without notice and without obligation to notify any person of such changes.

Copyright 2015, General Electric Company. All Rights Reserved.

GEA-12946(E)
English
151019



imagination at work