

# Multilin 750/760

## Feeder protection system

The 750/760 Feeder Protection System is a digital relay intended for the management and primary protection and control of distribution feeders. This easy to use relay provides comprehensive protection functions for feeders and back up protection for bus, transformers and transmission lines in a draw out construction and at a reduced product life cycle cost.

### Key Benefits

- Easy to use Feeder Protection System supported by industry leading suite of software tools
- Accurate built-in metering functions - Eliminates auxiliary metering devices and reduces cost
- Improve uptime of auxiliary equipment - I/O monitoring
- Reduce troubleshooting time and maintenance costs - IRIG-B time synchronization, event reports, waveform capture, data logger
- Minimize replacement time - Draw-out construction
- Simplify testing - Built in simulation features
- Cost effective access to information. Supports industry protocols such as DNP & Modbus. Includes an optional 10MB Ethernet port for system integration
- Complete asset monitoring - Analog I/O, Full metering including demand & energy
- Leading edge technology - Flash memory for product field upgrade
- Extended life - Optional conformal coating for chemically corrosive and humid environments
- Globally accepted ensuring adherence to international codes and standards

### Applications

- Primary protection and control for distribution feeders on solidly grounded, high impedance grounded or resonant (Peterson Coil) grounded systems
- Bus blocking/Interlocking schemes
- High-speed fault detection for arc flash mitigation
- Throw over schemes (bus transfer scheme applications)
- Load shedding schemes based on voltage and frequency elements
- Back-up protection for transmission lines, feeders and transformers
- Distributed Generation (DG) interconnect protection



## Protection and Control

- Directional time, instantaneous phase & ground overcurrent protection
- Directional sensitive ground and Restricted Earth Fault protection
- Reverse power protection
- Synchro Check - V, f, Hz, & dead-source
- Automatic bus transfer or manual control
- 4 shot recloser (760 only)

## Communications

- Networking interfaces - 10Mbps Ethernet, RS232, RS485 and RS422 ports
- Ethernet port, 10Mbps
- Multiple protocols - ModBus™ RTU, TCP/IP, DNP 3.0 Level 2

## Monitoring & Metering

- Metering - current, voltage, sequence components, power, energy, voltage
- Breaker operation & trip failure
- Total breaker arcing current
- Ambient temperature /analog transducer input
- Oscillography & Data Logger - 10 records up to 32 power cycles
- Simulation mode and playback capability

## EnerVista Software

- State of the art software for configuration and commissioning Multilin products
- Document and software archiving toolset to ensure reference material and device utilities are up-to-date
- EnerVista™ Integrator providing easy integration of data in the 750/760 into new or existing monitoring and control systems



## Protection and Control

The 750/760 Feeder Protection System is a digital relay intended for the management and primary protection and control of distribution feeders. This easy to use relay provides comprehensive protection functions for feeders and back up protection for bus, transformers and transmission lines at a reduced product life cycle cost.

### Time & Instantaneous Overcurrent

The 750/760 has two phase TOC elements with level detectors for each phase. The 750/760 also has two overcurrent elements most commonly used for primary and back up protection. Each TOC element has the following programmable characteristics:

- Pickup current level for trip, alarm, or control
- Choice of 15 curve shapes (including FlexCurves) and curve multipliers
- Instantaneous or linear reset time characteristic
- Voltage restraint

ANSI	Extremely Inverse
	Very Inverse
	Normally Inverse
	Moderately Inverse
	Definite Time
IEC	Curve A (BS142)
	Curve B (BS142)
	Curve C (BS142)
IAC	Short Inverse
	Extreme Inverse
	Very Inverse
	Inverse
	Short Inverse
Custom	FlexCurve™ A
	FlexCurve™ B

Standard and Flex Curves

The 750/760 has two phase IOC elements with level detectors for each phase. Each IOC element has a programmable pickup current, a time delay during which current must exceed the pickup for operation, and the minimum number of phases required for operation.

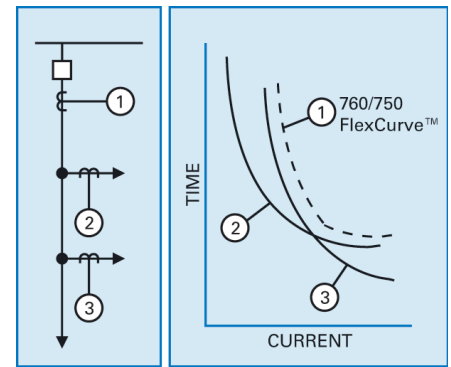

Typical application of FlexCurves™

### Ground overcurrent protection

Solidly grounded and low impedance grounded distribution systems requiring fast clearing of ground faults to limit equipment damage. The following functions are incorporated in the 750/760 to provide ground fault protection

- Neutral IOC and TOC
- Ground IOC and TOC

750/760 allows directional elements to be used to supervise the ground overcurrent protection

## Functional Block Diagram

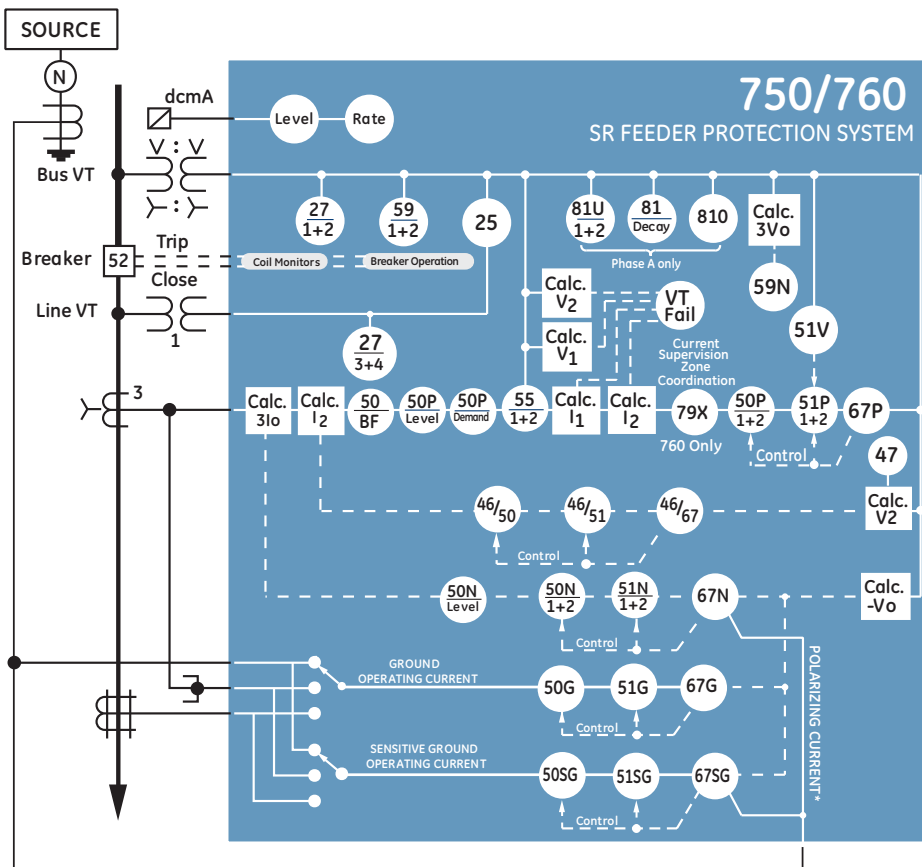

\* POLARIZING CURRENT AND GND CURRENT ARE MUTUALLY EXCLUSIVE SINCE BOTH USE THE SAME RELAY CT INPUT TERMINALS

## ANSI Device Numbers & Functions

Device Number	Function
25	Synchronism Check
27	Bus/Line Undervoltage
32	Reverse Power
46/50	Negative Sequence Instantaneous Overcurrent
46/51	Negative Sequence Timed Overcurrent
46/67	Negative Sequence Directional Overcurrent
50	Breaker Failure
50N	Neutral Instantaneous Overcurrent
50P	Phase Instantaneous Overcurrent
50G	Ground Instantaneous Overcurrent
50SG	Sensitive Ground Instantaneous Overcurrent
51N	Neutral Time Overcurrent
51P	Phase Time Overcurrent
51G	Ground Time Overcurrent
51SG	Sensitive Ground Time Overcurrent
55	Power Factor
59	Overvoltage
59N	Neutral Overvoltage
59P	Phase Overvoltage
67N	Neutral Directional Overcurrent
67P	Phase Directional Overcurrent
67G	Ground Directional Overcurrent
67SG	Sensitive Ground Directional Overcurrent
81U/O	Under/Over Frequency
81	Frequency Decay

elements. This means the 750/760 can be used to provide sensitive tripping for faults in one direction. Typical applications for directional overcurrent include:

- Isolation of the faulted feeder in ring bus or parallel feeder arrangements.
- Prevention of back-feeding utility source fault from industrial plant generators
- Sensitive hi-speed ground protection of transformers

Sensitive ground and Restricted Earth Fault (REF) protection

Sensitive ground and RGF protection features provide sensitive detection of ground faults. Sensitive ground fault protection includes:

- Instantaneous (50N) & Tim (51N) - 2 levels
- Directional supervision allows to discriminate between forward and reverse faults.
- Dual polarization (current & voltage) provides max security and reliability

750/ 760 employed to provide transformer back up protection (grounded wye windings and autotransformers) using the RGF feature.

### Voltage Protection

Overvoltage/Undervoltage protection features can cause a trip or generate an alarm when the voltage exceeds a specified voltage setting for a specified time. Voltage protection includes a negative sequence voltage element to detect abnormal system unbalance conditions, and a neutral displacement voltage element using the calculated zero sequence voltage (3V0) to detect ground faults.

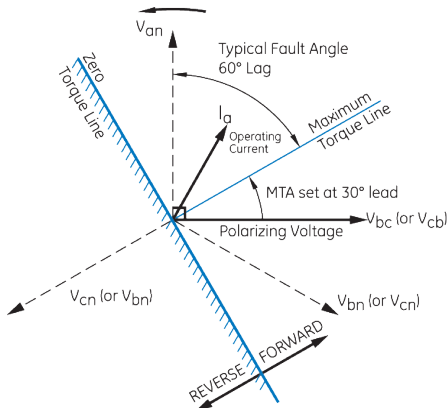

Phase directional (for phase A).

## Protection/Control

Bus/Line Undervoltage	●	●	●	●
Negative Sequence Voltage	●	●	●	●
Phase/Neutral/Gnd/Neg Seq/Sens Gnd IOC	●	●	●	●
Phase/Neutral/Gnd/Neg Seq/Sens Gnd TOC	●	●	●	●
Bus Overvoltage/Neutral Displacement	●	●	●	●
Phase/Neutral/Neg Seq/Sens Gnd/Gnd Directional Control			●	●
Bus Underfrequency/Rate of Change			●	●
Undervoltage Automatic Restoration	●	●	●	●
Underfrequency Automatic Restoration	●	●	●	●
Breaker Failure with Current Superv.	●	●	●	●
Bus Transfer			●	
Programmable Logic Inputs	●	●	●	●
Multiple Setpoint Groups	●	●	●	●

## Monitoring/Control

Synchronism Check			●	
Phase/Neutral Current Level	●	●	●	●
Power Factor	●	●		
Autoreclose (760 only)			●	●
Overfrequency				●
Breaker Open/Close	●	●	●	●
Manual Close Feature Blocking	●	●	●	
Cold Load Pickup Feature Blocking			●	●
Breaker Operation Failure	●	●	●	●
Trip/Close Circuit Failure	●	●	●	●
Total Breaker Arcing Current	●	●	●	●
VT Failure	●	●	●	●
Demand (A, MW, Mvar, MVA)	●	●	●	●
Analog Input	●	●	●	●
Event Recording	●	●	●	●
Analog Output	●	●	●	●
Fault Locator			●	●
Trip Counter	●	●	●	●

FEEDER	Capacitor	Radial	Two-ended	BUS	Backup	Transfer	TRANSFORMER	Backup	LINE	Backup
--------	-----------	--------	-----------	-----	--------	----------	-------------	--------	------	--------

Synchronism Check										●
Phase/Neutral Current Level	●	●	●	●	●	●	●	●	●	●
Power Factor	●	●								
Autoreclose (760 only)			●	●						●
Overfrequency										●
Breaker Open/Close	●	●	●	●	●	●	●	●	●	●
Manual Close Feature Blocking	●	●	●	●	●		●	●		
Cold Load Pickup Feature Blocking			●	●			●	●		
Breaker Operation Failure	●	●	●	●	●	●	●	●	●	●
Trip/Close Circuit Failure	●	●	●	●	●	●	●	●	●	●
Total Breaker Arcing Current	●	●	●	●	●	●	●	●	●	●
VT Failure	●	●	●						●	●
Demand (A, MW, Mvar, MVA)	●	●	●	●	●	●	●	●	●	●
Analog Input	●	●	●	●	●	●	●	●	●	●
Event Recording	●	●	●	●	●	●	●	●	●	●
Analog Output	●	●	●	●	●	●	●	●	●	●
Fault Locator				●	●				●	●
Trip Counter	●	●	●	●	●	●	●	●	●	●

### Frequency Protection

750/760 provides functionality to improve network (grid) stability using voltage or frequency based techniques. Also allows to provide back up protection and trip breakers directly when protecting generators and other frequency sensitive power equipment.

- 2 Under-frequency elements (81U)
- 2 Over-frequency elements (81O)
- Frequency decay: 4 df/dt elements (59/81)
- 2 Undervoltage elements

### Reverse power detection

750/760 relay allows to trip or alarm when power flows against the intended direction. In systems having in-plant generation parallel to the utility supply, detection of power flow toward the utility is necessary. For such applications, 750/760 eliminates requirement for separate device to detect power flow direction and reduces overall cost. This feature can also be used to detect motoring power into the generator.

## Synchronism Check

Breaker closing can be supervised by  $\Delta V$ ,

$\Delta f$  and  $\Delta Hz$  setpoints. Dead-source alternatives are provided.

## Cold Load Pickup Control

This function allows automatic or manual blocking or raising of trip settings for a period after the breaker is closed. Built-in scheme available to perform main-tie-main transfer using a set of three relays, two on incoming and one on a normally open bus tie breaker. This scheme uses "open before close" sequence for safe operation.

## Manual Close Control

After the breaker is closed manually, the relay can block any IOC element or raise the pickup value of any TOC element, each for a programmable time delay, after which normal operation is restored.

## Bus Transfer Scheme

A set of three relays, two on incoming and one on a normally open bus tie breaker can perform transfer on loss-of-source.

## Recloser (760 Only)

Autoreclosing can be initiated externally or from an overcurrent protection. Up to four reclose operations are possible, each with a programmable dead time. For each reclose shot, the relay can be programmed to block any IOC element, and to adjust the curve characteristics of any TOC element. The number of shots can be reduced by high currents.

## Equipment Management

The following comprehensive features in the relay allows to manage the primary breaker:

- Trip counter to keep track of number of operations
- Per-phase breaker contact wear calculations for maintenance
- Breaker failure detection
- Trip coil monitoring

## Monitoring and Metering

The 750/760 features advanced monitoring and metering functions which include:

### Fault Locator

The relay uses captured data to calculate the type, distance to and the impedance of the fault. Records of the last 10 faults are stored.

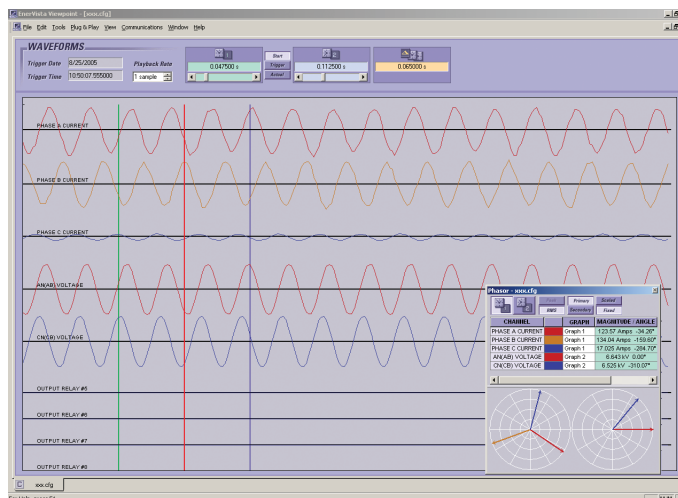

The 750/760 saves up to 256 power frequency cycles of waveform data

## Breaker Conditions

The relay calculates the per-phase wear on the breaker contacts to establish a threshold. When the breaker maintenance threshold is exceeded the relay can trigger an alarm. An alarm is also generated if the relay detects that the supervisory trickle current is not present. A failure to respond to an open or close signal in a programmed time can be used to generate an alarm.

## VT Failure

The VT failure feature monitors each phase of input voltage, generating an alarm and sending the programmed output signals when a failure is detected.

## Power Factor

Two independent elements monitor power factor, each with programmable pickup, dropout and time delay.

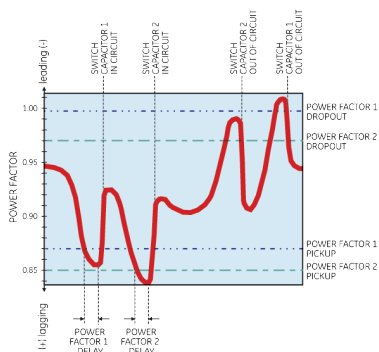

By monitoring the power factor the 750/760 can help minimize both costs and voltage excursions.

## Analog Input

Any external quantity may be monitored via an auxiliary current input. Two analog input level monitoring elements and two rate-of-change elements are available. When the measured quantity exceeds the pickup level, the relay can trigger an alarm or signal an output.

## Event Recording

The relay captures and stores the last 256 events, recording the time, date, cause, and system parameters. Events may be recorded selectively by category, so that only events of interest are recorded.

## Oscillography

A block of configurable volatile memory can be used for recording samples of the AC input voltages and current, and the status of logic inputs and output relays. This memory can be configured between the ranges of two to 16 blocks with 16 to 256 power frequency cycles of data respectively. The amount of pre-event data recorded is set by the user. Trace memory recording can be triggered by operation of selected features or logic inputs.

## Trip Counter

The number of breaker trip operations is recorded, and can be displayed for statistical purposes (useful for units without operation counters).

## Metering

The 750/760 performs accurate measurement of the following:

- Actual V, A, Hz, W, Wh, var, varh, VA-PF
- Watthour cost
- Phasor presentation of V and I
- Symmetrical components of V and I
- Line (synchronous) voltage: RMS voltage, frequency, and differentials
- Percent of load-to-trip
- Analog input
- Running and maximum demand: A, MW, MVAR, MVA

Setpoints allow the user to simulate three common electrical utility demand measuring techniques.

## Data Logging

A configurable memory block can record eight channels of any measured or calculated parameter. In continuous mode, this feature can be programmed to capture from 136 seconds of data per cycle to 48 weeks of data per hour.

## Simulation

The relay provides a powerful simulation feature for testing the functionality of the relay in response to programmed conditions. System parameters are entered as setpoints. Pre-fault, fault, and post-fault conditions can be simulated to exercise relay features.

## Logic Inputs

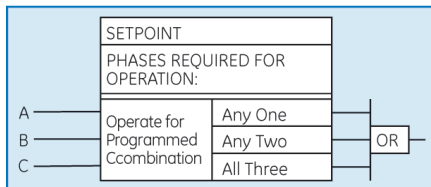

Setpoints block diagram.

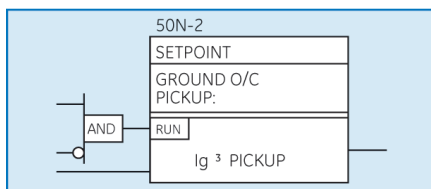

Level detectors block diagram.

The relay has 14 contact and 20 serial inputs which can be programmed to perform any of 60 predefined functions, including remote tripping, resetting, feature blocking, and more.

## Inputs and Outputs

The 750/760 features user-configurable inputs and outputs:

### Outputs

The 750/760 has eight electromechanical relay outputs.

- Two are factory programmed for breaker control
- Five can be configured to operate as either failsafe or non-failsafe, and either latching, self-resetting, or pulsed; these relays can be programmed to be operated by any feature
- One of the relays is factory programmed as a fail safe internal failure alarm relay

The 750/760 has one high-speed SCR solid state output.

The 750/760 has eight analog output channels. Any of 31 measured parameters can be selected to drive these outputs.

### IRIG-B Input

An IRIG-B input allows time synchronization using a satellite signal.

## Communications

The 750/760 is equipped with three standard serial communications ports, one RS232 located in the front panel, and two RS485/RS422 in the rear of the relay. A rear Ethernet port is also available as an optional feature. The front panel port allows easy local computer access. The rear ports provide remote communications or connection to a DCS, SCADA, or PLC. The baud rate of all the serial ports is variable from 300 to 19,200 bps. The optional Ethernet port can be used to connect the 750/760 to 10 Mbps Ethernet networks. The 750/760 supports ModBus® RTU, DNP3.0 Level 2, and ModBus RTU TCP/IP protocols.

The three serial ports support ModBus RTU protocol, while any one of the two rear ports but not both can be configured to support DNP 3.0 Level 2. The optional Ethernet port supports ModBus RTU via TCP/IP protocol. The communication system of the 750/760 is designed to allow simultaneous communication via all ports.

Using Ethernet as the physical media to integrate the 750/760 to Local or Wide Area Networks, replaces a multidrop-wired network (e.g., serial Modbus®), and eliminates expensive leased or dial-up connections, reducing monthly operating costs.

## Access Security

The 750/760 can be protected against unauthorized setpoint changes. A key switch may be installed on the rear terminals to allow setpoint changes from the front panel. An optional passcode restricts setpoint changes from both the front panel and ports.

## EnerVista Software

The EnerVista™ Suite is an industry-leading set of software programs that simplifies every aspect of using the 750/760 relay. The EnerVista™ suite provides all the tools to monitor the status of your protected asset, maintain the relay, and integrate information measured by the 750 into DCS or SCADA monitoring systems. Convenient COMTRADE and Sequence of Events viewers are an integral part of the 750 Setup software included with every 750 relay, to carry out postmortem event analysis to ensure proper protection system operation.

### EnerVista Launchpad

EnerVista™ Launchpad is a powerful software package that provides users with all of the setup and support tools needed for configuring and maintaining Multilin products. The setup software within Launchpad allows configuring devices in real-time by using serial, Ethernet, or modem connections, or offline by creating setting files to be sent to devices at a later time.

Included in Launchpad is a document archiving and management system that ensures critical documentation is up-to-date and available when needed. Documents made available include:

- Manuals
- Application Notes
- Guideform Specifications
- Brochures
- Wiring Diagrams
- FAQ's
- Service Bulletins



## Viewpoint Monitoring

Viewpoint Monitoring is a simple-to-use and full-featured monitoring and data recording software package for small systems. Viewpoint Monitoring provides a complete HMI package with the following functionality:

- Plug-&-Play Device Monitoring
- System Single-Line Monitoring & Control
- Annunciator Alarm Screens
- Trending Reports
- Automatic Event Retrieval
- Automatic Waveform Retrieval

## Retrofit Existing Multilin SR 750 Devices in Minutes

Traditionally, retrofitting or upgrading an existing relay has been a challenging and time consuming task often requiring re-engineering, panel modifications, and re-wiring. The Multilin 8 Series Retrofit Kit provides a quick, 3-step solution to upgrade previously installed Multilin SR 750/760 protection relays, reducing upgrade costs.

With the new 8 Series Retrofit Kit, users are able to install a new 850 Feeder Management System without modifying existing panel or switchgear cutouts, re-wiring, or need for drawing changes and re-engineering time and cost.

With this three-step process, operators are able to upgrade existing SR relays in as fast as 21 minutes, simplifying maintenance procedures and reducing system downtime.



EnerVista 8 Series Setup Software provides automated setting file conversion with graphical report to quickly and easily verify settings and identify any specific settings that may need attention.

Simply remove the 4 existing terminal blocks and then remove the SR chassis from the panel. No need to disconnect any of the field wiring.

Insert the new 8 Series Retrofit chassis into the switchgear and simply plug-in the old terminal blocks - there is need to make any cut-out modifications or push and pull cables.

The 8 Series Retrofit Kit comes factory assembled and tested as a complete unit with the 8 Series protection device and includes replacement hardware (terminal blocks and screws) if the existing hardware is significantly aged or damaged.

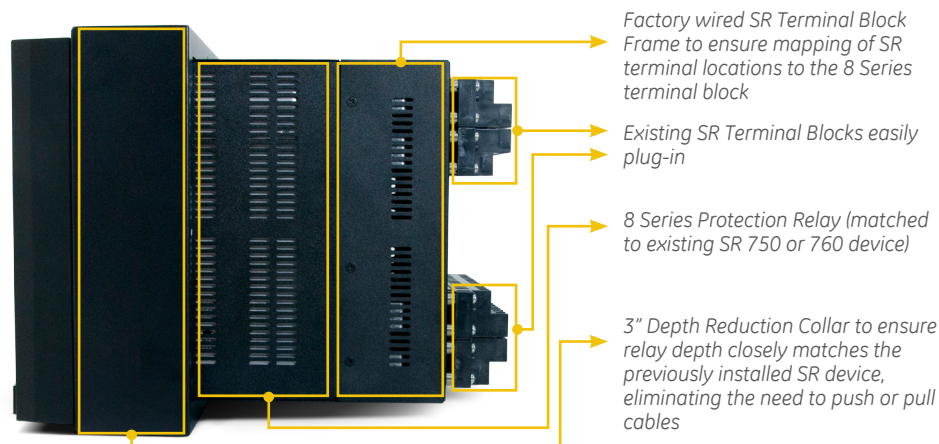

## Explore in Detail

visit us online to explore the SR to 8 Series retrofit kit in detail using our interactive app. [www.GEGridSolutions.com/8SeriesRetrofitKit](http://www.GEGridSolutions.com/8SeriesRetrofitKit)



Multilin 8 Series Retrofit

# Typical Wiring

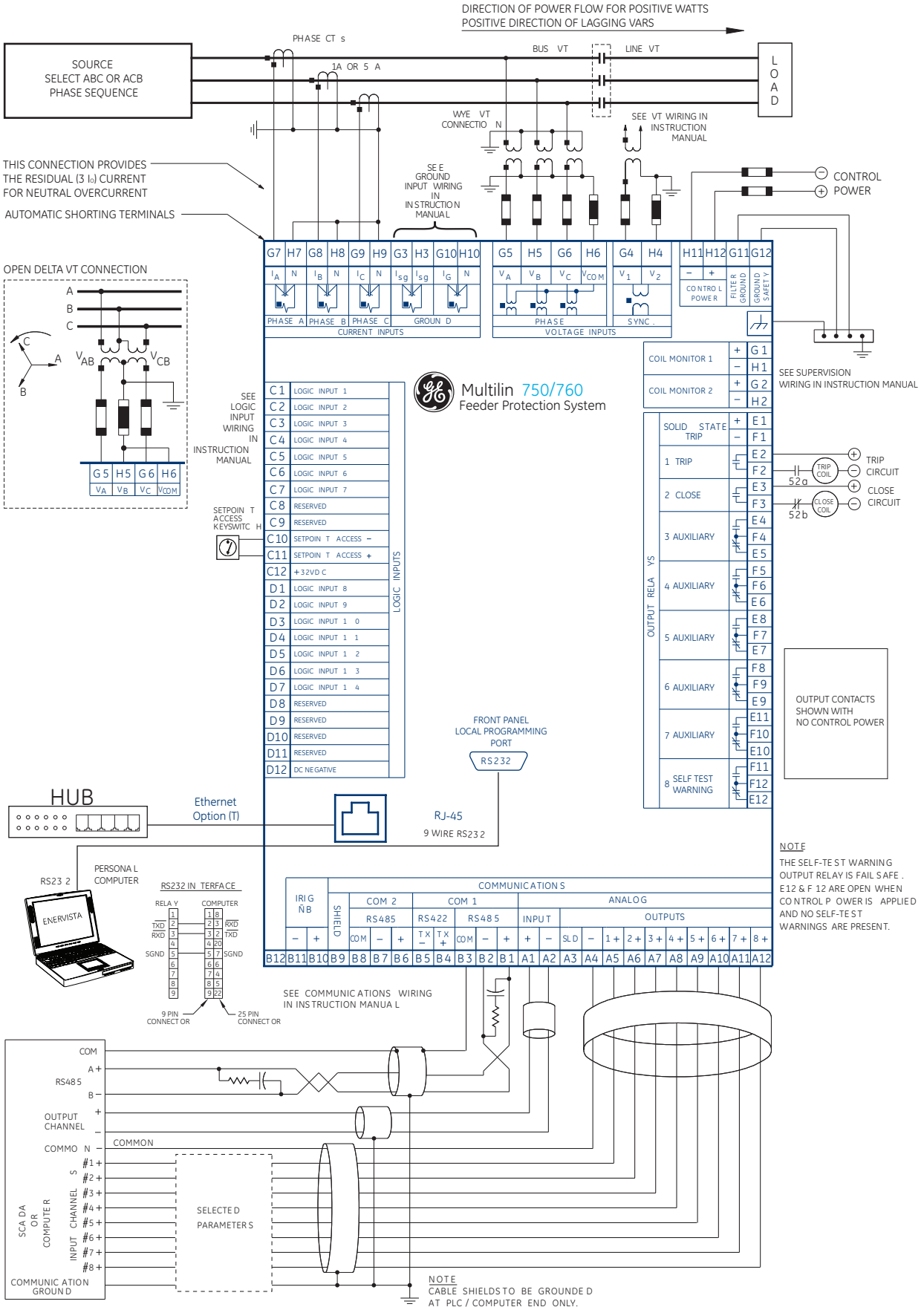

# Technical Specifications

## PROTECTION

### PHASE/NEUTRAL/GROUND/NEGATIVE SEQUENCE TIME OVERCURRENT PROTECTION

**Pickup level:** 0.05 to 20.00 in steps of 0.01 x CT  
**Dropout level:** 97 to 98% of Pickup  
**Curve shape:** ANSI extremely/very/moderately/ normally inverse  
 Definite time (0.1 s base curve)  
 IEC curve A/B/C and short  
 FlexCurve™ A/B (programmable curves)  
 IAC extreme/very/inverse/short  
**Curve multiplier:** 0.00 to 100.00 in steps of 0.01  
**Reset type:** Instantaneous/linear  
**Level accuracy:** Per current input (I<sub>2</sub> is 3 x input error)  
**Timing accuracy:** at 1.03 x PU: ±3% of trip time or ±40 ms (whichever is greater)

### SENSITIVE GROUND TIME OVERCURRENT PROTECTION

**Pickup level:** 0.005 to 1.000 in steps of 0.001 x CT  
**Dropout level:** 97 to 98% of pickup  
**Curve shape:** ANSI extremely/very/moderately/ normally inverse  
 Definite time (0.1 s base curve)  
 IEC Curve A/B/C and short  
 FlexCurve™ A/B (programmable curves) IAC extreme/very/inverse/short  
**Curve multiplier:** 0.00 to 100.00 in steps of 0.01  
**Reset type:** Instantaneous/linear  
**Level accuracy:** Per current input (I<sub>2</sub> is 3 x input error)  
**Timing accuracy:** at 1.03 x PU: ±3% of trip time or ±40 ms (whichever is greater)

### PHASE/NEUTRAL/GROUND/NEGATIVE SEQUENCE INSTANTANEOUS OVERCURRENT PROTECTION

**Pickup level:** 0.05 to 20.00 in steps of 0.01 x CT  
**Dropout level:** 97 to 98% of pickup  
**Time delay:** 0.00 to 600.00 in steps of 0.01 s  
**Level accuracy:** Per phase/neutral/ground current input (I<sub>2</sub> is 3 x phase input error)  
**Timing accuracy:**  
 At 0 ms time delay (no intentional delay):  
 Relay contacts = 50 ms max  
 solid state output = 45 ms max  
 At non-zero time delay:  
 Delay accuracy = 0 to +20 ms  
 Any one/any two/all three (programmable)  
 phases have to operate for output (not for I<sub>2</sub>)  
**Phases:**

### PHASE DIRECTIONAL

**Relay Connection:** 90° (quadrature)  
**Polarizing Voltage:** V<sub>bc</sub> (phase A), V<sub>ca</sub> (phase B), V<sub>ab</sub> (phase C)  
**MTA:** 0 to 359° in steps of 1  
**Angle Accuracy:** ±2°  
**Operation Delay:** 25 to 40 ms

### NEUTRAL DIRECTIONAL

**NOTE:** Polarized by voltage, current, or both voltage and current. For voltage element polarizing, the source VTs must be connected in Wye. **Polarizing voltage:** V<sub>0</sub>  
**Polarizing current:** I<sub>g</sub> MTA:  
 0 to 359° in steps of 1  
**Angle accuracy:** ±2°  
**Operation delay:** 25 to 40 ms

### GROUND / SENSITIVE GROUND DIRECTIONAL

**NOTE:** Polarized by voltage, current, or both voltage and current. For voltage element polarizing, the source VTs must be connected in Wye.

**Polarizing voltage:** -V<sub>0</sub>  
**Polarizing current:** I<sub>g</sub>  
**MTA:** 0 to 359° in steps of 1  
**Angle accuracy:** ±2°  
**Operation delay:** 25 to 40 ms

### BUS UNDERVOLTAGE 1/2 AND LINE UNDERVOLTAGE 3/4

**Minimum voltage:** > programmable threshold from 0.00 to 1.25 x VT in steps of 0.01  
 0.00 to 1.25 in steps of 0.01 x VT  
**Pickup level:** 102 to 103% of pickup  
**Dropout level:** Definite time or inverse time  
**Curve:** 0.0 to 6000.0 in steps of 0.1 s  
**Time delay:** Any one/any two/all three (programmed)  
**Phases:** to operate for output (bus undervoltage only)  
**Level accuracy:** Per voltage input  
**Timing accuracy:** ±100 ms

### OVERVOLTAGE 1/2

**Pickup level:** 0.00 to 1.25 in steps of 0.01 x VT  
**Dropout level:** 97 to 98% of pickup  
**Time delay:** 0.0 to 6000.0 in steps of 0.1 s (definite time)  
**Phases:** Any one/any two/all three (programmable)  
 phases have to operate for output  
**Level accuracy:** Per voltage input  
**Timing accuracy:** ±100 ms

## PROTECTION

### NEGATIVE SEQUENCE VOLTAGE

**Pickup level:** 0.00 to 1.25 in steps of 0.01 x VT  
**Dropout level:** 97 to 98% of pickup  
**Time delay:** 0.0 to 6000.0 in steps of 0.1 (definite or inverse time)  
**Level accuracy:** 3 x voltage input error  
**Timing accuracy:** ±100 ms

### UNDERFREQUENCY 1/2

**Minimum voltage:** 0.00 to 1.25 in steps of 0.01 x VT in phase A  
**Pickup level:** 20.00 to 65.00 in steps of 0.01 Hz  
**Dropout level:** Pickup + 0.03 Hz  
**Time delay:** 0.00 to 600.00 in steps of 0.01 s (definite time)  
**Level accuracy:** ±0.02 Hz  
**Timing accuracy:**  
 At 60 Hz: ±25 ms  
 At 50 Hz: ±30 ms

### NEUTRAL DISPLACEMENT

**Pickup level:** 0.00 to 1.25 x VT in steps of 0.01  
**Dropout level:** 97 to 98% of pickup  
**Curves:** ANSI Extremely/ Very/ Moderately/ Normally Inverse, Definite Time (0.1 s base curve), IEC Curve A/B/C and Short, FlexCurve, A/B (programmable curves), IAC Extreme/ Very/ Inverse/Short  
**Curve multiplier:** 0 to 100.00 in steps of 0.01  
**Reset type:** Instantaneous/Linear  
**Level accuracy:** 3 x voltage input error  
**Timing accuracy:** ±50 ms

### REVERSE POWER (IF ENABLED)

**Pickup level:** 0.015 to 0.600 x rated power  
**Dropout level:** 94 to 95% of pickup  
**Reset time:** less than 100 ms  
**Level accuracy:** see 3 φ Real Power metering  
**Time delay:** 0.0 to 6000.0 s in steps of 0.1  
**Timing accuracy:** ±200 ms (includes Reverse Power pickup time)

### BREAKER FAILURE

**Pickup level:** 0.05 to 20.0 x CT in steps of 0.01  
**Dropout level:** 97 to 98% of pickup  
**Time delay:** 0.03 to 1.00 s in steps of 0.1  
**Timing accuracy:** ±20 ms error  
**Level accuracy:** per CT input

## METERING

### CURRENT

**Phasors:** Phase A RMS current  
 Phase B RMS current  
 Phase C RMS current  
**% of load-to-trip accuracy:** ±0.5% of fullscale

### VOLTAGE

**Phasors:** Phase A-N (A-B) voltage  
 Phase B-N (B-C) voltage  
 Phase C-N (C-A) voltage  
**Accuracy:** ±0.25% of full scale

### FREQUENCY

**Measured:** A-N (A-B) bus and line voltage  
 16 to 65 Hz  
**Accuracy:** ±0.02 Hz

### SYMMETRICAL COMPONENTS

**Current level accuracy:** ±1.5% of full scale  
**Voltage level accuracy:** ±0.75% of full scale  
**Current and voltage angle accuracy:** ±2°

### 3 φ POWER FACTOR

**Range:** 0.00 Lag to 1.00 to 0.00 Lead  
**Accuracy:** ±0.02

### 3 φ REAL POWER

**Range:** -3000.0 to 3000.0 MW  
**Accuracy:** ±1% of full scale

### 3 φ REACTIVE POWER

**Range:** -3000.0 to 3000.0 Mvar  
**Accuracy:** ±1% of full scale

### 3 φ APPARENT POWER

**Range:** -3000.0 to 3000.0 MVA  
**Accuracy:** ±1% of full scale

### WATT-HOURS

**Range:** -2.1 x 108 to 2.1 x 108 MWh  
**Accuracy:** ±2% of full scale per hour

### VAR-HOURS

**Range:** -2.1 x 108 to 2.1 x 108 Mvarh  
**Accuracy:** ±2% of full scale per hour

### DEMAND RANGE

**Phase A/B/C current:** 0 to 65535 A  
**3 φ real power:** -3000.0 to 3000.0 MW  
**3 φ reactive power:** -3000.0 to 3000.0 Mvar  
**3 φ apparent power:** -3000.0 to 3000.0 MVA

### DEMAND MEASUREMENT

**Thermal exponential, 90% response time (programmed):** 5, 10, 15, 20, 30, or 60 min.  
**Block interval / rolling demand, time interval (programmed):** 5, 10, 15, 20, 30, or 60 min.  
**Accuracy:** ±2% of full scale

## MONITORING

### PHASE/NEUTRAL CURRENT

**Pickup level:** 0.05 to 20.00 x CT in steps of 0.01  
**Dropout level:** 97 to 98% of pickup  
**Time delay:** 0 to 6000.0 s in steps of 1 (Definite Time)  
**Level accuracy:** per current input  
**Timing Accuracy:** ±100 ms

### POWER FACTOR

**Required voltage:** >30% of nominal in all phases  
**Pickup level:** 0.50 lag to 0.50 lead in steps of 0.01  
**Dropout level:** 0.50 lag to 0.50 lead in steps of 0.01  
**Time delay:** 0 to 6000.0 s in steps of 1 (Definite Time)  
**Level accuracy:** ±0.02  
**Timing Accuracy:** ±100 ms

### ANALOG IN THRESHOLD

**Pickup level:** 0 to 65535 units in steps of 1  
**Dropout level:** 2 to 20% of Pickup (programmable, under/over)  
**Time delay:** 0 to 6000.0 s in steps of 1  
**Level accuracy:** ±1%  
**Timing Accuracy:** ±100 ms

### ANALOG IN RATE

**Pickup level:** -1000 to 1000 mA/hour in steps of 0.1  
**Dropout level:** 97 to 98% of Pickup  
**Time delay:** 0 to 6000.0 s in steps of 1  
**Level accuracy:** ±1%  
**Timing Accuracy:** ±100 ms

### OVERFREQUENCY

**Required voltage:** >30% of nominal, phase A  
**Pickup level:** 20.01 to 65.00 Hz in steps of 0.01  
**Dropout level:** Pickup - 0.03 Hz  
**Time delay:** 0.0 to 6000.0 s in steps of 0.1  
**Level accuracy:** ±0.02 Hz  
**Timing Accuracy:** ±34 ms at 60 Hz; ±40 ms at 50 Hz

### DEMAND

**Demand accuracies are based on less than 2 x CT and 50 to 130 V inputs.**

**Measured values:** Phase A/B/C current (A), 3 φ real power (MW), 3 φ reactive power (Mvar), 3 φ apparent power (MVA)

### Measurement type:

**Thermal Exponential, 90% response time (programmed):** 5, 10, 15, 20, 30, or 60 min.  
**Block Interval / Rolling Demand, time interval (programmed):** 5, 10, 15, 20, 30, or 60 min.

### Block Interval with Start Demand Interval

**Logic Input pulses**  
**Amps pickup level:** 10 to 10000 in steps of 1  
**MW pkp level:** 0.1 to 3000.0 in steps of 0.1  
**Mvar pkp level:** 0.1 to 3000.0 in steps of 0.1  
**MVA pkp level:** 0.1 to 3000.0 in steps of 0.1  
**Level accuracy:** ±2%

### VT FAILURE

Programmable to inhibit features.

### TRIP / CLOSE COIL MONITORS

Detect open trip and close circuits.

### PULSE OUTPUT

Pulse output is 1 second on time and one second off time after the programmed interval.

### LAST TRIP DATA

Records cause of most recent trip, 4 RMS currents, and 3 RMS voltages with a 1 ms time stamp.

### TRIP COUNTERS

Accumulates all ground, sensitive ground, neutral, negative sequence, and phase overcurrent trips.

### EVENT RECORDER (256 EVENTS)

Records event cause, 3-phase current phasors, 1 ground current phasor, sensitive ground current phasors, 3 voltage phasors, system frequency, synchronizing voltage, synchronizing frequency, and analog input level with a 1 ms time stamp.

### WAVEFORM CAPTURE

**Data channels:** 4 currents, 3 voltages, 14 logic input states and 8 output relays  
**Sample rate:** 16 per cycle  
**Trigger source:** Element pickup/trip/dropout, control/alarm event, logic input or manual command  
**Trigger position:** 0 to 100%  
**Storage capacity:** 2 to 16 events with 4096 to 512 samples of data respectively

### DATA LOGGER

**Data channels:** 8 channels; same parameters as for analog outputs available  
**Sample rate:** Per Cycle / Per second / Per Minute / Every 5,10,15, 20, 30, or 60 min  
**Trigger source:** Pickup/trip/dropout, control/alarm event, logic input, manual command, or continuous  
**Trigger position:** 0 to 100%  
**Storage capacity:** 2 to 16 events with 2048 to 256 samples of data respectively (4096 if continuous)



## Technical Specifications (Cont'd)

### INPUTS

#### PHASE CURRENT INPUT

Source CT:	1 to 50000 A primary / 1 or 5 A secondary
Relay input:	1 A or 5 A (specified when ordering)
Burden:	Less than 0.2 VA at 1 or 5 A
Conversion range:	0.01 to 20 x CT (fundamental frequency only)
Accuracy:	at <2 x CT: $\pm 0.5\%$ of 2 x CT at $\geq 2$ x CT: $\pm 1\%$ of 20 x CT
Overload withstand:	1 second @ 80 times rated current continuous @ 3 times rated current
Calculated neutral current errors:	3 x phase inputs

#### GROUND CURRENT INPUT

Source CT:	1 to 50000 A primary / 1 or 5 A secondary
Relay input:	1 A or 5 A (specified when ordering)
Burden:	Less than 0.2 VA at 1 or 5 A
Conversion range:	0.01 to 20 x CT (fundamental frequency only)
Accuracy:	at <2 x CT: $\pm 0.5\%$ of 2 x CT at $\geq 2$ x CT: $\pm 1\%$ of 20 x CT
Overload withstand:	1 second @ 80 times rated current continuous @ 3 times rated current

#### SENSITIVE GROUND CURRENT INPUT

Source CT:	1 to 50000 A primary / 1 or 5 A secondary
Relay input:	1 A or 5 A (specified when ordering)
Burden:	Less than 0.2 VA at 1 or 5 A
Conversion range:	0.005 to 1.000 x CT (fundamental frequency only)
Accuracy:	at <0.1 x CT: $\pm 0.2\%$ of 1 x CT at $\geq 0.1$ x CT: $\pm 1\%$ of 1 x CT
Overload withstand:	1 second @ 80 times rated current continuous @ 3 times rated current

#### BUS AND LINE VOLTAGE INPUTS

Source VT:	0.12 to 600 kV / 50 to 240 V
Source VT ratio:	1 to 5000 in steps of 0.1
Relay input:	50 V to 240 V phase-neutral
Burden:	Less than 0.025 VA at 120 V or >576 K
Max continuous:	273 V phase-neutral (full scale) CT (fundamental frequency only)
Accuracy (0° - 40° C):	$\pm 0.205\%$ of full scale (10 to 130 V) $\pm 0.8\%$ of full scale (130 to 273 V) (for open delta, the calculated phase has errors 2 times those shown above)

#### LOGIC INPUTS

Inputs:	14 contact and / or virtual, 6 virtual only (functions assigned to logic inputs)
Dry contacts:	1000 maximum ON resistance (32 VDC @ 2 mA provided by relay)
Wet contacts:	30 to 300 VDC @ 2.0 mA (external DC voltage only)

#### ANALOG INPUT

Current input:	0 - 1 mA, 0 - 5 mA, 0 - 10 mA, 0 - 20 mA, or 4 - 20 mA (programmable)
Input impedance:	375 $\pm 10\%$
Conversion range:	0 to 21 mA
Accuracy:	$\pm 1\%$ of full scale

#### TRIP AND CLOSE COIL MONITORING INPUTS

Acceptable voltage range:	20 to 250 VDC
Trickle current:	2 mA to 5 mA

#### IRIG-B INPUT

Amplitude-modulated:	2.5 to 6 Vp-p @ 3:1 signal ratio
DC shift:	TTL

### CONTROL

#### UNDERVOLTAGE RESTORATION

Initiated by:	Trip from undervoltage 1, 2, 3 or 4
Minimum voltage level:	0.00 to 1.25 x VT in steps of 0.01
Time delay:	0.1 to 100.0 in steps of 0.1 s
Incomplete sequence time:	1 to 10000 in steps of 1 min.
Phases:	Any one/any two/all three (programmable) phases have to operate for output
Level accuracy:	Per voltage input
Timing accuracy:	$\pm 100$ ms

#### UNDERFREQUENCY RESTORATION

Initiated by:	Trip from underfrequency 1 or 2
Minimum voltage level:	0.00 to 1.25 x VT in steps of 0.01
Minimum frequency level:	20.00 to 60.00 in steps of 0.01 Hz
Time delay:	0.1 to 100.0 in steps of 0.1 s
Incomplete sequence time:	1 to 10000 in steps of 1 min.
Level accuracy:	Per voltage and frequency input
Timing accuracy:	$\pm 100$ ms

\*Specifications subject to change without notice.

### OUTPUTS

#### ANALOG OUTPUTS

Type:	Active
Outputs:	8 channels; specify one of the following output ranges when ordering:
	Output range      Maximum load
	0 - 1 mA            12 k $\Omega$
	0 - 5 mA            2.4 k $\Omega$
	0 - 10 mA          1.2 k $\Omega$
	4 - 20 mA          600 $\Omega$
Isolation:	Fully isolated
Accuracy:	$\pm 1\%$ of full scale
Response time:	100% indication in less than 3 power system cycles (50 ms @ 60 Hz)

#### SOLID STATE TRIP

Make and carry:	15 A @ 250 VDC for 500 ms
Output relays:	
Configuration:	1 TRIP:                      Form A 2 CLOSE:                    Form A 3 - 7 AUXILIARY:          Form C 8 SELF-TEST WARNING:    Form C
Contact material:	Silver alloy

### COMMUNICATIONS

Serial Ports:	300 - 19,200 baud, programmable parity, ModBus® RTU or DNP 3.0 protocol
Ethernet Port:	10BaseT, RJ45 Connector, ModBus® RTU over TCP/IP

### POWER SUPPLY

CONTROL POWER	
Options:	LO/HI (specified when ordering)
LO range:	DC = 20 to 60 V AC = 20 to 48 V @ 48 - 62 Hz
HI range:	DC = 88 to 300 V AC = 70 to 265 V @ 48 - 62Hz
Power:	25 VA nominal, 35 VA maximum
Voltage loss hold-up time:	30 ms

### ENVIRONMENTAL

Operating temperature range:	-40° C to +60° C
Ambient storage temperature:	-40° C to +85° C
Ambient shipping temperature:	-40° C to +85° C
Humidity:	Operating up to 95% (non condensing) @ 55C
Pollution degree:	2
IP rating:	IP40 (front), IP20 (back)

### APPROVALS TESTS

cULus:	UL508, UL1058, C22.2.No 14
CE:	EN60255-5, EN50263

### PRODUCTION TESTS

Thermal cycling:	Operational test at ambient, reducing to -40° C and then increasing to 60° C
Dielectric strength:	On CT inputs, VT inputs, control power inputs, switch inputs, coil supervision outputs, and relay outputs (2 kVac for 1-minute) to safety ground.

### TYPE TESTS

Dielectric voltage withstand:	EN60255-5
Impulse voltage withstand:	EN60255-5
Insulation resistance:	EN60255-5
Damped Oscillatory:	IEC 61000-4-18 / IEC 60255-22-1
Electrostatic Discharge:	EN61000-4-2 / IEC 60255-22-2
RF immunity:	EN61000-4-3 / IEC 60255-22-3
Fast Transient Disturbance:	EN61000-4-4 / IEC 60255-22-4
Surge Immunity:	EN61000-4-5 / IEC 60255-22-5
Conducted RF Immunity:	EN61000-4-6 / IEC 60255-22-6
Radiated & Conducted Emissions:	CISPR11 / CISPR22 / IEC 60255-25
Sinusoidal Vibration:	IEC 60255-21-1
Shock & Bump:	IEC 60255-21-2
Siesmic:	IEC 60255-21-3
Power magnetic Immunity:	IEC 61000-4-8
Pulse Magnetic Immunity:	IEC 61000-4-9
Voltage Dip & interruption:	IEC 61000-4-11
Ingress Protection:	IEC 60529
Environmental (Cold):	IEC 60068-2-1
Environmental (Dry heat):	IEC 60068-2-2
Relative Humidity Cyclic:	IEC 60068-2-30
EFT:	IEEE / ANSI C37.90.1
Damped Oscillatory:	IEEE / ANSI C37.90.1
RF Immunity:	IEEE/ANSIC37.90.2
ESD:	IEEE/ANSIC37.90.3
Safety:	UL508 / UL C22.2-14 / UL1053

Please refer to Multilin 750/760 Feeder Protection System Instruction Manual for complete technical specifications

## Ordering

750/760	*	*	*	*	*	*	*	*	Description
Phase Current Inputs	P1 P5								1 A phase current inputs 5 A phase current inputs
Ground Current Inputs		G1 G5							1 A zero sequence current inputs 5 A zero sequence current inputs
Sensitive Ground Current Inputs			S1 S5						1 A sensitive ground current input 5 A sensitive ground current input
Power Supply Options				LO HI					20 – 60 VDC, 20 – 48 VAC @ 48 – 62 Hz 88 – 300 VDC, 70 – 265 VAC @ 48 – 62 Hz
Analog Outputs					A1 A5 A10 A20				Eight 0 – 1 mA analog outputs Eight 0 – 5 mA analog outputs Eight 0 – 10 mA analog outputs Eight 4 – 20 mA analog outputs
Breaker Status LED						R G			Red breaker closed LED Green breaker closed LED
Enhancements							E T		Enhanced display, larger LCD, improved keypad Enhanced display with Ethernet 10BaseT option
Environmental Protection								H	Harsh Chemical Environment Option

## GEGridSolutions.com

IEC is a registered trademark of Commission Electrotechnique Internationale. IEEE is a registered trademark of the Institute of Electrical Electronics Engineers, Inc. Modbus is a registered trademark of Schneider Automation. NERC is a registered trademark of North American Electric Reliability Council. NIST is a registered trademark of the National Institute of Standards and Technology.

GE, the GE monogram, Multilin, FlexLogic, EnerVista and CyberSentry are trademarks of General Electric Company.

GE reserves the right to make changes to specifications of products described at any time without notice and without obligation to notify any person of such changes.

Copyright 2015, General Electric Company. All Rights Reserved.



imagination at work

GEA-31955-(E)  
English  
160307