

# Multilin 339

## Motor Protection System

The Multilin™ 339 is a member of the Multilin 3 Series protective relay platform and has been designed for the protection, control and management of medium voltage motors in industrial applications. The Multilin 339 delivers unparalleled protection, control, diagnostics and communications in an industry leading drawout construction. Providing simplified setup configuration through the use of the Motor Settings Auto-Configurator, advanced graphical diagnostics with the Motor Health Report and support for multiple communication protocols including IEC® 61850, the 339 Motor Protection System provides comprehensive motor protection for most small and medium sized motors.

### Key Benefits

- Cost-effective and flexible protection and control device for motors
- Field-proven algorithms and reliable protection to avoid unwanted trips or under-protection
- Ease of use and standardization with simplified motor setup and universal CT inputs
- Enhanced Thermal Model including RTD and current unbalance biasing
- Environmental monitoring system to monitor operating conditions and plan preventative maintenance
- Time stamped event reports, waveform capture, motor start and motor trending
- Powerful security and hierarchical password control for centralized management
- Reduced wiring via remote RTD's using the RMIO module and support for 3 internal RTDs
- Advanced power system and switchgear diagnostics
- Customized motor overload curve Flex curves
- Detailed Motor Health Report with critical data
- Switchgear diagnostics and easy troubleshooting by CT/VT supervision, trip/close circuit supervision and LED/IO Test Mode
- Drawout design simplifies testing, commissioning and maintenance, thereby increasing process uptime
- Flexible communications with multiple ports and protocols allowing seamless integration
- Robust design exceeding industry standards, with Automotive Grade components and advanced testing procedures such as accelerated life cycle testing
- Simplified migration of legacy MII Family relays to the 3 Series platform
- Intuitive configuration software and user-friendly logic configuration tool

### Applications

- Protection and control of LV or MV motors of various sizes
- Protection of pumps, conveyors, fans, compressors, and others in process or manufacturing industries.
- Applications requiring fast and secure communications
- Harsh environments requiring protection against corrosive chemicals and humid environments



## Protection & Control

- Thermal model biased with RTD and negative sequence current feedback
- Comprehensive current-based protection including directional elements and Contactor Current Supervision
- Start supervision, inhibit, load increase and mechanical jam
- Underpower/undercurrent and directional power

## Metering & Monitoring

- Comprehensive metering
- Programmable oscillography up to 32 samples per cycle and digital states
- SNTP or IRIG-B clock synchronization
- Motor health and switchgear diagnostics including breaker monitoring, CT/VT and close/trip coil supervision
- Relay health diagnostics

## Communications

- Front USB and rear serial, Copper and Fiber Ethernet ports
- Multiple communication protocols including IEC 61850, IEC 61850 GOOSE, Modbus® TCP/IP, Modbus RTU, DNP 3.0, IEC 60870-5-104, IEC 60870-5-103

## EnerVista™ Software

- Simplified setup and configuration
- Strong document management system
- Full featured monitoring and data recording
- Maintenance and troubleshooting tool
- Seamless integration toolkit
- Setting conversion tool for MII Family to 3 Series



## Overview

The Multilin 339 relay is a member of the 3 Series family of Multilin relays. This motor protective device is used to perform protection, control, metering and supervision of asynchronous LV and MV motors in different process and manufacturing industries.

The basic protection functions of this relay include motor thermal model, time-delayed and instantaneous overcurrent, ground overcurrent and sensitive ground overcurrent protection. Additional control features such as logic control are available for applications that require additional motor control functionality.

The robust 339 streamlines user work flow processes and simplifies engineering tasks such as configuration, wiring, testing, commissioning, and maintenance. This cost-effective relay also offers enhanced features such as diagnostics, preventative maintenance, motor health reports and advanced security features.

## Easy to Use

### Drawout & Non-Drawout Construction

The 339 is offered in both a drawout or a non-drawout construction. In the drawout case design the 339 simplifies installation and improves site safety as the need to open switchgear doors or rewire the device after testing is eliminated. As communication cables remain connected to the chassis, even when the relay is withdrawn, communications connection is retained.

The 339 protection relay chassis used with a drawout relay is available separately, for use as a partial replacement or in test environments. The drawout relay with no chassis is also available to order as a spare unit.

### Application Flexibility & Ease of Wiring

Removable terminals ease wiring and in-system testing or troubleshooting.

Available universal CT inputs along with a software-configurable input range (1A and/or 5A) helps to standardize the design and reduce

the number of order codes. There is also no need to change the entire relay in case of a design change or future switchgear modifications. Mixed inputs of 1A or 5A are advantageous for applications where the ground CT is different from the phase CTs.

### Fast & Simple Configuration

With quick setup screens the 339 requires minimal configuration for standard feeder applications. Utilizing the powerful EnerVista 3 Series setup software, device configuration can be completed in one easy step.

## Advanced Communications

### Easy Integration Into New or Existing Infrastructure

With several Ethernet and serial port options, and a variety of protocols, the 339 provides advanced and flexible communication selections for new and existing energy management, SCADA and DCS systems.

## 339 Relay Features

### Easy to Configure- 1 Simple Step



### Advanced & Flexible Communication Options



Non-drawout case design

### Easy to Use - Drawout Case

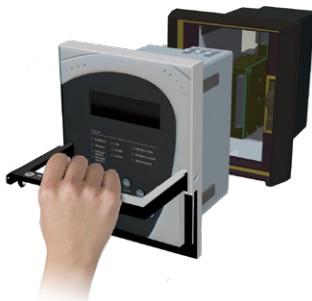

### Diagnostic Alarms

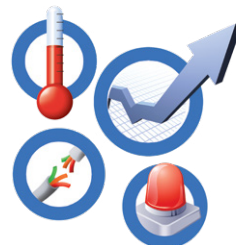

Drawout case design

## Enhanced Diagnostics

### Preventative Maintenance

The 339 allows users to track relay exposure to extreme environmental conditions by monitoring and alarming at high ambient temperatures. This data allows proactive scheduling of regular maintenance work and upgrade activities. The diagnostics data enables the user to understand degradation of electronics due to extreme conditions.

### Switchgear Diagnostics

The current and voltage transformer monitoring feature allows users to easily locate and troubleshoot potential failures or mis-operations caused by CTs or VTs. Trip/Close Circuit Monitoring provides constant monitoring of the health the control circuit.

### Failure Alarm

The 339 detects and alarms on communication port and IRIG-B failures. The 339 also enables users

to analyze system performance via diagnostics information such as event records, oscillography, etc. It issues detailed motor health reports and alarms when thresholds are exceeded.

## Protection & Control

The 339 motor protection system is designed to protect and manage various sizes of LV and MV asynchronous motors and driven equipment. Flexible and powerful, the 339 provides advanced motor protection, control and monitoring in one integrated, economical drawout or non-drawout design. The 339 contains a full range of self contained protection and control elements as detailed in the Functional Block Diagram and Features table.

### Motor Thermal Model (49, 38, 46, 50L, 66)

To provide optimal protection and maximum runtime, the 339 Motor Protection System employs GE's Industry leading advanced Thermal Model, consisting of six key elements:

- Overload Curves
- Unbalance Biasing
- Hot/Cold Safe Stall Ratio
- Motor Cooling Time Constants
- Thermal Inhibit and Emergency Restart
- RTD Biasing

### FlexCurves

A smooth custom overload curve is created using FlexCurves™. These curves can be used to protect motors with different rotor damage and stator damage curves, allowing total motor design capacity with complete protection.

### Voltage and Frequency Protection (27P/\_1, 59P/\_2, 81O/U)

Overvoltage and Undervoltage elements provide protection for voltage sensitive equipment such as motors as well as control for permissive functions and source transfer schemes.

Overfrequency and underfrequency elements improve network (grid) stability using voltage or frequency based load shedding techniques.

## Functional Block Diagram

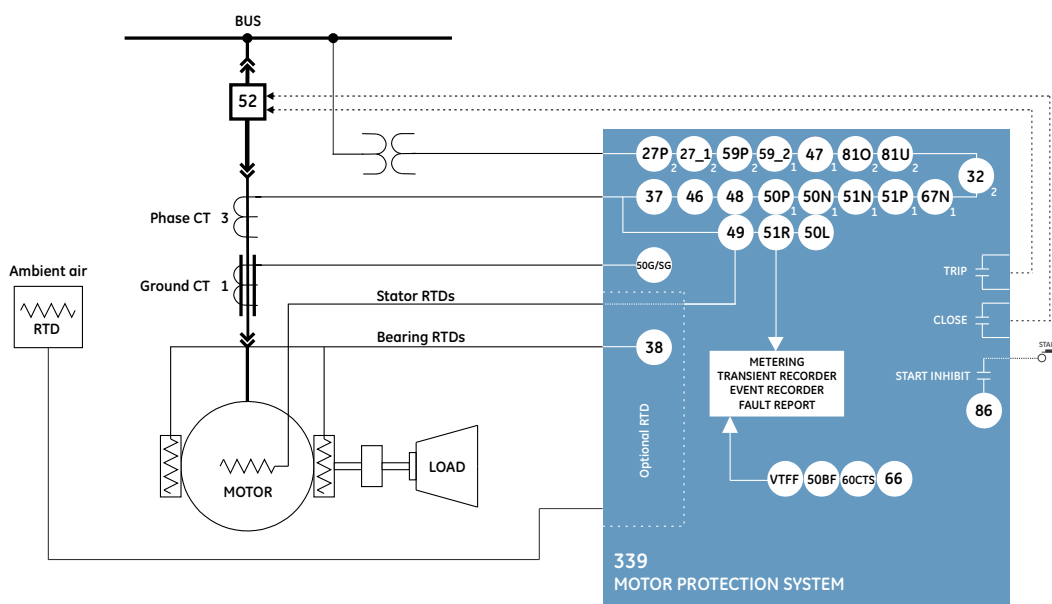

### ANSI® Device Numbers & Functions

DEVICE NUMBER	61850 LOGICAL NODE	DESCRIPTION
27_1	psseqPTUV	Positive Sequence Undervoltage
27P	phsPTUV	Phase Undervoltage
32	PDOP	Directional Power
37	PTUC	Undercurrent
37P	PDUP	Underpower
38/49T	rtdGGIO6	Bearing RTD
		Stator/Ambient/Other RTD Trouble Alarm
46	unbalPTOC	Current Unbalance
47	phsrevPTOV	Voltage Phase Reversal
48	accelPTOC	Acceleration Time
49	PTTR	Thermal Protection/Stall Protection
50BF	RBRF	Breaker Failure / Welded Contactor

DEVICE NUMBER	61850 LOGICAL NODE	DESCRIPTION
50G/SG	gndPIOC	Ground Fault/Sensitive Ground Fault (CBCT)
50L	ldincPTOC	Load Increase Alarm
50N	ndPIOC	Neutral Instantaneous Overcurrent
50P	scPIOC	Short Circuit
51N	ndPTOC	Neutral Timed Overcurrent
51P	phsPTOC	Phase Timed Overcurrent
51R	jamPTOC	Mechanical Jam
59_2	ngseqPTOV	Negative Sequence Overvoltage
59P	phsPTOV	Phase Overvoltage
60CTS	-	CT Supervision

DEVICE NUMBER	61850 LOGICAL NODE	DESCRIPTION
66	PMRI	Starts per Hour & Time Between Starts
		Restart Block
		Thermal Inhibit
67N	ndRDIR	Neutral Directional Element
81O	PTOF	Overfrequency
81U	PTUF	Underfrequency
86	-	Lockout
VTF (60VTS)	-	VT Fuse Failure

**Unbalance (Negative Sequence) Biasing (46)**

Negative sequence current, which causes additional rotor heating, is not accounted for in the thermal limit curves provided by the manufacturer. The 339 measures current unbalance as a ratio of negative to positive sequence current. The thermal model is then biased to reflect the additional rotor heating.

**RTD Biasing (38)**

The Thermal Model relies solely on measured current to determine motor heating, assuming an ambient temperature of 40°C and normal motor cooling. The actual motor temperature will increase due to abnormally high ambient temperatures or if the motor cooling systems have failed.

RTD Biasing enhances the motor thermal model by calculating the thermal capacity used based on available Stator RTD temperatures.

RTD Biasing does not replace the Thermal Capacity Used (TCU) calculated using the motor current. It provides a second and independent measure of thermal capacity used. Based on a programmable curve, the 339 will calculate the TCU at any given temperature. This TCU is then compared to that of the thermal model, and the larger of the two will be used.

**Hot / Cold Safe Stall Ratio**

The ratio defines the steady state level of thermal capacity used (TCU) by the motor. This level corresponds to normal operating temperature of a fully loaded motor and will be adjusted proportionally if the motor load is lower than rated.

**Motor Cool Time Constants**

The 339 has a true exponential cooldown characteristic which mimics actual motor cooling rates, providing that motor cooling time constants are available for both the stopped and running states. When ordered with RTD's the stopped and running cool time constants will be calculated by the 339 based on the cooling rate of the hottest RTD, the hot/cold stall ratio, the ambient temperature, the measured motor load and the programmed service factor or overload pickup.

**Start Inhibit**

The Start Inhibit function prevents starting of a motor when insufficient thermal capacity is available or a motor start supervision function dictates inhibit.

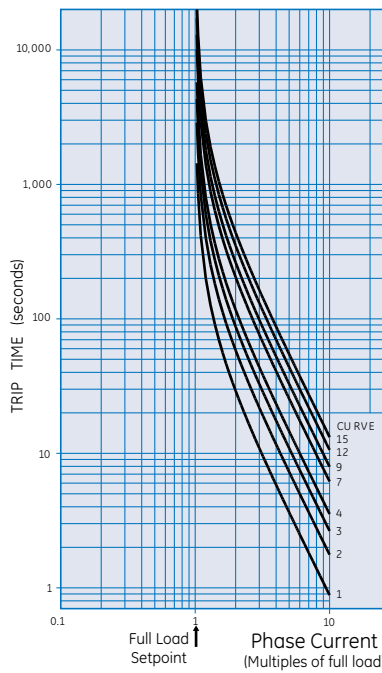

15 Standard Curves available in the 339.

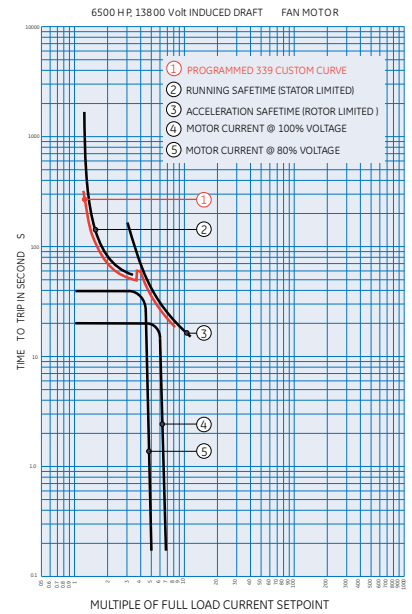

Typical Flexcurve

**Motor Start Supervision (66)**

Motor Start Supervision consists of the following features: Time-Between-Starts, Starts-per-hour, Restart Time.

These elements guard the motor against excessive starting duty, which is normally defined by the motor manufacturer in addition to the thermal damage curves.

**Undercurrent/Underpower (37)**

The undercurrent function is used to detect a decrease in motor current caused by a decrease in motor load. This is especially useful for indication of conditions such as: loss of suction for pumps, loss of airflow for fans, or a broken belt for conveyors. A separate undercurrent alarm may be set to provide early warning.

**Directional Power (32)**

The Directional Power element responds to three-phase directional power and is designed for reverse power (32REV) and low forward power (32FWD). One of the applications is to prevent motors running like generators when the motor supplies active power.

**Mechanical Jam (51R)**

During overload conditions, quick motor shutdown can reduce damage to gears, bearings and other mechanical parts associated with the drive combination.

**Ground Overcurrent (50N, 50G/SG, 51N)**

For zero sequence ground overcurrent protection, all three of the motor conductors must pass through a separate ground CT. CTs may be selected to detect either high-impedance zero sequence ground or residual ground currents. The ground fault trip can be instantaneous or programmed for a time delay.

**Directional Overcurrent (67N, 67G)**

The Neutral Directional element is used to discriminate between faults that occur in the forward direction, and faults that occur in the reverse direction.

**RTD Protection (38)**

The 339 provides programmable RTD inputs via the remote RMIO that are used for monitoring

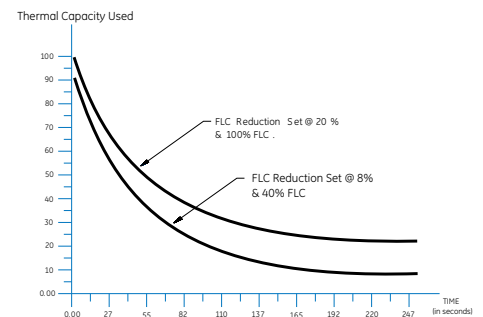

Motor cooling curves

the Stator, Bearing and Ambient temperatures. Each RTD input has 2 operational levels: alarm and trip. The 339 supports RTD trip voting and provides open and short RTD monitoring.

CIO has been designed to be mounted close to the motor to reduce the length of the RTD cables and the associated costs. It can be mounted UP TO 250m away from the relay.

### Contact Current Supervision

The fault current can exceed the withstand current which contactor is rated to interrupt. The 339 blocks the operation of the output trip relay and operates a selected auxiliary output relay to transfer the trip to the upstream breaker which is rated to interrupt the fault currents.

### VFD-Driven Motor Protection

The Multilin 339 provides protection and control for motors fed through VFDs (Variable Frequency Drives). An advanced algorithm allows switchable current and voltage tracking in case VFD is bypassed.

### Two-speed motor

Two-speed motors have two windings wound into one stator. These motors rely on contactors to accomplish speed changes by altering the winding configurations. The 339 motor relay provides a complete set of protective functions for each speed.

## Automation and Integration

### Logic Elements

The 339 relay has sixteen Logic Elements available for the user to build simple logic using the state of any programmed contact, virtual, or remote input, or the output operand of a protection or control element.

Use the logic element feature to assign up to eight triggering inputs in an "AND/OR/NOR/NAND/XOR/XNOR" gate for the logic element operation, and up to four blocking inputs in an "AND/OR/NOR/NAND/XOR/XNOR" gate for defining the block signal. Trigger and block sources are grouped for ease of use. Pickup and dropout timers are available for delaying the operation and reset.

### Inputs/Outputs

The 339 features the following inputs and outputs for monitoring and control of typical motor applications:

- 10 contact Inputs with programmable thresholds
- 7 Outputs (2 Form A, 5 Form C) as standard and 4 Outputs (1 Form A, 3 Form C) when internal RTD option is selected
- 5 Form C output relays

### Virtual Inputs

Virtual inputs allow communication devices the ability to write digital commands to the 339 relay. These commands could be starting or stopping the motor or blocking protection elements.

### Breaker Failure/Welded Contactor (50BF)

The Breaker Failure function is used to determine when a trip command sent to a breaker has not been executed within a selectable time delay. In the event of a breaker failure, the 339 will issue an additional signal to trip the breakers connected to the same busbar or to signal the trip of upstream breakers.

### IEC 61850

The 339 supports IEC 61850 Logical Nodes which allows for digital communications to DCS, SCADA and higher level control systems.

In addition, the 339 also supports IEC 61850 GOOSE communication, providing a means of sharing digital point state information between 339's or other IEC 61850 compliant IED's.

- Eliminates the need for hardwiring contact inputs to contact outputs via communication messaging.
- Transmits information from one relay to the next in as fast as 8 ms.
- Enables sequence coordination with upstream and downstream devices.
- When Breaker Open operation malfunctions, GOOSE messaging sends a signal to the upstream breaker to trip and clear the fault.

## Metering, Monitoring and Diagnostics

### Event Recording

Events consist of a broad range of change of state occurrences, including pickups, trips, contact operations, alarms and self test status. The 339 relay stores up to 256 events, time tagged to the nearest millisecond. This provides the information required to determine sequence of events, facilitating the diagnosis of relay operation. Event types are individually maskable in order to avoid generating undesired events, and include the metered values at the moment of the event.

### Oscillography/ Transient Fault Recorder

The 339 captures current and voltage waveforms and digital channels at up to 32 samples per cycle (user-selectable). Multiple records can be stored in the relay at any given time with a maximum length of 192 cycles. Oscillography is triggered either by internal signals or an external contact.

## Logic Designer

The screenshot shows the Logic Designer interface. On the left is a table with settings for Logic Element 1. On the right is a logic diagram showing an OR gate with eight inputs and an XOR gate with four inputs, both leading to an AND gate with a 5 ms delay and a 15 ms ramp.

SETTING	PARAMETER
<b>LOGIC ELEMENT 1</b>	
Name	Alarm #1
Function	Disabled
Asserted	On
Number of Triggers	8
Trigger Source 1	Contact IN 1 On
Trigger Source 2	Contact IN 2 On
Trigger Source 3	LE 1 Trip PKP
Trigger Source 4	LE 2 Trip OP
Trigger Source 5	Virtual IN 1 On
Trigger Source 6	Virtual IN 2 On
Trigger Source 7	Remote IN 10 Off
Trigger Source 8	Remote IN 21 Off
Trigger Logic	OR
Pickup Time Delay	5 ms
Dropout Time Delay	15 ms
Relays	Relay : 4
Number of Blocks	4
Block 1	Virtual IN 1 On
Block 2	Virtual IN 2 On
Block 3	Remote IN 1 On
Block 4	Remote IN 7 Off
Block Logic	XOR

Sixteen logic elements available for applications such as manual control, interlocking and peer to peer tripping.

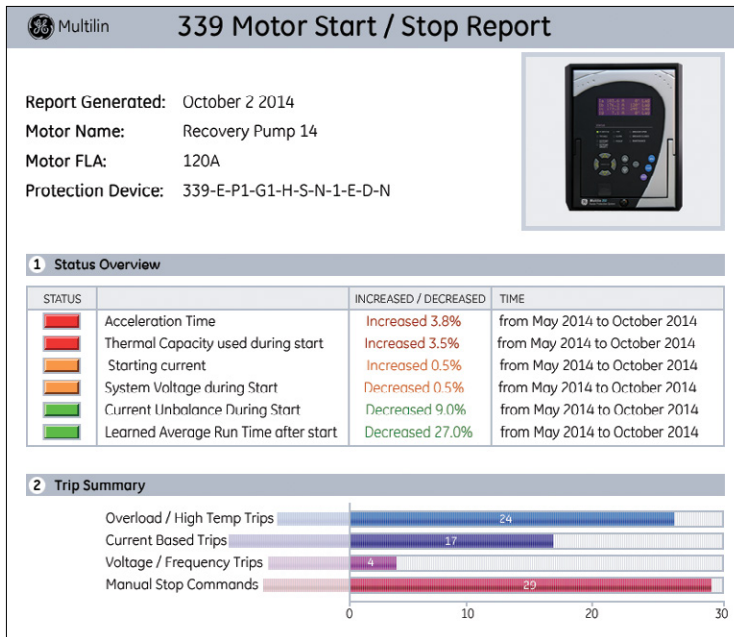

The Motor Health Report allows you to easily "see" how your motor is doing:

- Start/stop history
- Comprehensive trip details
- Learned acceleration time and starting current
- Many other motor health details

**Test Mode**

The Test Mode for 3 Series relays consists of testing front panel LEDs, Inputs and Outputs. It can be used to test the SCADA system as well.

**Statistical Data**

The 339 records the following statistical data in order to assist in diagnosing common motor faults, as well as assisting in planning preventative maintenance.

- Total running hours
- Number of motor starts
- Total number of motor trips
- Current: Ia, Ib, Ic, In, Ig, Isg
- Phase-to-phase and phase-to-ground voltages: Van, Vbn, Vcn, Vab, Vbc, Vca
- Active power (3-phase) kW
- Reactive power (3-phase) kVAR
- Frequency
- Current Unbalance
- Motor load current as a % of full load
- Motor thermal capacity used
- Stator/Bearing/Ambient RTD temperature
- Demand (different types)

**Trip/Close Coil Monitoring**

The 339 can be used to monitor the integrity of both the breaker trip and closing coils and circuits. The supervision inputs monitor both the auxiliary voltage levels, while the outputs monitor the continuity of the trip and/or closing circuits, by applying a small current through the circuits.

**Pre-Trip Alarms**

The 339 can trigger an alarm prior to a trip caused by the following conditions:

- Thermal Overload
- Ground Fault
- Unbalance
- Undercurrent
- RTD over temperature
- Broken RTD sensor
- Internal self-test

**Metering Actual Values**

The 339 provides users with the following metering information in order to accurately monitor the operating conditions of the motor:

- Current: Ia, Ib, Ic, In, Ig, Isg
- Phase-to-phase and phase-to-ground voltages: Van, Vbn, Vcn, Vab, Vbc, Vca
- Active power (3-phase) kW
- Reactive power (3-phase) kVAR
- Frequency
- Current Unbalance
- Motor load current as a % of full load
- Motor thermal capacity used
- Stator/Bearing/Ambient RTD temperature
- Demand (different types)

**Advanced Device Health Diagnostics**

The 339 performs comprehensive device health diagnostic tests during startup and continuously at runtime to test major functions and critical hardware. These diagnostic tests monitor for conditions that could impact system reliability. Device status is communicated via SCADA

**Power System Troubleshooting**

Analyze power system disturbances with transient fault recorder and event records

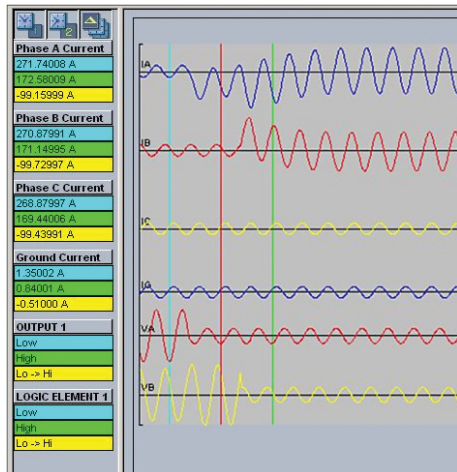

Event Records // Quick Connect: Quick Connect Device: Actual Values: A3 Records

Event	Select	Date	Time	Cause of Event
76	<input type="checkbox"/>	03/4/2009	15:02:55.581	Reset
75	<input checked="" type="checkbox"/>	03/4/2009	15:02:12.908	Breaker Status Open
74	<input type="checkbox"/>	03/4/2009	15:02:12.901	Contact Input 1 Off
73	<input type="checkbox"/>	03/4/2009	15:02:11.775	Phase C TOC Trip Operate
72	<input type="checkbox"/>	03/4/2009	15:02:11.775	Phase A TOC Trip Operate
71	<input type="checkbox"/>	03/4/2009	15:02:11.759	Output Relay 3
70	<input type="checkbox"/>	03/4/2009	15:02:11.759	Trip Coil
69	<input type="checkbox"/>	03/4/2009	15:02:11.759	Trip Coil Pickup
68	<input type="checkbox"/>	03/4/2009	15:02:11.758	Phase TOC Trip Operate
67	<input type="checkbox"/>	03/4/2009	15:02:11.758	Phase B TOC Trip Operate

All None Select Events 75

Event Parameter	Value
Event Ia	0° Lag
Event Ib	120° Lag
Event Ic	240° Lag
Event Ig	0° Lag
Event Frequency	59.99 Hz
Therm Cap PH A	0.0%
Therm Cap PH B	0.0%
Therm Cap PH C	0.0%

PARAMETER	VALUE
Fault Report Order Code	350-LPSGSHMVCV5EDN
Fault Report Feeder Name	Feeder Name
Fault Report Firmware Version	2.20
Fault Report Date	06/30/2016
Fault Report Time	07:35:17
Fault Report Fault Type	Phase IOC1 Trip OP
Active Setpoint Group	Group 1
Fault Report Ia	40.0 A
Fault Report Ia Angle	358 °
Fault Report Ib	40.0 A
Fault Report Ib Angle	117 °
Fault Report Ic	39.3 A
Fault Report Ic Angle	237 °
Fault Report Ig	0.0 A
Fault Report Ig Angle	0 °
Fault Report In	0.0 A
Fault Report In Angle	0 °
Fault Report Va	30 V
Fault Report Va Angle	0 °
Fault Report Vb	30 V
Fault Report Vb Angle	120 °
Fault Report Vc	30 V
Fault Report Vc Angle	240 °
Fault Report Vab	52 V
Fault Report Vab Angle	330 °

Generated at: September 15 2010 16:56:05

### SECURITY/CHANGE HISTORY REPORT

Device Summary	
Device Name:	339
Device Type:	SR 339
Order Code:	339-CP5G5HESNP2EDH
Firmware Version:	1.30
Serial Number:	BL0A09000564
Communication:	COM 3, 115200



Setting Changes History									
Session#	Date of Change	Method of Change	# Of Changes	Password Entered	Changes by Whom IP /Mac	Event Type	Filename	Status	Firm. Version
1	09/15/2010 07:09:05 PM	USB	25	Yes	0:0:0:0	Setpoint Change		Relay Not Ready	130
2	09/15/2010 07:13:32 PM	USB	2	Yes	3:13:61:141	Setpoint Change		Relay Ready	130

Setting Changes Detail History					
Session#	Date Of Change	Old Value	New Value	Data Item	Modbus Address
1	09/15/2010 07:09:05 PM	0	1	Relay Status	0X39e
1	09/15/2010 07:09:13 PM	120	240	Bus VT Secondary	0X118
1	09/15/2010 07:09:20 PM	0	1	Supply Frequency	0X11b
1	09/15/2010 07:09:35 PM	100	1500	CT Primary	0X10a
1	09/15/2010 07:09:48 PM	0	448	Low Speed Switch	0X57e
1	09/15/2010 07:09:53 PM	0	1	Enable Two Speed Motor	0X136
1	09/15/2010 07:10:07 PM	0	1	Thermal Overload Function	0X2b9
1	09/15/2010 07:10:07 PM	0	1	Thermal Alarm Function	0X2bc
1	09/15/2010 07:10:18 PM	0	1	Short Circuit Function	0X3b3
1	09/15/2010 07:10:36 PM	0	1	Mechanical Jam Function	0X2cd



Trace any setting changes with security audit trail

communications and the front panel display. This continuous monitoring and early detection of possible issues helps improve system availability by employing predictive maintenance.

### Time Synchronization

IRIG-B is a standard time code format that allows time stamping of events to be synchronized among connected devices to within 1 millisecond. An IRIG-B input is provided in the 339 to allow time synchronization using a GPS clock over a wide area. The 339 IRIG-B supports both AM and DC time synchronization, with an auto detect feature that eliminates the need for configuration.

### Temperature Monitoring

The 339 continually monitors ambient temperature around the relay and alarms when the device is exposed to extreme temperatures and undesirable conditions such as airconditioning unit or station heater failures.

The EnerVista Viewpoint maintenance tool allows users to review and analyze the time period a 339 relay is exposed to certain temperature ranges.

### Motor Health Report

The Multilin 339 relay provides motor diagnostic information in a legible easy to use format that enables the user to make informed decisions on the health of their motor.

Based on the graphical representation and trended values of the motor data gathered by the 339, this enables users to quickly identify process and motor issues prior to a process failure.

The 339 Motor Health Report provides a summary page detailing information on related motor performance.

The following information is detailed in the 339 Motor Health Report:

- Motor Acceleration Time
- Starting Current
- Thermal capacity used during starting
- Average Motor Load
- Average Phase currents
- Current unbalance
- Ground current

## Security

### Password Control

The password system has been designed to facilitate a hierarchy for centralized management. With the implementation of the Password Security feature in the 339 relay, extra measures have been taken to ensure unauthorized changes are not made to the relay. When password security is enabled, changing of setpoints or issuing of commands requires passwords to be entered. Separate passwords are supported for remote and local operators, and separate access levels support changing of setpoints or sending commands.

## Advanced Communications

The 339 utilizes the most advanced communication technologies today making it the easiest and most flexible motor protection relay to use and integrate into new and existing infrastructures. Multiple communication ports and protocols allow control and easy access to information from the 339. All communication ports are capable of communicating simultaneously.

The 339 supports the most popular industry standard protocols enabling easy, direct integration into electrical SCADA and HMI systems. Modbus RTU is provided as standard with a RS485 networking port. The following optional protocols are available:

- IEC 61850
- Modbus TCP/IP
- IEC 61850 GOOSE
- IEC 60870-5-104
- DNP 3.0
- IEC 60870-5-103
- Modbus RTU

## EnerVista Software

The EnerVista™ suite is an industry leading set of software programs that simplifies every aspect of using the 339 relay. The EnerVista suite provides all the tools to monitor the status of the protected asset, maintain the relay, and integrate the information measured into DCS or SCADA monitoring systems. Convenient COMTRADE and sequence of event viewers are an integral part of the 339 set up software and are included to ensure proper protection and system operation.

### Simplified Motor Setting

Included with every 339 Motor Protection System is the Multilin Simplified Motor Setup. The Simplified Motor Setup provides users with a quick and easy method to setup and start the motor and process in applications that require fast commissioning.

The Simplified Motor Setup will generate a complete 339 setting file based on the motor nameplate and system information entered by the user. Once all the information is entered, the Simplified Motor Setup will generate the settings file, as well as provide the documentation indicating which settings were enabled, along with an explanation of the specific parameters entered. The Simplified Motor Setup will provide a detailed setting file in PDF format that can be saved or printed for future reference.

## Launchpad

EnerVista Launchpad is a powerful software package that provides users with all of the set up and support tools needed for configuring and maintaining GE products. The setup software within Launchpad allows configuring devices in real time by communicating using serial, Ethernet or modem connections, or offline by creating setting files to be sent to devices at a later time.

Included in Launchpad is a document archiving and management system that ensures critical documentation is up-to-date and available when needed. Documents made available include:

- Manuals
- Brochures
- Application Notes
- Wiring Diagrams
- Guideform Specifications
- FAQs
- SService Bulletins

## Viewpoint Monitoring

Viewpoint Monitoring is a simple to use and full featured monitoring and data recording software package for small systems. Viewpoint monitoring provides a complete HMI package with the following functionality:

- Plug and play device monitoring
- System single line monitoring and control
- Annunciator alarm screens

- Trending reports
- Automatic event retrieval
- Automatic waveform retrieval

## Viewpoint Maintenance

Viewpoint Maintenance provides tools that will increase the security of the 339 Motor Protection System. Viewpoint Maintenance will create reports on the operating status of the relay, and simplify the steps to troubleshoot protected motors.

The tools available in Viewpoint Maintenance include:

- Settings Security Audit Trail
- Device Health Report
- Comprehensive Fault Diagnostics

## EnerVista Integrator

EnerVista Integrator is a toolkit that allows seamless integration of Multilin devices into new or existing automation systems.

Included in the EnerVista Integrator is:

- OPC/DDE Server
- Multilin Devices
- Automatic Event Retrieval
- Automatic Waveform Retrieval

## User Interface



### TWELVE LEDS (8 optional programmable LEDs)

**IN SERVICE:** This indicator will be on continuously lit if the relay is functioning normally and no major self-test errors have been detected.

**TROUBLE:** Trouble indicator LED will be AMBER if there is a problem with the relay or if relay is not programmed.

**LOCKOUT:** Lockout initiates when a lockout trip is active.

**RUNNING:** Indicates that the motor is running in normal operation

**STOPPED:** Indicates that the motor is stopped

**STARTING:** Indicates that the motor is in the starting process

**TRIP:** Indicates that the relay has tripped the motor offline based on predefined programmed conditions.

**ALARM:** Indicates that the motor is currently operating in an alarm condition and may proceed to a trip condition if not addressed.

**MAINTENANCE:** Environmental alarms such as ambient temperature alarm, coil monitor or trip counter.

The display messages are organized into Main Menus, Pages, and Sub-pages.

There are four main menus labeled Actual Values, Quick Setup, Setpoints, and Maintenance. Pressing the MENU key followed by the MESSAGE key scrolls through the four Main Menu Headers. The ten button keypad allows users easy access to relay configuration information and control commands.

### INSTALLATION OPTIONS:

Draw out and non draw out options available



### Dimensions

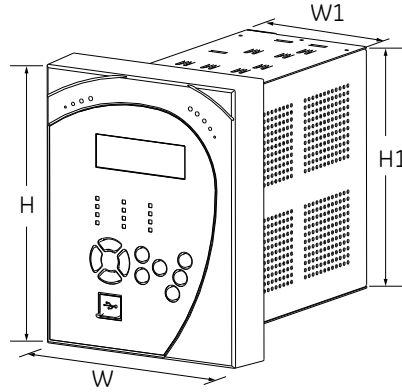
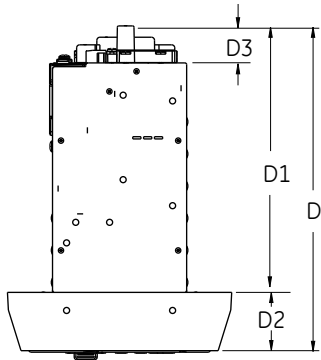

	DRAWOUT		NON-DRAWOUT	
	in	mm	in	mm
H	7.93	201.5	7.98	202.7
W	6.62	168.2	6.23	158.2
D	9.62	244.2	9.35	237.5
W1	3.96	100.6	3.96	100.6
D1	7.89	200.4	7.88	200.2
D2	1.73	43.8	1.47	37.3
D3	1.087	27.6	0.755	19.17
H1	6.82	173.2	6.82	173.2

### Mounting

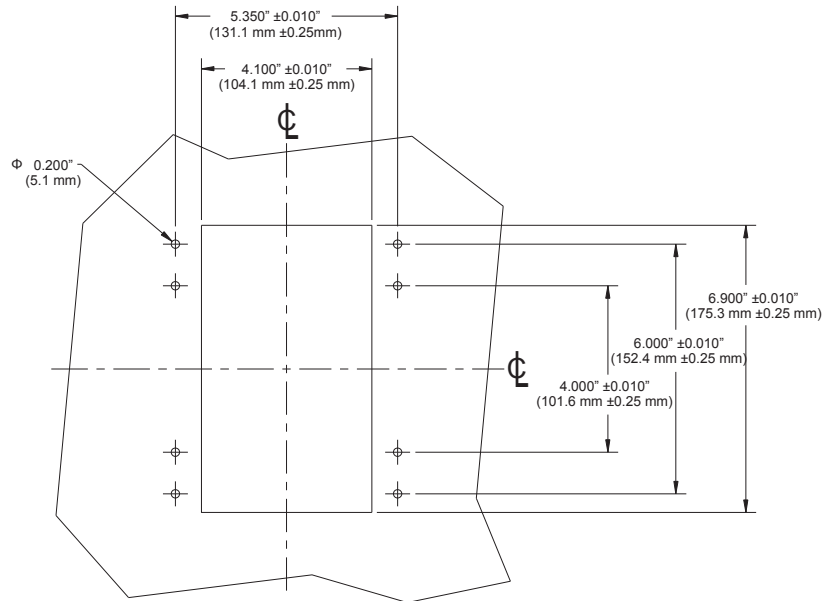

### 3 Series Depth Reducing Collar

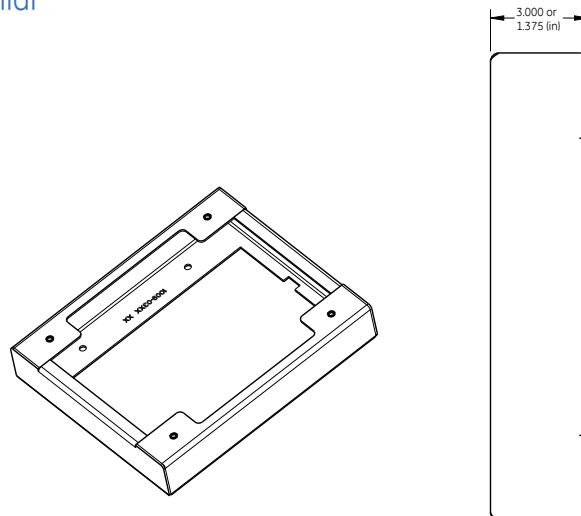

Feeder protection Function settings in one easy step

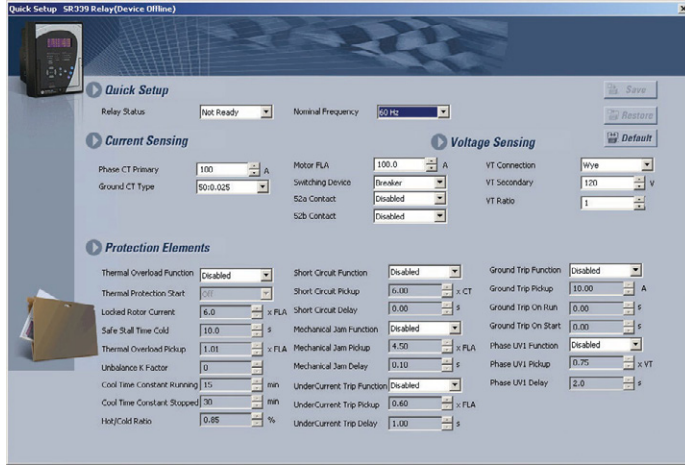

Fast and accurate configuration in one simple screen.

GROUPED F1 FEMHITS	OUTPUT RELAYS				OUTPUT RELAYS				OUTPUT RELAYS					
	R3	R4	R5	R6	GROUP 1	R3	R4	R5	R6	GROUP 2	R3	R4	R5	R6
Phase TOC	<input checked="" type="checkbox"/>	<input checked="" type="checkbox"/>	<input checked="" type="checkbox"/>	<input checked="" type="checkbox"/>	Locked Alarm	<input type="checkbox"/>	<input type="checkbox"/>	<input type="checkbox"/>	<input type="checkbox"/>	Trip	<input checked="" type="checkbox"/>	<input checked="" type="checkbox"/>	<input checked="" type="checkbox"/>	<input checked="" type="checkbox"/>
Phase IOC1	<input checked="" type="checkbox"/>	<input checked="" type="checkbox"/>	<input checked="" type="checkbox"/>	<input checked="" type="checkbox"/>	Disabled	<input type="checkbox"/>	<input type="checkbox"/>	<input type="checkbox"/>	<input type="checkbox"/>	Latched Alarm	<input type="checkbox"/>	<input type="checkbox"/>	<input type="checkbox"/>	<input type="checkbox"/>
Phase IOC2	<input type="checkbox"/>	<input type="checkbox"/>	<input type="checkbox"/>	<input type="checkbox"/>	Disabled	<input type="checkbox"/>	<input type="checkbox"/>	<input type="checkbox"/>	<input type="checkbox"/>	Disabled	<input type="checkbox"/>	<input type="checkbox"/>	<input type="checkbox"/>	<input type="checkbox"/>
Ground TOC	<input type="checkbox"/>	<input type="checkbox"/>	<input type="checkbox"/>	<input type="checkbox"/>	Disabled	<input type="checkbox"/>	<input type="checkbox"/>	<input type="checkbox"/>	<input type="checkbox"/>	Alarm	<input type="checkbox"/>	<input type="checkbox"/>	<input type="checkbox"/>	<input type="checkbox"/>
Ground IOC1	<input type="checkbox"/>	<input type="checkbox"/>	<input type="checkbox"/>	<input type="checkbox"/>	Disabled	<input type="checkbox"/>	<input type="checkbox"/>	<input type="checkbox"/>	<input type="checkbox"/>	Alarm	<input type="checkbox"/>	<input type="checkbox"/>	<input type="checkbox"/>	<input type="checkbox"/>
Ground IOC2	<input type="checkbox"/>	<input type="checkbox"/>	<input type="checkbox"/>	<input type="checkbox"/>	Disabled	<input type="checkbox"/>	<input type="checkbox"/>	<input type="checkbox"/>	<input type="checkbox"/>	Disabled	<input type="checkbox"/>	<input type="checkbox"/>	<input type="checkbox"/>	<input type="checkbox"/>
Ground Directional	<input type="checkbox"/>	<input type="checkbox"/>	<input type="checkbox"/>	<input type="checkbox"/>	Disabled	<input type="checkbox"/>	<input type="checkbox"/>	<input type="checkbox"/>	<input type="checkbox"/>	Disabled	<input type="checkbox"/>	<input type="checkbox"/>	<input type="checkbox"/>	<input type="checkbox"/>
Neutral TOC	<input type="checkbox"/>	<input type="checkbox"/>	<input type="checkbox"/>	<input type="checkbox"/>	Disabled	<input type="checkbox"/>	<input type="checkbox"/>	<input type="checkbox"/>	<input type="checkbox"/>	Alarm	<input type="checkbox"/>	<input type="checkbox"/>	<input type="checkbox"/>	<input type="checkbox"/>
Neutral IOC1	<input checked="" type="checkbox"/>	<input type="checkbox"/>	<input type="checkbox"/>	<input checked="" type="checkbox"/>	Latched Alarm	<input type="checkbox"/>	<input type="checkbox"/>	<input type="checkbox"/>	<input type="checkbox"/>	Disabled	<input type="checkbox"/>	<input type="checkbox"/>	<input type="checkbox"/>	<input type="checkbox"/>
Neutral IOC2	<input type="checkbox"/>	<input type="checkbox"/>	<input type="checkbox"/>	<input type="checkbox"/>	Disabled	<input type="checkbox"/>	<input type="checkbox"/>	<input type="checkbox"/>	<input type="checkbox"/>	Disabled	<input type="checkbox"/>	<input type="checkbox"/>	<input type="checkbox"/>	<input type="checkbox"/>
Neutral Directional	<input type="checkbox"/>	<input type="checkbox"/>	<input type="checkbox"/>	<input type="checkbox"/>	Disabled	<input type="checkbox"/>	<input type="checkbox"/>	<input type="checkbox"/>	<input type="checkbox"/>	Disabled	<input type="checkbox"/>	<input type="checkbox"/>	<input type="checkbox"/>	<input type="checkbox"/>
Negative Sequence IOC	<input type="checkbox"/>	<input type="checkbox"/>	<input type="checkbox"/>	<input type="checkbox"/>	Disabled	<input type="checkbox"/>	<input type="checkbox"/>	<input type="checkbox"/>	<input type="checkbox"/>	Disabled	<input type="checkbox"/>	<input type="checkbox"/>	<input type="checkbox"/>	<input type="checkbox"/>
Phase UV	<input checked="" type="checkbox"/>	<input type="checkbox"/>	<input type="checkbox"/>	<input checked="" type="checkbox"/>	Disabled	<input type="checkbox"/>	<input type="checkbox"/>	<input type="checkbox"/>	<input type="checkbox"/>	Disabled	<input type="checkbox"/>	<input type="checkbox"/>	<input type="checkbox"/>	<input type="checkbox"/>
Phase OV	<input type="checkbox"/>	<input type="checkbox"/>	<input type="checkbox"/>	<input type="checkbox"/>	Disabled	<input type="checkbox"/>	<input type="checkbox"/>	<input type="checkbox"/>	<input type="checkbox"/>	Disabled	<input type="checkbox"/>	<input type="checkbox"/>	<input type="checkbox"/>	<input type="checkbox"/>
Neutral UV	<input type="checkbox"/>	<input type="checkbox"/>	<input type="checkbox"/>	<input type="checkbox"/>	Disabled	<input type="checkbox"/>	<input type="checkbox"/>	<input type="checkbox"/>	<input type="checkbox"/>	Disabled	<input type="checkbox"/>	<input type="checkbox"/>	<input type="checkbox"/>	<input type="checkbox"/>
Negative Sequence OV	<input type="checkbox"/>	<input type="checkbox"/>	<input type="checkbox"/>	<input type="checkbox"/>	Disabled	<input type="checkbox"/>	<input type="checkbox"/>	<input type="checkbox"/>	<input type="checkbox"/>	Disabled	<input type="checkbox"/>	<input type="checkbox"/>	<input type="checkbox"/>	<input type="checkbox"/>
Auxiliary UV	<input type="checkbox"/>	<input type="checkbox"/>	<input type="checkbox"/>	<input type="checkbox"/>	Disabled	<input type="checkbox"/>	<input type="checkbox"/>	<input type="checkbox"/>	<input type="checkbox"/>	Disabled	<input type="checkbox"/>	<input type="checkbox"/>	<input type="checkbox"/>	<input type="checkbox"/>
Auxiliary OV	<input type="checkbox"/>	<input type="checkbox"/>	<input type="checkbox"/>	<input type="checkbox"/>	Disabled	<input type="checkbox"/>	<input type="checkbox"/>	<input type="checkbox"/>	<input type="checkbox"/>	Disabled	<input type="checkbox"/>	<input type="checkbox"/>	<input type="checkbox"/>	<input type="checkbox"/>
Under-frequency 1	<input checked="" type="checkbox"/>	<input type="checkbox"/>	<input type="checkbox"/>	<input checked="" type="checkbox"/>	Trip	<input type="checkbox"/>	<input type="checkbox"/>	<input type="checkbox"/>	<input type="checkbox"/>	Disabled	<input type="checkbox"/>	<input type="checkbox"/>	<input type="checkbox"/>	<input type="checkbox"/>
Under-frequency 2	<input type="checkbox"/>	<input type="checkbox"/>	<input type="checkbox"/>	<input type="checkbox"/>	Disabled	<input type="checkbox"/>	<input type="checkbox"/>	<input type="checkbox"/>	<input type="checkbox"/>	Disabled	<input type="checkbox"/>	<input type="checkbox"/>	<input type="checkbox"/>	<input type="checkbox"/>
Over-frequency 1	<input type="checkbox"/>	<input type="checkbox"/>	<input type="checkbox"/>	<input type="checkbox"/>	Disabled	<input type="checkbox"/>	<input type="checkbox"/>	<input type="checkbox"/>	<input type="checkbox"/>	Disabled	<input type="checkbox"/>	<input type="checkbox"/>	<input type="checkbox"/>	<input type="checkbox"/>
Over-frequency 2	<input type="checkbox"/>	<input type="checkbox"/>	<input type="checkbox"/>	<input type="checkbox"/>	Disabled	<input type="checkbox"/>	<input type="checkbox"/>	<input type="checkbox"/>	<input type="checkbox"/>	Disabled	<input type="checkbox"/>	<input type="checkbox"/>	<input type="checkbox"/>	<input type="checkbox"/>
Cable Thermal Model	<input type="checkbox"/>	<input type="checkbox"/>	<input type="checkbox"/>	<input type="checkbox"/>	Disabled	<input type="checkbox"/>	<input type="checkbox"/>	<input type="checkbox"/>	<input type="checkbox"/>	Disabled	<input type="checkbox"/>	<input type="checkbox"/>	<input type="checkbox"/>	<input type="checkbox"/>

3 Series setup software protection summary for viewing a summary of Protection & Control configuration.

Retrofit Existing Multilin MII Family Devices

Traditionally, retrofitting or upgrading an existing relay has been a challenging and time consuming task often requiring re-engineering, panel modifications and re-wiring. Similar features and form factor of some models of MII family devices allow users to replace their existing relays with 3 Series relays with enhanced protection and control features and advanced communications.

The SR3 Enervista Setup software allows users to create new setting files based on existing MIFII and MIVII setting files and can be uploaded to a 339 relay with a compatible model number. Retrofit is smooth and simplified with minor wiring or switchgear modifications.



SettingName	SettingValue	Original SettingName	Original SettingValue
File			
Relay Information			
ProductName	350	ProductName	MIF
Version	220	Version	303
Notes			
Rest Of the settings are defaulted			
Setpoints			
S1 Relay Setup			
Communications			
RS485			
RS485 Comm Parity	None		
Rear 485 Protocol	Modbus		
Ethernet			
IP Settings			
Ethernet IP address	0		
Ethernet subnet mask	4294966272		
Ethernet gateway address	0		
Transient Recorder			
Transient Buffer Setup	1 x 192		
Trigger Mode	Overwrite		
Trace Memory Trigger Position	8 %		

Wiring Diagram

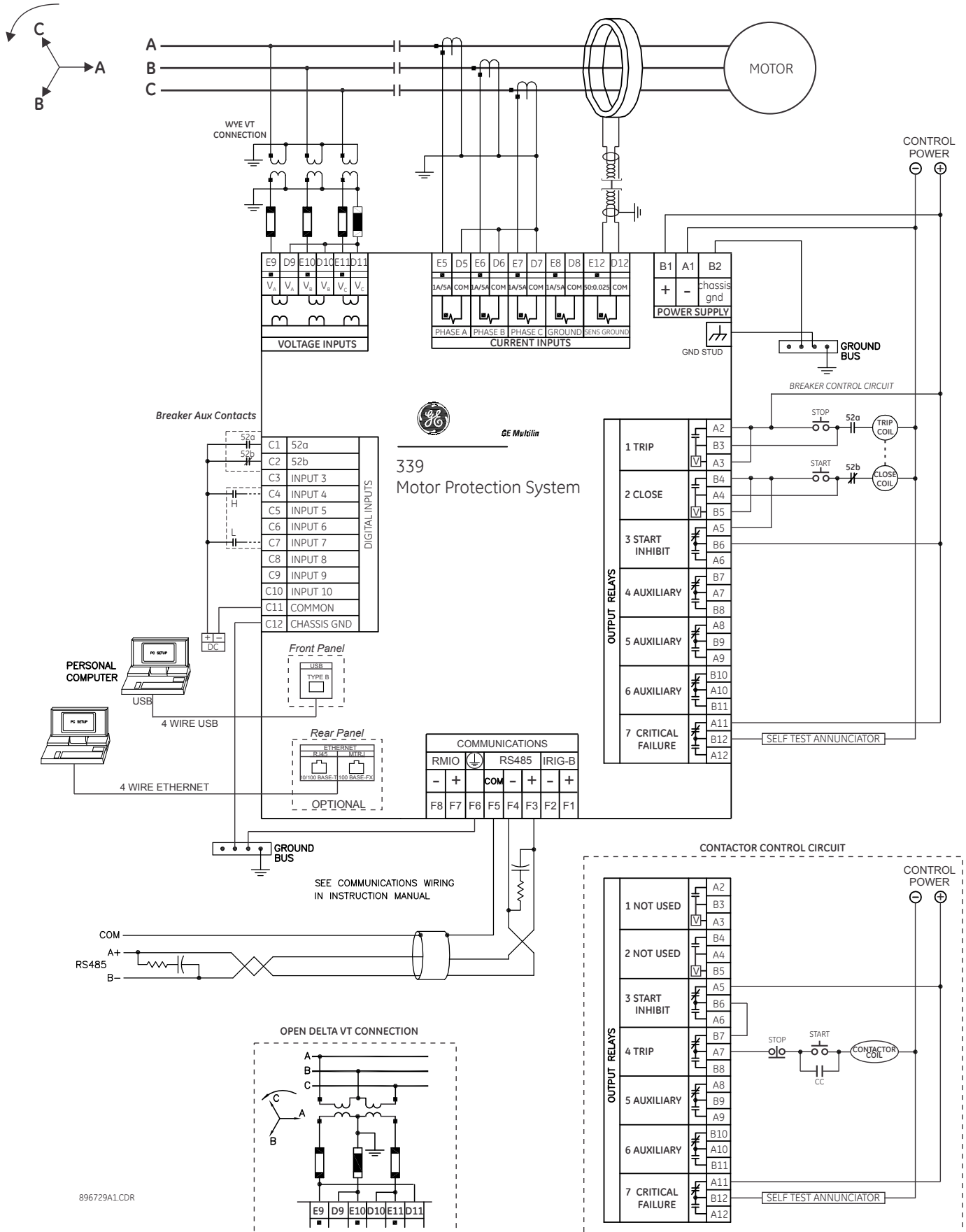

896729A1.CDR

## Technical Specifications

PASSWORD SECURITY	
Master Reset Password:	8 to 10 alpha-numeric characters
Settings Password:	3 to 10 alpha-numeric characters for local or remote access
Control Password:	3 to 10 alpha-numeric characters for local or remote access

NEUTRAL INSTANTANEOUS OVERCURRENT (50N)	
Pickup Level:	0.05 to 20 x CT in steps of 0.01 x CT
Dropout Level:	96 to 99% of Pickup @ I > 1 x CT Pickup - 0.02 x CT @ I < 1 x CT
Time Delay:	0.00 to 300.00 sec in steps of 0.01
Operate Time:	<30 ms @ 60Hz (I > 2.0 x PKP), 0 ms time delay <35 ms @ 50Hz (I > 2.0 x PKP), 0 ms time delay
Timer Accuracy:	0 to 1 cycle
Level Accuracy:	per CT input
Elements:	Trip or Alarm

NEUTRAL DIRECTIONAL OVERCURRENT (67N)	
Directionality:	Co-existing forward and reverse
Polarizing:	Voltage, Current, Dual
Polarizing Voltage:	-V <sub>0</sub> calculated using phase voltages (VTs must be connected in "Wye")
Polarizing Current:	I <sub>0</sub>
MTA:	From 0° to 359° in steps of 1°
Angle Accuracy:	4
Operation Delay:	20 to 30 ms

PHASE/NEUTRAL TIMED OVERCURRENT (51P/51N)	
Pickup Level:	0.05 to 20.00 x CT in steps of 0.01 x CT
Dropout Level:	97% of Pickup @ I > 1 x CT Pickup - 0.02 x CT @ I < 1 x CT
Pickup Curve Shape:	ANSI Extremely/Very/Moderately/Normally Inverse Definite Time (0.1 s base curve) IEC Curve A/B/C and Short Inverse IAC Extremely/Very/-/Short Inverse
Curve Multiplier:	0.05 to 50.00 in steps of 0.01
Reset Time:	Instantaneous, Linear
Curve Timing Accuracy:	±3% of expected inverse time or 1 cycle, whichever is greater, from pickup to operate per CT input

DIRECTIONAL POWER (32)	
Measured power:	3-phase
Characteristic angle:	0° to 359° in steps of 1°
Power pickup range:	-1.200 to 1.200 x Rated Power in steps of 0.001
Pickup level accuracy:	± 1% or ± 0.001 x Rated Power, whichever is greater
Hysteresis:	2% of pickup
Pickup time delay:	0.00 to 600.0 s in steps of 0.1 s
Operate time:	< 55 ms at 1.1 x pickup at 60 Hz < 65 ms at 1.1 x pickup at 50 Hz ± 3% of delay setting or ± ¼ cycle (whichever is greater) from pickup to operate
Timer accuracy:	

UNDERCURRENT (37)	
Pickup Level:	0.1 to 0.95 x FLA in steps of 0.01 x FLA
Dropout Level:	102% of Pickup
Time Delay:	1.00 to 60.00 s in steps of 0.01 s
Block from Start:	0 to 600 s in steps of 1 s
Pickup Accuracy:	as per phase current inputs
Timing Accuracy:	±0.5 s or ± 0.5% of total time
Elements:	Trip or Alarm

CURRENT UNBALANCE (46)	
Unbalance Pickup Level:	4.00 to 40.00% in steps of 0.01%
Trip Curves:	Definite time, Inverse time
Trip TDM:	1.00 to 100.00 s in steps of 0.01 s
Trip Maximum Time:	1.00 to 1000.00 s in steps of 0.01 s
Trip Minimum Time:	1.00 to 1000.00 s in steps of 0.01 s
Trip Reset Time:	1.00 to 1000.00 s in steps of 0.01 s
Alarm Time Delay:	1.00 to 60.00 s in steps of 0.01 s
Single Phasing Pickup Level:	unbalance level > 40% or when Iavg ≥ 25%FLA and current in any phase is less than the cutoff current
Single Phasing Time Delay:	2 sec
Dropout Level:	Pickup - 1
Pickup Accuracy:	±2%
Timing Accuracy:	±0.5 s or ± 0.5% of total time
Unbalance Elements:	Trip and Alarm
Single Phasing Elements:	Trip

RTD (38)	
Pickup:	1 to 250°C in steps of 1°C
Pickup Hysteresis:	2°C
Time Delay:	3 sec
Elements:	Trip and Alarm

RTD TROUBLE ALARM (38)	
RTD Trouble Alarm:	<-50°C or >250°C

LOAD INCREASE ALARM	
Pickup Level:	50 to 150%FLA in steps of 1%FLA
Dropout Level:	2% of pickup
Alarm Time Delay:	1.00 to 60.00 s in steps of 0.01 s
Pickup Accuracy:	as per phase current inputs
Timing Accuracy:	±0.5 s or ±0.5% of total time

SHORT CIRCUIT	
Pickup Level:	1.00 to 20.00 x CT in steps of 0.01 x CT
Dropout Level:	97% of Pickup @ I > 1 x CT Pickup - 0.02 x CT @ I < 1 x CT
Alarm Time Delay:	0.00 to 60.00 s in steps of 0.01 s
Pickup Accuracy:	as per phase current inputs
Operate Time:	<30 ms @ 60Hz (I > 2.0 x PKP), 0 ms time delay <35 ms @ 50Hz (I > 2.0 x PKP), 0 ms time delay

Timing Accuracy:	0 to 1 cycle
Elements:	Trip or Alarm

MECHANICAL JAM TRIP (51R)	
Pickup Level:	1.01 to 4.50 x FLA in steps of 0.01 x FLA, blocked from start
Dropout Level:	98% of pickup (pickup > 0.50) Pickup - 0.01 (pickup ≤ 0.50)
Trip Time Delay:	0.10 to 30.00 s in steps of 0.01 s
Pickup Accuracy:	as per phase current inputs
Timing Accuracy:	±0.5 s or ±0.5% of total time

GROUND FAULT/SENSITIVE GROUND FAULT (CBCT) (50G/SG)	
Pickup Level:	0.03 to 1.00 x CT in steps of 0.01 x CT 0.50 to 15.00 A in steps of 0.01 A (CBCT)
Dropout Level:	Pickup - 0.01 x CT Pickup - 0.03 x CT (CBCT)
Alarm Time Delay on Run:	0.00 to 60.00 s in steps of 0.01 s
Alarm Time Delay on Start:	0.00 to 60.00 s in steps of 0.01 s
Trip Time Delay on Run:	0.00 to 5.00 s in steps of 0.01 s
Trip Time Delay on Start:	0.00 to 10.00 s in steps of 0.01 s
Pickup Accuracy:	as per ground current inputs
Operate Time:	<30 ms @ 60Hz (I > 2.0 x PKP), 0 ms time delay <35 ms @ 50Hz (I > 2.0 x PKP), 0 ms time delay
Timing Accuracy:	0 to 1 cycle
Elements:	Trip and Alarm

UNDERPOWER (37)	
Pickup Level:	1 to 100% Hz MNR 1%
Dropout Level:	101% to 104% of Pickup
Time Delay:	1.0 to 60.0 s in steps of 0.1
Pickup Accuracy:	as per power monitoring specification
Timing Accuracy:	±0.5 s or ±0.5% of total time
Elements:	Trip and Alarm

THERMAL PROTECTION (49)	
Locked Rotor Current:	2.0 to 11.0 x FLA in steps of 0.1 x FLA
Safe Stall Time:	1.0 to 600.0 s in steps of 0.1 s
Curve Multiplier:	1 to 15 in steps of 1
Pickup Level:	1.01 to 1.25 x FLA in steps of 0.01 x FLA
Curve Biasing:	Phase unbalance Hot/cold biasing Stator RTD biasing Exponential Running and Stopped Cooling Rates
TCU Update Rate:	3 cycles
Pickup Accuracy:	per phase current inputs
Timing Accuracy:	± 200 ms or ±2% of total time
Elements:	Trip and Alarm

PHASE/AUXILIARY UNDERVOLTAGE (27P/27X)	
Minimum Voltage:	Programmable from 0.00 to 1.25 x VT in steps of 0.01
Pickup Level:	0.00 to 1.25 x VT in steps of 0.01
Dropout Level:	102% of pickup for pickup > 0.1 x VT Pickup + 0.02 x VT for pickup < 0.1 x VT
Curve:	Definite Time, Inverse Time
Time Delay:	0.00 to 600.00 s in steps of 0.01
Operate Time:	Time delay ±30 ms @ 60 Hz (V < 0.85 x PKP) Time delay ±40 ms @ 50 Hz (V < 0.85 x PKP)
Time Delay Accuracy:	±3% of expected time, or 1 cycle, whichever is greater
Level Accuracy:	Per voltage input

NEGATIVE SEQUENCE/PHASE OVERVOLTAGE (59P/59_2)	
Pickup Level:	0.00 to 1.25 x VT in steps of 0.01
Dropout Level:	98% of pickup for pickup > 0.1 x VT Pickup - 0.02 x VT for pickup < 0.1 x VT
Time Delay:	0.00 to 600.00 s in steps of 0.01
Operate Time:	Time delay ±30 ms @ 60 Hz (V < 0.85 x PKP) Time delay ±40 ms @ 50 Hz (V > 1.1 x PKP)
Timing Accuracy:	±3% of expected time, or 1 cycle, whichever is greater
Level Accuracy:	Per voltage input

PHASE REVERSAL (47)	
Configuration:	ABC or ACB phase rotation
Time Delay:	100 ms
Timing Accuracy:	±0.5 s
Elements:	Trip or Alarm

UNDERFREQUENCY (81U)	
Minimum Voltage:	0.00 to 1.25 x VT in steps of 0.01
Pickup Level:	40.00 to 70.00 Hz in steps of 0.01
Dropout Level:	Pickup +0.05 Hz
Time Delay:	0.1 to 600.0 s in steps of 0.01
Timing Accuracy:	±0.5 s or ±0.5% of total time
Level Accuracy:	±0.05 Hz
Elements:	Trip and Alarm

OVERFREQUENCY (81O)	
Minimum Voltage:	0.3 x VT
Pickup Level:	40.00 to 70.00 Hz in steps of 0.01
Dropout Level:	Pickup -0.05 Hz
Time Delay:	0.1 to 600.0 s in steps of 0.01
Timing Accuracy:	±0.5 s or ±0.5% of total time
Level Accuracy:	±0.05 Hz
Elements:	Trip and Alarm

ACCELERATION TIME TRIP (48)	
Pickup Level:	Motor start condition
Dropout Level:	Motor run, trip, or stop condition
Timers for single-speed:	Stopped to running
Timers for two-speed:	Stopped to high speed, stopped to low speed, low to high speed
Time Delay:	1.0 to 250.0 s in steps of 0.1
Timing Accuracy:	±200 ms or ±1% of total time

MOTOR START DATA LOGGER	
Length:	6 buffers, containing a total of 30 seconds of motor starting data
Trigger:	Motor start status
Trigger Position:	1-second pre-trigger duration
Logging Rate:	1 sample/200 ms

FUSE FAIL (VTFF)	
Time Delay:	1 s
Timing Accuracy:	±0.5 s
Elements:	Trip or Alarm

FAULT RECORDER	
Number of records:	1
Content:	Date and Time, first cause of fault, phases
Current:	Ia, Ib, Ic, Ig/Is, In - magnitudes and angles
Voltages:	Van, Vbn, Vcn, Vab, Vbc, Vca, Vaux - magnitudes and angles

TRANSIENT RECORDER	
System frequency	
Buffer size:	3 s
No. of buffers:	1, 3, 6
No. of channels:	14
Sampling rate:	4, 8, 16, or 32 samples per cycle
Triggers:	Manual Command Contact Input Virtual Input Logic Element Element Pickup/Trip/Dropout/Alarm
Data:	AC input channels Contact input state Contact output state Virtual input state Logic element state
Data storage:	RAM - battery backed-up

EVENT RECORDER	
Number of events:	256
Content:	event number, date of event, cause of event, per-phase current, ground current, sensitive ground current, neutral current, per-phase voltage (VTs connected in "Wye"), or phase-phase voltages (VTs connected in "Delta"), system frequency, power, power factor, thermal capacity, motor load, current unbalance
Data Storage:	Non-volatile memory

LEARNED DATA RECORDER	
Number of events:	250
Header:	Date, number of records
Content:	learned acceleration time, learned starting current, learned starting capacity, last starting current, last starting capacity, last acceleration time, average motor load learned, average run time after start (days), average run time after start (minutes)
Data Storage:	Non-volatile memory

## Technical Specifications

<b>CLOCK</b>			
Setup:	Date and time Daylight Saving Time		
IRIG-B:	Auto-detect (DC shift or Amplitude Modulated) Amplitude modulated: 1 to 10 V pk-pk DC shift: 1 to 10 V DC Input impedance: 40 kOhm ± 10%		
Accuracy with IRIG-B:	± 1 ms		
Accuracy without IRIG-B:	± 1 minute/month		
<b>LOGIC ELEMENTS</b>			
Number of logic elements:	16		
Trigger source inputs per element:	2 to 8		
Block inputs per element:	2 to 4		
Supported operations:	AND, OR, NOR, NAND, XOR, XNOR, Pickup / Dropout timers		
Pickup timer:	0 to 60000 ms in steps of 1 ms		
Dropout timer:	0 to 60000 ms in steps of 1 ms		
<b>BREAKER CONTROL</b>			
Operation:	Asserted Contact Input, Logic Element, Virtual Input, Manual Command, Remote Input		
Function:	Opens/closes the motor breaker		
<b>START INHIBIT</b>			
Thermal Start Inhibit:	Thermal Inhibit Margin: 0 to 25 % in steps of 1%		
Starts per Hour Inhibit:	Maximum: 1 to 5 starts in steps of 1		
Time Between Starts Inhibit:	Time Between Starts: 1 to 3600 s in steps of 1 s		
Restart Inhibit:	Restart Inhibit Delay: 1 to 50000 s in steps of 1 s		
<b>BREAKER FAILURE/WELDED CONTACTOR</b>			
Current Supervision:	Phase Current		
Current Supervision Pickup:	0.05 to 20.00 × CT in steps of 0.01 × CT		
Time Delay 1:	0.03 to 1.00 s in steps of 0.01 s		
Time Delay 2:	0.00 to 1.00 s in steps of 0.01 s		
Current Supervision Dropout:	97 to 98% of pickup		
Current Supervision Accuracy:	per CT input		
Reset Time:	<14 ms typical at 2 × pickup at 60 Hz <16 ms typical at 2 × pickup at 50 Hz		
Timing Accuracy:	0 to 1 cycle (Timer 1, Timer 2)		
<b>BREAKER TRIP COUNTER</b>			
Trip Counter Limit (Pickup):	1 to 10000 in steps of 1		
<b>CT FAILURE (60CTS)</b>			
Inputs:	Neutral Current IN, Neutral Current VN (from three-phase VTs) Ground Current Ig		
Time Delay:	0.00 to 60.00 s in steps of 0.01 s		
3I0 level accuracy:	per CT inputs		
3V0 level accuracy:	per VT inputs		
GND current level accuracy:	see the specifications for phase and ground current inputs		
Operate Time:	30 ms at 60 Hz 35 ms at 50 Hz		
<b>EMERGENCY RESTART</b>			
Function:	Defeats all motor start inhibit features, resets all trips and alarms, and discharges the thermal capacity to zero so that a hot motor can be restarted in the event of an emergency		
Operation:	Contact Input 1 to 10, Virtual Input 1 to 32, Logic Element 1 to 16, Remote Input 1 to 32		
<b>LOCKOUT RESET</b>			
Function:	Reset any lockout trips when this feature is configured		
Operation:	Contact Input 1 to 10, Virtual Input 1 to 32, Logic Element 1 to 16, Remote Input 1 to 32		
<b>RESET</b>			
Function:	Resets any alarms and non-lockout trips when LOCKOUT RESET is configured, or resets any alarms and trips (lockout and non-lockout trips) when LOCKOUT RESET is not configured.		
Operation:	Contact Input 1 to 10, Virtual Input 1 to 32, Logic Element 1 to 16, Remote Input 1 to 32		
<b>AMBIENT TEMPERATURE</b>			
High Temperature Pickup:	20°C to 80°C in steps of 1°C		
Low Temperature Pickup:	-40°C to 20°C in steps of 1°C		
Time Delay:	1 to 60 min in steps of 1 mins		
Temperature Dropout:	Configurable 90 to 98% of pickup		
Temperature Accuracy:	±10°C		
Timing Accuracy:	±1 second		
<b>BREAKER HEALTH</b>			
Timer Accuracy:	± 3% of delay setting or ± 1 cycle (whichever is greater) from pickup to operate		
<b>DEMAND</b>			
Measured Values:	Phase A/B/C present and maximum current, three-phase Thermal Exponential, 90% response time (programmed): 5, 10, 15, 20, 30 minutes		
present and maximum real/reactive/apparent power Measurement Type	5, 10, 15, 20, 30 minutes		
Block Interval / Rolling Demand, time interval (programmed):	10 to 10000 in steps of 1 A		
Current Pickup Level:	0.1 to 300000.0 in steps of 0.1 kW Level:		
Real Power Pickup Level:	0.1 to 300000.0 in steps of 0.1 kVar		
Reactive Power Pickup Level:	0.1 to 300000.0 in steps of 0.1 kVA		
Apparent Power Pickup Level:	96-98% of Pickup level		
Dropout Level:	Level Accuracy: ± 2% (current demand only)		
Level Accuracy:			
<b>CONTACT INPUTS</b>			
Inputs:	10		
Selectable thresholds:	17, 33, 84, 166 VDC		
Tolerance:	±10%		
Recognition time:	1/2 cycle		
Bounce time:	1 to 64 ms, selectable, in steps of 1 ms		
Maximum input voltage & continuous current draw	300 VDC, 2 mA, connected to Class 2 source		
Type:	opto-isolated inputs		
External switch:	wet contact		
<b>CBCT INPUT (50:0.025)</b>			
Range:	0.5 to 15.0 A		
Nominal frequency:	50 or 60 Hz		
Accuracy (CBCT):	±0.1 A (0.5 to 3.99 A) ±0.2 A (4.0 A to 15 A)		
<b>PHASE VOLTAGE INPUTS</b>			
Source VT:	100 to 20000 V		
VT secondary range:	50 to 240 V		
VT ratio:	1 to 300 in steps of 1		
Nominal frequency:	50/60 Hz		
Relay burden:	<0.25 VA at 120 V		
Accuracy:	±1.0% throughout range		
Voltage withstand:	260 VAC continuous		
<b>PHASE &amp; GROUND CURRENT INPUTS</b>			
CT Primary:	30 to 1500 A		
Range:	0.02 to 20 × CT		
Input type:	1 A or 5 A (must be specified with order)		
Nominal frequency:	50/60 Hz		
Burden:	<0.1 VA at rated load		
Accuracy:	±3% of reading from 0.2 to 20 × CT +/- 10 mA or ±20% of reading from 0.02 to 0.19 × CT, whichever is greater		
CT withstand:	1 second at 100 A (1 A option) 1 second at 400 A (5 A or universal CT option) 2 seconds at 40 × rated current continuous at 3 × rated current		
<b>FREQUENCY</b>			
Accuracy:	±0.05 Hz		
Resolution:	0.01 Hz		
Range:	40.00 to 70.00 Hz		
<b>RTD INPUTS</b>			
RTD Type:	100 Ohm platinum (DIN.43760)		
RTD Sensing Current:	5 mA		
Isolation:	2 kV from base unit (RMIO only)		
Distance:	250 m maximum		
Range:	-50 to +250°C		
Accuracy:	±3°C		
Lead Resistance:	25 Ohm max per lead		
RTD Trouble Alarm	<-50 or >250 °C		
RTD Inputs Available	3 with INPUT/OUTPUT option 'R' installed OR 12 maximum with the RMIO option connected		
<b>FORM-A VOLTAGE MONITOR</b>			
Applicable voltage:	20 to 250 VDC		
Trickle current:	1 to 2.5 mA		
<b>FORM-A RELAYS</b>			
Configuration:	2 (two) electromechanical (one if internal RTD is selected) silver-alloy		
Contact material:	silver-alloy		
Operate time:	<8 ms		
Continuous current:	10 A		
Make and carry for 0.2s:	30 A per ANSI C37.90		
Break (DC inductive, L/R=40 ms):	24 V / 1 A 48 V / 0.5 A 125 V / 0.3 A 250 V / 0.2 A		
Break (DC resistive):	24 V / 10 A 48 V / 6 A 125 V / 0.5 A 250 V / 0.3 A		
Break (AC inductive):	720 VA @ 250 VAC Pilot duty A300		
Break (AC resistive):	250 VAC / 10 A		
<b>TRIP / CLOSE SEAL-IN</b>			
Relay 1 trip seal-in:	0.00 to 9.99 s in steps of 0.01		
Relay 2 close seal-in:	0.00 to 9.99 s in steps of 0.01		
<b>HIGH RANGE POWER SUPPLY</b>			
Nominal:	120 to 240 VAC 125 to 250 VDC		
Range:	60 to 300 VAC (50 and 60 Hz) 84 to 250 VDC		
Ride-through time:	35 ms		
<b>LOW RANGE POWER SUPPLY</b>			
Nominal:	24 to 48 VDC		
Range:	20 to 60 VDC		
<b>ALL RANGES</b>			
Voltage withstand:	2 × highest nominal voltage for 10 ms		
Power consumption:	15 W nominal, 20 W maximum 20 VA nominal, 28 VA maximum		
Fuse rating:	5A fuse; time lag, slow blow, 350V 4.5 O.D. X 14.5mm		
<b>METERING SPECIFICATIONS</b>			
Parameter	Accuracy	Resolution	Range
3-Phase Real Power (kW)	±1% of full scale	0.1 MW	±100000.0 kW
3-Phase Reactive Power (kvar)	±1% of full scale	0.1 Mvar	±100000.0 kvar
3-Phase Apparent Power (kVA)	±1% of full scale	0.1 MVA	100000.0 kVA
3-Phase Positive Watthour (MWh)	±1% of full scale	±0.001 MWh	50000.0 MWh
3-Phase Negative Watthour (MWh)	±1% of full scale	±0.001 MWh	50000.0 MWh
3-Phase Positive Varhour (Mvarh)	±1% of full scale	±0.001 Mvarh	50000.0 Mvarh
3-Phase Negative Varhour (Mvarh)	±1% of full scale	±0.001 Mvarh	50000.0 Mvarh
Power Factor	±0.05	0.01	-0.99 to 1.00
Frequency	±0.05 Hz	0.01 Hz	40.00 to 70.00 Hz

## Technical Specifications

### FORM-C RELAYS

<b>Configuration:</b>	5 (five) electromechanical (three if internal RTD is selected)
<b>Contact material:</b>	silver-alloy
<b>Operate time:</b>	<8 ms
<b>Continuous current:</b>	10 A
<b>Make and carry for 0.2s:</b>	30 A per ANSI C37.90
<b>Break (DC inductive, L/R=40 ms):</b>	24 V / 1 A 48 V / 0.5 A 125 V / 0.3 A 250 V / 0.2 A
<b>Break (DC resistive):</b>	24 V / 10 A 48 V / 6 A 125 V / 0.5 A 250 V / 0.3 A
<b>Break (AC inductive):</b>	720 VA @ 250 VAC Pilot duty A300
<b>Break (AC resistive):</b>	250 VAC / 10 A

### SERIAL

<b>RS485 port:</b>	Opto-coupled
<b>Baud rates:</b>	up to 115 kbps
<b>Response time:</b>	1 ms typical
<b>Parity:</b>	None, Odd, Even
<b>Maximum Distance:</b>	1200 m (4000 feet)
<b>Isolation:</b>	2 kV
<b>Protocol:</b>	Modbus RTU, DNP 3.0, IEC 60870-5-103

### ETHERNET (COPPER)

<b>Modes:</b>	10/100 MB (auto-detect)
<b>Connector:</b>	RJ-45
<b>Protocol:</b>	Modbus TCP/IP, DNP 3.0, IEC 60870-5-104, IEC 61850 GOOSE, IEC 61850

### ETHERNET (FIBER)

<b>Fiber type:</b>	100 MB Multi-mode
<b>Wavelength:</b>	1300 nm
<b>Connector:</b>	MTRJ
<b>Transmit power:</b>	-20 dBm
<b>Receiver sensitivity:</b>	-31 dBm
<b>Power budget:</b>	9 dB
<b>Maximum input power:</b>	-11.8 dBm
<b>Typical distance:</b>	2 km (1.25 miles)
<b>Duplex:</b>	half/full
<b>Protocol:</b>	Modbus TCP/IP, DNP 3.0, IEC 60870-5-104, IEC 61850 GOOSE, IEC 61850

### USB

<b>Standard specification:</b>	Compliant with USB 2.0
<b>Data transfer rate:</b>	115 kbps

### CAN (RMIO)

<b>Maximum distance:</b>	250 m (820 feet)
<b>Cable type:</b>	Shielded or unshielded twisted pair
<b>Cable gauge</b>	Belden 9841 or similar 24 AWG for distances up to 100 m; 22 AWG for distances up to 250 m

### DIMENSIONS

<b>Size:</b>	Refer to Dimensions section
--------------	-----------------------------

### NON-DRAWOUT UNIT

<b>Weight (net):</b>	2.9 kg (6.4 lbs)
<b>Weight (gross):</b>	4.0 kg (8.6 lbs)

### DRAWOUT UNIT

<b>Weight (net):</b>	3.9 kg (8.6 lbs)
<b>Weight (gross):</b>	5.0 kg (11.0 lbs)

### CERTIFICATION

	Applicable council directive according to low voltage directive 2014/35/EU
<b>CE:</b>	EMC Directive 2014/30/EU, UL508
<b>ISO:</b>	Manufactured under a registered quality program ISO9001
<b>EAC:</b>	Machines and Equipment TR CU 010/2011
<b>LLOYD's Register</b>	Rules and regulations for the classifications of Ships, Marine applications: ENV2, ENV3

### EAC

	The EAC Technical Regulations (TR) for Machines and Equipment apply to the Customs Union (CU) of the Russian Federation, Belarus, and Kazakhstan
<b>Country of origin</b>	Spain or Canada; see label on the unit
<b>Date of manufacture</b>	See label on the side of the unit
<b>Declaration of Conformity and/ or Certificate of Conformity</b>	Available upon request

### TEST REFERENCE STANDARD TEST LEVEL

<b>Dielectric voltage withstand</b>		
<b>high voltage power supply*</b>	60255-27	2200 VAC for one second
<b>low voltage power supply*</b>	60255-27	550 VAC for one second
<b>Impulse voltage withstand</b>	EN60255-27	5kV
<b>Damped Oscillatory</b>	IEC 60255-26 / IEC 61000-4-18	2.5kV CM, 1 kV DM
<b>Electrostatic Discharge</b>	IEC 60255-26 / IEC 61000-4-2	15 kV / 8 kV
<b>RF immunity</b>	IEC 60255-26 / IEC 61000-4-3	80 MHz- 1 GHz, 1.4 Ghz-2.7Ghz, 10 V/m
<b>Fast Transient Disturbance</b>	IEC 60255-26 / IEC 61000-4-4	2 or 4 kV
<b>Surge Immunity</b>	IEC 60255-26 / IEC 61000-4-5	0.5, 1 & 2 kV
<b>Conducted RF Immunity</b>	IEC 60255-26 / IEC 61000-4-6	150 kHz-80 MHz, 26-68 MHz, 10V/m
<b>Voltage interruption &amp; Ripple DC</b>	IEC 60255-26 / IEC 61000-4-11	15% ripple, 200ms interrupts Class A
<b>Radiated &amp; Conducted Emissions</b>	CISPR11 / CISPR22 / IEC 60255-26: Section 7.1.2 & 7.1.3	
<b>Sinusoidal Vibration</b>	IEC 60255-21-1	Class 1
<b>Shock &amp; Bump</b>	IEC 60255-21-2	Class 1
<b>Seismic</b>	IEC 60255-21-3	Class 2
<b>Power magnetic Immunity</b>	IEC 60255-26 / IEC 61000-4-8	1000 A/m, 100 A/m, 30A/m 300 A/m
<b>Voltage Dip &amp; interruption</b>	IEC 60255-26 / IEC 61000-4-11	0, 40, 70, 80% dips, 250/300 cycle interrupts Level 4
<b>Power frequency</b>	IEC 60255-26 / IEC 61000-4-16	
<b>Voltage Ripple</b>	IEC 60255-26 / IEC 61000-4-17	15% ripple
<b>Ingress Protection</b>	IEC 60529	IP54 front, IP10 Back
<b>Environmental (Cold)</b>	IEC 60068-2-1	-40°C 16 hrs
<b>Environmental (Dry heat)</b>	IEC 60068-2-2	85°C 16hrs
<b>Relative Humidity Cyclic</b>	IEC 60068-2-30	6 day variant 2
<b>EFT</b>	IEEE / ANSI C37.90.1	4KV, 2.5Khz
<b>Damped Oscillatory RF Immunity</b>	IEEE / ANSI C37.90.1	2.5KV, 1Mhz
	IEEE / ANSI C37.90.2	35V/m (max field), (80 MHz-1 GHz with 1 KHz sine and 80% AM modulation)
<b>ESD</b>	IEEE / ANSI C37.90.3	8KV CD/ 15KV AD
<b>Safety</b>	UL 508	e83849 NKCR
	UL C22.2-14	e83849 NKCR7
	UL 1053	e83849 NKCR

\* Test level is based on basic insulation principle (Power supply I/P terminals tested to Chassis ground).

### OPERATING ENVIRONMENT

<b>Ambient operating temperature:</b>	-40°C to +60°C [-40°F to +140°F]
<b>Ambient storage / shipping temperature:</b>	-40°C to +85°C [-40°F to +185°F]
<b>Humidity:</b>	Operating up to 95% (non condensing) @ 55C (As per IEC 60068-2-30 Variant 2, 6days)
<b>Altitude:</b>	2000 m (max)
<b>Pollution degree:</b>	II
<b>Overvoltage category:</b>	III
<b>Ingress Protection:</b>	IP54 Front, IP10 back (IP20 cover is available for drawout version)
<b>Noise:</b>	0 dB

## Ordering

	339	-	*	*	*	*	*	S	N	*	*	*	*	*	Description
Interface	339														339 Motor Protection System
Language <sup>a</sup>			E												English without programmable LEDs English with programmable LEDs
Phase Currents <sup>b</sup>				P0											1 A or 5 A configurable phase current inputs 1 A 3-phase current inputs 5 A 3-phase current inputs
Ground Currents <sup>c</sup>					G0										1 A or 5 A configurable ground current input 1 A ground current input 5 A ground current input
Power Supply						L									24 to 48 V DC 125 to 250 V DC/120 to 240 V AC
Input/Output <sup>d</sup>							H								10 Contact Inputs, 7 Outputs (2 Form A, 5 Form C) 10 Contact Inputs, 4 Outputs (1 Form A, 3 Form C), 3 100 Ohm Platinum RTD Inputs
Current Protection															Standard configuration: 37, 46, 48, 49, 50P(1), 50G/SG(1), 50N(1), 50L, 51R, 66, 86, 51N(1), 51P(1), 50BF
Other Options															No Selection Voltage, Power, Energy Metering, VTFF (1), 60CTS Voltage Protection: 37P, 27P(2), 27P_1(2), 47(1), VTFF(1), 59P(2), 81O(2), 81U(2), 59_2(1), 67N(1), 32(2), 60CTS, Voltage, Power, Energy Metering
Communications											S	N			Standard: Front USB, Rear RS485: Modbus RTU, DNP3.0, IEC60870-5-103 Standard + Ethernet (Copper + Fiber - MTRJ) Modbus TCP/IP, DNP3.0, IEC 60870-5-104 Standard + Ethernet (Copper + Fiber - MTRJ) Modbus TCP/IP, DNP3.0, IEC 60870-5-104, IEC 61850
Case Design															D Protection Relay with drawout design N Protection Relay with non-drawout design X Protection Relay (drawout design) with no chassis
Harsh Environment															N None H Harsh Environment Conformal Coating

### Ordering Notes:

- <sup>a</sup> Phase current option "P0" and Ground current option "G0" is only available on the non-drawout version (Case Design option "N")
- <sup>b</sup> Ground current options "G0/G1/G5" must match the corresponding "P0/P1/P5" Phase currents
- <sup>c</sup> The Input/Output option "R" is only available on the drawout version (Case Design option D) and High voltage power supply (Power Supply option H). The 339 does not support both internal RTDs and RMIO RTDs simultaneously.

	345	CH	*	*	S	N	*	*	*	*	Description
Phase Currents			P1								1 A 3-phase CTs (Winding 1 - 1 A, Winding 2 - 1 A) 5 A 3-phase CTs (Winding 1 - 5 A, Winding 2 - 5 A)
Ground Currents <sup>a</sup>				G1							1 A standard ground CTs (Winding 1 - 1 A, Winding 2 - 1 A) 5 A standard ground CTs (Winding 1 - 5 A, Winding 2 - 5 A)
Other Options											No Selection Voltage, Power, Energy Metering, VTFF (1), 60CTS Voltage Protection: 37P, 27P(2), 27P_1(2), 47(1), VTFF(1), 59P(2), 81O(2), 81U(2), 59_2(1), 67N(1), 32(2), 60CTS
Communications								S	N		Standard: Front USB, Rear RS485: Modbus RTU, DNP3.0, IEC60870-5-103 Standard + Ethernet (Copper + Fiber - MTRJ) Modbus TCP/IP, DNP3.0, IEC 60870-5-104 Standard + Ethernet (Copper + Fiber - MTRJ) Modbus TCP/IP, DNP3.0, IEC 60870-5-104, IEC 61850
Harsh Environment											N None H Harsh Environment Conformal Coating

- <sup>a</sup> Ground current options "G1/G5" must match the corresponding "P1/P5" Phase currents

### Ordering Notes:

A drawout relay cannot be used in a chassis with different order code options.

	RMIO	*	G	G	*	*	Description
Power Supply		L					24 - 48 V DC 110 - 250 V DC / 110 - 230 V AC
I/O Module 1			G				Remote Module I/O (3 - 100 Ohm Platinum RTDs)
I/O Module 2				G			Remote Module I/O (3 - 100 Ohm Platinum RTDs)
I/O Module 3 <sup>a</sup>					G		Remote Module I/O (3 - 100 Ohm Platinum RTDs)
					X		None
I/O Module 4						G	Remote Module I/O (3 - 100 Ohm Platinum RTDs)
						X	None

- <sup>a</sup> RMIO comes standard with 6 RTDs (Modules 1 and 2). The 9 and 12 RTD options (Modules 3 and 4) require firmware 1.40 or greater.

### Accessories for the 339

- SR3 Depth Reducing Collar Kit - 1.375 18L0-0075
- SR3 Depth Reducing Collar Kit - 3.00 18L0-0076
- 18L0-0080 SR3 IP20 Kit
- 0804-0458 USB configuration cable
- 18L1-0041 NDO straight connectors

## Grid Solutions

650 Markland St.  
Markham, ON  
Canada L6C 0M1

Toll Free (NA Only): 1-800-547-8629  
Tel: 905-927-7070  
Fax: 905-927-5098

[GEGridSolutions.com](http://GEGridSolutions.com)

IEC is a registered trademark of Commission Electrotechnique Internationale. IEEE is a registered trademark of the Institute of Electrical Electronics Engineers, Inc. Modbus is a registered trademark of Schneider Automation. NERC is a registered trademark of North American Electric Reliability Council. ANSI is a registered trademark of American National Standards.

GE, the GE monogram, Multilin, FlexCurves and EnerVista are trademarks of General Electric Company.

GE reserves the right to make changes to specifications of products described at any time without notice and without obligation to notify any person of such changes.

Copyright 2018, General Electric Company. All Rights Reserved.

GEA-127790(E)  
English  
180228



imagination at work