

DC CAPACITORS

Product Selection & Application Guide
Capacitors for High Current, Power
Semiconductor and DC Applications



Product Selection & Application Guide

Capacitors for power electronics require special high performance designs for varied applications. This catalog describes capacitors for a number of demanding applications where high currents and/ or high voltages are common. Given the special nature of these types of applications, care must be taken to ensure that the capacitors are correctly applied. Information is included to help with the more common application conditions. An application data sheet is also provided to enlist the help of GE Vernova's Application Engineers. Please use this sheet if you need assistance or want to verify your own calculations.



Table of Contents

Description	Page	Information
Application Data Sheet	3	Use this sheet to submit data to GE Vernova for review
Descriptive Information	4	General information on capacitor construction
SCR Commutation Capacitors	5	High and very high current applications, such as SCR commutation, SCR and GTO snubbers, and high frequency AC circuits
Snubber Capacitors	10	Medium current snubber capacitors for Power Semiconductor circuits
Application Data for SCR and Snubber capacitors	12	Derating information for current Pulsewidth and temperature. Examples for common conditions
General Purpose DC Capacitors	14	DC capacitors for voltages up to 2500 V
Hardware and Accessories	16	Mounting Hardware

Application and Selection Guide

Capacitor Application Data Sheet

To ensure correct selection of a capacitor for your application, please provide the information indicated below. This sheet may be duplicated or additional copies may be obtained from GE Vernova. Of particular importance are the voltage and current waveforms complete with values of voltage and current over a complete cycle.

Send this data to your local GE Vernova Sales Office or directly to:

Grid Solutions at GE Vernova LLC
 Capacitor & Power Quality Products
 1925 Calumet Street
 Clearwater, FL 33765

Attn: Industrial Capacitor Sales

Primary Information (Essential)

Company Name Address _____ Tel No. (Incl. Country & City codes) _____
 Address _____ FAX No. _____
 Person to contact _____
 1. Application _____
 2. Capacitance _____ Tolerance: _____
 3. Peak Voltage _____ RMS Voltage _____ Voltage Reversal (%) _____
 4. Peak Current _____ RMS Current _____
 5. Transient Voltage _____ Duration _____ Freq. of Occurrence _____
 6. Frequency or Repetition Rate (Hz) _____ Duty Cycle _____
 7. Ambient Temperature _____ Max. _____ Min. _____
 8. Capacitor Charge Time _____ Discharge Time _____
 9. Required Operating Life (Hours) _____
 10. Waveforms

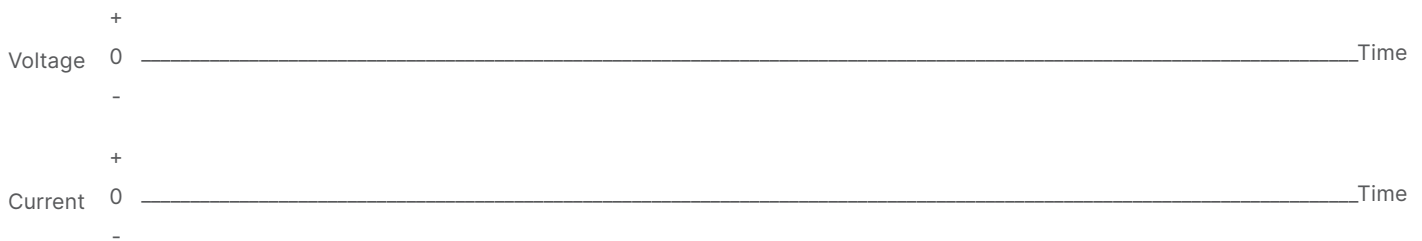

SECONDARY INFORMATION (Provide as Appropriate)

11. Physical Size Limitations _____
 12. Mounting Requirements _____
 13. Applicable Specifications _____
 14. Type of Cooling Available _____
 15. Unusual Atmospheric Conditions _____
 16. Other Special Requirements _____
 17. Potential Usage _____

Descriptive Information

Film Foil Electrode Construction

GE Vernova's Foil Electrode capacitors are manufactured with sheets of high quality aluminum foil as the electrodes. The dielectric consists of two sheets of polypropylene film. The film is manufactured in GE Vernova's own Capacitor Materials Operation. It is specially designed with a rough surface to allow impregnation by the dielectric fluid. The aluminum foil electrodes extend, one on each end of the capacitor roll, so that a solder connection can be made. Depending on the typical current for the type of capacitor, the internal connections from the roll ends to the terminals are either braided cables or tin-plated copper straps. This construction provides capacitors that are inherently capable of handling high RMS and peak currents.

Dielectric Fluids

GE Vernova's dielectric fluids are chosen for specific characteristics that match the other components in the capacitor dielectric system and the applications for which the capacitors are intended. Each fluid is based on one or two major constituents and blended with proprietary additives for optimum performance.

DIELEKTROL VII

A Benzyl Toluene-based fluid used for film/foil high current products.

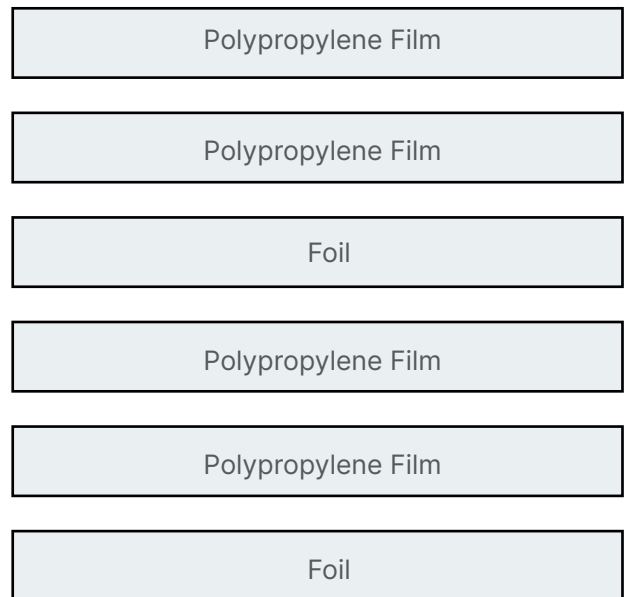
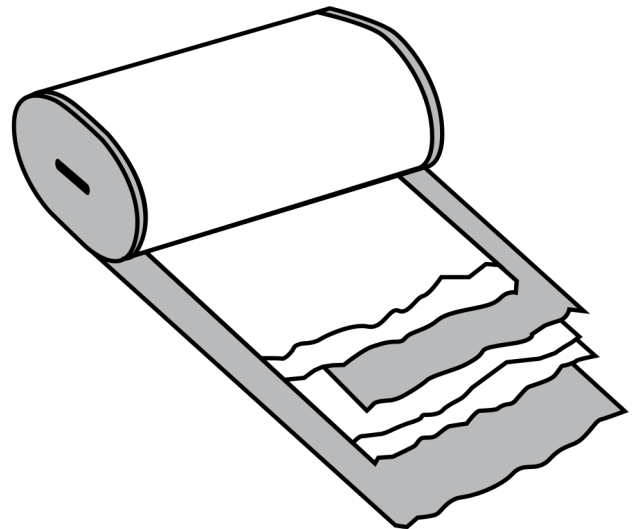

SCR Commutation Capacitors

A97F8600 / A97F8700 Series 600 to 1500 Volts Peak

This family of capacitors is designed for high-current applications, such as (1) SCR commutation, (2) snubbers for SCRs, GTOs and other power semiconductors, and (3) for any other circuits where the combination of frequency and voltage results in high RMS currents. An Application Note is provided to assist in the proper use of these devices. It is strongly recommended that users refer to GE Vernova engineers for assistance if there are any questions as to the correct selection of capacitors. The A97F8600/A97F8700 Series have an all-film dielectric and, due to the much lower dissipation factor, can handle much higher currents than the older film paper designs.

Advances in capacitor Dielectric technology have made paint unnecessary, in most cases. This along with GE Vernova's commitment to environmental programs has led to the elimination of painted cases in this product line. Removal of the paint has minimal affect on the RMS current ratings; see the standard ratings charts for proper application.

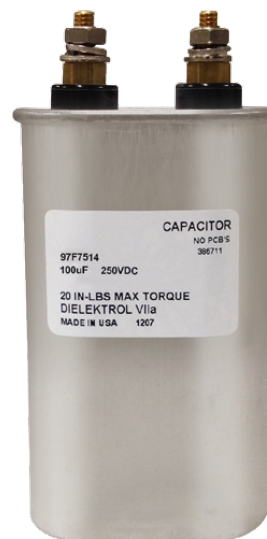

Specifications

Available Capacitance Range	1 to 50 uF
Capacitance Tolerance	± 10 %
Capacitance Variation with Temperature	± 3% from -55°C to +85°C
Rated Voltage	See Ratings Tables. Rating is the Maximum Peak voltage permissible in either polarity.
Rated Current	See Ratings Tables. The value given is for derating purposes only. Refer to the Application Note on Page 12 to determine the required derating. In no circumstances should the RMS Current rating of the terminals be exceeded.
Operating Temperature	-40°C to +75°C
Storage Temperature	-55°C to +90°C
Operating Life	40,000 hours with 95% survival with proper derating
Dissipation Factor	0.02% maximum
Case Material/Finish	Oval Case & Cover: Unpainted Aluminum Rectangular Case & Cover: Unpainted Steel
Terminations/Hardware	1/4 - 20 screw thread studs (60 A RMS maximum) 3/8 - 16 screw thread studs (100 A RMS maximum) Case Styles C* and D* have 100-A terminals. Nut and washer hardware is supplied in bag
Dielectric Fluid	Dielektrol VII
Internal Protection	These capacitors do not contain an internal protection mechanism. The user is responsible for ensuring that the capacitors are correctly applied for safe use.

* Denotes 3/8-16; 100 Amp Terminal

Standard Ratings

CAPACITANCE (UF)	CATALOG #	CASE STYLE	HEIGHT C (IN)	CURRENT (A)
600 Volts Peak				
2	A97F8670S	A	2.38	38
5	A97F8671S	A	4.50	86
10	A97F8672S	C	4.25	136
20	A97F8673S	D	5.25	235
30	A97F8674S	D	7.25	339
40	A97F8675SC	G	5.00	414
50	A97F8676SC	G	6.00	640
800 Volts Peak				
1	A97F8677S	A	2.62	28
2	A97F8678S	A	3.50	47
5	A97F8679S	C	3.88	92
10	A97F8680S	C	5.75	158
20	A97F8681SC	G	5.00	276
25	A97F8682SC	G	6.00	340
30	A97F8683SC	G	6.00	394

All units are unpainted case & cover

CASE STYLE	a	b	d	f
A	2.16	1.31	0.81	1.18
C	2.91	1.91	1.38	1.12
D	3.66	1.97	1.38	1.12
C*	2.91	1.91	1.25	0.91
D*	3.66	1.97	1.25	0.91

* Denotes 3/8-16; 100 Amp Terminal

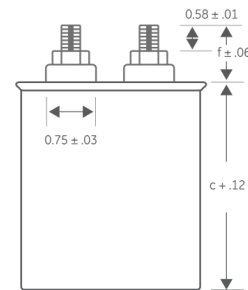
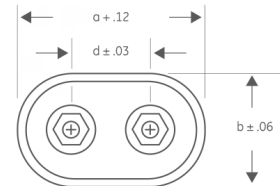

Case Styles A, C and D

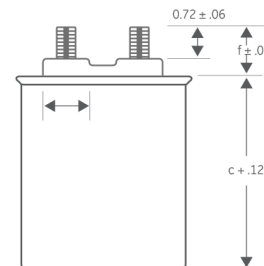
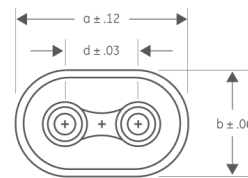

Case Styles C* and D*

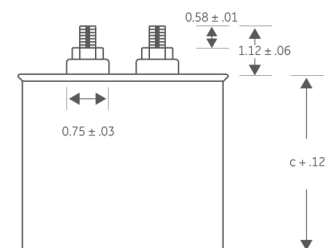
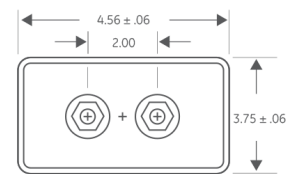

Case Styles G

Standard Ratings

CAPACITANCE (UF)	CATALOG #	CASE STYLE	HEIGHT C (IN)	CURRENT (A)
1000 Volts Peak				
2	A97F8614S	A	4.75	55
3	A97F8615S	C	3.88	71
5	A97F8616S	C	4.75	102
5	A97F8617S	C*	5.25	107
10	A97F8618S	D	6.25	182
10	A97F8619S	D*	6.75	189
50	A97F8676SC	G	6.00	640
1500 Volts Peak				
1	A97F8620S	A	3.88	35
2	A97F8621S	C	3.88	58
3	A97F8622S	C	4.50	76
5	A97F8623S	C	6.25	116
5	A97F8624S	C*	6.75	121
10	A97F8625SC	G	5.00	207

All units are unpainted case & cover

CASE STYLE	a	b	d	f
A	2.16	1.31	0.81	1.18
C	2.91	1.91	1.38	1.12
D	3.66	1.97	1.38	1.12
C*	2.91	1.91	1.25	0.91
D*	3.66	1.97	1.25	0.91

* Denotes 3/8-16; 100 Amp Terminal

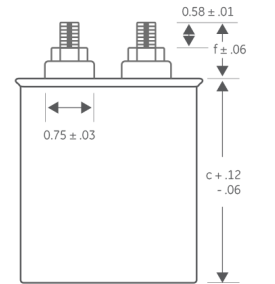
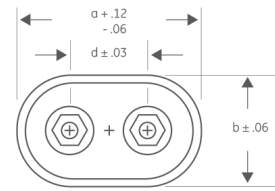

Case Styles A, C and D

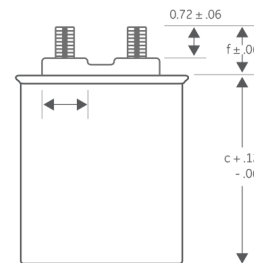
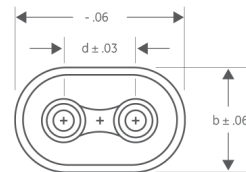

Case Styles C* and D*

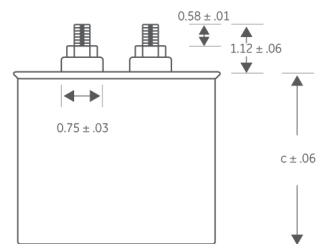
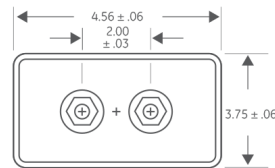

Case Styles G

97F7500 Series SCR Commutation Capacitors

250 Volts Peak

The 97F7500 Series is a special purpose line designed for applications where a large micro-farad value at low voltage is required in a small size. The dielectric system is self clearing metallized polypropylene. Typical applications are in SCR chopper circuits and low-voltage ac filters. Refer to Application Note on page 12 for assistance in the correct application of these capacitors.

Please note that previous offering of these capacitors was with painted cases, to improve heat dissipation. The units will no longer be painted as part of GE Vernova's commitment to environmental programs. Please note the change in RMS current ratings from previous catalogs.



Specifications

Available Capacitance Range:	25 to 200 uF
Capacitance Tolerance:	± 10 %
Capacitance Variation with Temperature:	± 3% from -20°C to +80°C
Rated Voltage:	250 V Peak. The rating is the Maximum Peak voltage permissible in either polarity.
Rated Current:	See Ratings Tables. The value given is for de-rating purposes only. Refer to the Application Note on Page 12 to determine the required de-rating. In no circumstances should the RMS current rating of the terminals be exceeded.
Operating Temperature:	-40°C to +70°C
Storage Temperature:	-55°C to +90°C
Operating Life:	40,000 hours with 95% survival with proper de-rating
Dissipation Factor:	0.3% maximum @ 1 kHz 0.1% maximum @ 120 Hz
Case Material/Finish:	Oval Case & Cover: Aluminum Unpainted Case & Cover
Terminations/Hardware:	1/4 - 20 screw thread studs (60 A RMS maximum)
Dielectric Fluid:	Epoxidized Soybean Oil

Standard Ratings

CAPACITANCE (UF)	CATALOG #	CASE STYLE	HEIGHT C (IN)	CURRENT (A)**
250 Volts Peak				
50	97F7520S	C	3.12	27
100	97F7514S	D	3.50	45
125	97F7513S	D	4.25	55
150	97F7512S	D	4.75	64

**NOTE ALL RMS CURRENT RATINGS ARE FOR UNPAINTED UNITS

CASE STYLE	A	B	D	F
C	2.91	1.91	1.38	1.12
D	3.66	1.97	1.38	1.12

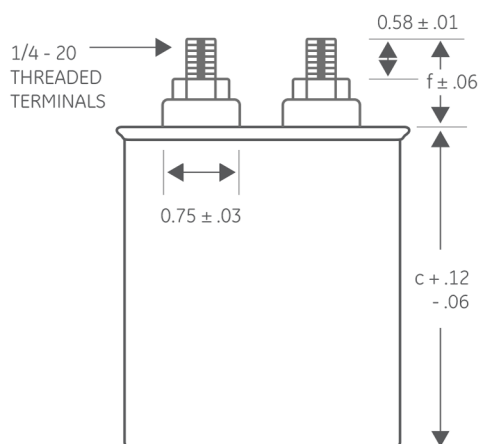
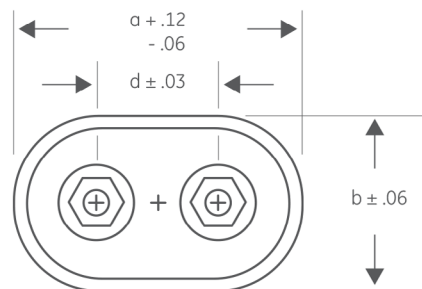

Snubber Capacitors

A28F5000S Series Snubber Capacitors

1000 and 2000 Volts Peak/Max DC

The A28F5000S series of Snubber Capacitors are designed for use in power semiconductor circuits to protect the semiconductor by limiting the rate of voltage rise. The dielectric system is polypropylene with foil electrodes. The RMS currents encountered in these circuits are usually low; however, the peak currents are very high. Refer to the Application Data correct application of these capacitors.



Specifications

Available Capacitance Range:	0.05 to 2 uF
Capacitance Tolerance:	± 10 %
Capacitance Variation with Temperature:	± 3% from -30°C to +80°C
Rated Voltage:	See Ratings Table. The rating is the Maximum Peak voltage permissible in either polarity.
Rated Current:	See Ratings Tables. The value given is for de-rating purposes only. Refer to the Application Note on Page 12 to determine the required de-rating. In no circumstances should the 10 Amp RMS Current rating of the eyelet terminals be exceeded. For 1/4-20 threaded terminals, full current less any de-rating may be applied.
Operating Temperature:	-40°C to +70°C
Storage Temperature:	-55°C to +90°C
Operating Life:	40,000 hours with 95% survival with proper de-rating
Dissipation Factor:	0.02% maximum
Case Material/Finish:	Aluminum Case with Steel Cover for eyelet terminal designs; Aluminum Case with Aluminum Cover for *Threaded terminals.
Terminations:	0.125-in. Solder Eyelets (10 Amp RMS maximum) & 1/4-20 screw thread studs (60 A RMS maximum) For threaded terminal designs, nut and washer hardware is supplied in bag
Dielectric Fluid:	Dielektrol VII
Internal Protection:	Internal Pressure Sensitive Interrupter for eyelet designs. Threaded terminal designs do not contain an internal protection mechanism. The user is responsible for ensuring that the capacitors are correctly applied for safe use.

Standard Ratings*

CAPACITANCE (UF)	CATALOG #	CASE STYLE	HEIGHT C (IN)	CURRENT (A)
1000 Volts Peak/Max DC				
0.5	A28F5502S	A	2.12	5
1.0	A28F5503S	A	2.12	7
2.0	A28F5504S	A	2.88	11
2000 Volts Peak/Max DC				
0.05	A28F5600X	A	2.12	2
0.10	A28F5601X	A	2.12	3
0.10	A28F5615X	A*	2.12	3
0.25	A28F5602X	A	2.12	4
0.25	A28F5605X	A*	2.12	4
0.50	A28F5603X	A	2.88	7
0.50	A28F5606X	A*	2.88	7
1.0	A28F5604X	A	4.50	12
1.0	A28F5607X	A*	4.50	12
2.0	A28F5688X	C	4.25	17
2.0	A28F5608X	C*	4.25	17

* Denotes 1/4-20 threaded terminal styles

Note: A28F5608S has a terminal to terminal Dimension of 1.38" not .81"

CASE STYLE	a	b
A	2.16	1.31
C	2.91	1.91

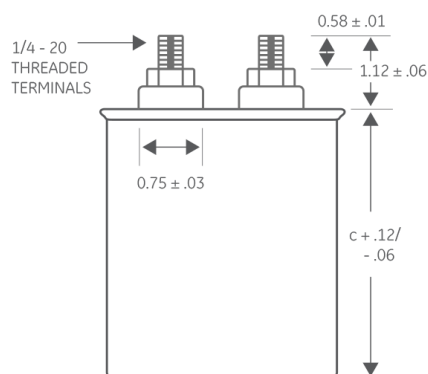
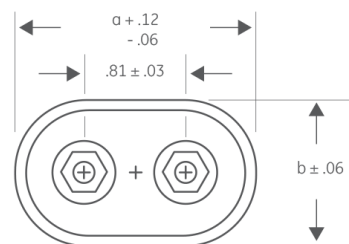
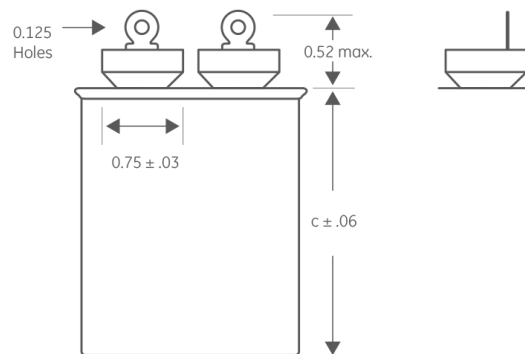
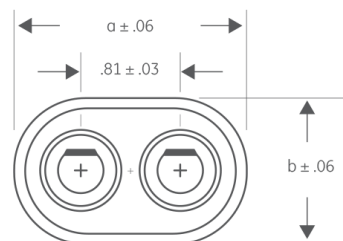

Application Data

Application Data for SCR and Snubber Capacitors

This Application Note is designed to allow users to select the correct capacitor for two common conditions encountered in power electronic circuits:

- Sinusoidal waveform
- Squarewave

For applications that do not fit into either of these categories, please contact your GE Vernova sales representative for assistance.

To select the correct capacitor proceed as follows:

1. Determine the following:
 - (1) Microfarad value required
 - (2) Peak voltage
 - (3) RMS current
 - (4) Current pulsewidth
 - (5) Capacitor ambient temperature
2. Select a capacitor with the correct capacitance and a peak voltage equal to or great than the application voltage.
3. Apply the correction factors on the opposite page for Current Pulsewidth and Ambient Temperature to the 55°C RMS Current Rating of the selected capacitor.

If the “corrected” RMS current value is equal to or greater than the RMS current of the application, the capacitor is suitable. If not, a capacitor with a higher current rating must be selected. This can be done by choosing a higher voltage capacitor. Note that the All-FilmA 97F8600 series has the highest current ratings.

Note: In no case should the actual RMS current exceed the limit of the capacitor terminals.

Example No. 1

Capacitance:	10mF
Voltage:	200 Vac RMS 3 kHz Sinewave
Ambient Temperature:	65°C
Peak Voltage	=200 x √2 =283 Volts
RMS Current	= 2p x 3000 x 10 x 10 – 6 x 200 = 37.7 A
Current Pulsewidth	= 166 us

The A97F8672 has a current rating of 136 A. Applying the correction factors for a 166 ms pulsewidth and a 65°C ambient:

$$\begin{aligned} \text{RMS current rating} &= 136 \times 0.56 \times 0.75 \\ &= 57.1 \text{ A} \end{aligned}$$

This capacitor is satisfactory.
Note the terminal limit of 60 amps.

Example No. 2

Capacitance:	5 uF
Voltage:	60 Vac RMS 16.6 kHz Sinewave
Ambient Temperature:	65°C
Peak Voltage	= 60√2 =85 Volts
RMS Current	= 2p x 16,600 x 5 x 10-6 x 60 = 31.3 A
Current Pulsewidth	= 30 us

The A97F8671 is rated 86 amps which becomes 80.6A with the correction factors. This is more than adequate. Again, note the 60-A terminal limitation.

Example No. 3

Capacitance:	20 uF
Voltage:	600 Vpeak unidirectional Squarewave
Frequency:	200 Hz
Rise Time:	60 us
Fall Time:	60 us
Ambient Temperature:	65°C
Peak Voltage	= 600V

$$1 \text{ peak} = \frac{CDV}{0.64t} = \frac{20 \times 10^{-6} \times 600}{0.64 \times 60 \times 10^{-6}} = 313 \text{ A}$$

$$1 \text{ rms} = 313 \sqrt{60 \times 10^{-6} \times 200} = 32.4 \text{ A}$$

Current Pulsewidth = 60 ms

The A97F8673 has a peak voltage rating of 600 V and a current rating of 235 A. The correction factor for 65°C is 0.75, and for a 60 us pulsewidth it is 0.90. Thus its current rating in this application is 235 x 0.80 x 0.90 = 158.6 A; adequate for the application. Again, note the 60A terminal limitation.

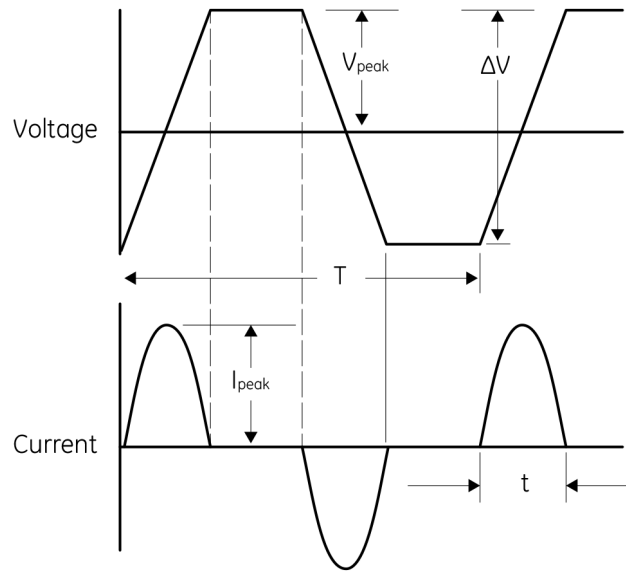
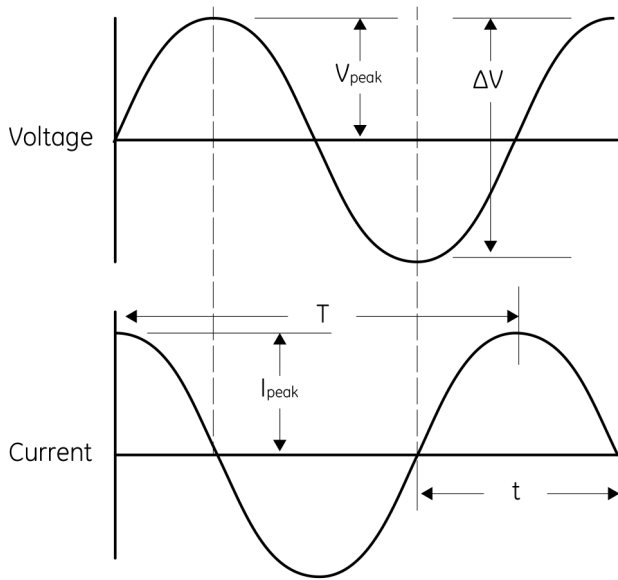

$$1 \text{ rms} = 2p \text{ fC } V_{\text{rms}} = \frac{pC}{t} v \text{ rms}$$

$$1 \text{ peak} = \frac{pC}{t} DV = \frac{CDV}{0.64t}$$

$$V_{\text{peak}} = \sqrt{2} V \text{ rms}$$

$$1 \text{ rms} = \sqrt{2} [1 \text{ peak} \sqrt{ft/2}]^2$$

CORRECTION FACTOR FOR CURRENT PULSEWIDTH

RMS CURRENT CORRECTION FACTOR

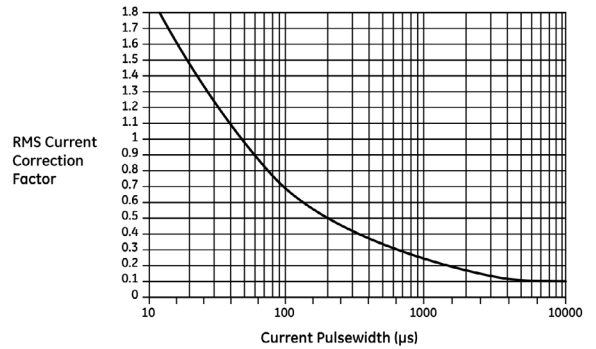

CORRECTION FACTOR FOR AMBIENT PULSEWIDTH

RMS CURRENT CORRECTION FACTOR

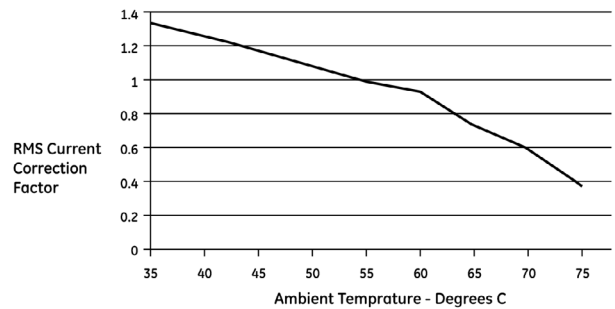

General Purpose DC Capacitors

General Purpose DC Capacitors

1500 and 2500 Volts Peak

This line of General Purpose DC Capacitors is made with film dielectric technology for 1500V and 2500V ratings. These capacitors are typically used in DC filters at voltages above those served by electrolytic type construction.



Specifications

Available Capacitance Range:	0.1 to 50 uF	
Capacitance Tolerance:	26F Series: ± 10 %	
Capacitance Variation with Temperature:	± 5% from -40°C to +70°C	
Rated Voltage:	See Ratings Table. The rating is the Maximum Peak dc voltage.	
Ripple Voltage:	The RMS ripple voltage should not exceed the following percentages of the rated voltage for these frequencies:	
	Frequency	% of Rated Voltage
	60 Hz	30
	120 Hz	20
	400 Hz	14
	1,000 Hz	8
	10,000 Hz	1
Operating Temperature:	-	-30°C to +70°C
Storage Temperature:	-	-55°C to +90°C
Operating Life:	60,000 hours with 94% survival with proper derating	
Dissipation Factor:	0.02% maximum	
Case Material/Finish:	Aluminum Case (NO PAINT)	
Terminations:	(2) 0.25" x 0.031 inch quick connect blades, and one fork blade per terminal	
Dielectric Fluid:	Dielektrol VII	
Internal Protection:	Pressure Sensitive Interrupter	

Standard Ratings*

CAPACITANCE (UF)	CATALOG #	CASE STYLE	HEIGHT C (IN)
1500 Volts Peak			
1	A26F7500S	A	2.12
2	A26F7501S	A	3.12
4	A26F7502S	C	3.12
5	A26F7503S	C	3.88
6	A26F7504S	C	4.25
8	A26F7505S	C	5.25
10	A26F7506S	D	5.25
2500 Volts Peak			
0.1	A26F7515S	A	2.12
0.25	A26F7516S	A	2.12
0.5	A26F7517S	A	2.12
1.0	A26F7518S	A	3.12
2.0	A26F7519S	A	4.25
4.0	A26F7520S	C	4.25

CASE STYLE	a	b
A	2.16	1.31
B	2.69	1.56
C	2.91	1.91
D	3.66	1.97

* Linear insulation withstand for comparison based on sum of units

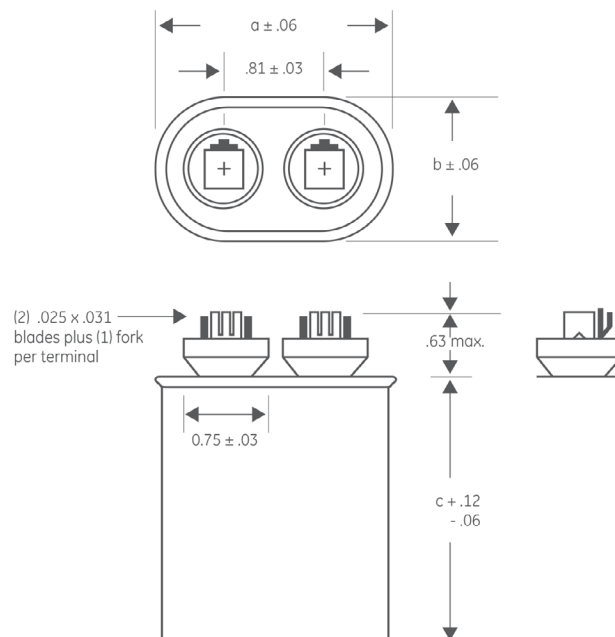

Hardware and Accessories

Mounting Hardware

FOOTED BRACKETS FOR OVAL CASE STYLES (2 per Capacitor)

For the proper bracket, match the capacitor case_brackets height to the case height shown next to the bracket part

CASE HEIGHT	BRACKET PART NUMBER
2.12	302C920000210
2.38	302C920000208
2.62	302C920000200
2.88	302C920000113
3.12	302C920000179
3.50	302C920000119
3.88	302C920000115
4.25	302C920000122
4.50	302C920000211
4.75	302C920000116
5.25	302C920000153
5.50	302C920000233
5.75	302C920000209
6.25	302C920000152
6.75	302C920000213
7.25	302C920000214

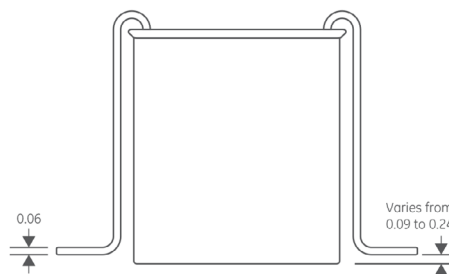
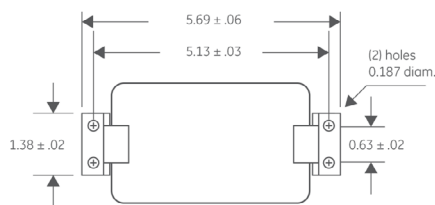
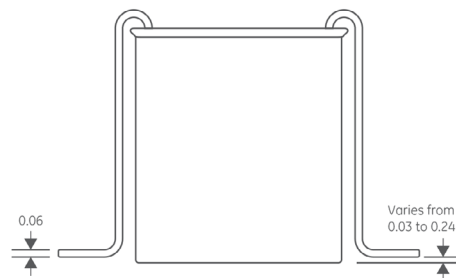
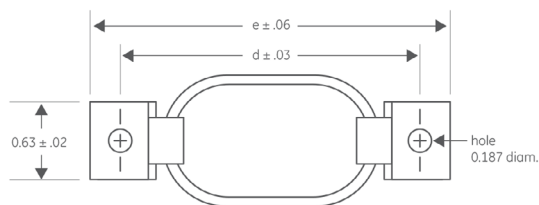

FOOTED BRACKETS FOR RECTANGULAR CASE STYLE G (2 per Capacitor)

For the proper bracket, match the capacitor case_brackets height to the case height shown next to the bracket part

CASE HEIGHT	BRACKET PART NUMBER
5.18	302C920000189
6.25	302C920000190
7.25	302C920000207
8.00	302C920000194
9.00	302C920000196

CASE STYLE	d	e
**A	2.56	3.00
B	3.13	3.56
C	3.38	3.81
D	4.13	4.56

** Cannot be used on "A" base size units with threaded terminals (Aluminum covers).

**UNIVERSAL WRAPAROUND BRACKETS
FOR OVAL CASE STYLES**

CASE STYLE	Bracket Part Number	d	e
A	128A2244AC021	2.69	3.13
B	128A2244AC025	3.27	3.70
C	128A2244AC022	3.44	3.88
D	128A2244AC023	4.19	4.63

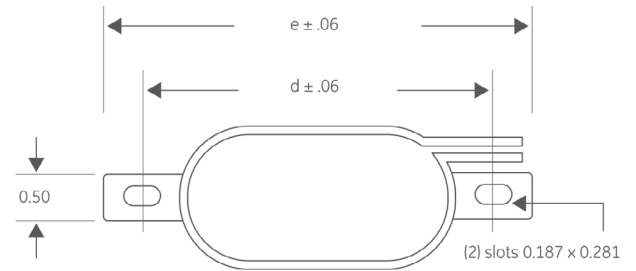

**WRAPAROUND BRACKETS FOR OVAL CASE STYLES
FOR OVAL CASE STYLES**

CASE STYLE	Bracket Part Number	d	e	w	t
A	9827065000021	2.56	2.94	0.50	0.02
B	9827065000031	3.06	3.50	0.63	0.02
C	614A301000061	3.31	3.81	0.75	0.03
D	614A301000051	4.06	4.56	0.75	0.03

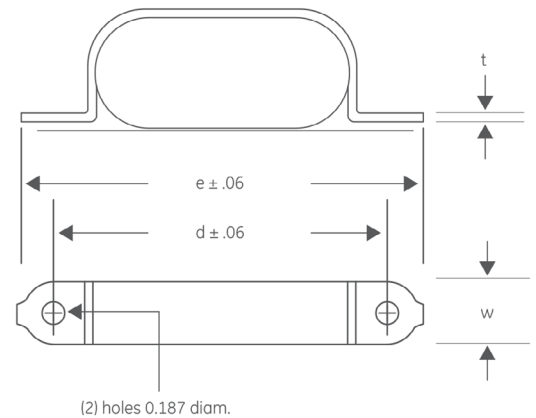
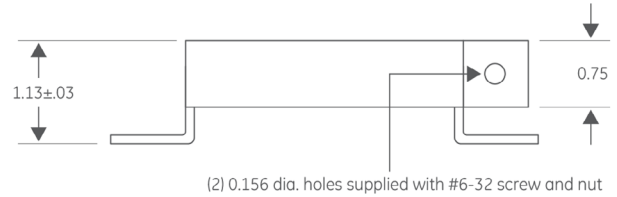

For more information, visit governova.com/grid-solutions

GE Vernova reserves the right to make changes to specifications of products described at any time without notice and without obligation to notify any person of such changes.
© 2025 GE Vernova and/or its affiliates. All rights reserved. GE and the GE Monogram are trademarks of General Electric Company used under trademark license.