

TRANQUELL™ SURGE ARRESTORS

Product Selection & Application Guide

Polymer/Porcelain Station & Intermediate Class IEEE®/ANSI® CS62.11

Surge Protection

The performance and reliability of today's electric power system can be enhanced with the unique characteristics of GE Vernova's TRANQUELL™ arrester products. Since introducing the world's first metal oxide arrester in 1976, offering new concepts in surge arrester design and application, Grid Solutions at GE Vernova has developed and applied metal oxide technology for a variety of traditional and special applications. We offers one of the most complete lines of surge arrester products in the world today; from distribution class to EHV arresters up to 612 kV rating as well as high energy varistors for series capacitor applications.

Product and power systems engineers work closely to enhance product performance on the system. Grid Solutions is one of the world's leading suppliers of metal oxide arresters and specialty varistors.

Station arresters are designed and manufactured in accordance with the latest revision of ANSI/IEEE C62.11. Our TRANQUELL™ polymer and porcelain arresters are designed to meet the most demanding service conditions.



Product Description

TRANQUELL™ arresters provide exceptional overvoltage protection of major power system equipment. Under normal system conditions, the arrester appears as a high impedance path. When a surge reaches the arrester, the arrester changes to a low impedance path and conducts only the current necessary to limit the overvoltage. As a result, TRANQUELL™ arresters absorb minimum energy to protect equipment insulation.



Arrestor Construction

Metal Oxide Disks

The core operating component of a modern lightning arrester is the metal oxide varistor (MOV) element. As one of the world's leaders in MOV formulation, and their use in a gapless construction design, all classes of Grid Solutions' arresters offer the same quality MOV.

Classes of ANSI/IEEE C62.11 Arresters

Our TRANQUELL™ arresters are offered in all classes:

- Station Class
- Porcelain Station Class
- Polymer Intermediate Class
- Polymer Distribution Class
- Polymer Riser Pole
- Polymer

Porcelain Surge Arresters

TRANQUELL™ porcelain surge arresters have been the industry standard for decades. Porcelain models cover voltage ratings from 3 kV to 420 kV. Our TRANQUELL™ porcelain extra high-voltage (EHV) arresters cover ratings above 420 kV.

With unrivaled mechanical strength, and an altitude rating up to 12,000 feet ASL (3,600 m ASL) Grid Solutions' TRANQUELL™ porcelain models fill the most demanding applications. Tested in accordance with IEEE 693, most models meet the high seismic performance level.

Porcelain EHV Arrester

Our TRANQUELL™ EHV arresters incorporate a heat transfer system utilizing silicone-rubber material wedged between the metal oxide disk and internal porcelain wall. Heat generated in the valve element from steady state, temporary, or transient conditions is transferred through the silicone-rubber material to the porcelain housing and then dissipated to the outside environment.

Polymer Surge Arresters

Our TRANQUELL™ polymer surge arresters are constructed utilizing a rugged field-proven silicone alloy EPDM housing. Polymer models cover voltage ratings from 3 kV to 228 kV. GE Vernova TRANQUELL™ polymer arresters offer exceptional electrical characteristics such as low protective levels, high energy handling capability, and improved temporary over voltage (TOV) capability. The electrical performance of the polymer arresters is enhanced by its ability to easily transfer heat from the metal oxide elements to the outside environment. These light-weight non-shattering designs fit both 8.75" and 10" mounting patterns.

Arresters Testing ANSI/IEEE C62.11

Grid Solutions' TRANQUELL™ arresters comply with the design tests outlined in ANSI/IEEE C62.11. At a minimum, the IEEE C62.11 clauses below are tested and met:

- Insulation Withstand
- Discharge Voltage
- Disc Accelerated Aging
- Contamination
- RIV
- High Current, Short Duration
- Transmission Line Discharge
- Duty Cycle
- Temporary Overvoltage
- Short Circuit
- Ultimate Mechanical Strength-Static
- Partial Discharge

In addition, factory tests are performed on each metal oxide disk. Long-term stability tests are conducted on each and improved. Every disk is subjected to an impulse current of 10kA 8/20ms to measure its discharge voltage or nominal protective level. A disk strength test series, consisting of multiple transmission-line discharges, is performed to make certain that the disk has full energy capabilities.

Selection of Arrester Rating

The objective of the application of an arrester is to select the lowest rated surge arrester that will have a satisfactory service life on the power system while providing adequate protection of equipment insulation. An arrester of the minimum practical rating is generally preferred because it provides the greatest margin of protection for the insulation. The use of a higher rating increases the capability of the arrester to survive on the power system, but reduces the margin of protection it provides for a specific insulation level. Thus, arrester selection must strike a balance between arrester survival and equipment protection.

Table 1 lists arrester ratings that would normally be applied on systems of various line-to-line voltages. The rating of the arrester is defined as the rms voltage at which the arrester passes the duty-cycle test as defined by the referenced standard. To decide which rating is most appropriate for a particular application,

Table 1A — Typical Arrester Ratings for System Voltages

| ARRESTER RATING (kV) rms | MCOV ¹ CAPABILITY (L-N) (kV) rms | | NORMALLY USED ON SYSTEM VOLTAGE CLASS (L-L) | |
|--------------------------|---|---------|---|---------------------------------|
| | Porcelain | Polymer | HIGH IMPEDANCE ² GROUNDED, UNGROUNDED (DELTA) OR TEMPORARILY UNGROUNDED CIRCUITS | SOLIDLY GROUNDED NEUTRAL kV rms |
| | | | | |
| 3 | 2.55 | 2.55 | 2.4 | 4.16 |
| 6 | 5.1 | 5.1 | 4.8 | 4.8 |
| 9 | 7.65 | 7.65 | 6.9 | 12.47 |
| 10 | 8.4 | 8.4 | 8.32 | 13.8 |
| 12 | 10.2 | 10.2 | 12 | - |
| 15 | 12.7 | 12.7 | 13.8 ² | 20.78 |
| 18 | 15.3 | 15.3 | 13.8 | 24.94 |
| 21 | 17 | 17 | - | 24.94 |
| 24 | 19.5 | 19.5 | 23 ² | - |
| 27 | 22 | 22 | 23 | 34.5 |
| 30 | 24.4 | 24.4 | 24.94 | 34.5 |
| 36 | 29 | 19 | 34.5 ² | - |
| 39 | 31.5 | 31.5 | 34.5 ² | - |
| 45 | 36.5 | 36.5 | 34.5 | - |
| 48 | 39 | 39 | 46 ² | - |
| 54 | 42 | 42 | - | 69 |
| 60 | 48 | 48 | 46 | 69 |
| 66 | 53 | 53 | 46 | - |
| 72 | 57 | 57 | 69 ² | - |
| 90 | 74 | 70 | 69 | 115 |
| 96 | 76 | 76 | - | 115 |
| 108 | 84 | 84 | - | 138 |
| 108 | 88 | 88 | - | 138 |
| 120 | 98 | 98 | 115 ² | 161 |
| 132 | 106 | 106 | - | 161 |

¹ TRANQUELL™ Arresters are designed to be operated at voltages equal to or less than their continuous capability as stated in MCOV column 2.

consideration must be given to the following system stresses to which the arrester will be exposed:

- Continuous system voltage
- Temporary overvoltages
- Switching surges (frequently a consideration in systems of 345 kV and above, and for capacitor banks and cable applications)
- Lightning surges

The arrester selected must have sufficient capability to meet the anticipated service requirements in all categories.

For effectively grounded neutral systems, our TRANQUELL™ arresters with MCOV equal to the maximum line to neutral kV is the normal application. As an example, a 230 kV system usually has a maximum line-to-line continuous voltage of 242 kV line-to-ground voltage.

Table 1B — Typical Arrester Ratings for System Voltages

| ARRESTER RATING (kV) rms | MCOV CAPABILITY (L-N) (kV) rms | | NORMALLY USED ON SYSTEM VOLTAGE CLASS (L-L) | |
|--------------------------|--------------------------------|---------|--|-----------------------------------|
| | Porcelain | Polymer | HIGH IMPEDANCE GROUNDED, UNGROUNDED (DELTA) OR TEMPORARILY UNGROUNDED CIRCUITS | SOLIDLY GROUNDED NEUTRAL (kV) rms |
| | | | | |
| 144 | 115 | 115 | 138 ² | 161 |
| 168 | 131 | 131 | 138 | - |
| 172 | 140 | 140 | 161 ² | 230 |
| 180 | 144 | 144 | - | 230 |
| 192 | 152 | 152 | 161 | 230 |
| 228 | 180 | 180 | - | - |
| 240 | 194 | 194 | - | - |
| 258 | 209 | | FOR NOMINAL 345 kV SYSTEMS | |
| 264 | 212 | | FOR NOMINAL 345 kV SYSTEMS | |
| 276 | 220 | | FOR NOMINAL 345 kV SYSTEMS | |
| 288 | 234 | | FOR NOMINAL 345 kV SYSTEMS | |
| 294 | 237 | | FOR NOMINAL 345 kV SYSTEMS | |
| 300 | 243 | | FOR NOMINAL 345 kV SYSTEMS | |
| 312 | 245 | | FOR NOMINAL 400 kV SYSTEMS | |
| 336 | 264 | | FOR NOMINAL 400 kV SYSTEMS | |
| 360 | 288 | | FOR NOMINAL 400 kV SYSTEMS | |
| 396 | 318 | | FOR NOMINAL 500 kV SYSTEMS | |
| 420 | 335 | | FOR NOMINAL 500 kV SYSTEMS | |
| 396 | 318 | | FOR NOMINAL 500 kV SYSTEMS | |
| 420 | 335 | | FOR NOMINAL 500 kV SYSTEMS | |
| 444 | 353 | | FOR NOMINAL 500 kV SYSTEMS | |
| 588 | 470 | | FOR NOMINAL 765 kV SYSTEMS | |
| 612 | 485 | | FOR NOMINAL 765 kV SYSTEMS | |

² Application of specific ratings is permissible for ungrounded or resistance grounded systems where a single phase ground may be tolerated for a substantial period of time not to exceed the arrester's overvoltage capability.

Voltage arresters in service are continually exposed to system operating voltage. For each arrester rating there is a recommended limit to the magnitude of voltage which may be continuously applied. This has been termed the Maximum Continuous Operating Voltage (MCOV) of the arrester. The MCOV of each TRANQUELL™ arrester is contained in Table 2. These values meet or exceed those values contained in the referenced standard. The arrester rating must be selected such that the maximum continuous power system voltage applied to the arrester is less than, or equal to, the arrester's continuous voltage capability. Attention must be given to both the circuit connection (single phase, wye or delta)

and the arrester connection (line-to-ground, line-to-line). In most cases, the arrester is connected line-to-ground and therefore must withstand line-to-ground system operating voltage. If an arrester is to be connected line-to-line, phase-to-phase voltage must be considered. In addition, attention should be given to an arrester application on the delta tertiary winding of a transformer where one corner of the delta is permanently grounded. In such circuits, the normal voltage continuously applied to the arrester will be the full phase-to-phase voltage even though the arresters are connected line-to-ground.

Table 2a — Polymer Station Class Arrester Characteristics

| RATED VOLTAGE (kV) | MAXIMUM CONTINUOUS OPERATING VOLTAGE (MCOV) (kV) rms | MAXIMUM 0.5µs DISCHARGE VOLTAGE kV ⁽¹⁾ | MAXIMUM SWITCHING SURGE PROTECTIVE LEVEL kV ⁽²⁾ | MAXIMUM DISCHARGE VOLTAGE USING 8/20 CURRENT WAVE-kV | | | | | |
|--------------------|--|---|--|--|-------|-------|-------|-------|-------|
| | | | | 1.5 kA | 3 kA | 5 kA | 10 kA | 20 kA | 40 kA |
| 3 | 2.6 | 8.4 | 6.0 | 6.4 | 6.7 | 7.1 | 7.6 | 8.4 | 9.6 |
| 6 | 5.1 | 16.7 | 11.9 | 12.8 | 13.5 | 14.1 | 15.2 | 16.8 | 19.1 |
| 9 | 7.7 | 25.0 | 17.8 | 19.2 | 20.2 | 21.1 | 22.7 | 25.1 | 28.3 |
| 10 | 8.4 | 27.8 | 19.8 | 21.4 | 22.5 | 23.5 | 25.3 | 28.0 | 31.8 |
| 12 | 10.2 | 33.3 | 23.7 | 25.6 | 26.9 | 28.1 | 30.3 | 33.5 | 38.1 |
| 15 | 12.7 | 41.7 | 29.7 | 32.0 | 33.7 | 35.2 | 37.9 | 42.0 | 47.6 |
| 18 | 15.3 | 50.1 | 35.6 | 38.4 | 40.4 | 42.3 | 45.5 | 50.4 | 57.2 |
| 21 | 17.0 | 56.3 | 40.1 | 43.2 | 45.5 | 47.6 | 51.2 | 56.7 | 64.4 |
| 24 | 19.5 | 63.9 | 45.5 | 49.1 | 51.6 | 54.0 | 58.1 | 64.3 | 73.0 |
| 27 | 22.0 | 72.9 | 51.9 | 56.0 | 58.9 | 61.6 | 66.3 | 73.4 | 83.3 |
| 30 | 24.4 | 80.4 | 57.2 | 61.7 | 64.9 | 67.9 | 73.1 | 80.9 | 91.9 |
| 36 | 29.0 | 95.9 | 68.3 | 73.6 | 77.4 | 81.0 | 87.2 | 96.5 | 109.6 |
| 39 | 31.5 | 104.2 | 74.2 | 80.0 | 84.1 | 88.0 | 94.7 | 104.8 | 119.0 |
| 45 | 36.5 | 120.9 | 86.1 | 92.8 | 97.6 | 102.1 | 109.9 | 121.7 | 138.1 |
| 48 | 39.0 | 128.7 | 91.6 | 98.8.0 | 103.9 | 108.7 | 117.0 | 129.5 | 147.1 |
| 54 | 42.0 | 144.4 | 102.8 | 110.9 | 116.6 | 122.0 | 131.3 | 145.3 | 165.0 |
| 60 | 48.0 | 163.5 | 116.4 | 125.5 | 132.0 | 138.0 | 148.6 | 164.5 | 186.8 |
| 72 | 57.0 | 191.8 | 136.6 | 147.3 | 154.9 | 162.0 | 174.4 | 193.1 | 219.2 |
| 90 | 70.0 | 241.8 | 172.1 | 185.6 | 195.2 | 204.2 | 219.8 | 243.3 | 276.3 |
| 96 | 76.0 | 257.4 | 183.2 | 197.6 | 207.8 | 217.4 | 234.0 | 259.0 | 294.1 |
| 108 | 84.0 | 288.9 | 205.6 | 221.8 | 233.2 | 244.0 | 262.6 | 290.7 | 330.1 |
| 108 | 88.0 | 288.9 | 205.6 | 221.8 | 233.2 | 244.0 | 262.6 | 290.7 | 330.1 |
| 120 | 98.0 | 326.9 | 241.3 | 251.0 | 263.9 | 276.1 | 297.2 | 329.0 | 373.6 |
| 132 | 106.0 | 352.0 | 252.0 | 270.0 | 284.0 | 298.0 | 317.0 | 353.0 | 404.0 |
| 144 | 115.0 | 386.1 | 285.0 | 296.5 | 311.7 | 326.1 | 351.0 | 388.6 | 441.2 |
| 168 | 131.0 | 445.0 | 330.0 | 343.0 | 363.0 | 380.0 | 409.0 | 446.0 | 503.0 |
| 172 | 140.0 | 455.0 | 338.0 | 351.0 | 372.0 | 389.0 | 419.0 | 457.0 | 516.0 |
| 180 | 144.0 | 476.0 | 354.0 | 367.0 | 389.0 | 407.0 | 438.0 | 478.0 | 539.0 |
| 192 | 152.0 | 508.0 | 377.0 | 391.0 | 415.0 | 434.0 | 467.0 | 509.0 | 575.0 |
| 228 | 180.0 | 604.0 | 448.0 | 465.0 | 493.0 | 516.0 | 556.0 | 607.0 | 684.0 |

¹ Maximum discharge voltage for a 10 kA impulse current wave which produces a voltage wave cresting in 0.5µs. This can be used for coordination where front-of-wave sparkover was formerly used.

² Based on a 500A surge of 45-µs time to crest through 88kV MCOV, and 1,000A surge of 45-µs time to crest for 98kV MCOV and higher ratings.

Table 2B — Porcelain Station Class Arrester Characteristics

| TYPE | RATED VOLTAGE (kV) | MAXIMUM CONTINUOUS OPERATING VOLTAGE (MCOV) (kV) rms | MAXIMUM 0.5µs DISCHARGE VOLTAGE kV ⁽¹⁾ | MAXIMUM SWITCHING SURGE PROTECTIVE LEVEL kV ⁽²⁾ | 1.5 kA | 3k A | 5 kA | 10 kA | 20 kA | 40 kA |
|-----------------|--------------------|--|---|--|--------|------|------|-------|-------|-------|
| 4 Hold NEM=A | 3 | 2.55 | 9.1 | 6.3 | 6.9 | 7.2 | 7.5 | 8 | 9 | 10.3 |
| | 6 | 5.1 | 17.9 | 12.4 | 13.6 | 14.2 | 14.8 | 15.8 | 17.7 | 20.3 |
| | 9 | 7.65 | 26.6 | 18.4 | 20.2 | 21.1 | 22 | 23.5 | 26.4 | 30.2 |
| | 10 | 8.4 | 29.3 | 20.3 | 22.2 | 23.3 | 24.2 | 25.9 | 29.1 | 33.3 |
| | 12 | 10.2 | 35.5 | 24.6 | 26.9 | 28.2 | 29.4 | 31.4 | 35.2 | 40.4 |
| | 15 | 12.7 | 44.2 | 30.6 | 33.5 | 35.1 | 36.6 | 39.1 | 43.9 | 50.3 |
| | 18 | 15.3 | 53.3 | 36.8 | 40.4 | 42.3 | 44.1 | 47.1 | 52.8 | 60.6 |
| | 21 | 17 | 59.1 | 40.9 | 44.8 | 46.9 | 48.9 | 52.3 | 58.7 | 67.2 |
| | 24 | 19.5 | 67.8 | 46.9 | 51.4 | 53.8 | 56.1 | 60 | 67.3 | 77.1 |
| | 27 | 22 | 76.5 | 52.9 | 58 | 60.8 | 63.3 | 67.7 | 75.9 | 87 |
| | 30 | 24.4 | 84.9 | 58.7 | 64.3 | 67.4 | 70.3 | 75.1 | 84.2 | 96.5 |
| | 36 | 29 | 101 | 69.7 | 76.4 | 80 | 83.4 | 89.2 | 100 | 115 |
| | 39 | 31.5 | 110 | 75.8 | 83 | 86.9 | 90.6 | 96.9 | 109 | 125 |
| | 45 | 36.5 | 128 | 88.3 | 96.8 | 102 | 106 | 113 | 127 | 146 |
| | 48 | 39 | 136 | 93.8 | 103 | 108 | 113 | 120 | 135 | 155 |
| | 54 | 42 | 135 | 100 | 107 | 112 | 117 | 125 | 136 | 151 |
| | 60 | 48 | 150 | 111 | 119 | 125 | 130 | 139 | 151 | 168 |
| | 72 | 57 | 178 | 132 | 141 | 148 | 154 | 165 | 179 | 199 |
| | 90 | 70 | 225 | 166 | 178 | 187 | 195 | 208 | 226 | 251 |
| | 90 | 74 | 238 | 176 | 188 | 198 | 206 | 220 | 239 | 265 |
| | 96 | 76 | 238 | 176 | 188 | 198 | 206 | 220 | 239 | 265 |
| | 108 | 84 | 269 | 199 | 213 | 224 | 233 | 249 | 270 | 300 |
| | 108 | 88 | 275 | 203 | 218 | 228 | 238 | 254 | 276 | 306 |
| | 120 | 98 | 306 | 235 | 242 | 254 | 265 | 283 | 307 | 341 |
| | 132 | 106 | 332 | 254 | 263 | 276 | 287 | 307 | 333 | 370 |
| | 144 | 115 | 360 | 276 | 285 | 299 | 312 | 333 | 361 | 402 |
| | 168 | 131 | 416 | 319 | 330 | 346 | 360 | 385 | 418 | 464 |
| | 172 | 140 | 438 | 336 | 347 | 363 | 379 | 405 | 439 | 488 |
| | 180 | 144 | 450 | 345 | 357 | 374 | 390 | 416 | 452 | 502 |
| | 192 | 152 | 476 | 365 | 377 | 395 | 412 | 440 | 477 | 531 |
| | 228 | 180 | 568 | 436 | 450 | 472 | 492 | 526 | 570 | 634 |
| | 258 | 209 | 659 | 526 | 522 | 547 | 570 | 609 | 661 | 735 |
| | 264 | 212 | 662 | 528 | 524 | 550 | 573 | 612 | 664 | 738 |
| | 276 | 220 | 687 | 548 | 544 | 570 | 594 | 635 | 689 | 766 |
| | 288 | 234 | 728 | 581 | 577 | 605 | 630 | 673 | 731 | 812 |
| | 294 | 237 | 743 | 593 | 589 | 617 | 643 | 687 | 746 | 829 |
| 300 | 243 | 759 | 606 | 601 | 630 | 657 | 702 | 762 | 846 | |
| 312 | 245 | 773 | 617 | 612 | 641 | 668 | 714 | 775 | 862 | |
| 336 | 264 | 833 | 665 | 659 | 690 | 719 | 767 | 835 | 929 | |
| 360 | 288 | 933 | 734 | 732 | 771 | 798 | 849 | 945 | 1053 | |
| 396 | 318 | 1139 | 816 | 822 | 861 | 897 | 959 | 1055 | - | |
| 420 | 335 | 1278 | 901 | 900 | 945 | 986 | 1058 | 1164 | - | |
| 444 | 353 | 1351 | 953 | 952 | 999 | 1043 | 1199 | 1231 | - | |
| 588 | 470 | | | | | | | | | |
| 612 | 485 | | | | | | | | | |
| 588 | 470 | | | | | | | | | |
| 612 | 485 | | | | | | | | | |

⁽¹⁾ Maximum discharge voltage for an impulse current wave which produces a voltage wave cresting in 0.5µs. Discharge currents are 10 kA for 2.55 - 245kV MCOV. This can be used for coordination where front-of-wave sparkover formerly was used.

⁽²⁾ Discharged voltages are based on a 500A surge of 45µs time to crest through 88 kV MCOV, and 1,000A surge of 45-µs time to crest through 180 kV MCOV and 2,000A through 245 kV MCOV MAXIMUM 0.5µs.

Temporary Overvoltages

Temporary overvoltages (TOV) can be caused by a number of system events such as line-to-ground faults, circuit backfeeding, load rejection and ferroresonance. The system configuration and operating practices should be reviewed to identify the most probable forms of temporary overvoltages which may occur at the arrester location.

The primary effect of temporary overvoltages on metal oxide arresters is increased current and power dissipation, and a rising arrester temperature. TOV figures on page 7 show the temporary overvoltage capability of GE Vernova's arrester designs. This figure defines the duration and magnitude of temporary overvoltages that may be applied to the arrester before the arrester voltage must be reduced to the arresters' continuous operating voltage capability. These capabilities have been defined independent of system impedance and are therefore valid for voltages applied at the arrester location.

Table 4 - Energy Capability

| ARRESTER RATED VOLTAGE (kV) rms | HOUSING TYPE | ARRESTER TYPE | kJ/kV OF MCOV |
|---------------------------------|--------------|----------------------|---------------|
| 3 - 144 kV | Polymer | Intermediate/Station | 6 |
| 2 - 57 kV | Polymer | Station | 6 |
| 3 - 228 kV | Polymer | Station | 9 |
| 3 - 48 kV | Porcelain | Station | 9 |
| 54 - 312 kV | Porcelain | Station | 9 |

Table 5 — Pressure Relief

| ARRESTER TYPE | ARRESTER SERIES | PRESSURE RELIEF CAPABILITY-SYMMETRICAL rms kA | |
|---|-----------------|---|-----------------------------|
| | | ANSI STANDARD C62.11 MINIMUM | PRODUCT DEMONSTRATED VALUES |
| Porcelain Station-Porcelain top * | 9L11ZGB | None | 10 |
| Porcelain Station-Metal top * | 9L11ZGA | 40-65 | 65 |
| Porcelain Station-Metal top * | 9L11ZTA | 40-65 | 93 |
| Silicone Station-Metal top, rigid core ** | 9L11HMA | 40-65 | 63 |
| Polymer Station-4 hole NEMA or eyebolt ** (compact designs) | 9L11XPN/XPT/XPM | 40-65 | 40 |
| Polymer Intermediate-4 hole NEMA or eyebolt ** | 9L12PPA/PPB | 16.1 | 40 |
| Polymer Intermediate-eyebolt ** | 9L12PPT | 16.1 | 16.1 |

* Rating for initial venting only

** Polymer arrestors will survive multiple venting events

TOV Curves for Porcelain and Polymer Station and Intermediate Class Arrester

TOV Curves for 9L117 Series Station Class Arresters

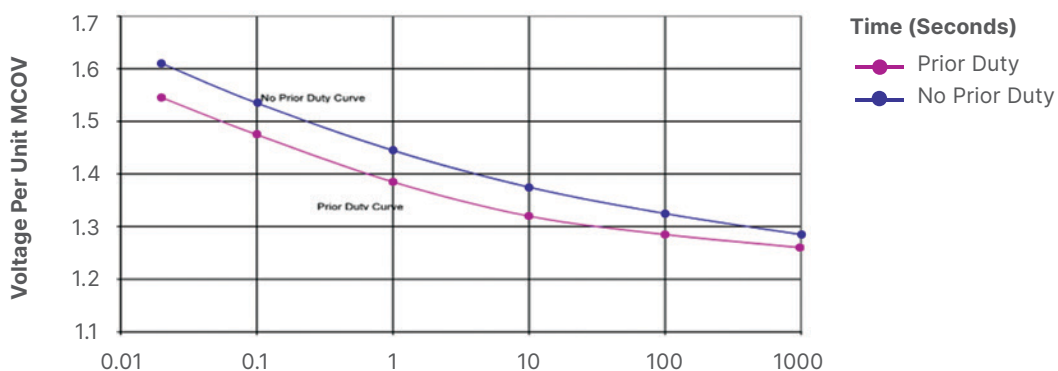

TOV Curves for 9L11XPA/B/E Series Polymer Station Class Arresters

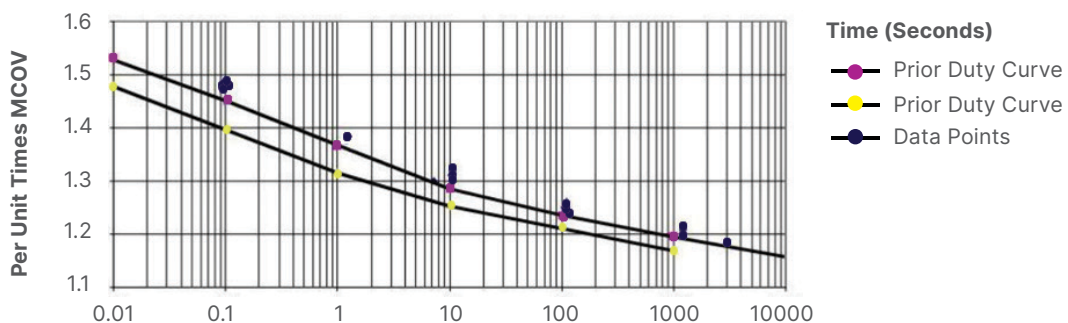

TOV Curves for 9L11XPM/N/T Series 4Hole NEMA & Eyebolt Polymer Station Class Arresters

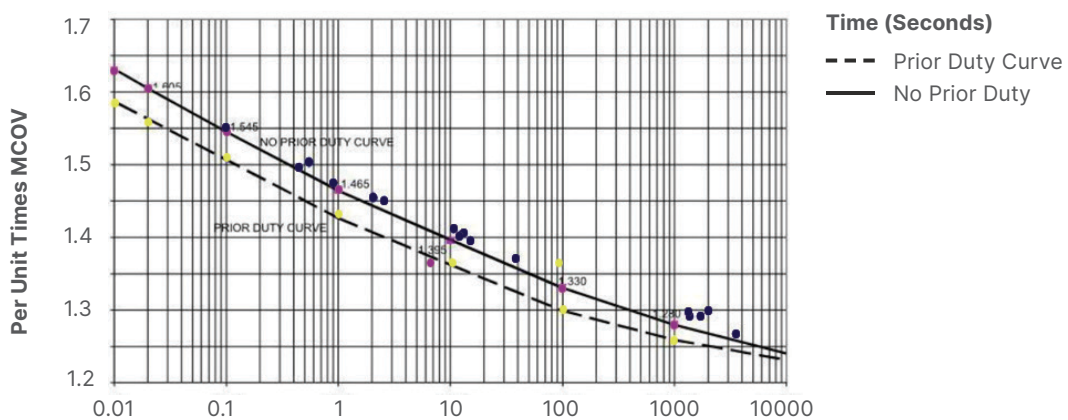

TOV Curves for 9L12 Series Intermediate Class Arresters

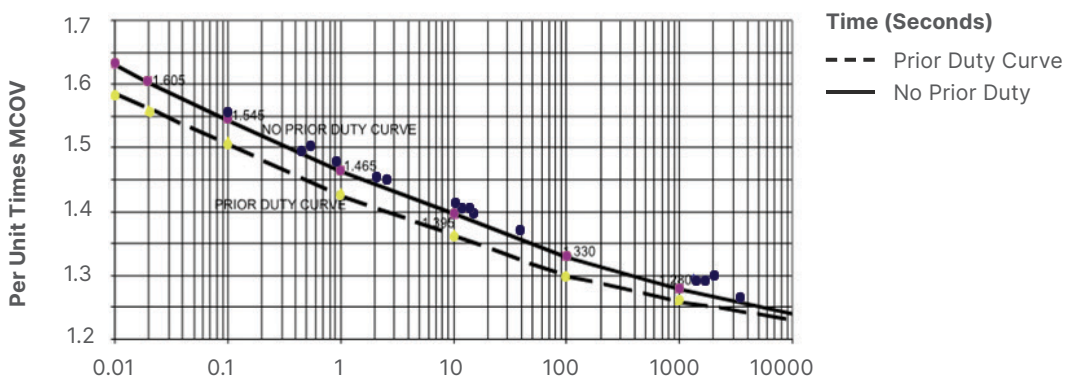

Service Conditions & Other Considerations

Arrester Withstand Capability

Grid Solutions' TRANQUELL™ arresters are built in accordance with contamination tests outlined in ANSI/IEEE C62.11. More demanding tests than those outlined in the ANSI/IEEE C62.11 have shown that TRANQUELL™ arresters have outstanding capability to withstand the effects of very severe external contamination.

In applications where severe contamination is anticipated and extra leakage (creepage) distance is required for other station insulation, the arrester leakage distance should be reviewed. An arrester connected line-to-ground needs to have a leakage distance no greater than that required for the other line-to-ground insulation in the station. Extra leakage distance arrester housings are available. Manual hot washing of TRANQUELL™ arresters with a single stream of pressurized, de-ionized water is permissible, provided electric utility industry accepted safety precautions are observed.

Arrester Failure & Pressure Relief

In the event that the capability of a GE TRANQUELL™ arrester is exceeded, the metal oxide disks may crack or puncture. Such damage may reduce the arrester's internal electrical resistance. Although this will limit the arrester's ability to survive future system conditions, it does not jeopardize the insulation protection provided by the arrester.

In the unlikely case of complete failure of the arrester, a line-to-ground arc will develop and pressure will build up inside the housing. This pressure will be safely vented to the outside and an external arc will be established provided the fault current is within the pressure relief fault current capability of the arrester. This low-voltage arc maintains equipment protection. All ratings of metal top porcelain station arresters will withstand a system available short circuit current of at least 65,000 amperes rms, symmetrical (169,000 amperes, first crest) in accordance with the test procedures outlined in ANSI/IEEE C62.11. Porcelain pressure relief/fault current capability for all GE TRANQUELL™ arresters is shown in Table 5.

Once an arrester has safely vented, it no longer possesses its pressure relief/ fault current capability. An arrester that has vented should be replaced immediately.

For a given application, the arrester to be selected should have a pressure relief/fault current capability greater than the maximum short-circuit current available at the intended arrester location including appropriate allowances for system growth. As with any porcelain arrester, the pressure relief apertures should be oriented away from adjacent apparatus to minimize damage to that apparatus in case of a pressure relief operation.

Ambient Temperature

Ambient temperature is an important consideration in the application of metal oxide arresters. Metal oxide materials exhibit a temperature dependent loss characteristic; the higher the ambient temperature, the higher will be the disk temperature when the arrester is operated at its continuous voltage capability.

The referenced standards indicate that the ambient temperature not exceeding 40°C is the standard service condition for arresters.

Altitude

GE TRANQUELL™ arresters are designed for altitudes between 6,000 and 12,000 ft. (3600 m) above sea level, depending upon the specific model arrester. For higher altitude applications, extra clearances may be required in the design of the arrester housing. In general, the insulation design of the substation will dictate the arrester clearances. For each 1,000 ft. above a 10,000 ft. altitude, arrester clearances should increase approximately three percent.

Mounting Considerations

Grid Solutions' TRANQUELL™ arresters are designed to be self-supporting for base mounting in a vertical position. However, units for other mounting arrangements are available upon request. Arresters may be horizontally mounted if the cantilever loading, including arrester weight, icing, and terminal loads, does not exceed the maximum working cantilever strength. Where applicable, the pressure relief vents should be located on the underside of the arrester. Units for suspension mountings are also available.

The rated working cantilever strengths for various arrester ratings are shown in Table 6 and are defined in accordance with ANSI C29.9 [8]. The defined strengths exceed the requirements for US Seismic Zone 3 (< 0.2g). For arresters installed in higher zones, seismic requirements need to be specified.

In the installation of arresters, recommended clearances between the arrester and any adjacent equipment must be observed. Failure to do so may result in unwanted flashovers and electrical overstress to internal arrester elements.

GE TRANQUELL™ arresters are designed to have a uniform voltage gradient along the length of the porcelain column. Where applicable, a grading ring is mounted on top of the arrester to establish a more uniform voltage distribution along the arrester. Clearly, if the arrester were mounted adjacent to a ground plane, this uniformity would be disturbed. To avoid such a situation, the minimum clearances to ground planes and other phase conductors must be observed.

Field Testing

In general, it is impractical to fully test an arrester in the field without high-voltage test equipment and accurate instrumentation. Instead, the arrester leakage current can be used to monitor the over-all state or condition of the arrester. For example, an abnormal leakage current measurement can be indicative of a wet, surface-contaminated, or vented arrester.

Arrester leakage current can be monitored by a surge-counter leakage meter or by an oscilloscope connected directly to a surgecounter test connection. Typical arrester leakage currents of station arresters operating at their continuous voltage capability and at 20°C are in the range of one-half to three milliamperes. Contamination of the arrester housing will contribute another component to the leakage current. If leakage current is to be used as an indication of arrester condition, the arrester must be clean, and the voltage and temperature must correspond to some standard test conditions, specific to each arrester location.

Arrester Selection Summary

The arrester selection process should include a review of all system stresses and service conditions expected at the arrester location. System stresses include continuous operating voltage, temporary overvoltages, and switching surges. If arresters of different ratings are required to meet these individual criteria, the highest resulting rating must be chosen. The arresters' capability for contamination, pressure relief, ambient temperature, and altitude must exceed the specified requirements. Once an arrester has been selected, the protection it provides to the equipment insulation can be determined. This protection is dependent on the protective characteristics of the arrester, the lightning and switching surges expected on the system, and the insulation characteristics of the protected equipment. It is quantified in terms of the protective ratio which is the ratio of the equipment insulation withstand to the arrester protective level. The objective is to meet or exceed the minimum protective ratios for the various classes of voltage surges as recommended in the application standards. An alternate measure is the percent protective margin which is the protective ratio minus one, times 100%. For example, a protective ratio of 1.53 corresponds to a 53% protective margin.

Arrester Protective Characteristics

The protective characteristic of Grid Solutions' TRANQUELL™ arresters is solely defined by the discharge voltage and is generally proportional to arrester MCOV. For any one arrester, the discharge voltage is a function of the magnitude of the arrester current and, in the impulse region, of the time to crest of the arrester current. In general, for any specific applied impulse current through the arrester, the time-to-crest for the voltage wave will be less than the time-to-crest for the current wave. Figure 1 shows the test results of a 10 kA 8/20 μ s current impulse test.

The TRANQUELL™ protective characteristics have been defined for fast impulse currents with times-to-crest shorter than 8 μ s. Available data on lightning strikes and simulation studies on impulse transients within substations both indicate that arresters in service may be subjected to fast current impulse waves. To illustrate arrester protection for slower transients, the discharge voltages have been defined for standard switching surge currents.

The arrester protective characteristic is a continuous function defined over a range of discharge currents and their resultant discharge voltages. The insulation withstand of equipment on the other hand, is generally defined only at three voltage points through the use of the standard switching surge, the full wave, and the chopped wave tests. To facilitate comparison with these three withstands, three protective levels are selected for coordination with the transformer insulation characteristics. They are described as follows:

- **Switching Surge Protective Level:** This is the crest discharge voltage that results when a 36/90-s current impulse is applied to the arrester. To define the arrester's switching surge protective level, a "switching surge coordination current" is defined for the various system voltages. These currents are: 500 amperes for maximum system line-to-line voltages to 150 kV, 1000 amperes for systems 151 to 325 kV, and 2000 amperes for systems above 325 kV.
- **Impulse Protective Level:** This is the crest discharge voltage that results when an 8/20 -s current impulse is applied to the arrester. The resultant crest voltages for a variety of crest currents are given in the applicable Arrester Characteristics Table. To allow coordination with transformer insulation, a

specific current impulse magnitude must be selected based on the system voltage. Reference [5] provides guidance for this selection.

- **Front-of-Wave Protective Level:** This is the discharge voltage for current impulses having a faster time to crest than the 8/20-s current impulse. This resultant crest voltage is listed as the front-of-wave (FOW) protective level. This protective level is derived by applying a series of current wave impulses to an arrester with varying times to crest (1, 2, 8 ms) and extending the measured voltages to 0.5 -s in accordance with ANSI/IEEE.

Protective Ratios

The three-point method is usually applied for insulation coordination. In this method the protective ratios are calculated at three separate points within the volt-time domain; namely switching surge, full wave, and chopped wave regions. If the following protective ratios are met or exceeded, satisfactory insulation coordination will be achieved according to the minimum recommendations given in ANSI C62.22.

| | |
|----------------------------------|-------------|
| <u>Switching Surge Withstand</u> | ≥ 1.15 |
| Switching Surge Protective Level | |
| <u>Full Wave Withstand (BIL)</u> | ≥ 1.20 |
| Impulse Protective Level | |
| <u>Chopped Wave Withstand</u> | ≥ 1.25 |
| Front-of-Wave Protective Level | |

These calculated protective ratios assume negligible arrester lead length and separation distance between the arrester and the transformer.

In many cases, the calculated protective ratios exceed the minimum protective ratios recommended by ANSI by a considerable amount in actual power system applications.

As a specific example in protective ratio calculation, consider a 550 kV BIL transformer protected by a 144 kV rated TRANQUELL™ polymer station surge arrester. The three transformer insulation withstand voltages are as specified in ANSI C57.12.00[9]. The calculated ratios indicate that the arrester would provide excellent protection for the transformer insulation.

If the separation distance between the transformer and arrester is not negligible, the transformer voltage can oscillate above the arrester voltage during lightning transients, thus reducing the protective ratio. Guidance in estimating these effects can be obtained from ANSI C62.22 and References [10] and [11]. When making such transformer voltage estimates for shielded stations, it is suggested that the front-of-wave protective level of the arrester be used as an approximation for the arrester voltage. In decisive situations, it is suggested that digital computer studies be performed in which the arrester and substation details can be modeled.

Figure 2

Arrester voltage and current osillograms for 10 kA, 8/20 μ s current impulse test

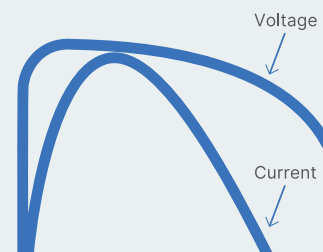

Table 6 - Cantilever Strength

| ARRESTER RATED VOLTAGE (kV) rms | HOUSING TYPE | ARRESTER SERIES | ARRESTER TYPE | RATED ULTIMATE CANTILEVER STRENGTH | | MAXIMUM WORKING CANTILEVER STRENGTH | |
|---------------------------------|--------------|-----------------|---------------|------------------------------------|--------|-------------------------------------|--------|
| | | | | in-lbs. | n-m | in-lbs. | n-m |
| 3 - 72 kV | Polymer | 9L11PPA/PPB | Intermediate | 4,000 | 452 | 2,000 | 226 |
| 90 - 114 kV | Polymer | 9L11PPA/PPB | Intermediate | 10,000 | 1,130 | 5,000 | 565 |
| 3 - 144 kV | Polymer | 9L11XPA/XPB | Station | 20,000 | 2,260 | 10,000 | 1,130 |
| 3 - 48 kV | Porcelain | 9L11ZGA | Station | 70,000 | 7,909 | 28,000 | 3,163 |
| 54 - 444 kV | Porcelain | 9L11ZTA | Station | 150,000 | 16,947 | 60,000 | 6,779 |
| 396 - 612 kV | Porcelain | 9L16GNS | Station | 275,000 | 31,070 | 110,000 | 12,428 |

Table 7

| TRANSFORMER INSULATION ARRESTER PROTECTIVE WITHSTAND AND TEST WAVE | ARRESTER PROTECTIVE WITHSTAND AND TEST |
|--|--|
| Switching Surge 250/2500 μs voltage | Switching Surge 36/90 μs current |
| Full wave 1.2/50 μs voltage wave | Impulse 8/20 μs current |
| Chopped wave 1.2/50 μs voltage | Front-of-wave 0.5μs current wave |

Table 8 — Example of a 144 kV Rated Protective Ration Calculation

| TRANSFORMER WITHSTAND TESTS | TRANSFORMER WITHSTAND VOLTAGES (kV) | ARRESTER PROTECTIVE LEVELS (kV) | PROTECTIVE RATIOS |
|-----------------------------|-------------------------------------|---------------------------------|-------------------|
| Switching Surge | 460 | 285 | 1.61 |
| Full Wave | 550 | 351 | 1.57 |
| Chopped Wave | 630 | 386.1 | 1.63 |

Polymer Station Class

Electrical Characteristics — Four hole NEMA and Eyebolt - for Indoor and Outdoor

| STANDARD ARRESTER CATALOG NUMBER | | ARRESTER RATINGS | | | | MAXIMUM DISCHARGE VOLTAGE - 8/20 CURRENT WAVE-kV | | | | | |
|----------------------------------|------------------|------------------------|---|---|--|--|-------|-------|-------|-------|-------|
| 4 HOLE NEMA | EYEBOLT TERMINAL | RATED VOLTAGE (kV) rms | MAXIMUM CONTINUOUS OPERATING VOLTAGE (MCOV) (kV) ⁽¹⁾ | MAXIMUM 0.5 μ s DISCHARGE VOLTAGE kV ⁽¹⁾ | MAXIMUM SWITCHING SURGE PROTECTIVE LEVEL kV ⁽²⁾ | 1.5 kA | 3 kA | 5 kA | 10 kA | 20 kA | 40 kA |
| 9L11XPA003S | 9L11XPB003S | 3 | 2.55 | 8.4 | 6 | 6.4 | 6.7 | 7.1 | 7.6 | 8.4 | 9.6 |
| 9L11XPA006S | 9L11XPB006S | 6 | 5.1 | 16.7 | 11.9 | 12.8 | 13.5 | 14.1 | 15.2 | 16.8 | 19.1 |
| 9L11XPA009S | 9L11XPB009S | 9 | 7.65 | 25 | 17.8 | 19.2 | 20.2 | 21.1 | 22.7 | 25.1 | 28.3 |
| 9L11XPA010S | 9L11XPB010S | 10 | 8.4 | 27.8 | 19.8 | 21.4 | 22.5 | 23.5 | 25.3 | 28 | 31.8 |
| 9L11XPA012S | 9L11XPB012S | 12 | 10.2 | 33.3 | 23.7 | 25.6 | 26.9 | 28.1 | 30.3 | 33.5 | 38.1 |
| 9L11XPA015S | 9L11XPB015S | 15 | 12.7 | 41.7 | 29.7 | 32 | 33.7 | 35.2 | 37.9 | 42 | 47.6 |
| 9L11XPA018S | 9L11XPB018S | 18 | 15.3 | 50.1 | 35.6 | 38.4 | 40.4 | 42.3 | 45.5 | 50.4 | 57.2 |
| 9L11XPA021S | 9L11XPB021S | 21 | 17 | 56.3 | 40.1 | 43.2 | 45.5 | 47.6 | 51.2 | 56.7 | 64.4 |
| 9L11XPA024S | 9L11XPB024S | 24 | 19.5 | 63.9 | 45.5 | 49.1 | 51.6 | 54 | 58.1 | 64.3 | 73 |
| 9L11XPA027S | 9L11XPB027S | 27 | 22 | 72.9 | 51.9 | 56 | 58.9 | 61.6 | 66.3 | 73.4 | 83.3 |
| 9L11XPA030S | 9L11XPB030S | 30 | 24.4 | 80.4 | 57.2 | 61.7 | 64.9 | 67.9 | 73.1 | 80.9 | 91.9 |
| 9L11XPA036S | 9L11XPB036S | 36 | 29 | 95.9 | 68.3 | 73.6 | 77.4 | 81 | 87.2 | 96.5 | 109.6 |
| 9L11XPA039S | 9L11XPB039S | 39 | 31.5 | 104.2 | 74.2 | 80 | 84.1 | 88 | 94.7 | 104.8 | 119 |
| 9L11XPA045S | 9L11XPB045S | 45 | 36.5 | 120.9 | 86.1 | 92.8 | 97.6 | 102.1 | 109.9 | 121.7 | 138.1 |
| 9L11XPA048S | 9L11XPB048S | 48 | 39 | 128.7 | 91.6 | 98.8 | 103.9 | 108.7 | 117 | 129.5 | 147.1 |
| 9L11XPA054S | 9L11XPB054S | 54 | 42 | 144.4 | 102.8 | 110.9 | 116.6 | 122 | 131.3 | 145.3 | 165 |
| 9L11XPA060S | 9L11XPB060S | 60 | 48 | 163.5 | 116.4 | 125.5 | 132 | 138 | 148.6 | 164.5 | 186.8 |
| 9L11XPA072S | 9L11XPB072S | 72 | 57 | 191.8 | 136.6 | 147.3 | 154.9 | 162 | 174.4 | 193.1 | 219.2 |
| 9L11XPA090S | 9L11XPB090S | 90 | 70 | 241.8 | 172.1 | 185.6 | 195.2 | 204.2 | 219.8 | 243.3 | 276.3 |
| 9L11XPA096S | 9L11XPB096S | 96 | 76 | 257.4 | 183.2 | 197.6 | 207.8 | 217.4 | 234 | 259 | 294.1 |
| 9L11XPA108S | 9L11XPB108S | 108 | 84 | 288.9 | 205.6 | 221.8 | 233.2 | 244 | 262.6 | 290.7 | 330.1 |
| 9L11XPA120S | 9L11XPB120S | 120 | 98 | 326.9 | 241.3 | 251 | 263.9 | 276.1 | 297.2 | 329 | 373.6 |
| 9L11XPA132S | 9L11XPB132S | 132 | 106 | 352 | 252 | 270 | 284 | 298 | 317 | 353 | 404 |
| 9L11XPA144S | 9L11XPB144S | 144 | 115 | 386.1 | 285 | 296.5 | 311.7 | 326.1 | 351 | 388.6 | 441.2 |
| 9L11XPA168S | 9L11XPB168S | 168 | 131 | 445 | 330 | 343 | 363 | 380 | 409 | 446 | 503 |
| 9L11XPA172S | 9L11XPB172S | 172 | 140 | 455 | 338 | 351 | 372 | 389 | 419 | 457 | 516 |
| 9L11XPA180S | 9L11XPB180S | 180 | 144 | 476 | 354 | 367 | 389 | 407 | 438 | 478 | 539 |
| 9L11XPA192S | 9L11XPB192S | 192 | 152 | 508 | 377 | 391 | 415 | 434 | 467 | 509 | 575 |
| 9L11XPA228S | 9L11XPB228S | 228 | 180 | 604 | 448 | 465 | 493 | 516 | 556 | 607 | 684 |

¹ Maximum discharge voltage for a 10 kA impulse current wave which produces a voltage wave cresting in 0.5 μ s. This can be used for coordination where front-of-wave sparkover was formerly used.

² Based on a 500 A surge of 45- μ s time to crest through 88 kV MCOV, and of 45- μ s time to crest for 98 kV MCOV and higher ratings.

Physical Characteristics — Four Hole NEMA - for Indoor and Outdoor

| STANDARD ARRESTER CATALOG NUMBER | | ARRESTER RATINGS | | | | | INSULATION WITHSTAND DISTANCE | | | | | |
|----------------------------------|------------|------------------|------------|------|-----------------|-------------------------|-------------------------------|--------|-----------------|--------|--------|------|
| 4-HOLE | DUTY CYCLE | MCOV (kV) rms | HEIGHT "X" | | POLYMER Drawing | CREEPAGE DISTANCE in/mm | PHASE-TO-PHASE | | PHASE-TO-GROUND | | WEIGHT | |
| | | | in | mm | | | in | mm | in | mm | lbs | kg |
| 9L11XPA003S | 3 | 2.55 | 13.7 | 348 | 1 | 23 | 12.3 | 312.4 | 7.7 | 195.58 | 20.3 | 9.2 |
| 9L11XPA006S | 6 | 5.1 | 13.7 | 348 | 1 | 23 | 12.3 | 312.4 | 7.7 | 195.58 | 20.8 | 9.4 |
| 9L11XPA009S | 9 | 7.65 | 13.7 | 348 | 1 | 23 | 12.3 | 312.4 | 7.7 | 195.58 | 21.3 | 9.7 |
| 9L11XPA010S | 10 | 8.4 | 13.7 | 348 | 1 | 23 | 12.3 | 312.4 | 7.7 | 195.58 | 21.6 | 9.8 |
| 9L11XPA012S | 12 | 10.2 | 16.3 | 414 | 1 | 31 | 12.3 | 312.4 | 7.7 | 195.58 | 25.2 | 11.4 |
| 9L11XPA015S | 15 | 12.7 | 16.3 | 414 | 1 | 31 | 12.3 | 312.4 | 7.7 | 195.58 | 25.8 | 11.7 |
| 9L11XPA018S | 18 | 15.3 | 16.3 | 414 | 1 | 31 | 12.3 | 312.4 | 7.7 | 195.58 | 26.3 | 11.9 |
| 9L11XPA021S | 21 | 17 | 21.7 | 551 | 1 | 46 | 12.3 | 312.4 | 7.7 | 195.58 | 33.6 | 15.2 |
| 9L11XPA024S | 24 | 19.5 | 21.7 | 551 | 1 | 46 | 12.3 | 312.4 | 8 | 203.52 | 34.2 | 15.5 |
| 9L11XPA027S | 27 | 22 | 21.7 | 551 | 1 | 46 | 12.3 | 312.4 | 8.8 | 223.52 | 34.7 | 15.7 |
| 9L11XPA030S | 30 | 24.4 | 21.7 | 551 | 1 | 46 | 12.3 | 312.4 | 9.6 | 243.84 | 35.2 | 16.0 |
| 9L11XPA036S | 36 | 29 | 27 | 686 | 1 | 62 | 13.8 | 350.5 | 11 | 279.4 | 36.5 | 16.5 |
| 9L11XPA039S | 39 | 31.5 | 27 | 686 | 1 | 62 | 14.6 | 370.8 | 11.8 | 299.72 | 43.5 | 19.7 |
| 9L11XPA045S | 45 | 36.5 | 27 | 686 | 1 | 62 | 16.3 | 414.0 | 13.5 | 342.9 | 44.4 | 20.1 |
| 9L11XPA048S | 48 | 39 | 27 | 686 | 1 | 62 | 17 | 431.8 | 14.2 | 360.68 | 45.2 | 20.5 |
| 9L11XPA054S | 54 | 42 | 32.3 | 820 | 1 | 78 | 18.6 | 472.4 | 15.8 | 401.32 | 52.6 | 23.8 |
| 9L11XPA060S | 60 | 48 | 32.3 | 820 | 1 | 78 | 20.6 | 523.2 | 17.8 | 452.12 | 53.6 | 24.3 |
| 9L11XPA072S | 72 | 57 | 48.1 | 1222 | 1 | 92 | 23.4 | 594.4 | 20.6 | 523.24 | 76.7 | 34.8 |
| 9L11XPA090S | 90 | 70 | 48.1 | 1222 | 1 | 124 | 27 | 685.8 | 24.5 | 622.3 | 77 | 34.9 |
| 9L11XPA096S | 96 | 76 | 48.1 | 1222 | 1 | 124 | 30.5 | 774.7 | 28 | 711.2 | 80 | 36.3 |
| 9L11XPA108S | 108 | 84 | 58.8 | 1494 | 2 | 156 | 44.5 | 1130.3 | 36.5 | 927.1 | 98.9 | 44.8 |
| 9L11XPA120S | 120 | 98 | 58.8 | 1494 | 2 | 156 | 49 | 1244.6 | 41 | 1041.4 | 101 | 45.8 |
| 9L11XPA132S | 132 | 106 | 69.3 | 1760 | 2 | 156 | 53 | 1346.2 | 45 | 1143 | 105 | 47.6 |
| 9L11XPA144S | 144 | 115 | 69.3 | 1760 | 2 | 186 | 56 | 1422.4 | 48 | 1219.2 | 120.1 | 54.4 |
| 9L11XPA168S | 168 | 131 | 87.9 | 2233 | 2 | 234 | 74 | 1879.6 | 60 | 1524 | 152 | 68.9 |
| 9L11XPA172S | 172 | 140 | 87.9 | 2233 | 2 | 234 | 77 | 1955.8 | 63 | 1600.2 | 152 | 68.9 |
| 9L11XPA180S | 180 | 144 | 87.9 | 2233 | 2 | 234 | 78 | 1981.2 | 64 | 1625.6 | 152 | 68.9 |
| 9L11XPA192S | 192 | 152 | 87.9 | 2233 | 2 | 234 | 84 | 2133.6 | 70 | 1778 | 152 | 68.9 |
| 9L11XPA228S | 228 | 180 | 115.7 | 2939 | 2 | 312 | 94 | 2387.6 | 80 | 2032 | 201 | 91.1 |

Drawing 1 (Polymer)

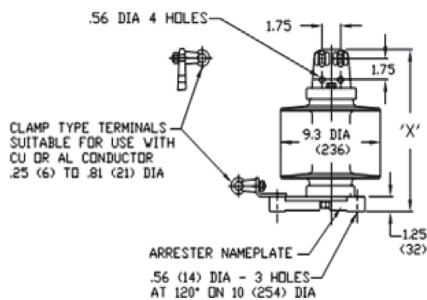

Drawing 2 (Polymer)

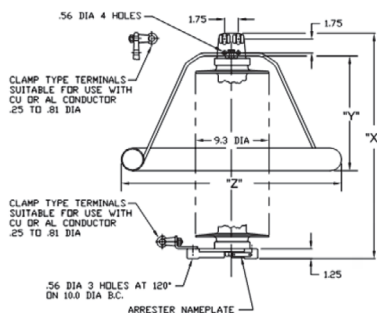

GRADING RINGS

| kV-Rated | Drop Inches (Y) | Diameter Inches (Z) |
|-----------|-----------------|---------------------|
| 108 | 4.8 | 14.0 |
| 120 - 144 | 9.0 | 16.5 |
| 168 - 228 | 14.5 | 27.9 |

Note: Grading rings are required on all arresters rated 108 kV and above.

XPA series arresters have 10-inch base bolt center.

Physical Characteristics — Eyebolt - for Indoor and Outdoor⁽³⁾

| STANDARD ARRESTER CATALOG NUMBER | | ARRESTER RATINGS | | | | | | INSULATION WITHSTAND DISTANCE | | | | | |
|----------------------------------|------------|------------------|------------|------|-----------------|-------------------|------|-------------------------------|--------|-----------------|--------|--------|------|
| 4-HOLE | DUTY CYCLE | MCOV (kV) rms | HEIGHT "X" | | POLYMER Drawing | CREEPAGE DISTANCE | | PHASE-TO-PHASE | | PHASE-TO-GROUND | | WEIGHT | |
| | | | in | mm | | in | mm | in | mm | in | mm | lbs | kg |
| 9L11XPB003S | 3 | 2.55 | 10.2 | 259 | 1A | 23 | 584 | 12.3 | 312.4 | 7.7 | 195.58 | 20.3 | 9.2 |
| 9L11XPB006S | 6 | 5.1 | 10.2 | 259 | 1A | 23 | 584 | 12.3 | 312.4 | 7.7 | 195.58 | 20.8 | 9.4 |
| 9L11XPB009S | 9 | 7.65 | 10.2 | 259 | 1A | 23 | 584 | 12.3 | 312.4 | 7.7 | 195.58 | 21.3 | 9.7 |
| 9L11XPB010S | 10 | 8.4 | 10.2 | 259 | 1A | 23 | 584 | 12.3 | 312.4 | 7.7 | 195.58 | 21.6 | 9.8 |
| 9L11XPB012S | 12 | 10.2 | 12.8 | 325 | 1A | 31 | 787 | 12.3 | 312.4 | 7.7 | 195.58 | 25.2 | 11.4 |
| 9L11XPB015S | 15 | 12.7 | 12.8 | 325 | 1A | 31 | 787 | 12.3 | 312.4 | 7.7 | 195.58 | 25.8 | 11.7 |
| 9L11XPB018S | 18 | 15.3 | 12.8 | 325 | 1A | 31 | 787 | 12.3 | 312.4 | 7.7 | 195.58 | 26.3 | 11.9 |
| 9L11XPB021S | 21 | 17 | 18.2 | 462 | 1A | 46 | 1168 | 12.3 | 312.4 | 7.7 | 195.58 | 33.6 | 15.2 |
| 9L11XPB024S | 24 | 19.5 | 18.2 | 462 | 1A | 46 | 1168 | 12.3 | 312.4 | 8 | 203.52 | 34.2 | 15.5 |
| 9L11XPB027S | 27 | 22 | 18.2 | 462 | 1A | 46 | 1168 | 12.3 | 312.4 | 8.8 | 223.52 | 34.7 | 15.7 |
| 9L11XPB030S | 30 | 24.4 | 18.2 | 462 | 1A | 46 | 1168 | 12.3 | 312.4 | 9.6 | 243.84 | 35.2 | 16.0 |
| 9L11XPB036S | 36 | 29 | 18.2 | 462 | 1A | 46 | 1168 | 13.8 | 350.5 | 11 | 279.4 | 36.5 | 16.5 |
| 9L11XPB039S | 39 | 31.5 | 23.5 | 597 | 1A | 62 | 1575 | 14.6 | 370.8 | 11.8 | 299.72 | 43.5 | 19.7 |
| 9L11XPB045S | 45 | 36.5 | 23.5 | 597 | 1A | 62 | 1575 | 16.3 | 414.0 | 13.5 | 342.9 | 44.4 | 20.1 |
| 9L11XPB048S | 48 | 39 | 23.5 | 597 | 1A | 62 | 1575 | 17 | 431.8 | 14.2 | 360.68 | 45.2 | 20.5 |
| 9L11XPB054S | 54 | 42 | 28.8 | 732 | 1A | 78 | 1981 | 18.6 | 472.4 | 15.8 | 401.32 | 52.6 | 23.8 |
| 9L11XPB060S | 60 | 48 | 28.8 | 732 | 1A | 78 | 1981 | 20.6 | 523.2 | 17.8 | 452.12 | 53.6 | 24.3 |
| 9L11XPB072S | 72 | 57 | 34 | 864 | 1A | 92 | 2337 | 23.4 | 594.4 | 20.6 | 523.24 | 76.7 | 34.8 |
| 9L11XPB090S | 90 | 70 | 44.6 | 1133 | 1A | 124 | 3150 | 27 | 685.8 | 24.5 | 622.3 | 77 | 34.9 |
| 9L11XPB096S | 96 | 76 | 44.6 | 1133 | 1A | 124 | 3150 | 30.5 | 774.7 | 28 | 711.2 | 80 | 36.3 |
| 9L11XPB108S | 108 | 84 | 55.3 | 1405 | 2A | 156 | 3962 | 44.5 | 1130.3 | 36.5 | 927.1 | 98.9 | 44.8 |
| 9L11XPB120S | 120 | 98 | 55.3 | 1405 | 2A | 156 | 3962 | 49 | 1244.6 | 41 | 1041.4 | 101 | 45.8 |
| 9L11XPB132S | 132 | 106 | 55.3 | 1405 | 2A | 156 | 3962 | 53 | 1346.2 | 45 | 1143 | 105 | 47.6 |
| 9L11XPB144S | 144 | 115 | 65.8 | 1671 | 2A | 186 | 4724 | 56 | 1422.4 | 48 | 1219.2 | 120.1 | 54.4 |
| 9L11XPB168S | 168 | 131 | 84.4 | 2144 | 2A | 234 | 5944 | 74 | 1879.6 | 60 | 1524 | 152 | 68.9 |
| 9L11XPB172S | 172 | 140 | 84.4 | 2144 | 2A | 234 | 5944 | 77 | 1955.8 | 63 | 1600.2 | 152 | 68.9 |
| 9L11XPB180S | 180 | 144 | 84.4 | 2144 | 2A | 234 | 5944 | 78 | 1981.2 | 64 | 1625.6 | 152 | 68.9 |
| 9L11XPB192S | 192 | 152 | 84.4 | 2144 | 2A | 234 | 5944 | 84 | 2133.6 | 70 | 1778 | 152 | 68.9 |
| 9L11XPB228S | 228 | 180 | 112.2 | 2850 | 2A | 312 | 7925 | 94 | 2387.6 | 80 | 2032 | 201 | 91.1 |

Drawing 1 (Polymer)

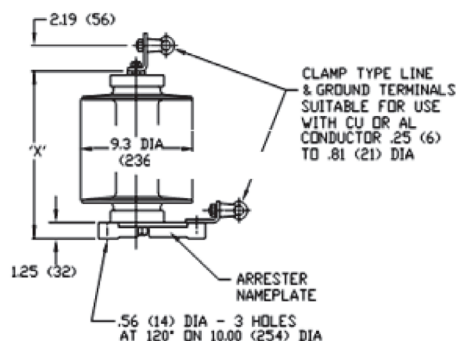

Drawing 2 (Polymer)

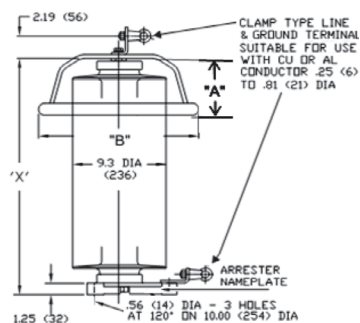

GRADING RINGS

| kV-Rated | Drop Inches (Y) | Diameter Inches (Z) |
|-----------|-----------------|---------------------|
| 108 - 120 | 4.8 | 14.0 |
| 132 - 144 | 9.0 | 16.5 |
| 168 - 228 | 14.5 | 27.9 |

Note: Grading rings are required on all arresters rated 108 kV and above.

Electrical Characteristics — Four Hole NEMA - for Indoor and Outdoor Upright Mounting

| ARRESTER RATINGS | | | | | MAXIMUM DISCHARGE VOLTAGE USING 8/20 CURRENT WAVE-kV | | | | | |
|-------------------------|--------------------|--|---|--|--|------|------|-------|-------|-------|
| ARRESTER CATALOG NUMBER | RATED VOLTAGE (kV) | MAXIMUM CONTINUOUS OPERATING VOLTAGE (MCOV) (kV) rms | MAXIMUM 0.5µs DISCHARGE VOLTAGE kV ⁽¹⁾ | MAXIMUM SWITCHING SURGE PROTECTIVE LEVEL kV ⁽²⁾ | 1.5 kA | 3 kA | 5 kA | 10 kA | 20 kA | 40 kA |
| 9L11ZGA003S | 3 | 2.55 | 9.1 | 6.3 | 6.9 | 7.2 | 7.5 | 8 | 9 | 10.3 |
| 9L11ZGA006S | 6 | 5.1 | 17.9 | 12.4 | 13.6 | 14.2 | 14.8 | 15.8 | 17.7 | 20.3 |
| 9L11ZGA009S | 9 | 7.65 | 26.6 | 18.4 | 20.2 | 21.1 | 22 | 23.5 | 26.4 | 30.2 |
| 9L11ZGA010S | 10 | 8.4 | 29.3 | 20.3 | 22.2 | 23.3 | 24.2 | 25.9 | 29.1 | 33.3 |
| 9L11ZGA012S | 12 | 10.2 | 35.5 | 24.6 | 26.9 | 28.2 | 29.4 | 31.4 | 35.2 | 40.4 |
| 9L11ZGA015S | 15 | 12.7 | 44.2 | 30.6 | 33.5 | 35.1 | 36.6 | 39.1 | 43.9 | 50.3 |
| 9L11ZGA018S | 18 | 15.3 | 53.3 | 36.8 | 40.4 | 42.3 | 44.1 | 47.1 | 52.8 | 60.6 |
| 9L11ZGA021S | 21 | 17 | 59.1 | 40.9 | 44.8 | 46.9 | 48.9 | 52.3 | 58.7 | 67.2 |
| 9L11ZGA024S | 24 | 19.5 | 67.8 | 46.9 | 51.4 | 53.8 | 56.1 | 60 | 67.3 | 77.1 |
| 9L11ZGA027S | 27 | 22 | 76.5 | 52.9 | 58 | 60.8 | 63.3 | 67.7 | 75.9 | 87 |
| 9L11ZGA030S | 30 | 24.4 | 84.9 | 58.7 | 64.3 | 67.4 | 70.3 | 75.1 | 84.2 | 96.5 |
| 9L11ZGA036S | 36 | 29 | 101 | 69.7 | 76.4 | 80 | 83.4 | 89.2 | 100 | 115 |
| 9L11ZGA039S | 39 | 31.5 | 110 | 75.8 | 83 | 86.9 | 90.6 | 96.9 | 109 | 125 |
| 9L11ZGA045S | 45 | 36.5 | 128 | 88.3 | 96.8 | 102 | 106 | 113 | 127 | 146 |
| 9L11ZGA048S | 48 | 39 | 136 | 93.8 | 103 | 108 | 113 | 120 | 135 | 155 |
| 9L11ZTA054S | 54 | 42 | 135 | 100 | 107 | 112 | 117 | 125 | 136 | 151 |
| 9L11ZTA060S | 60 | 48 | 150 | 111 | 119 | 125 | 130 | 139 | 151 | 168 |
| 9L11ZTA072S | 72 | 57 | 178 | 132 | 141 | 148 | 154 | 165 | 179 | 199 |
| 9L11ZTA090S | 90 | 70 | 225 | 166 | 178 | 187 | 195 | 208 | 226 | 251 |
| 9L11ZTA096S | 96 | 76 | 238 | 176 | 188 | 198 | 206 | 220 | 239 | 265 |
| 9L11ZXA108S | 108 | 84 | 238 | 176 | 188 | 198 | 206 | 220 | 239 | 265 |
| 9L11ZTA108S | 108 | 88 | 275 | 203 | 218 | 228 | 238 | 254 | 276 | 306 |
| 9L11ZTA120S | 120 | 98 | 269 | 199 | 213 | 224 | 233 | 249 | 270 | 300 |
| 9L11ZTA132S | 132 | 106 | 275 | 203 | 218 | 228 | 238 | 254 | 276 | 306 |
| 9L11ZTA144S | 144 | 115 | 306 | 235 | 242 | 254 | 265 | 283 | 307 | 341 |
| 9L11ZTA168S | 168 | 131 | 332 | 254 | 263 | 276 | 287 | 307 | 333 | 370 |
| 9L11ZTA172S | 172 | 140 | 360 | 276 | 285 | 299 | 312 | 333 | 361 | 402 |
| 9L11ZTA180S | 180 | 144 | 416 | 319 | 330 | 346 | 360 | 385 | 418 | 464 |
| 9L11ZTA192S | 192 | 152 | 438 | 336 | 347 | 363 | 379 | 405 | 439 | 488 |
| 9L11ZTA228S | 228 | 180 | 450 | 345 | 357 | 374 | 390 | 416 | 452 | 502 |
| 9L11ZTA258S | 258 | 209 | 659 | 526 | 522 | 547 | 570 | 609 | 661 | 735 |
| 9L11ZTA264S | 264 | 212 | 662 | 528 | 524 | 550 | 573 | 612 | 664 | 738 |
| 9L11ZTA276S | 276 | 220 | 687 | 548 | 544 | 570 | 594 | 635 | 689 | 766 |
| 9L11ZTA288S | 288 | 234 | 728 | 581 | 577 | 605 | 630 | 673 | 731 | 812 |
| 9L11ZTA294S | 294 | 237 | 743 | 593 | 589 | 617 | 643 | 687 | 746 | 829 |
| 9L11ZTA300S | 300 | 243 | 759 | 606 | 601 | 630 | 657 | 702 | 762 | 846 |
| 9L11ZTA312S | 312 | 245 | 773 | 617 | 612 | 641 | 668 | 714 | 775 | 862 |
| 9L11ZTA336S | 336 | 264 | 833 | 665 | 659 | 690 | 719 | 767 | 835 | 929 |
| 9L11ZTA360S | 360 | 288 | 933 | 734 | 732 | 771 | 798 | 849 | 945 | 1053 |
| 9L11ZTA396S | 396 | 318 | 1139 | 816 | 822 | 861 | 897 | 959 | 1055 | — |
| 9L11ZTA420S | 420 | 335 | 1278 | 901 | 900 | 945 | 986 | 1058 | 1164 | — |
| 9L11ZTA444S | 444 | 353 | 1351 | 953 | 952 | 999 | 1043 | 1199 | 1231 | — |
| 9L16GNS588S | 588 | 470 | | | | | | | | |
| 9L16GNS612S | 612 | 485 | | | | | | | | |
| 9L16GNS588S | 588 | 470 | | | | | | | | |
| 9L16GNS612S | 612 | 485 | | | | | | | | |

¹ Maximum discharge voltage for an impulse current wave which produces a voltage wave cresting in 0.5 µs. Discharge currents are 10 kA for 2.55 - 245 kV MCOV. This can be used for coordination where front-of-wave sparkover formerly was used

² Discharge voltages are based on a 500 A surge of 45 µs time to crest through 88 kV MOV and 1,000 A surge of 45 µs-time to crest through 180 kV MCOV and 2,000 A through 245 kV MCOV.

Electrical Characteristics — Top Eyebolt - For Indoor or Cubicle Mounting

| TYPE | ARRESTER RATINGS | | | | MAXIMUM DISCHARGE VOLTAGE USING 8/20 CURRENT WAVE-kV | | | | | | |
|---|-------------------------|--------------------|--|---|--|--------|------|------|-------|-------|-------|
| | ARRESTER CATALOG NUMBER | RATED VOLTAGE (kV) | MAXIMUM CONTINUOUS OPERATING VOLTAGE (MCOV) (kV) rms | MAXIMUM 0.5 μ s DISCHARGE VOLTAGE kV ⁽¹⁾ | MAXIMUM SWITCHING SURGE PROTECTIVE LEVEL kV ⁽²⁾ | 1.5 kA | 3 kA | 5 kA | 10 kA | 20 kA | 40 kA |
| Porcelain Top (eyebolt) Indoor/ Cubicle | 9L11ZGB003S | 3 | 2.55 | 9.1 | 6.3 | 6.9 | 7.2 | 7.5 | 8 | 9 | 10.3 |
| | 9L11ZGB006S | 6 | 5.1 | 17.9 | 12.4 | 13.6 | 14.2 | 14.8 | 15.8 | 17.7 | 20.3 |
| | 9L11ZGB009S | 9 | 7.65 | 26.6 | 18.4 | 20.2 | 21.1 | 22 | 23.5 | 26.4 | 30.2 |
| | 9L11ZGB010S | 10 | 8.4 | 29.3 | 20.3 | 22.2 | 23.3 | 24.2 | 25.9 | 29.1 | 33.3 |
| | 9L11ZGB012S | 12 | 10.2 | 35.5 | 24.6 | 26.9 | 28.2 | 29.4 | 31.4 | 35.2 | 40.4 |
| | 9L11ZGB015S | 15 | 12.7 | 44.2 | 30.6 | 33.5 | 35.1 | 36.6 | 39.1 | 43.9 | 50.3 |
| | 9L11ZGB018S | 18 | 15.3 | 53.3 | 36.8 | 40.4 | 42.3 | 44.1 | 47.1 | 52.8 | 60.6 |
| | 9L11ZGB021S | 21 | 17 | 59.1 | 40.9 | 44.8 | 46.9 | 48.9 | 52.3 | 58.7 | 67.2 |
| | 9L11ZGB024S | 24 | 19.5 | 67.8 | 46.9 | 51.4 | 53.8 | 56.1 | 60 | 67.3 | 77.1 |
| | 9L11ZGB027S | 27 | 22 | 76.5 | 52.9 | 58.0 | 60.8 | 63.3 | 67.7 | 75.9 | 87.0 |

¹ Maximum discharge voltage for an impulse current wave which produces a voltage wave cresting in 0.5 μ s. Discharge currents are 10 kA for 2.55 - 245 kV MCOV. This can be used for coordination where front-of-wave sparkover formerly was used

² Discharge voltages are based on a 500 A surge of 45 μ s time to crest through 88 kV MOV and 1,000A surge of 45 μ s-time to crest through 180 kV MCOV and 2,000 A through 245 kV MCOV.

Physical Characteristics — Four Hole NEMA - for Indoor and Outdoor Upright Mounting

| STANDARD ARRESTER CATALOG NUMBER | DUTY CYCLE (kV) rms | MCOV (kV) rms | PORCELAIN | HEIGHT "X" | | CREEPAGE DISTANCE | | INSULATION WITHSTAND DISTANCE | | | | | |
|----------------------------------|---------------------|---------------|-----------|------------|--------|-------------------|---------|-------------------------------|--------|-----------------|--------|--------|-------|
| | | | | | | | | PHASE-TO-PHASE | | PHASE TO GROUND | | WEIGHT | |
| | | | | | | | | in | mm | in | mm | lbs | kg |
| | | | Drawing | in | mm | in | mm | in | mm | in | mm | lbs | kg |
| 9L11ZGA003S | 3 | 2.55 | 2 | 19.13 | 485.9 | 6.2 | 157.5 | 12 | 304.8 | 6 | 152.4 | 65 | 29.5 |
| 9L11ZGA006S | 6 | 5.1 | 2 | 19.13 | 485.9 | 6.2 | 157.5 | 12 | 304.8 | 7 | 177.8 | 65 | 29.5 |
| 9L11ZGA009S | 9 | 7.65 | 2 | 19.13 | 485.9 | 6.2 | 157.5 | 13 | 330.2 | 7 | 177.8 | 66 | 30.0 |
| 9L11ZGA010S | 10 | 8.4 | 2 | 19.13 | 485.9 | 6.2 | 157.5 | 13 | 330.2 | 7 | 203.2 | 66 | 30.0 |
| 9L11ZGA012S | 12 | 10.2 | 2 | 21.13 | 536.7 | 11.1 | 281.9 | 14 | 355.6 | 8.5 | 215.9 | 72 | 32.7 |
| 9L11ZGA015S | 15 | 12.7 | 2 | 21.13 | 536.7 | 11.1 | 281.9 | 14 | 355.6 | 8.5 | 215.9 | 73 | 33.2 |
| 9L11ZGA018S | 18 | 15.3 | 2 | 24.13 | 612.9 | 20 | 508.0 | 16 | 406.4 | 9 | 228.6 | 80 | 36.4 |
| 9L11ZGA021S | 21 | 17 | 2 | 24.13 | 612.9 | 20 | 508.0 | 16 | 406.4 | 9 | 228.6 | 81 | 36.8 |
| 9L11ZGA024S | 24 | 19.5 | 2 | 24.13 | 612.9 | 20 | 508.0 | 17 | 431.8 | 11 | 279.4 | 82 | 37.3 |
| 9L11ZGA027S | 27 | 22 | 2 | 28.13 | 715.5 | 31.7 | 805.2 | 18 | 457.2 | 12 | 304.8 | 90 | 40.9 |
| 9L11ZGA030S | 30 | 24.4 | 2 | 28.13 | 715.5 | 31.7 | 805.2 | 18 | 457.2 | 12 | 304.8 | 91 | 41.4 |
| 9L11ZGA036S | 36 | 29 | 2 | 28.13 | 715.5 | 31.7 | 805.2 | 20 | 508 | 14 | 355.6 | 93 | 42.3 |
| 9L11ZGA039S | 39 | 31.5 | 2 | 31.88 | 809.8 | 41 | 1041.4 | 21 | 533.4 | 14 | 355.6 | 105 | 47.7 |
| 9L11ZGA045S | 45 | 36.5 | 2 | 31.88 | 809.8 | 41 | 1041.4 | 21 | 533.4 | 15 | 381 | 107 | 48.6 |
| 9L11ZGA048S | 48 | 39 | 2 | 31.88 | 809.8 | 41 | 1041.4 | 22 | 558.8 | 15 | 381 | 109 | 49.5 |
| 9L11ZTA054S | 54 | 42 | 3 | 38.13 | 968.5 | 60 | 1524 | 24 | 609.6 | 18 | 457.2 | 180 | 81.8 |
| 9L11ZTA060S | 60 | 48 | 3 | 38.13 | 968.5 | 60 | 1524 | 25 | 635 | 19 | 482.6 | 185 | 84.1 |
| 9L11ZTA066S | | | 3 | 44.13 | 1120.9 | 80 | 2032 | 26 | 660.4 | 20 | 508 | 220 | 100.0 |
| 9L11ZTA072S | 72 | 57 | 3 | 50.63 | 1286.0 | 101 | 2032 | 33 | 838.2 | 27 | 685.8 | 250 | 113.6 |
| 9L11ZTA090S | 90 | 70 | 3 | 50.63 | 1286.0 | 101 | 2032 | 35 | 889 | 29 | 736.6 | 260 | 118.2 |
| 9L11ZTA096S | 96 | 76 | 3 | 50.63 | 1286.0 | 101 | 2032 | 37 | 939.8 | 31 | 787.4 | 265 | 120.5 |
| 9L11ZXA108S | 108 | 84 | 3 | 57.13 | 1451.1 | 122 | 3098.8 | 38 | 965.2 | 32 | 812.8 | 280 | 127.3 |
| 9L11ZTA108S | 108 | 88 | 3 | 57.13 | 1451.1 | 122 | 3098.8 | 39 | 990.6 | 33 | 838.2 | 285 | 129.6 |
| 9L11ZTA120S | 120 | 98 | 3 | 57.13 | 1451.1 | 122 | 3098.8 | 42 | 1066.8 | 36 | 914.4 | 290 | 131.8 |
| 9L11ZTA132S | 132 | 106 | 4 | 76.63 | 1946.4 | 140 | 3556 | 44 | 1117.6 | 38 | 965.2 | 395 | 179.6 |
| 9L11ZTA144S | 144 | 115 | 4 | 82.63 | 1946.4 | 140 | 3556 | 51 | 1295.4 | 46 | 1168.4 | 425 | 193.2 |
| 9L11ZTA168S | 168 | 131 | 4 | 89.13 | 2263.9 | 181 | 4597.4 | 59 | 1498.6 | 54 | 1371.6 | 465 | 211.4 |
| 9L11ZTA172S | 172 | 140 | 5 | 89.13 | 2263.9 | 181 | 4597.4 | 78 | 1981.2 | 59 | 1498.6 | 475 | 215.9 |
| 9L11ZTA180S | 180 | 144 | 5 | 89.13 | 2263.9 | 181 | 4597.4 | 83 | 2108.2 | 64 | 1625.6 | 480 | 218.2 |
| 9L11ZTA192S | 192 | 152 | 5 | 96.13 | 2441.7 | 202 | 5130.8 | 83 | 2108.2 | 67 | 1701.8 | 515 | 234.1 |
| 9L11ZTA228S | 228 | 180 | 5 | 108.63 | 2759.2 | 244 | 6197.6 | 92 | 2336.8 | 73 | 1854.2 | 590 | 268.2 |
| 9L11ZTA240S | 240 | 194 | 5 | 108.63 | 2759.2 | 244 | 6197.6 | 103 | 2616.2 | 85 | 2159 | 595 | 270.5 |
| 9L11ZTA258S | 258 | 209 | 6 | 128.13 | 3254.5 | 262 | 6654.8 | 111 | 2819.4 | 92 | 2336.8 | 700 | 318.2 |
| 9L11ZTA264S | 264 | 212 | 6 | 133.63 | 3394.2 | 282 | 7162.8 | 116 | 2946.4 | 96 | 2438.4 | 725 | 329.6 |
| 9L11ZTA276S | 276 | 220 | 6 | 133.63 | 3394.2 | 282 | 7162.8 | 120 | 3048 | 100 | 2540 | 730 | 331.8 |
| 9L11ZTA288S | 288 | 234 | 6 | 140.63 | 3572.0 | 303 | 7696.2 | 128 | 3251.2 | 106 | 2692.4 | 775 | 325.3 |
| 9L11ZTA294S | 294 | 237 | 6 | 140.63 | 3572.0 | 303 | 7696.2 | 130 | 3302.0 | 110 | 2794.0 | 786 | 357.3 |
| 9L11ZTA300S | 300 | 243 | 6 | 140.63 | 3572.0 | 303 | 7696.2 | 130 | 3302.0 | 110 | 2794.0 | 785 | 356.8 |
| 9L11ZTA312S | 312 | 245 | 6 | 147.13 | 3737.1 | 324 | 8229.6 | 130 | 3302 | 110 | 2794 | 800 | 362.6 |
| 9L11ZTA336S | 336 | 264 | 6 | 150.1 | 3812.5 | 340 | 8636 | — | — | — | — | — | — |
| 9L11ZTA360S | 360 | 288 | 6 | 160.1 | 4067.3 | 366 | 9296.4 | — | — | — | — | — | — |
| 9L11ZTA396S | 396 | 318 | 7 | 192.1 | 4879.3 | 425 | 10795 | — | — | — | — | — | — |
| 9L11ZTA420S | 420 | 335 | 7 | 205.1 | 5210.3 | 467 | 11861.8 | — | — | — | — | — | — |
| 9L11ZTA444S | 444 | 353 | 7 | 205.1 | 5210.3 | 467 | 11861.8 | — | — | — | — | — | — |
| 9L16GNS588S | 588 | 470 | | | | | | | | | | | |
| 9L16GNS612S | 612 | 485 | | | | | | | | | | | |
| 9L16GNS588S | 588 | 470 | | | | | | | | | | | |
| 9L16GNS612S | 612 | 485 | | | | | | | | | | | |

Porcelain Physical Characteristics — Four Hole NEMA - for Indoor or Cubicle Upright Mounting

| STANDARD ARRESTER CATALOG NUMBER | DUTY CYCLE (kV) rms | MCOV (kV) rms | ARRESTER RATINGS | | | | | INSULATION WITHSTAND DISTANCE | | | | | |
|----------------------------------|---------------------|---------------|------------------|------------|-------|-------------------|-----------------|-------------------------------|-----------------|------|--------|-----|------|
| | | | PORCELAIN | HEIGHT "X" | | CREEPAGE DISTANCE | PHASE-TO -PHASE | | PHASE-TO-GROUND | | WEIGHT | | |
| | | | | Drawing | in | | mm | in | mm | in | mm | lbs | kg |
| 9L11ZGB003S | 3 | 2.55 | 1 | 12.0 | 304.8 | 11.1 | 281.9 | 11.0 | 279.4 | 5.5 | 139.7 | 35 | 15.9 |
| 9L11ZGB006S | 6 | 5.1 | 1 | 12.0 | 304.8 | 11.1 | 281.9 | 11.0 | 279.4 | 5.5 | 139.7 | 40 | 18.2 |
| 9L11ZGB009S | 9 | 7.65 | 1 | 12.0 | 304.8 | 11.1 | 281.9 | 11.0 | 279.4 | 5.5 | 139.7 | 40 | 18.2 |
| 9L11ZGB010S | 10 | 8.4 | 1 | 12.0 | 304.8 | 11.1 | 281.9 | 11.0 | 279.4 | 5.5 | 139.7 | 40 | 18.2 |
| 9L11ZGB012S | 12 | 10.2 | 1 | 12.0 | 304.8 | 11.1 | 281.9 | 11.0 | 279.4 | 6.5 | 165.1 | 40 | 18.2 |
| 9L11ZGB015S | 15 | 12.7 | 1 | 16.25 | 412.8 | 20.0 | 508.0 | 11.0 | 279.4 | 7.5 | 190.5 | 42 | 19.1 |
| 9L11ZGB018S | 18 | 15.3 | 1 | 16.25 | 412.8 | 20.0 | 508.0 | 11.0 | 279.4 | 9.0 | 228.6 | 50 | 22.7 |
| 9L11ZGB021S | 21 | 17 | 1 | 16.25 | 412.8 | 20.0 | 508.0 | 11.0 | 279.4 | 9.0 | 228.6 | 51 | 23.2 |
| 9L11ZGB024S | 24 | 19.5 | 1 | 16.25 | 412.8 | 20.0 | 508.0 | 11.0 | 279.4 | 9.0 | 228.6 | 52 | 23.6 |
| 9L11ZGB027S | 27 | 22 | 1 | 28.13 | 714.5 | 31.7 | 805.2 | 18.0 | 457.2 | 12.0 | 304.8 | 60 | 27.3 |

Porcelain Drawings

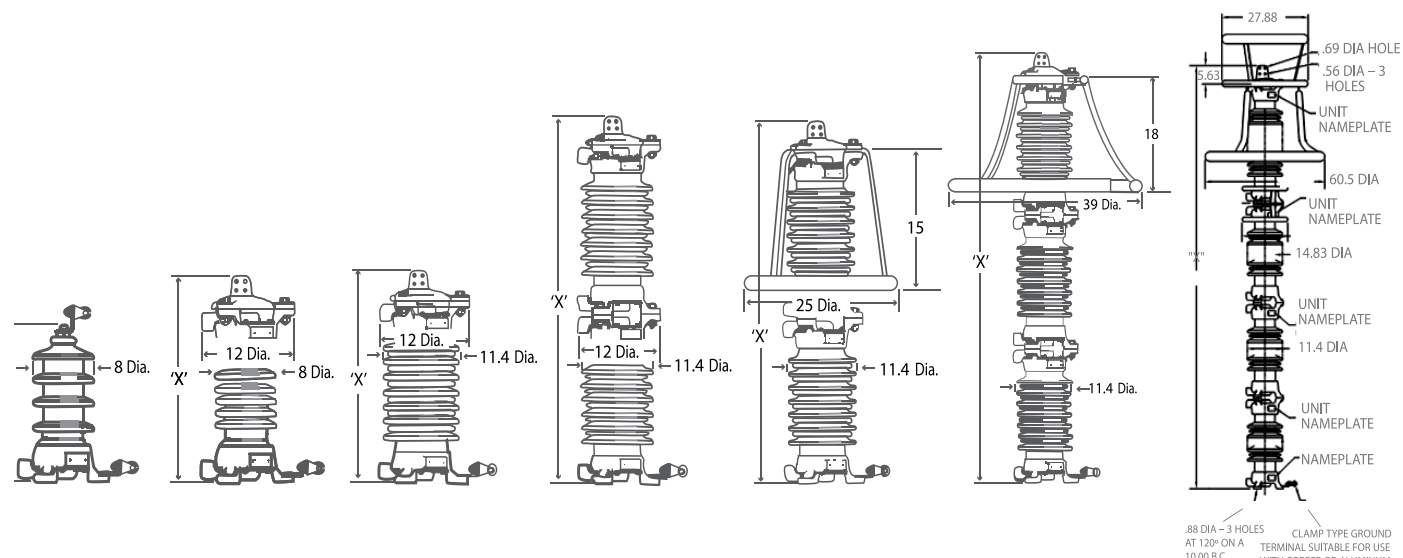

Drawing 1

Drawing 2

Drawing 3

Drawing 4

Drawing 5

Drawing 6

Drawing 7

Electrical Characteristics — Four Hole NEMA - for Indoor or Outdoor Mounting

| ARRESTER RATINGS | | | | | MAXIMUM DISCHARGE VOLTAGE USING 8/20 CURRENT WAVE-kV | | | | | |
|-------------------------|--------------------|--|---|--|---|------|------|-------|-------|-------|
| ARRESTER CATALOG NUMBER | RATED VOLTAGE (kV) | MAXIMUM CONTINUOUS OPERATING VOLTAGE (MCOV) (kV) rms | MAXIMUM 0.5µs DISCHARGE VOLTAGE kV ⁽¹⁾ | MAXIMUM SWITCHING SURGE PROTECTIVE LEVEL kV ⁽²⁾ | 1.5 kA | 3 kA | 5 kA | 10 kA | 20 kA | 40 kA |
| 9L11HMA054S | 54 | 42 | 133 | 94 | 103 | 108 | 113 | 121 | 131 | 146 |
| 9L11HMA060S | 60 | 48 | 152 | 107 | 118 | 124 | 129 | 138 | 150 | 166 |
| 9L11HMA072S | 72 | 57 | 181 | 127 | 140 | 147 | 153 | 164 | 178 | 198 |
| 9L11HMA090S | 90 | 70 | 222 | 156 | 172 | 181 | 188 | 201 | 218 | 243 |
| 9L11HMA090S | 90 | 74 | 235 | 165 | 182 | 191 | 199 | 213 | 231 | 256 |
| 9L11HMA096S | 96 | 76 | 241 | 170 | 187 | 196 | 205 | 218 | 237 | 263 |
| 9L11HMA108S | 108 | 84 | 266 | 187 | 207 | 217 | 226 | 241 | 262 | 291 |
| 9L11HMA108S | 108 | 88 | 279 | 196 | 217 | 227 | 237 | 253 | 274 | 305 |
| 9L11HMA120S | 120 | 98 | 311 | 228 | 241 | 253 | 264 | 282 | 305 | 340 |
| 9L11HMA132S | 132 | 106 | 335 | 247 | 261 | 274 | 285 | 305 | 330 | 367 |
| 9L11HMA144S | 144 | 115 | 365 | 268 | 283 | 297 | 310 | 330 | 358 | 399 |
| 9L11HMA168S | 168 | 131 | 416 | 305 | 323 | 338 | 353 | 376 | 408 | 454 |
| 9L11HMA172S | 172 | 140 | 444 | 326 | 345 | 362 | 377 | 402 | 436 | 485 |
| 9L11HMA180S | 180 | 144 | 457 | 335 | 355 | 372 | 388 | 414 | 449 | 499 |
| 9L11HMA192S | 192 | 152 | 482 | 354 | 374 | 393 | 409 | 437 | 473 | 527 |
| 9L11HMA228S | 228 | 180 | 571 | 419 | 443 | 465 | 485 | 517 | 561 | 624 |
| 9L11HMA240S | 240 | 190 | 602 | 472 | 468 | 491 | 511 | 546 | 592 | 656 |
| 9L11HMA258S | 258 | 209 | 663 | 519 | 515 | 540 | 563 | 601 | 651 | 724 |
| 9L11HMA264S | 264 | 212 | 673 | 526 | 522 | 548 | 571 | 609 | 660 | 735 |
| 9L11HMA276S | 276 | 220 | 698 | 546 | 542 | 568 | 592 | 632 | 685 | 762 |
| 9L11HMA288S | 288 | 234 | 729 | 571 | 566 | 594 | 619 | 661 | 716 | 767 |
| 9L11HMA312S | 312 | 245 | 777 | 608 | 603 | 633 | 660 | 704 | 763 | 849 |
| 9L11HMA396S | 336 | 264 | 1009 | 790 | 783 | 821 | 856 | 914 | 991 | 1102 |
| 9L11HMA420S | 420 | 335 | 1063 | 832 | 825 | 865 | 902 | 963 | 1043 | 1161 |
| 9L11HMA444S | 444 | 353 | 1120 | 876 | 869 | 912 | 950 | 1014 | 1100 | 1223 |

Mechanical Characteristics — Four Hole NEMA - for Indoor or Outdoor Mounting

| STANDARD ARRESTER CATALOG NUMBER | DUTY CYCLE (kV) rms | MCOV (kV) rms | HEIGHT "X" | | SILICON Drawing | CREEPAGE DISTANCE | | INSULATION WITHSTAND DISTANCE | | | | | | | |
|----------------------------------|---------------------|---------------|------------|--------|-----------------|-------------------|---------|-------------------------------|--------|-----------------|--------|--------|-----|---------------|-------|
| | | | | | | | | PHASE TO PHASE | | PHASE TO GROUND | | WEIGHT | | RING DIAMETER | |
| | | | | | | | | in | mm | in | mm | in | mm | lbs | kg |
| 9L11HMA054S | 54 | 42 | 38.1 | 967.7 | 8 | 83 | 2108.2 | 15.6 | 396.2 | 10.9 | 276.9 | 104 | 47 | | |
| 9L11HMA060S | 60 | 48 | 38.1 | 967.7 | 8 | 83 | 2108.2 | 17.1 | 434.3 | 12.5 | 317.5 | 107 | 48 | | |
| 9L11HMA072S | 72 | 57 | 38.1 | 967.7 | 8 | 83 | 2108.2 | 19.5 | 495.3 | 14.8 | 375.9 | 112 | 51 | | |
| 9L11HMA090S | 90 | 70 | 44.4 | 1127.8 | 8 | 113 | 2870.2 | 26 | 660.4 | 18.2 | 462.3 | 125 | 57 | | |
| 9L11HMA090S | 90 | 74 | 44.4 | 1127.8 | 8 | 113 | 2870.2 | 27 | 685.8 | 19.2 | 487.7 | 128 | 58 | | |
| 9L11HMA096S | 96 | 76 | 44.4 | 1127.8 | 8 | 113 | 2870.2 | 27.5 | 698.5 | 19.8 | 502.9 | 130 | 59 | | |
| 9L11HMA108S | 108 | 84 | 52.1 | 1323.3 | 8 | 142 | 3606.8 | 31.2 | 792.5 | 21.8 | 553.7 | 141 | 64 | | |
| 9L11HMA108S | 108 | 88 | 52.1 | 1323.3 | 8 | 142 | 3606.8 | 32.2 | 817.9 | 22.9 | 581.7 | 144 | 65 | | |
| 9L11HMA120S | 120 | 98 | 52.1 | 1323.3 | 8 | 142 | 3606.8 | 36.4 | 924.6 | 25.5 | 647.7 | 149 | 68 | | |
| 9L11HMA132S | 132 | 106 | 58.8 | 1493.5 | 8 | 171 | 4343.4 | 38.4 | 975.4 | 27.6 | 701 | 167 | 76 | | |
| 9L11HMA144S | 144 | 115 | 58.8 | 1493.5 | 8 | 171 | 4343.4 | 40.8 | 1036.3 | 29.9 | 759.5 | 172 | 78 | | |
| 9L11HMA168S | 168 | 131 | 76.9 | 1953.3 | 8 | 196 | 4978.4 | 44.9 | 1440.5 | 34.1 | 866.1 | 231 | 105 | | |
| 9L11HMA172S | 172 | 140 | 76.9 | 1953.3 | 9 | 196 | 4978.4 | 77 | 1955.8 | 48.9 | 1242.1 | 257 | 116 | 25 | 635 |
| 9L11HMA180S | 180 | 144 | 76.9 | 1953.3 | 9 | 196 | 4978.4 | 78 | 1981.2 | 50 | 1270 | 257 | 116 | 25 | 635 |
| 9L11HMA192S | 192 | 152 | 83.2 | 2113.3 | 9 | 225 | 5715 | 80.1 | 2034.5 | 52 | 1320.8 | 262 | 119 | 25 | 635 |
| 9L11HMA228S | 228 | 180 | 90.9 | 2308.9 | 9 | 254 | 6451.6 | 87.4 | 2220 | 59.3 | 1506.2 | 291 | 132 | 25 | 635 |
| 9L11HMA240S | 240 | 190 | 98.6 | 2504.4 | 9 | 285 | 7239 | 90 | 2286 | 61.9 | 1572.3 | 317 | 144 | 25 | 635 |
| 9L11HMA258S | 258 | 209 | 105.3 | 2674.6 | 9 | 313 | 7950.2 | 116.6 | 2961.6 | 73.9 | 1877.1 | 330 | 150 | 39 | 990.6 |
| 9L11HMA264S | 264 | 212 | 105.3 | 2674.6 | 9 | 313 | 7950.2 | 117.4 | 2982 | 74.6 | 1894.8 | 349 | 180 | 39 | 990.6 |
| 9L11HMA276S | 276 | 220 | 105.3 | 2674.6 | 9 | 313 | 7950.2 | 119.5 | 3035.3 | 76.7 | 1948.2 | 351 | 159 | 39 | 990.6 |
| 9L11HMA288S | 288 | 230 | 112 | 2844.8 | 9 | 344 | 8737.6 | 122.1 | 3101.3 | 79.3 | 2014.2 | 360 | 163 | 39 | 990.6 |
| 9L11HMA312S | 312 | 245 | 129.7 | 3294.4 | 9 | 367 | 9321.8 | 126 | 3200.4 | 83.2 | 2113.3 | 406 | 184 | 39 | 990.6 |
| 9L11HMA396S | 336 | 264 | 151.8 | 3855.7 | 9 | 455 | 11557 | 178 | 4531.4 | 112.9 | 2867.7 | 532 | 241 | 80 | 2032 |
| 9L11HMA420S | 420 | 335 | 158.5 | 4025.9 | 9 | 484 | 12293.6 | 182.8 | 4643.1 | 117.3 | 2979.4 | 539 | 244 | 80 | 2032 |
| 9L11HMA444S | 444 | 353 | 165.2 | 4196.1 | 9 | 514 | 13055.6 | 187.5 | 4762.5 | 122 | 3098.8 | 564 | 256 | 80 | 2032 |

Drawing 8

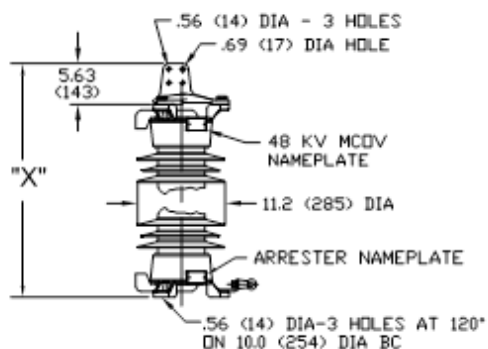

Drawing 9

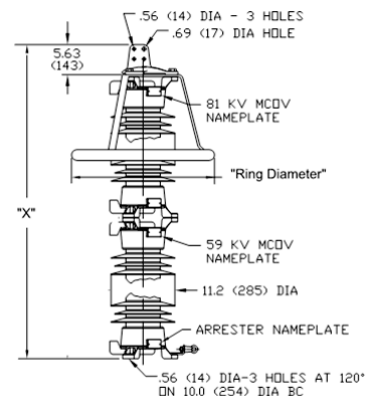

Electrical Characteristics

| GE VERNOVA | | | | | | MAXIMUM DISCHARGE VOLTAGE USING 8/20 CURRENT WAVE(kV) | | | | | |
|------------------|-------------|----------------------------|--|---|--|---|-------|-------|-------|-------|-------|
| # FOUR HOLE NEMA | # EYEBOLT | DUTY CYCLE RATING (kV) rms | MAXIMUM CONTINUOUS OPERATING VOLTAGE (MCOV) (kV) rms | MAXIMUM 0.5µs DISCHARGE VOLTAGE kV ⁽¹⁾ | MAXIMUM SWITCHING SURGE PROTECTIVE LEVEL kV ⁽²⁾ | 1.5 kA | 3 kA | 5 kA | 10 kA | 20 kA | 40 kA |
| 9L2PPA003S | 9L2PPB003S | 3 | 2.55 | 8.6 | 6.4 | 6.8 | 7.2 | 7.5 | 8.1 | 9 | 10.1 |
| 9L2PPA006S | 9L2PPB006S | 6 | 5.1 | 17.1 | 12.7 | 13.6 | 14.4 | 15 | 16.2 | 17.9 | 20.2 |
| 9L2PPA009S | 9L2PPB009S | 9 | 7.65 | 25.8 | 19.1 | 20.5 | 21.6 | 22.6 | 24.4 | 27 | 30.4 |
| 9L2PPA010S | 9L2PPB010S | 10 | 8.4 | 28.4 | 21.1 | 22.6 | 23.8 | 24.9 | 26.9 | 29.8 | 33.5 |
| 9L2PPA012S | 9L2PPB012S | 12 | 10.2 | 34.1 | 25.3 | 27.1 | 28.6 | 29.9 | 32.3 | 35.8 | 40.3 |
| 9L2PPA015S | 9L2PPB015S | 15 | 12.7 | 42.9 | 31.8 | 34.1 | 36 | 37.6 | 40.6 | 44.9 | 50.6 |
| 9L2PPA018S | 9L2PPB018S | 18 | 15.3 | 51.6 | 38.3 | 40.9 | 43.2 | 45.2 | 48.8 | 54 | 60.9 |
| 9L2PPA021S | 9L2PPB021S | 21 | 17 | 56.9 | 42.2 | 45.1 | 47.7 | 49.9 | 53.8 | 59.6 | 67.1 |
| 9L2PPA024AS | 9L2PPB024AS | 24 | 19.5 | 68.3 | 50.6 | 54.2 | 57.2 | 59.9 | 64.8 | 71.5 | 80.6 |
| 9L2PPA027S | 9L2PPB027S | 27 | 22 | 77.4 | 57.4 | 61.4 | 64.9 | 67.9 | 73.2 | 81 | 91.3 |
| 9L2PPA030S | 9L2PPB030S | 30 | 24.4 | 85.3 | 63.3 | 67.7 | 71.5 | 74.8 | 80.7 | 89.3 | 101 |
| 9L2PPA036AS | 9L2PPB036AS | 36 | 29 | 102 | 76 | 81.3 | 85.9 | 89.8 | 96.6 | 107 | 121 |
| 9L2PPA039S | 9L2PPB039S | 39 | 31.5 | 108.4 | 80.4 | 86.1 | 90.9 | 95.1 | 102.6 | 113.6 | 127.9 |
| 9L2PPA045AS | 9L2PPB045AS | 45 | 36.5 | 125.1 | 92.8 | 99.3 | 104.9 | 109.8 | 118.4 | 131.1 | 147.6 |
| 9L2PPA048AS | 9L2PPB048AS | 48 | 39 | 136.6 | 101.3 | 108.4 | 114.5 | 119.8 | 129.2 | 143 | 161.1 |
| 9L2PPA054AS | 9L2PPB054AS | 54 | 42 | 147.9 | 109.7 | 117.4 | 125 | 129.7 | 139.9 | 154.9 | 174.5 |
| 9L2PPA060AS | 9L2PPB060AS | 60 | 48 | 165 | 122.4 | 131 | 138.3 | 144.7 | 156.1 | 172.8 | 195 |
| 9L2PPA072AS | 9L2PPB072AS | 72 | 57 | 199 | 147.7 | 158.1 | 166.9 | 174.6 | 188.4 | 209 | 235 |
| 9L2PPA090S | 9L2PPB090S | 90 | 70 | 250 | 185.7 | 198.7 | 209.8 | 219.5 | 236.8 | 262 | 295 |
| 9L2PPA096S | 9L2PPB096S | 96 | 76 | 261.7 | 194.1 | 207.7 | 219.4 | 229.5 | 247.6 | 274.1 | 308.8 |
| CONTACT FACTORY | | 108 | 84 | 296 | 219.5 | 234.9 | 248.1 | 259.6 | 280 | 310 | 349.2 |
| 9L2PPA108S | 9L2PPB108S | 108 | 88 | 296 | 219.5 | 234.9 | 248.1 | 259.6 | 280 | 310 | 349.2 |
| 9L2PPA120S | 9L2PPB120S | 120 | 98 | 327.7 | 243 | 26.1 | 274.7 | 287.4 | 310 | 343.2 | 386.6 |
| 9L2PPA132S | 9L2PPB132S | 132 | 106 | 375.2 | 278.3 | 297.8 | 314.5 | 329.1 | 355 | 393 | 443 |
| 9L2PPA144S | 9L2PPB144S | 144 | 115 | 392 | 290.9 | 311.3 | 328.7 | 343.9 | 371 | 411 | 463 |

Electrical Characteristics

| FOUR HOLE NEMA | DUTY CYCLE (kV) rms | MCOV (kV) rms | DRAWING NUMBER | HEIGHT "X" | | LEAKAGE | | PHASE-TO-PHASE | | PHASE -TO-GROUND | | WEIGHT | |
|----------------|---------------------|---------------|----------------|------------|--------|---------|--------|----------------|--------|------------------|--------|--------|------|
| | | | | in | mm | in | mm | in | mm | in | mm | lbs | kg |
| 9L2PPA003S | 3 | 2.55 | 1 | 6.8 | 172.7 | 15.4 | 391.2 | 4.4 | 111.8 | 3.3 | 83.8 | 6.2 | 2.8 |
| 9L2PPA006S | 6 | 5.1 | 1 | 6.8 | 172.7 | 15.4 | 391.2 | 4.6 | 116.8 | 3.2 | 81.3 | 6.2 | 2.8 |
| 9L2PPA009S | 9 | 7.65 | 1 | 6.8 | 172.7 | 15.4 | 391.2 | 4.7 | 119.4 | 3.3 | 83.8 | 6.2 | 2.8 |
| 9L2PPA010S | 10 | 8.4 | 1 | 6.8 | 172.7 | 15.4 | 391.2 | 4.9 | 124.5 | 3.5 | 88.9 | 6.2 | 2.8 |
| 9L2PPA012S | 12 | 10.2 | 1 | 6.8 | 172.7 | 15.4 | 391.2 | 4.9 | 124.5 | 3.5 | 88.9 | 6.2 | 2.8 |
| 9L2PPA015S | 15 | 12.7 | 1 | 12.2 | 309.9 | 30.8 | 782.3 | 6.2 | 157.5 | 4.8 | 121.9 | 10 | 4.5 |
| 9L2PPA018S | 18 | 15.3 | 1 | 12.2 | 309.9 | 30.8 | 782.3 | 6.6 | 167.6 | 5.2 | 132.1 | 10 | 4.5 |
| 9L2PPA021S | 21 | 17 | 1 | 12.2 | 309.9 | 30.8 | 782.3 | 7.6 | 193.0 | 6.2 | 157.5 | 10 | 4.5 |
| 9L2PPA024AS | 24 | 19.5 | 1 | 12.2 | 309.9 | 30.8 | 782.3 | 7.6 | 193.0 | 6.2 | 157.5 | 10 | 4.5 |
| 9L2PPA027S | 27 | 22 | 1 | 17.6 | 447.0 | 46.2 | 1173.5 | 9.6 | 243.8 | 8.2 | 208.3 | 13.5 | 6.1 |
| 9L2PPA030S | 30 | 24.4 | 1 | 17.6 | 447.0 | 46.2 | 1173.5 | 9.8 | 248.9 | 8.4 | 213.4 | 13.5 | 6.1 |
| 9L2PPA036AS | 36 | 29 | 1 | 17.6 | 447.0 | 46.2 | 1173.5 | 9.8 | 248.9 | 8.4 | 213.4 | 13.5 | 6.1 |
| 9L2PPA039S | 39 | 31.5 | 1 | 23.0 | 584.2 | 61.6 | 1564.6 | 12.8 | 325.1 | 11.4 | 289.6 | 17 | 7.7 |
| 9L2PPA045AS | 45 | 36.5 | 1 | 23.0 | 584.2 | 61.6 | 1564.6 | 12.8 | 325.1 | 11.4 | 289.6 | 17 | 7.7 |
| 9L2PPA048AS | 48 | 39 | 1 | 23.0 | 584.2 | 61.6 | 1564.6 | 12.8 | 325.1 | 11.4 | 289.6 | 17 | 7.7 |
| 9L2PPA054AS | 54 | 42 | 1 | 28.4 | 721.4 | 77.0 | 1955.8 | 15.8 | 401.3 | 14.4 | 365.8 | 19.6 | 8.9 |
| 9L2PPA060AS | 60 | 48 | 1 | 28.4 | 721.4 | 77.0 | 1955.8 | 15.8 | 401.3 | 14.4 | 365.8 | 19.6 | 8.9 |
| 9L2PPA072AS | 72 | 57 | 1 | 33.8 | 858.5 | 92.4 | 2347.0 | 19.8 | 502.9 | 18.4 | 467.4 | 23.1 | 10.5 |
| 9L2PPA090S | 90 | 70 | 1A | 44.0 | 1117.6 | 109.0 | 2768.6 | 40.0 | 1016.0 | 33.0 | 838.2 | 52 | 23.6 |
| 9L2PPA096S | 96 | 76 | 1A | 44.0 | 1117.6 | 109.0 | 2768.6 | 42.0 | 1066.8 | 35.0 | 889.0 | 53 | 24.1 |
| 9L2PPA108S | 108 | 88 | 1A | 44.0 | 1117.6 | 109.0 | 2768.6 | 46.0 | 1168.4 | 39.0 | 990.0 | 54 | 24.5 |
| 9L2PPA120S | 120 | 98 | 1A | 66.5 | 1689.1 | 162.0 | 4114.8 | 51.0 | 1295.4 | 44.0 | 1117.6 | 67.5 | 30.7 |
| 9L2PPA132S | 132 | 106 | 1A | 66.5 | 1689.1 | 162.0 | 4114.8 | 55.0 | 1397.0 | 47.0 | 1193.8 | 67.5 | 30.7 |
| 9L2PPA144S | 144 | 115 | 1A | 66.5 | 1689.1 | 162.0 | 4114.8 | 58.0 | 1473.2 | 50.0 | 1270.0 | 67.5 | 30.7 |

4 Hole Nema — Drawing 1

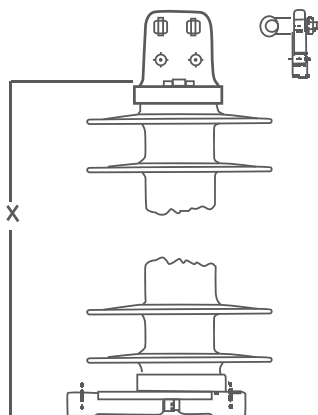

4 Hole Nema — Drawing 1A

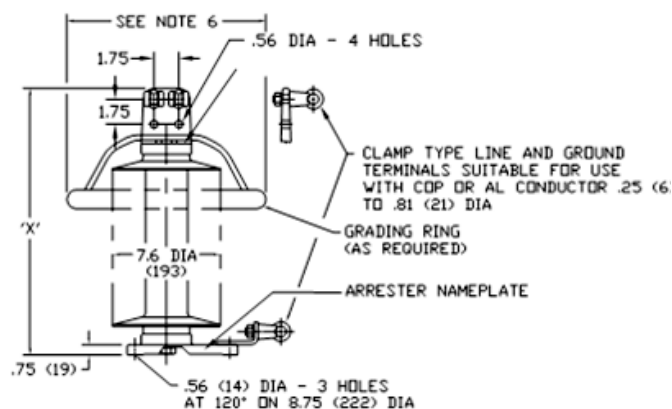

Mechanical Characteristics — Eyebolt - for Indoor or Outdoor Upright Mounting

| EYEBOLT TERMINAL | DUTY CYCLE (kV) rms | MCOV (kV) rms | DRAWING NUMBER | HEIGHT "X" | | LEAKAGE | | PHASE-TO-PHASE | | PHASE-TO-GROUND | | WEIGHT | |
|------------------|---------------------|---------------|----------------|------------|--------|---------|--------|----------------|--------|-----------------|--------|--------|------|
| | | | | in | mm | in | mm | in | mm | in | mm | lbs | kg |
| 9L2PPB003S | 3 | 2.55 | 2 | 6.8 | 172.7 | 15.4 | 391.2 | 4.4 | 111.8 | 3.3 | 83.8 | 6.2 | 2.8 |
| 9L2PPB006S | 6 | 5.1 | 2 | 6.8 | 172.7 | 15.4 | 391.2 | 4.6 | 116.8 | 3.2 | 81.3 | 6.2 | 2.8 |
| 9L2PPB009S | 9 | 7.65 | 2 | 6.8 | 172.7 | 15.4 | 391.2 | 4.7 | 119.4 | 3.3 | 83.8 | 6.2 | 2.8 |
| 9L2PPB010S | 10 | 8.4 | 2 | 6.8 | 172.7 | 15.4 | 391.2 | 4.9 | 124.5 | 3.5 | 88.9 | 6.2 | 2.8 |
| 9L2PPB012S | 12 | 10.2 | 2 | 6.8 | 172.7 | 15.4 | 391.2 | 4.9 | 124.5 | 3.5 | 88.9 | 6.2 | 2.8 |
| 9L2PPB015S | 15 | 12.7 | 2 | 12.2 | 309.9 | 30.8 | 782.3 | 6.2 | 157.5 | 4.8 | 121.9 | 10 | 4.5 |
| 9L2PPB018S | 18 | 15.3 | 2 | 12.2 | 309.9 | 30.8 | 782.3 | 6.6 | 167.6 | 5.2 | 132.1 | 10 | 4.5 |
| 9L2PPB021S | 21 | 17 | 2 | 12.2 | 309.9 | 30.8 | 782.3 | 7.6 | 193.0 | 6.2 | 157.5 | 10 | 4.5 |
| 9L2PPB024AS | 24 | 19.5 | 2 | 12.2 | 309.9 | 30.8 | 782.3 | 7.6 | 193.0 | 6.2 | 157.5 | 10 | 4.5 |
| 9L2PPB027S | 27 | 22 | 2 | 17.6 | 447.0 | 46.2 | 1173.5 | 9.6 | 243.8 | 8.2 | 208.3 | 13.5 | 6.1 |
| 9L2PPB030S | 30 | 24.4 | 2 | 17.6 | 447.0 | 46.2 | 1173.5 | 9.8 | 248.9 | 8.4 | 213.4 | 13.5 | 6.1 |
| 9L2PPB036AS | 36 | 29 | 2 | 17.6 | 447.0 | 46.2 | 1173.5 | 9.8 | 248.9 | 8.4 | 213.4 | 13.5 | 6.1 |
| 9L2PPB039S | 39 | 31.5 | 2 | 23.0 | 584.2 | 61.6 | 1564.6 | 12.8 | 325.1 | 11.4 | 289.6 | 17 | 7.7 |
| 9L2PPB045AS | 45 | 36.5 | 2 | 23.0 | 584.2 | 61.6 | 1564.6 | 12.8 | 325.1 | 11.4 | 289.6 | 17 | 7.7 |
| 9L2PPB048AS | 48 | 39 | 2 | 23.0 | 584.2 | 61.6 | 1564.6 | 12.8 | 325.1 | 11.4 | 289.6 | 17 | 7.7 |
| 9L2PPB054AS | 54 | 42 | 2 | 28.4 | 721.4 | 77.0 | 1955.8 | 15.8 | 401.3 | 14.4 | 365.8 | 19.6 | 8.9 |
| 9L2PPB060AS | 60 | 48 | 2 | 28.4 | 721.4 | 77.0 | 1955.8 | 15.8 | 401.3 | 14.4 | 365.8 | 19.6 | 8.9 |
| 9L2PPB072AS | 72 | 57 | 2 | 33.8 | 858.5 | 92.4 | 2347.0 | 19.8 | 502.9 | 18.4 | 467.4 | 23.1 | 10.5 |
| 9L2PPB090S | 90 | 70 | 2A | 44.0 | 1117.6 | 109.0 | 2768.6 | 40.0 | 1016.0 | 33.0 | 838.2 | 52 | 23.6 |
| 9L2PPB096S | 96 | 76 | 2A | 44.0 | 1117.6 | 109.0 | 2768.6 | 42.0 | 1066.8 | 35.0 | 889.0 | 53 | 24.1 |
| 9L2PPB108S | 108 | 88 | 2A | 44.0 | 1117.6 | 109.0 | 2768.6 | 46.0 | 1168.4 | 39.0 | 990.0 | 54 | 24.5 |
| 9L2PPB120S | 120 | 98 | 2A | 66.5 | 1689.1 | 162.0 | 4114.8 | 51.0 | 1295.4 | 44.0 | 1117.6 | 67.5 | 30.7 |
| 9L2PPB132S | 132 | 106 | 2A | 66.5 | 1689.1 | 162.0 | 4114.8 | 55.0 | 1397.0 | 47.0 | 1193.8 | 67.5 | 30.7 |
| 9L2PPB144S | 144 | 115 | 2A | 66.5 | 1689.1 | 162.0 | 4114.8 | 58.0 | 1473.2 | 50.0 | 1270.0 | 67.5 | 30.7 |

Eyebolt Terminal — Drawing 2

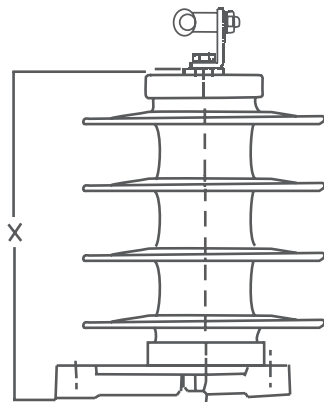

Eyebolt Terminal — Drawing 2A

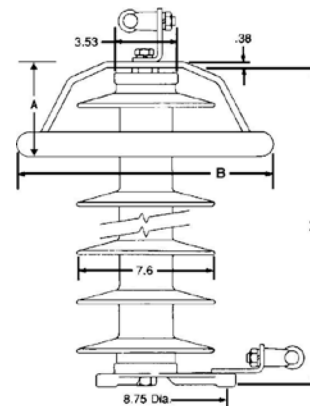

For more information, visit governova.com/grid-solutions



© 2025 GE Vernova and/or its affiliates. All rights reserved. GE and the GE Monogram are trademarks of General Electric Company used under trademark license.

GEA-33298-(E)
English
250811