

GE VERNOVA TRANQUELL™ SURGE ARRESTERS

Product Selection & Application Guide



Polymer/Porcelain Station & Polymer
Intermediate Class Arresters
New 2013 GE Vernova AS Station Class Product Line:
IEEE®/ANSI® C62.11

Product Description

The GE Vernova TRANQUELL line of surge arrester products provide excellent protective characteristics, temporary over voltage capability, and switching surge energy withstand to power systems.

GE Vernova arresters are ideally suited for application in both indoor and outdoor situations. They are designed and manufactured in accordance with the latest revision of ANSI/IEEE C62.11.

GE Vernova Surge Protection

The performance and reliability of today's electric power system can be enhanced with the unique characteristics of GE Vernova TRANQUELL arrester products. Since introducing the world's first metal oxide arrester in 1976, offering new concepts in surge arrester design and application, GE Vernova has developed and applied metal oxide technology for a variety of traditional and special applications. GE Vernova offers an extensive line of surge arrester products. From distribution class to EHV arresters up to 612kV rating as well as high energy varistors for series capacitor applications.

Product and power systems engineers work closely to optimize product performance on the system. This tradition has made GE Vernova one of the world's leading suppliers of metal oxide arresters and specialty varistors.

Station Arresters are designed and manufactured in accordance with the latest revision of ANSI/IEEE C62.11. GE Vernova TRANQUELL polymer and porcelain arresters are designed to meet the most demanding service conditions.

The new AS series of Porcelain Station Class Arrester is our replacement for the standard product line ratings (54 kV and above).

The Intermediate Polymer Arresters remain unchanged.



Table of Contents

Introduction	3
Arrester Rating Selection Application Guide	4
TOV Curves	6
Arrester Service Conditions and Other Considerations	6
Insulation Coordination	8
Cantilever Strength	9
Arrester Detailed Specifications:	
Polymer Station Class Arrester	10
Porcelain Station Class Arrester	14
Silicon Station Class Arrester	19
Polymer Intermediate Class Arrester	21

TRANQUELL arresters provide exceptional overvoltage protection of major power system equipment. Under normal system conditions, the arrester appears as a high impedance path. When a surge reaches the arrester, the arrester changes to a low impedance path and conducts only the current necessary to limit the overvoltage.

As a result, TRANQUELL arresters absorb minimum energy to protect equipment insulation.

Arrester Construction

Metal Oxide Disks

The core operating component of a modern Lightning arrester is the Metal oxide varistor element. As a leader in MOV formulation and their use in a Gapless construction design, all classes of GE Vernova arresters the same quality MOV.

Classes of ANSI/IEEE C62.11 Arresters

GE Vernova TRANQUELL arresters are offered in all classes:

Porcelain and Polymer Station Class, Polymer Intermediate Class, Polymer Distribution Class and Riser Pole.

Porcelain Surge Arresters

GE Vernova TRANQUELL Porcelain surge arresters have been the industry standard for decades. Porcelain models cover Voltage ratings from 3kV to 612kV. GE Vernova TRANQUELL Porcelain EHV (Extra High Voltage) Arresters cover ratings above 420kV.

With unrivaled mechanical strength, and an altitude rating to 12,000 feet ASL (3,600 M ASL) GE Vernova TRANQUELL Porcelain models fill the most demanding applications. Tested in accordance with IEEE 693, most models meet the High Seismic Performance level.

Porcelain EHV Arrester

GE Vernova TRANQUELL EHV arresters incorporate a heat transfer system utilizing silicone-rubber material wedged between the metal oxide disk and internal porcelain wall. Heat generated in the valve element from steady state, temporary, or transient conditions is transferred through the silicone- rubber material to the porcelain housing and then dissipated to the outside environment.

**GE Vernova TRANQUELL
arresters are designed and tested
in accordance with
ANSI/IEEE C62.11 standards**

Polymer Surge Arresters

GE Vernova TRANQUELL polymer surge arresters are constructed utilizing a rugged field-proven silicone alloy EPDM housing. Polymer models cover Voltage ratings from 3kV to 228kV. GE Vernova TRANQUELL polymer arresters offer exceptional electrical characteristics such as low protective levels, high energy handling capability, and improved TOV capability. The electrical performance of the polymer arresters is enhanced by its ability to easily transfer heat from the metal oxide elements to the outside environment. These light weight non-shattering design, fit both 8.75" and 10" mounting patterns.

Arrester Testing ANSI/IEEE C62.11

GE Vernova TRANQUELL arresters comply with the design tests outlined in ANSI/IEEE C62.11. At minimum the IEEE C62.11 clauses below are tested to, and met.

- Insulation Withstand
- Discharge Voltage
- Disc Accelerated Aging
- Contamination
- RIV
- High Current, Short Duration
- Transmission Line Discharge
- Duty Cycle
- Temporary Overvoltage
- Short Circuit
- Ultimate Mechanical Strength-Static
- Partial Discharge

In addition, factory tests are performed on each metal oxide disk. Long- term stability tests are conducted on each and optimized. Every disk is subjected to an impulse current of 10kA 8/20ms to measure its discharge voltage or nominal protective level. A disk strength test series, consisting of multiple transmission-line discharges, is performed to make certain that the disk has full energy capability.

Arrester Rating Selection Application Guide

The objective of arrester application is to select the lowest rated surge arrester that will have a satisfactory service life on the power system while providing adequate protection of equipment insulation. An arrester of the minimum practical rating is generally preferred because it provides the greatest margin of protection for the insulation. The use of a higher rating increases the capability of the arrester to survive on the power system, but reduces the margin of protection it provides for a specific insulation level. Thus, arrester selection must strike a balance between arrester survival and equipment protection.

Table 1 lists arrester ratings that would normally be applied on systems of various line-to-line voltages. The rating of the arrester is defined as the rms voltage at which the arrester passes the duty-cycle test as defined by the referenced standard. To decide which rating is most appropriate for a particular application,

consideration must be given to the following system stresses to which the arrester will be exposed:

- Continuous system voltage
- Temporary overvoltage
- Switching surges (frequently a consideration in systems of 345kV and above, and for capacitor banks and cable applications)
- Lightning surges

The arrester selected must have sufficient capability to meet the anticipated service requirements in all categories.

For effectively grounded neutral systems, TRANQUELL arresters with MCOV equal to the maximum line-to-neutral kV is the normal application. As an example, a 230kV system usually has a maximum line-to-line continuous voltage of 242 kV line-to-ground voltage.

Table 1A — Typical Arrester Ratings for System Voltages

ARRESTER RATING (kV) rms	MCOV ¹ CAPABILITY (L-N) (kV) rms		NORMALLY USED ON SYSTEM VOLTAGE CLASS (L-L)	
	Porcelain	Polymer	HIGH IMPEDANCE ² GROUNDED, UNGROUNDED (DELTA) OR TEMPORARILY UNGROUNDED CIRCUITS	SOLIDLY GROUNDED NEUTRAL (kV) rms
3	2.55	2.55	2.4	4.16
6	5.1	5.1	4.8	4.8
9	7.65	7.65	6.9	12.47
10	8.4	8.4	8.32	13.8
12	10.2	10.2	12	--
15	12.7	12.7	13.8 ²	20.78
18	15.3	15.3	13.8	24.94
21	17	17	--	24.94
24	19.5	19.5	23 ²	--
27	22	22	23	34.5
30	24.4	24.4	24.94	34.5
36	29	29	34.5 ²	--
39	31.5	31.5	34.5 ²	--
45	36.5	36.5	34.5	--
48	39	39	46 ²	--
54	42	42	--	69
60	48	48	46	69
66	53	53	46	--
72	57	57	69 ²	--
90	74	70	69	115
96	76	76	--	115
108	84	84	--	138
108	88	88	--	138
120	98	98	115 ²	161
132	106	106	--	161

Table 1B — Typical Arrester Ratings for System Voltages

ARRESTER RATING (kV) rms	MCOV CAPABILITY (L-N) (kV) rms		NORMALLY USED ON SYSTEM VOLTAGE CLASS (L-L)	
	Porcelain	Polymer	HIGH IMPEDANCE ² GROUNDED, UNGROUNDED (DELTA) OR TEMPORARILY UNGROUNDED CIRCUITS	SOLIDLY GROUNDED NEUTRAL (kV) rms
144	115	115	138 ²	161
168	131	131	138	--
172	140	140	161 ²	230
180	144	144	--	230
192	152	152	161	230
228	180	180	--	--
240	194	194	--	--
258	209		FOR NOMINAL 345kV SYSTEMS	
264	212		FOR NOMINAL 345kV SYSTEMS	
276	220		FOR NOMINAL 345kV SYSTEMS	
288	234		FOR NOMINAL 345kV SYSTEMS	
294	237		FOR NOMINAL 345kV SYSTEMS	
300	243		FOR NOMINAL 345kV SYSTEMS	
312	245		FOR NOMINAL 400kV SYSTEMS	
336	264		FOR NOMINAL 400kV SYSTEMS	
360	288		FOR NOMINAL 400kV SYSTEMS	
396	318		FOR NOMINAL 500kV SYSTEMS	
420	335		FOR NOMINAL 500kV SYSTEMS	
396	318		FOR NOMINAL 500kV SYSTEMS ³	
420	335		FOR NOMINAL 500kV SYSTEMS ³	
444	353		FOR NOMINAL 500kV SYSTEMS ³	
588	470		FOR NOMINAL 765kV SYSTEMS ³	
612	485		FOR NOMINAL 765kV SYSTEMS ³	

¹ TRANQUELL Arresters are designed to be operated at voltages equal to or less than their continuous capability as stated in MCOV column 2.

² Based on our recommended MCOV ratings for normal system voltages, for systems with ground faults lasting no more than 30 minutes.

³ Use Extra High Voltage (EHV) 9L16GNS series; see page 14 for details.

Maximum Continuous Operating Voltage

Arresters in service are continually exposed to system operating voltage. For each arrester rating, there is a recommended limit to the magnitude of voltage which may be continuously applied. This has been termed the Maximum Continuous Operating Voltage (MCOV) of the arrester. These values meet or exceed those values contained in the referenced standard. The arrester rating must be selected such that the maximum continuous power system voltage applied to the arrester is less than, or equal to, the arrester's continuous voltage capability. Attention must be given to both the circuit connection (single phase, wye or delta) and the arrester connection (line-to-ground, line-to-line). In most cases, the arrester is connected line-to-ground and therefore must withstand line-to-ground system operating voltage. If an arrester is to be connected line-to-line, phase-to-phase voltage must be considered. In addition, attention should be given to an arrester application on the delta tertiary winding of a transformer where one corner of the delta is permanently grounded. In such circuits, the normal voltage continuously applied to the arrester will be the full phase-to-phase voltage even though the arresters are connected line-to-ground.

Temporary Overvoltage

Temporary overvoltage (TOV) can be caused by a number of system events such as line-to-ground faults, circuit backfeeding, load rejection and ferroresonance. The system configuration and operating practices should be reviewed to identify the most probable forms of temporary overvoltage which may occur at the arrester location.

The primary effect of temporary overvoltages on metal oxide arresters is increased current and power dissipation, and a rising arrester temperature. TOV figures on page 6 show the temporary overvoltage capability of GE Vernova arrester designs. This figure defines the duration and magnitude of temporary overvoltage that may be applied to the arrester before the arrester voltage must be reduced to the arresters' continuous operating voltage capability. These capabilities have been defined independent of system impedance and are therefore valid for voltages applied at the arrester location.

Table 2 — Energy Capability

ARRESTER RATED VOLTAGE (kV) rms	HOUSING TYPE	ARRESTER TYPE	kJ/kV OF MCOV	PRODUCT SERIES
3 - 144kV	Polymer	Intermediate	6	9L12 series
2 - 57kV	Polymer	Station	6	9L11XPM/N/T series
3 - 228kV	Polymer	Station	9	9L11XPA/B/E series
3 - 48kV	Porcelain	Station	9	9L11ZGA/B series
54 - 420kV	Porcelain	Station	13	9L11ZTA series
54 - 420kV	Silicon	Station	13	9L11HMA (Rigid Hollow core)

Table 3 — Pressure Relief

ARRESTER TYPE	ARRESTER SERIES	PRESSURE RELIEF CAPABILITY-SYMMETRICAL rms kA	
		ANSI STANDARD C62.11 MINIMUM	PRODUCT DEMONSTRATED VALUES
Porcelain Station-Porcelain top *	9L11ZGB	None	10
Porcelain Station-Metal top *	9L11ZGA	40-65	65
Porcelain Station-Metal top *	9L11ZTA	40-65	65
Silicone Station-Metal top, rigid core **	9L11HMA	40-65	65
Polymer Station-4 hole NEMA or eyebolt **	9L11XPA/XPB	40-65	63
Polymer Station-4 hole NEMA or eyebolt ** (compact designs)	9L11XPN/XPT/XPM	40-65	40
Polymer Intermediate -4 hole NEMA or eyebolt **	9L12PPA/PPB	16.1	40
Polymer Intermediate-eyebolt **	9L12PPM/N/T	16.1	16.1

* Rating for initial venting only

** Polymer arrestors will survive multiple venting events

TOV Curves for AS Porcelain and Polymer Station and Intermediate Class Arresters

Figure 1A

TOV Curves for
9L11ZxxxxAS
Series Porcelain
Station Class Arresters

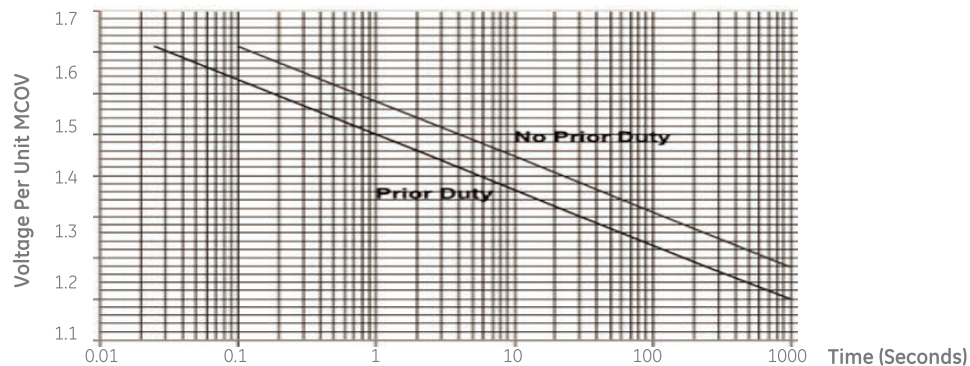

Figure 1B

TOV Curves for 9L11XPxxxxAS
Series Polymer
Station Class Arresters

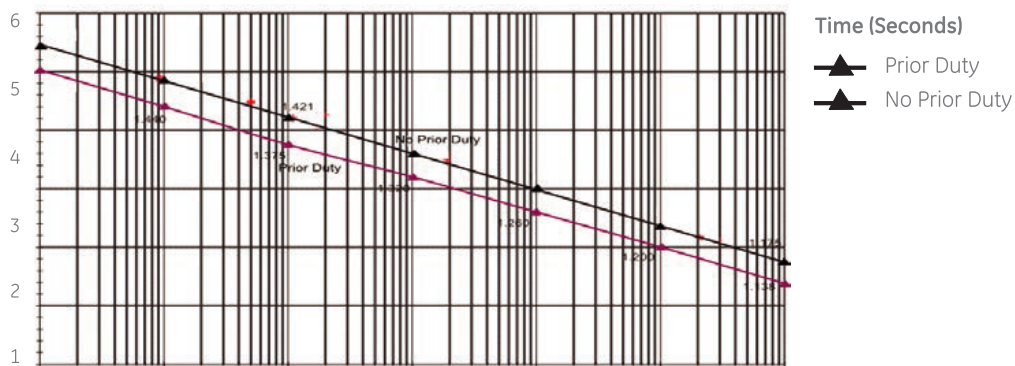
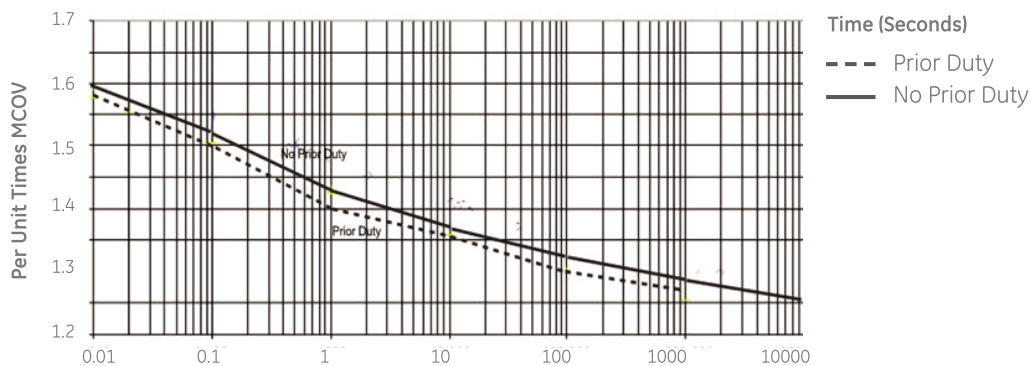

Figure 1C

TOV Curves for
9L12 Series
Intermediate
Class Arresters,
72kV Rated and Below



Service Conditions and Other Considerations

Arrester Contamination

GE Vernova TRANQUELL arresters are built in accordance with contamination tests outlined in ANSI/IEEE C62.11. More demanding tests than those outlined in the ANSI/IEEE C62.11 have shown that TRANQUELL arresters have outstanding capability to withstand the effects of very severe external contamination.

In applications where severe contamination is anticipated and extra leakage (creepage) distance is required for other station insulation, the arrester leakage distance should be reviewed. An arrester connected line-to-ground needs to have a leakage distance no greater than that required for the other line-to-ground insulation in the station. Extra leakage distance arrester housings are available. Manual hot washing of TRANQUELL arresters with a single stream of pressurized, de-ionized water is permissible, provided electric utility industry accepted safety precautions are observed.

Arrester Failure & Pressure Relief

In the event that the capability of a TRANQUELL arrester is exceeded, the metal oxide disks may crack or puncture. Such damage will reduce the arrester internal electrical resistance. Although this will limit the arrester's ability to survive future system conditions, it does not jeopardize the insulation protection provided by the arrester.

In the unlikely case of complete failure of the arrester, a line-to-ground arc will develop and pressure will build up inside the housing. This pressure will be safely vented to the outside and an external arc will be established provided the fault current is within the pressure relief fault current capability of the arrester. This low-voltage arc maintains equipment protection. All ratings of metal top porcelain station arresters will withstand a system available short circuit current of at least 65,000 amperes rms, symmetrical (169,000 amperes, first crest) in accordance with the test procedures outlined in ANSI/IEEE C62.11. Porcelain Pressure relief/fault current capability for all GE Vernova TRANQUELL arresters is shown in Table 3.

Once an arrester has safely vented, it no longer possesses its pressure relief/fault current capability. An arrester that has vented should be replaced immediately.

For a given application, the arrester to be selected should have a pressure relief/fault current capability greater than the maximum short-circuit current available at the intended arrester location including appropriate allowances for system growth. As with any porcelain arrester, the pressure relief apertures should be oriented away from adjacent apparatus to minimize damage to that apparatus in case of a pressure relief operation.

Ambient Temperature

Ambient temperature is an important consideration in the application of metal oxide arresters. Metal oxide materials exhibit a temperature dependent loss characteristic; the higher the ambient temperature, the higher will be the disk temperature when the arrester is operated at its continuous voltage capability.

The referenced standards indicate that the ambient temperature not exceeding 40°C is the standard service condition for arresters.

Altitude

TRANQUELL arresters are designed for altitudes up to 6,000 ft. (1800 m) above sea level, depending upon the specific model arrester. For higher altitude applications, extra clearances may be required in the design of the arrester housing. Contact GE Vernova for special design considerations and de-rating.

Mounting Considerations

TRANQUELL arresters are designed to be self-supporting for base mounting in a vertical position. However, units for other mounting arrangements are available on request. Arresters may be horizontally mounted if the cantilever loading, including arrester weight, icing, and terminal loads, does not exceed the maximum working cantilever strength. Pressure relief vents should be oriented to minimize damage to adjacent equipment by incandescent gases in the unlikely event of an arrester failure.

The rated working cantilever strengths for various arrester ratings are shown in the physical characteristics tables under the cantilever strength columns and are defined in accordance with ANSI C29.9 [8]. The defined strengths exceed the requirements for US Seismic Zone 3 (< 0.2g). For arresters installed in higher zones, seismic requirements need to be specified.

In the installation of arresters, recommended clearances between the arrester and any adjacent equipment must be observed. Failure to do so may result in unwanted flashovers and electrical overstress to internal arrester elements.

TRANQUELL arresters are designed to have a uniform voltage gradient along the length of the porcelain column. Where applicable, a grading ring is mounted on top of the arrester to establish a more uniform voltage distribution along the arrester. Clearly, if the arrester were mounted adjacent to a ground plane, this uniformity would be disturbed. To avoid such a situation, the minimum clearances to ground planes and other phase conductors must be observed.

Field Testing

In general, it is impractical to fully test an arrester in the field without high-voltage test equipment and accurate instrumentation. Instead, the arrester leakage current can be used to monitor the over-all state or condition of the arrester. For example, an abnormal leakage current measurement can be indicative of a wet surface-contaminated, or vented arrester.

Arrester leakage current can be monitored by a surge-counter leakage meter or by an oscilloscope connected directly to a surge counter test connection. Typical arrester leakage currents of station arresters operating at their continuous voltage capability and at 20°C are in the range of one-half to three milliamperes. Contamination of the arrester housing will contribute another component to the leakage current. If leakage current is to be used as an indication of arrester condition, the arrester must be clean, and the voltage and temperature must correspond to some standard test conditions, specific to each arrester location.

Arrester Selection Summary

The arrester selection process should include a review of all system stresses and service conditions expected at the arrester location. System stresses include continuous operating voltage, temporary overvoltage, and switching surges. If arresters of different ratings are required to meet these individual criteria, the highest resulting rating must be chosen. The arresters' capability for contamination, pressure relief, ambient temperature, and altitude must exceed the specified requirements.

Insulation Coordination

Once an arrester has been selected, the protection it provides to the equipment insulation can be determined. This protection is dependent on the protective characteristics of the arrester, the lightning and switching surges expected on the system, and the insulation characteristics of the protected equipment. It is quantified in terms of the protective ratio which is the ratio of the equipment insulation withstand to the arrester protective level. The objective is to meet or exceed the minimum protective ratios for the various classes of voltage surges as recommended in the application standards.

Arrester Protective Characteristics

The protective characteristic of GE Vernova TRANQUELL arresters is solely defined by the discharge voltage and is generally proportional to arrester MCOV. For any one arrester, the discharge voltage is a function of the magnitude of the arrester current and, in the impulse region, of the time to crest of the arrester current. In general, for any specific applied impulse current through the arrester, the time-to-crest for the voltage wave will be less than the time-to-crest for the current wave. Figure 2 shows the test results of a 10kA 8/20 μ s current impulse test.

GE Vernova TRANQUELL protective characteristics have been defined for fast impulse currents with times-to-crest shorter than 8 μ s. Available data on lightning strokes and simulation studies on impulse transients within substations both indicate that arresters in service may be subjected to fast current impulse waves. To illustrate arrester protection for slower transients, the discharge voltages have been defined for standard switching surge currents.

The arrester protective characteristic is a continuous function defined over a range of discharge currents and their resultant discharge voltages. The insulation withstand of equipment on the other hand, is generally defined only at three voltage points through the use of the standard switching surge, the full wave, and the chopped wave tests. To facilitate comparison with these three withstands, three corresponding protective levels of the GE Vernova TRANQUELL arrester have been selected as indicated in Table 4, page 9.

Three protective levels are selected for coordination with the transformer insulation characteristics. They are described as follows:

- **Switching Surge Protective Level:** This is the crest discharge voltage that results when a 36/90 μ s current impulse is applied to the arrester. To define the arrester's switching surge protective level, a "switching surge coordination current" is defined for the various system voltages. These currents are: 500 amperes for maximum system line-to-line voltages to 150kV, 1000 amperes for systems 151 to 325kV, and 2000 amperes for systems above 325kV.
- **Impulse Protective Level:** This is the crest discharge voltage that results when an 8/20 μ s current impulse is applied to the arrester. The resultant crest voltages for a variety of crest currents are given in the applicable Arrester Characteristics Table. To allow coordination with transformer insulation, a specific current impulse magnitude must be selected based on the system voltage.

- **Front-of-Wave Protective Level :** This is the discharge voltage for current impulses having a faster time to crest than the 8/20 μ s current impulse. This resultant crest voltage is listed as the front-of-wave (FOW) protective level. This protective level is derived by applying a series of current wave impulses to an arrester with varying times to crest (1, 2, 8 ms) and extending the measured voltages to 0.5 μ s in accordance with ANSI/IEEE C62.11.

In many cases, the calculated protective ratios exceed the minimum protective ratios recommended by ANSI by a considerable amount in actual power system applications.

As a specific example in protective ratio calculation, consider a 550kV BIL transformer protected by a 144kV rated GE Vernova TRANQUELL polymer station surge arrester. The three transformer insulation withstand voltages are as specified in ANSI C57.12.00[9]. The calculated ratios indicate that the arrester would provide excellent protection for the transformer insulation.

If the separation distance between the transformer and arrester is not negligible, the transformer voltage can oscillate above the arrester voltage during lightning transients, thus reducing the protective ratio. Guidance in estimating these effects can be obtained from ANSI C62.22. When making such transformer voltage estimates for shielded stations, it is suggested that the front-of-wave protective level of the arrester be used as an approximation for the arrester voltage. In decisive situations, it is suggested that digital computer studies be performed in which the arrester and substation details can be modeled.

Protective Ratios

The three-point method is usually applied for insulation coordination. In this method the protective ratios are calculated at three separate points within the volt-time domain; namely switching surge, full wave, and chopped wave regions. If the following protective ratios are met or exceeded, satisfactory insulation coordination will be achieved according to the minimum recommendations given in ANSI C62.22.

These calculated protective ratios assume negligible arrester lead length and separation distance between the arrester and the transformer.

Figure 2

Arrester Voltage and current oscillograms for 10kA, 8/20 μ s current impulse test.

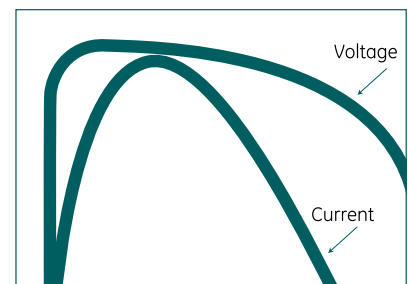

Cantilever Strength

Table 4 — Transformer Insulation Withstand

TRANSFORMER INSULATION WITHSTAND AND TEST WAVE	ARRESTER PROTECTIVE LEVEL AND TEST
Switching Surge 250/2500 μ s voltage	Switching surge 45 μ s current
Full wave 1.2/50 μ s voltage wave	Impulse 8/20 μ s current
Chopped wave 1.2/50 μ s voltage	Front-of-wave (0.5 μ s current wave)

Table 5 — Example of a 144kV Rated Protective Ratio Calculation

TRANSFORMER WITHSTAND TESTS	TRANSFORMER WITHSTAND VOLTAGES (kV)	ARRESTER PROTECTIVE LEVELS (kV)	PROTECTIVE RATIOS
Switching Surge	460	286	1.61
Full Wave	550	346	1.57
Chopped Wave	630	386	1.63

Polymer Station Class Arresters

Polymer AS Design Station Class - Electrical Characteristics — 4 hole NEMA and Eyebolt-for Indoor and Outdoor

STANDARD ARRESTER CATALOG NUMBER		ARRESTER RATINGS				MAXIMUM DISCHARGE VOLTAGE-8/20 CURRENT WAVE-kV					
4 HOLE NEMA	EYEBOLT TERMINAL ³	RATED VOLTAGE (kV) rms	MAXIMUM CONTINUOUS OPERATING VOLTAGE (Mcov) (kV) rms	MAXIMUM 0.5µS DISCHARGE VOLTAGE kV ⁽¹⁾	MAXIMUM SWITCHING SURGE PROTECTIVE LEVEL kV ⁽²⁾	1.5kA	3kA	5kA	10kA	20kA	40kA
9L11XPA003AS	9L11XPB003AS	3	2.55	10.5	6	6.4	6.7	7.1	7.6	8.2	9.3
9L11XPA006AS	9L11XPB006AS	6	5.1	18.6	12	12.8	13.5	14.1	15.2	16.4	18.7
9L11XPA009AS	9L11XPB009AS	9	7.65	27	18	19.2	20.2	21.2	22.7	24.6	28
9L11XPA010AS	9L11XPB010AS	10	8.4	29.4	19.8	21.1	22.2	23.3	25	27	30.8
9L11XPA012AS	9L11XPB012AS	12	10.2	35.1	24	25.6	26.9	28.2	30.3	32.8	37.4
9L11XPA015AS	9L11XPB015AS	15	12.7	43.4	29.9	31.9	33.5	35.2	37.7	40.8	46.5
9L11XPA018AS	9L11XPB018AS	18	15.3	51.6	36.1	38.5	40.4	42.4	45.5	49.1	56.1
9L11XPA021AS	9L11XPB021AS	21	17	57.8	40.1	42.7	44.9	47.1	50.5	54.6	62.3
9L11XPA024AS	9L11XPB024AS	24	19.5	65.7	45.9	49	51.5	54	57.9	62.6	71.4
9L11XPA027AS	9L11XPB027AS	27	22	73.6	51.8	55.3	58.1	60.9	65.4	70.7	80.6
9L11XPA030AS	9L11XPB030AS	30	24.4	81.2	57.5	61.3	64.5	67.6	72.5	78.4	89.4
9L11XPA036AS	9L11XPB036AS	36	29	97	68.6	73.2	76.9	80.7	86.5	93.6	107
9L11XPA039AS	9L11XPB039AS	39	31.5	105	74.4	79.3	83.4	87.4	93.8	101	116
9L11XPA045AS	9L11XPB045AS	45	36.5	121	86	91.8	96.4	101	108	117	134
9L11XPA048AS	9L11XPB048AS	48	39	129	91.9	98	103	108	116	125	143
9L11XPA054AS	9L11XPB054AS	54	42	145	104	111	116	122	131	141	161
9L11XPA060AS	9L11XPB060AS	60	48	160	114	122	128	134	144	156	178
9L11XPA072AS	9L11XPB072AS	72	57	192	137	147	154	161	173	187	214
9L11XPA090AS	9L11XPB090AS	90	74	245	174	186	195	205	220	238	271
9L11XPA096AS	9L11XPB096AS	96	76	257	184	196	206	216	232	251	286
9L11XPA108AS	9L11XPB108AS	108	84	289	207	221	232	244	261	283	322
9L11SPA108AS	(NEMA ONLY)	108	88	289	207	221	232	244	261	283	322
9L11XPA120AS	9L11XPB120AS	120	98	322	241	246	259	271	291	315	359
9L11XPA132AS	9L11XPB132AS	132	106	350	262	268	282	296	317	343	391
9L11XPA144AS	9L11XPB144AS	144	115	382	286	293	308	323	346	375	427
9L11XPA168AS	9L11XPB168AS	168	131	447	334	342	360	377	405	438	499
9L11XPA172AS	9L11XPB172AS	172	140	462	344	352	370	388	416	450	513
9L11XPA180AS	9L11XPB180AS	180	144	480	357	366	385	403	433	468	534
9L11XPA192AS	9L11XPB192AS	192	152	510	381	391	411	430	462	499	569
9L11XPA228AS	9L11XPB228AS	228	180	605	453	464	487	511	548	593	676

¹ Maximum discharge voltage for a 10kA impulse current wave which produces a voltage wave cresting in 0.5 µs. This can be used for coordination where front-of-wave sparkover was formerly used.

² Based on a 500A surge of 45-µs time to crest through 88kV MCOV, and 1,000A surge of 45-µs time to crest for 98kV MCOV and higher ratings.

³ For underhung (or upside down) mounting, with eyebolt terminal on the bottom, Change letter "B" to letter "E".

Polymer AS Design Station Class - Physical Characteristics
— 4 Hole NEMA-for Indoor and Outdoor Application

STANDARD ARRESTER CATALOG NUMBER		ARRESTER RATINGS					INSULATION WITHSTAND DISTANCE*					WEIGHT		CANTILEVER STRENGTH ⁽¹⁾		CANTILEVER STRENGTH ⁽²⁾	
4 HOLE NEMA	DUTY CYCLE (kV) rms	MCOV (kV) rms	HEIGHT "X" ⁽³⁾		POLYMER	CREEPAGE DISTANCE		PHASE TO PHASE		PHASE TO GROUND		lbs	kg	ft-lbs	Nm	ft-lbs	Nm
			in	mm	DRAWING	in	mm	in	mm	in	mm						
9L11XPA003AS	3	2.55	9.9	251	1	19.6	498	9	229	4.5	114	12.6	5.7	761	3383	1521	15039
9L11XPA006AS	6	5.1	9.9	251	1	19.6	498	9	229	4.5	114	12.6	5.7	761	3383	1521	15039
9L11XPA009AS	9	7.65	11.7	297	1	30.1	765	9	229	4.5	114	15.0	6.8	669	2974	1337	13221
9L11XPA010AS	10	8.4	11.7	297	1	30.1	765	9	229	4.5	114	15.0	6.8	669	2974	1337	13221
9L11XPA012AS	12	10.2	11.7	297	1	30.1	765	9	229	4.6	117	15.0	6.8	669	2974	1337	13221
9L11XPA015AS	15	12.7	13.5	343	1	35.4	899	9.7	246	5.4	137	17.3	7.8	595	2645	1190	11759
9L11XPA018AS	18	15.3	13.5	343	1	35.4	899	10.6	269	6.1	155	17.3	7.8	595	2645	1190	11759
9L11XPA021AS	21	17	17.2	437	1	40.5	1029	11.2	284	6.7	170	21.9	9.9	489	2174	977	9664
9L11XPA024AS	24	19.5	17.2	437	1	40.5	1029	12.1	307	7.4	188	21.9	9.9	489	2174	977	9664
9L11XPA027AS	27	22	17.2	437	1	40.5	1029	12.9	328	8.2	208	21.9	9.9	489	2174	977	9664
9L11XPA030AS	30	24.4	17.2	437	1	40.5	1029	13.8	351	8.9	226	21.9	9.9	489	2174	977	9664
9L11XPA036AS	36	29	20.9	531	1	50.9	1293	15.4	391	10.3	262	26.6	12.1	414	1840	829	8182
9L11XPA039AS	39	31.5	20.9	531	1	50.9	1293	16.2	411	11.1	282	26.6	12.1	414	1840	829	8182
9L11XPA045AS	45	36.5	24.5	622	1	61.5	1562	17.9	455	12.6	320	31.2	14.1	360	1600	720	7114
9L11XPA048AS	48	39	24.5	622	1	61.5	1562	18.8	478	13.3	338	31.2	14.1	360	1600	720	7114
9L11XPA054AS	54	42	24.5	622	1	61.5	1562	20.5	521	14.9	378	31.2	14.1	360	1600	720	7114
9L11XPA060AS	60	48	28.2	716	1	71.9	1826	22.1	561	16.2	411	35.9	16.3	313	1391	636	6186
9L11XPA072AS	72	57	31.9	810	1	82.4	2093	25.4	645	19.2	488	41.1	18.6	284	1263	569	5613
9L11XPA090AS	90	70	46.3	1176	2	123	3124	30.8	782	24	610	58.9	26.7	202	898	403	3992
9L11XPA096AS	96	76	46.3	1176	2	123	3124	32.2	818	25.2	640	58.9	26.7	202	898	403	3992
9L11XPA108AS	108	84	46.3	1176	2	123	3124	35.6	904	28.2	716	58.9	26.7	202	898	403	3992
9L11SPA005S	108	88	46.3	1176	2	123	3124	35.6	904	28.2	716	58.9	26.7	202	898	403	3992
9L11XPA120AS	120	98	53.7	1364	3	143.9	3655	48.6	1234	36	914	73.1	33.1	176	782	351	3478
9L11XPA132AS	132	106	53.7	1364	3	143.9	3655	51.6	1311	38.7	983	73.1	33.1	176	782	351	3478
9L11XPA144AS	144	115	61	1549	3	164.8	4186	55	1397	41.7	1059	82.1	37.2	156	693	311	3083
9L11XPA168AS	168	131	83.5	2121	4	184.5	4686	61.7	1567	47.7	1212	97.0	44.0	66	293	264	1304
9L11XPA172AS	172	140	83.5	2121	4	215.8	5481	74.4	1890	60.5	1537	120.0	54.4	58	258	230	1146
9L11XPA180AS	180	144	83.5	2121	4	215.8	5481	76.3	1938	62.4	1585	120.0	54.4	58	258	230	1146
9L11XPA192AS	192	152	83.5	2121	4	215.8	5481	79.7	2024	65.8	1671	120.0	54.4	58	258	230	1146
9L11XPA228AS	228	180	94.5	2400	4	247.2	6279	89.7	2278	75.7	1923	133.0	60.3	51	227	205	1008

* Center-to-Center

¹ Cantilever Strength- Maximum Working Strength

² Cantilever Strength- Rated Ultimate Cantilever Strength

³ Add 3.30" to "X" Dimension for 4 Hole Nema and 2.88" for Eyebolt designs for overall height

Note: Consult factory for extra high creep product options.

Polymer AS Design Station Class - Physical Characteristics — 4 Hole NEMA-for Indoor and Outdoor Applications (cont'd)

STANDARD ARRESTER CATALOG NUMBER		ARRESTER RATINGS					INSULATION WITHSTAND DISTANCE*					WEIGHT		CANTILEVER STRENGTH ⁽¹⁾		CANTILEVER STRENGTH ⁽²⁾	
4 HOLE NEMA	DUTY CYCLE (kV) rms	MCOV (kV) rms	HEIGHT "X" ⁽³⁾		POLYMER	CREEPAGE DISTANCE*		PHASE TO PHASE		PHASE TO GROUND		lbs	kg	ft-lbs	Nm	ft-lbs	Nm
			in	mm		DRAWING	in	mm	in	mm	in						
9L11XPB003AS	3	2.55	9.9	251	1	19.6	498	9	229	4.5	114	12.6	5.7	761	3383	1521	15039
9L11XPB006AS	6	5.1	9.9	251	1	19.6	498	9	229	4.5	114	12.6	5.7	761	3383	1521	15039
9L11XPB009AS	9	7.65	11.7	297	1	30.1	765	9	229	4.5	114	15.0	6.8	669	2974	1337	13221
9L11XPB010AS	10	8.4	11.7	297	1	30.1	765	9	229	4.5	114	15.0	6.8	669	2974	1337	13221
9L11XPB012AS	12	10.2	11.7	297	1	30.1	765	9	229	4.6	117	15.0	6.8	669	2974	1337	13221
9L11XPB015AS	15	12.7	13.5	343	1	35.4	899	9.7	246	5.4	137	17.3	7.8	595	2645	1190	11759
9L11XPB018AS	18	15.3	13.5	343	1	35.4	899	10.6	269	6.1	155	17.3	7.8	595	2645	1190	11759
9L11XPB021AS	21	17	17.2	437	1	40.5	1029	11.2	284	6.7	170	21.9	9.9	489	2174	977	9664
9L11XPB024AS	24	19.5	17.2	437	1	40.5	1029	12.1	307	7.4	188	21.9	9.9	489	2174	977	9664
9L11XPB027AS	27	22	17.2	437	1	40.5	1029	12.9	328	8.2	208	21.9	9.9	489	2174	977	9664
9L11XPB030AS	30	24.4	17.2	437	1	40.5	1029	13.8	351	8.9	226	21.9	9.9	489	2174	977	9664
9L11XPB036AS	36	29	20.9	531	1	50.9	1293	15.4	391	10.3	262	26.6	12.1	414	1840	829	8182
9L11XPB039AS	39	31.5	20.9	531	1	50.9	1293	16.2	411	11.1	282	26.6	12.1	414	1840	829	8182
9L11XPB045AS	45	36.5	24.5	622	1	61.5	1562	17.9	455	12.6	320	31.2	14.1	360	1600	720	7114
9L11XPB048AS	48	39	24.5	622	1	61.5	1562	18.8	478	13.3	338	31.2	14.1	360	1600	720	7114
9L11XPB054AS	54	42	24.5	622	1	61.5	1562	20.5	521	14.9	378	31.2	14.1	360	1600	720	7114
9L11XPB060AS	60	48	28.2	716	1	71.9	1826	22.1	561	16.2	411	35.9	16.3	313	1391	636	6186
9L11XPB072AS	72	57	31.9	810	1	82.4	2093	25.4	645	19.2	488	41.1	18.6	284	1263	569	5613
9L11XPB090AS	90	70	46.3	1176	2	123	3124	30.8	782	24	610	58.9	26.7	202	898	403	3992
9L11XPB096AS	96	76	46.3	1176	2	123	3124	32.2	818	25.2	640	58.9	26.7	202	898	403	3992
9L11XPB108AS	108	84	46.3	1176	2	123	3124	35.6	904	28.2	716	58.9	26.7	202	898	403	3992
(NEMA ONLY)	108	88	46.3	1176	2	123	3124	35.6	904	28.2	716	58.9	26.7	202	898	403	3992
9L11XPB120AS	120	98	53.7	1364	3	143.9	3655	48.6	1234	36	914	73.1	33.1	176	782	351	3478
9L11XPB132AS	132	106	53.7	1364	3	143.9	3655	51.6	1311	38.7	983	73.1	33.1	176	782	351	3478
9L11XPB144AS	144	115	61	1549	3	164.8	4186	55	1397	41.7	1059	82.1	37.2	156	693	311	3083
9L11XPB168AS	168	131	83.5	2121	3	184.5	4686	61.7	1567	47.7	1212	97.0	44.0	66	293	264	1304
9L11XPB172AS	172	140	83.5	2121	4	215.8	5481	74.4	1890	60.5	1537	120.0	54.4	58	258	230	1146
9L11XPB180AS	180	144	83.5	2121	4	215.8	5481	76.3	1938	62.4	1585	120.0	54.4	58	258	230	1146
9L11XPB192AS	192	152	83.5	2121	4	215.8	5481	79.7	2024	65.8	1671	120.0	54.4	58	258	230	1146
9L11XPB228AS	228	180	94.5	2400	4	247.2	6279	89.7	2278	75.7	1923	133.0	60.3	51	227	205	1008

* Center-to-Center

¹ Cantilever Strength- Maximum Working Strength

² Cantilever Strength- Rated Ultimate Cantilever Strength

³ Add 3.30" to "X" Dimension for 4 Hole Nema and 2.88" for Eyebolt designs for overall height

Note: Consult factory for extra high creep product options.

Drawing 1



Drawing 2

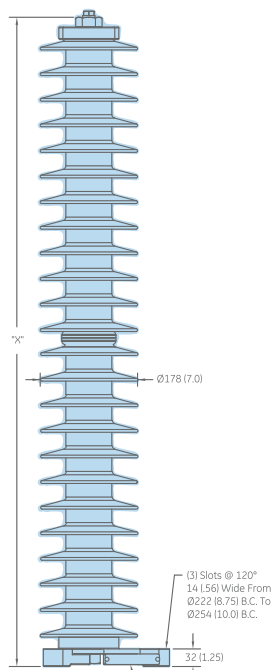

Drawing 3

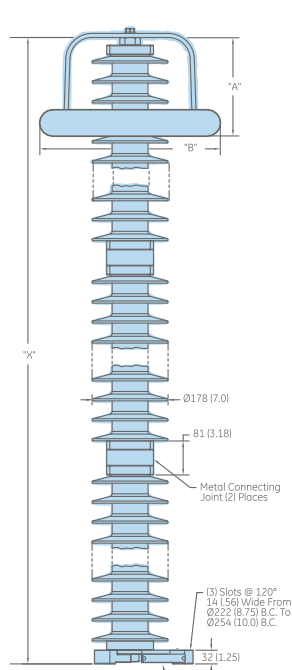

Drawing 4

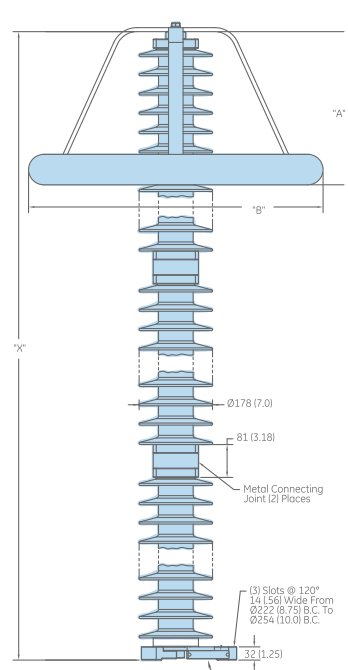

4 Hole NEMA Line Terminal

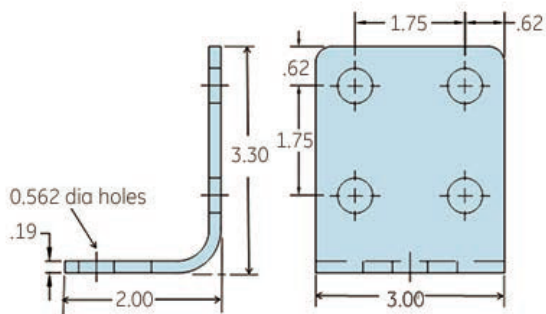

Eyebolt Line Terminal

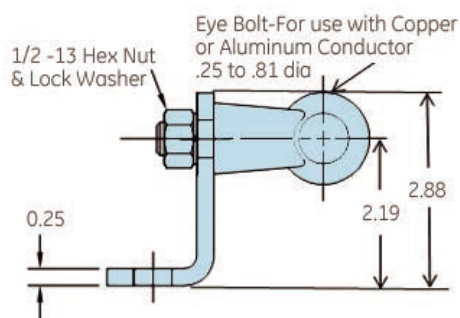

Grading Ring Dimension (inches)

ARRESTER RATING (kV)	"A" DROP	"B" DIAMETER
168	9.0	16.5
172 - 228	14.5	27.9

Porcelain S and AS Series Standard Station Class - Electrical Characteristics — 4 Hole NEMA-for Indoor and Outdoor Upright Mounting (“S” suffix below 54kV, “AS” suffix 54kV & above)

TYPE	ARRESTER RATINGS					MAXIMUM DISCHARGE VOLTAGE USING 8/20 CURRENT WAVE-kV					
	ARRESTER CATALOG NUMBER	RATED VOLTAGE (kV)	MAXIMUM CONTINUOUS OPERATING VOLTAGE (MCOV) (kV) rms	MAXIMUM 0.5µs DISCHARGE VOLTAGE kV ⁽¹⁾	MAXIMUM SWITCHING SURGE PROTECTIVE LEVEL kV ⁽²⁾	1.5kA	3kA	5kA	10kA	20kA	40kA
4 Hole NEMA	9L11ZGA003S	3	2.55	9.1	6.3	6.9	7.2	7.5	8	9	10.3
	9L11ZGA006S	6	5.1	17.9	12.4	13.6	14.2	14.8	15.8	17.7	20.3
	9L11ZGA009S	9	7.65	26.6	18.4	20.2	21.1	22	23.5	26.4	30.2
	9L11ZGA010S	10	8.4	29.3	20.3	22.2	23.3	24.2	25.9	29.1	33.3
	9L11ZGA012S	12	10.2	35.5	24.6	26.9	28.2	29.4	31.4	35.2	40.4
	9L11ZGA015S	15	12.7	44.2	30.6	33.5	35.1	36.6	39.1	43.9	50.3
	9L11ZGA018S	18	15.3	53.3	36.8	40.4	42.3	44.1	47.1	52.8	60.6
	9L11ZGA021S	21	17	59.1	40.9	44.8	46.9	48.9	52.3	58.7	67.2
	9L11ZGA024S	24	19.5	67.8	46.9	51.4	53.8	56.1	60	67.3	77.1
	9L11ZGA027S	27	22	76.5	52.9	58	60.8	63.3	67.7	75.9	87
	9L11ZGA030S	30	24.4	84.9	58.7	64.3	67.4	70.3	75.1	84.2	96.5
	9L11ZGA036S	36	29	101	69.7	76.4	80	83.4	89.2	100	115
	9L11ZGA039S	39	31.5	110	75.8	83	86.9	90.6	96.9	109	125
	9L11ZGA045S	45	36.5	128	88.3	96.8	102	106	113	127	146
	9L11ZGA048S	48	39	136	93.8	103	108	113	120	135	155
	9L11ZTA054AS	54	42	133	101	108	113	117	122	131	144
	9L11ZTA060AS	60	48	152	116	124	129	134	140	150	165
	9L11ZTA072AS	72	57	180	137	147	153	159	166	178	195
	9L11ZTA090AS	90	70	221	167	180	187	194	203	217	239
	Contact Factory	90	74	234	177	191	198	205	215	230	253
	9L11ZTA096AS	96	76	240	182	196	204	211	221	236	260
	9L11ZXA108AS	108	84	265	201	216	225	233	244	261	287
	9L11ZTA108AS	108	88	277	210	226	235	243	255	273	300
	9L11ZTA120AS	120	98	308	241	252	262	271	284	304	334
	9L11ZTA132AS	132	106	334	261	273	284	294	308	329	362
	9L11ZTA144AS	144	115	363	283	296	308	318	334	357	393
	9L11ZTA168AS	168	131	412	322	337	350	362	380	406	447
	9L11ZTA172AS	172	140	441	344	360	374	387	406	434	477
	9L11ZTA180AS	180	144	454	355	370	385	398	418	447	491
	9L11ZTA192AS	192	152	479	374	391	406	420	441	471	518
	9L11ZTA228AS	228	180	566	443	462	481	497	522	557	613
	9L11ZTA258AS	258	209	657	532	537	558	577	606	647	712
	9L11ZTA264AS	264	212	667	540	545	566	586	615	657	723
	9L11ZTA276AS	276	220	692	560	565	587	608	638	681	750
	9L11ZTA288AS	288	230	724	585	591	614	635	667	712	784
	9L11ZTA294AS	294	235	739	598	603	627	649	681	727	800
9L11ZTA300AS	300	243	765	619	624	649	672	705	753	828	
9L11ZTA312AS	312	245	770	623	629	654	676	710	758	834	
9L11ZTA336AS	336	274	861	697	703	731	756	794	848	933	
9L11ZTA360AS	360	288	906	733	739	769	795	835	891	981	
9L11ZTA396AS	396	318	1053	809	816	849	878	922	984	1083	
9L11ZTA420AS	420	335	1109	852	860	894	925	971	1037	1140	
9L11ZTA444AS	444	353	1169	898	906	942	974	1023	1092	1202	
9L16GNS588S	588	470	1469	1143	1159	1193	1225	1283	1348	1442	
9L16GNS612S	612	485	1516	1180	1196	1231	1264	1324	1391	1488	

Porcelain S Series Standard Station Class - Electrical Characteristics
— Eyebolt terminal for Indoor and Outdoor Upright Mounting*

TYPE	ARRESTER RATINGS					MAXIMUM DISCHARGE VOLTAGE USING 8/20 CURRENT WAVE-kV					
	ARRESTER CATALOG NUMBER	RATED VOLTAGE (kV)	MAXIMUM CONTINUOUS OPERATING VOLTAGE (MCOV) (kV) rms	MAXIMUM 0.5µs DISCHARGE VOLTAGE kV ⁽¹⁾	MAXIMUM SWITCHING SURGE PROTECTIVE LEVEL kV ⁽²⁾	1.5kA	3kA	5kA	10kA	20kA	40kA
Eyebolt Terminal	9L11ZGB003S	3	2.55	9.1	6.3	6.9	7.2	7.5	8	9	10.3
	9L11ZGB006S	6	5.1	17.9	12.4	13.6	14.2	14.8	15.8	17.7	20.3
	9L11ZGB009S	9	7.65	26.6	18.4	20.2	21.1	22	23.5	26.4	30.2
	9L11ZGB010S	10	8.4	29.3	20.3	22.2	23.3	24.2	25.9	29.1	33.3
	9L11ZGB012S	12	10.2	35.5	24.6	26.9	28.2	29.4	31.4	35.2	40.4
	9L11ZGB015S	15	12.7	44.2	30.6	33.5	35.1	36.6	39.1	43.9	50.3
	9L11ZGB018S	18	15.3	53.3	36.8	40.4	42.3	44.1	47.1	52.8	60.6
	9L11ZGB021S	21	17	59.1	40.9	44.8	46.9	48.9	52.3	58.7	67.2
	9L11ZGB024S	24	19.5	67.8	46.9	51.4	53.8	56.1	60	67.3	77.1
	9L11ZGB027S	27	22	76.5	52.9	58	60.8	63.3	67.7	75.9	87
	9L11ZGB030S	30	24.4	84.9	58.7	64.3	67.4	70.3	75.1	84.2	96.5
	9L11ZGB036S	36	29	101	69.7	76.4	80	83.4	89.2	100	115
	9L11ZGB039S	39	31.5	110	75.8	83	86.9	90.6	96.9	109	125
	9L11ZGB045S	45	36.5	128	88.3	96.8	102	106	113	127	146
9L11ZGB048S	48	39	136	93.8	103	108	113	120	135	155	

* Eyebolt mounting only available for below 54kV for porcelain station class arresters

¹ Maximum discharge voltage for an impulse current wave which produces a voltage wave cresting in 0.5 µs. Discharge currents are 10kA for 2.55 - 245kV MCOV. This can be used for coordination where front-of-wave sparkover formerly was used.

² Discharge voltages are based on a 500A surge of 45 µs time to crest through 88kV MOV and 1,000A surge of 45 µs-time to crest through 180kV MCOV and 2,000A through 245kV MCOV.

Porcelain S and AS Standard Station Class - Physical Characteristics — 4 Hole NEMA-for Indoor and Outdoor Upright Mounting

STANDARD ARRESTER CATALOG NUMBER	DUTY CYCLE (kV) rms	MCOV (kV) rms	DRAWING NUMBER	HEIGHT "X" ¹		CREEPAGE DISTANCE		INSULATION WITHSTAND DISTANCE*				WEIGHT	
				in	mm	in	mm	PHASE TO PHASE		PHASE TO GROUND		lbs	kg
								in	mm	in	mm	lbs	kg
9L11ZGA003S	3	2.55	2	19.13	485.9	6.2	157.5	12	304.8	6	152.4	65	29.5
9L11ZGA006S	6	5.1	2	19.13	485.9	6.2	157.5	12	304.8	7	177.8	65	29.5
9L11ZGA009S	9	7.65	2	19.13	485.9	6.2	157.5	13	330.2	7	177.8	66	30
9L11ZGA010S	10	8.4	2	19.13	485.9	6.2	157.5	13	330.2	8	203.2	66	30
9L11ZGA012S	12	10.2	2	21.13	536.7	11.1	281.9	14	355.6	8.5	215.9	72	32.7
9L11ZGA015S	15	12.7	2	21.13	536.7	11.1	281.9	14	355.6	8.5	215.9	73	33.2
9L11ZGA018S	18	15.3	2	24.13	612.9	20	508	16	406.4	9	228.6	80	36.4
9L11ZGA021S	21	17	2	24.13	612.9	20	508	16	406.4	9	228.6	81	36.8
9L11ZGA024S	24	19.5	2	24.13	612.9	20	508	17	431.8	11	279.4	82	37.3
9L11ZGA027S	27	22	2	28.13	714.5	31.7	805.2	18	457.2	12	304.8	90	40.9
9L11ZGA030S	30	24.4	2	28.13	714.5	31.7	805.2	18	457.2	12	304.8	91	41.4
9L11ZGA036S	36	29	2	28.13	714.5	31.7	805.2	20	508	14	355.6	93	42.3
9L11ZGA039S	39	31.5	2	31.88	809.8	41	1041.4	21	533.4	14	355.6	105	47.7
9L11ZGA045S	45	36.5	2	31.88	809.8	41	1041.4	21	533.4	15	381	107	48.6
9L11ZGA048S	48	39	2	31.88	809.8	41	1041.4	22	558.8	15	381	109	49.5
9L11ZTA054AS	54	42	3	38.13	969	75	1905	16.4	418	14.8	376	175	80
9L11ZTA060AS	60	48	3	38.13	969	75	1905	18.1	459	16.3	413	178	81
9L11ZTA066AS	66	53	3	38.13	969	75	1905	19.4	491	17.4	442	180	82
9L11ZTA072AS	72	57	3	38.13	969	75	1905	20.5	520	18.4	467	183	83
9L11ZTA090AS	90	70	3	44.13	1121	100	2540	23.8	604	21.3	541	217	99
9L11ZTA096AS	96	76	3	44.13	1121	100	2540	25.4	646	22.8	578	220	100
9L11SXA108AS	108	84	3	50.63	1286	126.3	3208	27.6	700	24.6	626	256	116
9L11ZTA108AS	108	88	3	50.63	1286	126.3	3208	28.6	726	25.6	649	257	117
9L11ZTA120AS	120	98	3	50.63	1286	126.3	3208	31.2	793	27.9	709	263	120
9L11ZTA132AS	132	106	4	57.13	1451	152.5	3874	33.4	848	29.8	757	294	134
9L11ZTA144AS	144	115	4	57.13	1451	152.5	3874	35.8	908	31.9	810	299	136
9L11ZTA168AS	168	131	4	76.63	1946	175	4445	40	1015	35.6	905	391	178
9L11ZTA172AS	172	140	5	76.63	1946	175	4445	60.8	1545	56.2	1428	414	188
9L11ZTA180AS	180	144	5	82.63	2099	200	5080	62	1574	57.2	1453	442	201
9L11ZTA192AS	192	152	5	82.63	2099	200	5080	64	1626	59	1499	446	203
9L11ZTA228AS	228	180	5	95.63	2429	252.5	6414	71.4	1812	65.5	1664	523	238
9L11ZTA240AS	240	190	5	95.63	2429	252.5	6414	74	1880	67.9	1724	529	240
9L11ZTA258AS	258	209	6	102.13	2594	278.8	7082	93.1	2363	86.3	2193	574	261
9L11ZTA264AS	264	212	6	102.13	2594	278.8	7082	93.9	2385	87.1	2212	575	261
9L11ZTA276AS	276	220	6	108.63	2759	305	7747	96	2437	88.9	2258	606	275
9L11ZTA288AS	288	230	6	108.63	2759	305	7747	98.6	2505	91.3	2318	611	278
9L11ZTA294AS	294	235	6	127.63	3242	326.3	8288	99.9	2537	92.4	2347	698	317
9L11ZTA300AS	300	243	6	127.63	3242	326.3	8288	102.1	2593	94.4	2398	702	319
9L11ZTA312AS	312	245	6	127.63	3242	326.3	8288	102.5	2604	94.7	2405	703	320
9L11ZTA336AS	336	274	6	134.13	3407	352.5	8954	110.2	2799	101.5	2578	749	340
9L11ZTA360AS	360	288	6	140.63	3572	378.8	9621	113.9	2893	104.8	2662	788	358
9L11ZTA396AS	396	318	7	153.63	3902	431.3	10955	142.9	3629	132.8	3374	890	405
9L11ZTA420AS	420	335	7	160.13	4067	457.6	11623	147.4	3744	136.8	3475	927	421
9L11ZTA444AS	444	353	7	179.13	4550	478.8	12162	152.1	3863	141	3581	1024	465
9L16GNS588S	588	470		276.8	7031	595	15113	232.5	5906	215.4	5471	3674	1670
9L16GNS612S	612	485		286.1	7267	627	15919	237.1	6021	219.5	5575	3774	1716

* Center-to-Center

¹ 3.30" to "X" Dimension for 4 Hole Nema and 2.88" for Eyebolt designs for overall height

Note: Consult factory for extra high creep product options

Porcelain S Series Standard Station Class - Physical Characteristics
 — Eyebolt terminal for Indoor and Outdoor Upright Mounting*

STANDARD ARRESTER CATALOG NUMBER	DUTY CYCLE (kV) rms	MCOV (kV)rms	DRAWING NUMBER	HEIGHT "X" ¹				INSULATION WITHSTAND DISTANCE*				WEIGHT	
				CREEPAGE DISTANCE		PHASE TO PHASE		PHASE TO GROUND		lbs	kg		
				in	mm	in	mm	in	mm			in	mm
9L11ZGB003S	3	2.55	2A	19.13	485.9	6.2	157.5	12	304.8	6	152.4	65	29.5
9L11ZGB006S	6	5.1	2A	19.13	485.9	6.2	157.5	12	304.8	7	177.8	65	29.5
9L11ZGB009S	9	7.65	2A	19.13	485.9	6.2	157.5	13	330.2	7	177.8	66	30.0
9L11ZGB010S	10	8.4	2A	19.13	485.9	6.2	157.5	13	330.2	8	203.2	66	30.0
9L11ZGB012S	12	10.2	2A	21.13	536.7	11.1	281.9	14	355.6	8.5	215.9	72	32.7
9L11ZGB015S	15	12.7	2A	21.13	536.7	11.1	281.9	14	355.6	8.5	215.9	73	33.2
9L11ZGB018S	18	15.3	2A	24.13	612.9	20	508.0	16	406.4	9	228.6	80	36.4
9L11ZGB021S	21	17	2A	24.13	612.9	20	508.0	16	406.4	9	228.6	81	36.8
9L11ZGB024S	24	19.5	2A	24.13	612.9	20	508.0	17	431.8	11	279.4	82	37.3
9L11ZGB027S	27	22	2A	28.13	714.5	31.7	805.2	18	457.2	12	304.8	90	40.9
9L11ZGB030S	30	24.4	2A	28.13	714.5	31.7	805.2	18	457.2	12	304.8	91	41.4
9L11ZGB036S	36	29	2A	28.13	714.5	31.7	805.2	20	508	14	355.6	93	42.3
9L11ZGB039S	39	31.5	2A	31.88	809.8	41	1041.4	21	533.4	14	355.6	105	47.7
9L11ZGB045S	45	36.5	2A	31.88	809.8	41	1041.4	21	533.4	15	381	107	48.6
9L11ZGB048S	48	39	2A	31.88	809.8	41	1041.4	22	558.8	15	381	109	49.5

* Eyebolt mounting only available for below 54kV for porcelain station class arresters

** Center-to-Center

¹ Add 2.88 inches to "X" height for eyebolt terminal designs for overall height

Note: Consult factory for extra high creep product options

Drawing 2

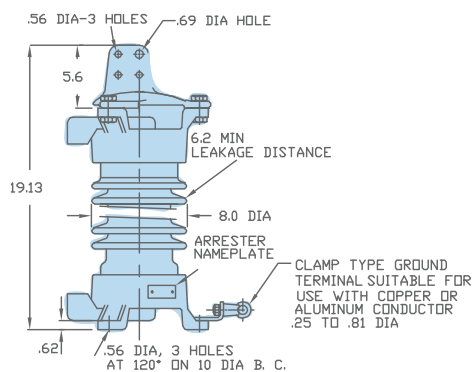

Drawing 2A

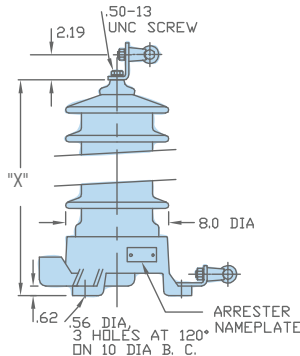

Drawing 3

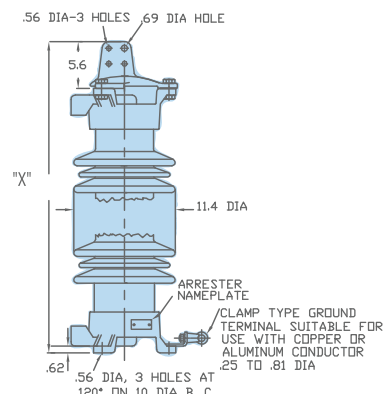

Drawing 4

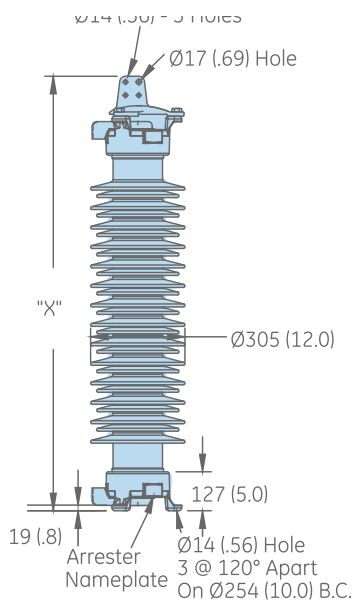

Drawing 5

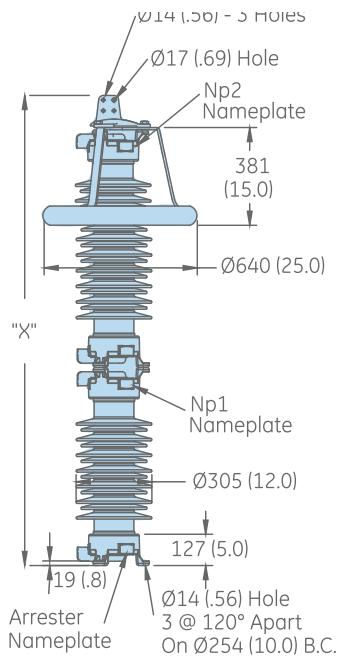

Drawing 6

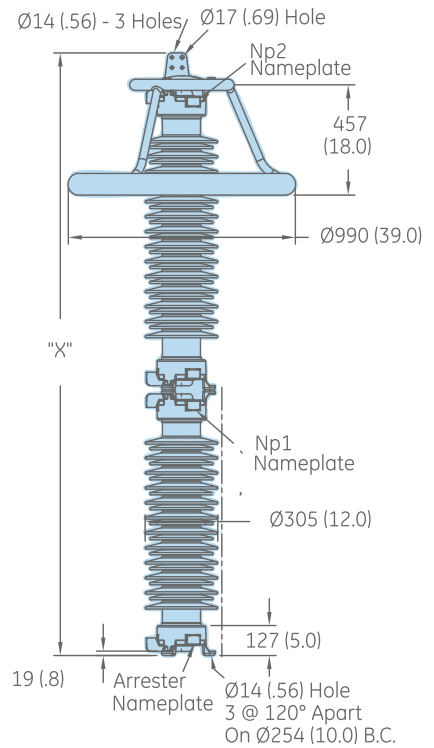

Drawing 7

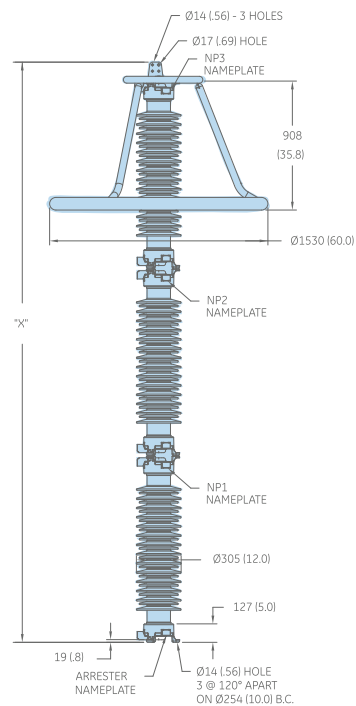

4 Hole NEMA Terminal

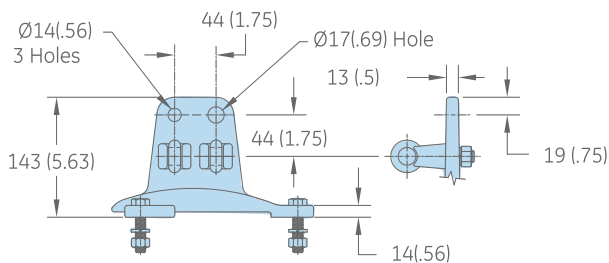

Hdg 4-hole Terminal Pad
 Two Hdg Terminals
 Suitable For Cu Or Al Conductor Size
 Ø 7 (.25) - Ø 21 (.81) Dia
 25 - 240 Sq Mm
 Awg#4 - 500 Mcm

NOTES:

1. Dimensions in millimeters(inches) subject to ±3% tolerance
2. Clearance and insulation w/s voltage apply at sea level
3. Arrester suitable for operation at altitudes up to 1950m (6400ft)

Silicon Station Class Arresters

Electrical Characteristics

— 4 Hole NEMA-for Indoor or Outdoor Mounting

ARRESTER RATINGS					MAXIMUM DISCHARGE VOLTAGE USING 8/20 CURRENT WAVE-kV					
ARRESTER CATALOG NUMBER	RATED VOLTAGE (kV)	MAXIMUM CONTINUOUS OPERATING VOLTAGE (MCOV) (kV) rms	MAXIMUM 0.5 μ s DISCHARGE VOLTAGE kV ⁽¹⁾	MAXIMUM SWITCHING SURGE PROTECTIVE LEVEL kV ⁽²⁾	1.5kA	3kA	5kA	10kA	20kA	40kA
9L11HMA054S	54	42	133	94	103	108	113	121	131	146
9L11HMA060S	60	48	152	107	118	124	129	138	150	166
9L11HMA072S	72	57	181	127	140	147	153	164	178	198
9L11HMA090S	90	70	222	156	172	181	188	201	218	243
9L11HMA090S	90	74	235	165	182	191	199	213	231	256
9L11HMA096S	96	76	241	170	187	196	205	218	237	263
9L11HMA108S	108	84	266	187	207	217	226	241	262	291
9L11HMA108S	108	88	279	196	217	227	237	253	274	305
9L11HMA120S	120	98	311	228	241	253	264	282	305	340
9L11HMA132S	132	106	336	247	261	274	285	305	330	367
9L11HMA144S	144	115	365	268	283	297	310	330	358	399
9L11HMA168S	168	131	416	305	323	338	353	376	408	454
9L11HMA172S	172	140	444	326	345	362	377	402	436	485
9L11HMA180S	180	144	457	335	355	372	388	414	449	499
9L11HMA192S	192	152	482	354	374	393	409	437	473	527
9L11HMA228S	228	180	571	419	443	465	485	517	561	624
9L11HMA240S	240	190	602	472	468	491	511	546	592	658
9L11HMA258S	258	209	663	519	515	540	563	601	651	724
9L11HMA264S	264	212	673	526	522	548	571	609	660	735
9L11HMA276S	276	220	698	546	542	568	592	632	685	762
9L11HMA288S	288	230	729	571	566	594	619	661	716	797
9L11HMA312S	312	245	777	608	603	633	660	704	763	849
9L11HMA396S	396	318	1009	790	783	821	856	914	991	1102
9L11HMA420S	420	335	1063	832	825	865	902	963	1043	1161
9L11HMA444S	444	353	1120	876	869	912	950	1014	1100	1223

¹ Maximum discharge voltage for an impulse current wave which produces a voltage wave cresting in 0.5 μ s. Discharge currents are 10kA for 2.55 - 245kV MCOV. This can be used for coordination where front-of-wave sparkover formerly was used.

² Discharge voltages are based on a 500A surge of 45 μ s time to crest through 88kV MOV and 1,000A surge of 45 μ s-time to crest through 180kV MCOV and 2,000A through 245kV MCOV.

Mechanical Characteristics — 4 Hole NEMA-for Indoor or Outdoor Mounting

STANDARD ARRESTER CATALOG NUMBER	DUTY CYCLE (kV) rms	MCOV (kV) rms	DRAWING NUMBER	INSULATION WITHSTAND DISTANCE									
				HEIGHT "X"		CREEPAGE DISTANCE		PHASE TO PHASE		PHASE TO GROUND		WEIGHT	
				in	mm	in	mm	in	mm	in	mm	lbs	kg
9L11HMA054S	54	42	1	38.1	967.7	83	2108.2	15.6	396.2	10.9	276.9	104	47
9L11HMA060S	60	48	1	38.1	967.7	83	2108.2	17.1	434.3	12.5	317.5	107	48
9L11HMA072S	72	57	1	38.1	967.7	83	2108.2	19.5	495.3	14.8	375.9	112	51
9L11HMA090S	90	70	1	44.4	1127.8	113	2870.2	26	660.4	18.2	462.3	125	57
9L11HMA590S	90	74	1	44.4	1127.8	113	2870.2	27	685.8	19.2	487.7	128	58
9L11HMA096S	96	76	1	44.4	1127.8	113	2870.2	27.5	698.5	19.8	502.9	130	59
9L11HMA108S	108	84	1	52.1	1323.3	142	3606.8	31.2	792.5	21.8	553.7	141	64
9L11HMA108S	108	88	1	52.1	1323.3	142	3606.8	32.2	817.9	22.9	581.7	144	65
9L11HMA120S	120	98	1	52.1	1323.3	142	3606.8	36.4	924.6	25.5	647.7	149	68
9L11HMA132S	132	106	1	58.8	1493.5	171	4343.4	38.4	975.4	27.6	701	167	76
9L11HMA144S	144	115	1	58.8	1493.5	171	4343.4	40.8	1036.3	29.9	759.5	172	78
9L11HMA168S	168	131	2	76.9	1953.3	196	4978.4	44.9	1140.5	34.1	866.1	231	105
9L11HMA172S	172	140	3	76.9	1953.3	196	4978.4	77	1955.8	48.9	1242.1	257	116
9L11HMA180S	180	144	3	76.9	1953.3	196	4978.4	78	1981.2	50	1270	257	116
9L11HMA192S	192	152	3	83.2	2113.3	225	5715	80.1	2034.5	52	1320.8	262	119
9L11HMA228S	228	180	3	90.9	2308.9	254	6451.6	87.4	2220	59.3	1506.2	291	132
9L11HMA240S	240	190	3	98.6	2504.4	285	7239	90	2286	61.9	1572.3	317	144
9L11HMA258S	258	209	3	105.3	2674.6	313	7950.2	116.6	2961.6	73.9	1877.1	330	150
9L11HMA264S	264	212	3	105.3	2674.6	313	7950.2	117.4	2982	74.6	1894.8	349	158
9L11HMA276S	276	220	3	105.3	2674.6	313	7950.2	119.5	3035.3	76.7	1948.2	351	159
9L11HMA288S	288	230	3	112	2844.8	344	8737.6	122.1	3101.3	79.3	2014.2	360	163
9L11HMA312S	312	245	4	129.7	3294.4	367	9321.8	126	3200.4	83.2	2113.3	406	184
9L11HMA396S	396	318	4	151.8	3855.7	455	11557	178.4	4531.4	112.9	2867.7	532	241
9L11HMA420S	420	335	4	158.5	4025.9	484	12293.6	182.8	4643.1	117.3	2979.4	539	244
9L11HMA444S	444	353	4	165.2	4196.1	514	13055.6	187.5	4762.5	122	3098.8	564	256

Drawing 1

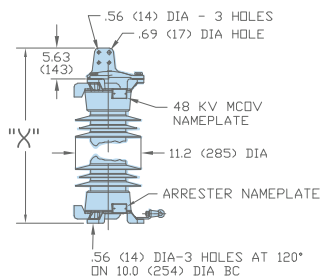

Drawing 2

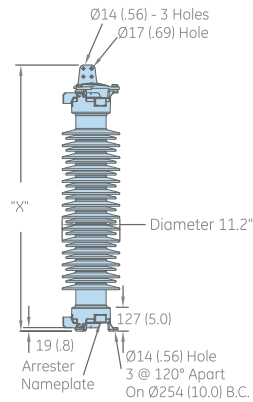

Drawing 3

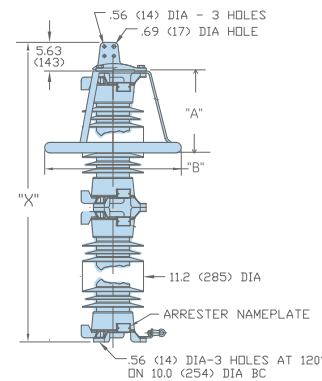

Drawing 4

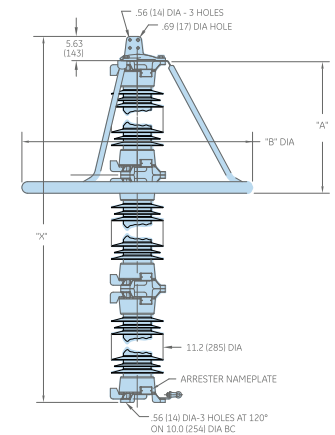

Grading Ring Dimension (inches)

ARRESTER RATING (kV)	"A" DROP	"B" DIAMETER
172 - 240	15.0	25.2
258 - 312	18.0	39.0
396 - 420	46.0	80.0
444	35.8	60.3

Polymer Intermediate Class Arresters

Electrical Characteristics

GE VERNOVA CATALOG		ARRESTER RATINGS				MAXIMUM DISCHARGE VOLTAGE USING AN 8/20 CURRENT WAVE-kV					
# 4 HOLE NEMA	# EYEBOLT	DUTY CYCLE RATING (kV) rms	MAXIMUM CONTINUOUS OPERATING VOLTAGE (MCOV) (kV) rms	MAXIMUM 0.5 μ S DISCHARGE VOLTAGE kV ⁽¹⁾	MAXIMUM SWITCHING SURGE PROTECTIVE LEVEL kV ⁽²⁾	1.5kA	3kA	5kA	10kA	20kA	40kA
9L12PPA003S	9L12PPB003S	3	2.55	8.6	6.4	6.8	7.2	7.5	8.1	9	10.1
9L12PPA006S	9L12PPB006S	6	5.1	17.1	12.7	13.6	14.4	15	16.2	17.9	20.2
9L12PPA009S	9L12PPB009S	9	7.65	25.8	19.1	20.5	21.6	22.6	24.4	27	30.4
9L12PPA010S	9L12PPB010S	10	8.4	28.4	21.1	22.6	23.8	24.9	26.9	29.8	33.5
9L12PPA012S	9L12PPB012S	12	10.2	34.1	25.3	27.1	28.6	29.9	32.3	35.8	40.3
9L12PPA015S	9L12PPB015S	15	12.7	42.9	31.8	34.1	36	37.6	40.6	44.9	50.6
9L12PPA018S	9L12PPB018S	18	15.3	51.6	38.3	40.9	43.2	45.2	48.8	54	60.9
9L12PPA021S	9L12PPB021S	21	17	56.9	42.2	45.1	47.7	49.9	53.8	59.6	67.1
9L12PPA024S	9L12PPB024S	24	19.5	68.3	50.6	54.2	57.2	59.9	64.6	71.5	80.6
9L12PPA027S	9L12PPB027S	27	22	77.4	57.4	61.4	64.9	67.9	73.2	81	91.3
9L12PPA030S	9L12PPB030S	30	24.4	85.3	63.3	67.7	71.5	74.8	80.7	89.3	101
9L12PPA036S	9L12PPB036S	36	29	102	76	81.3	85.9	89.8	96.9	107	121
9L12PPA039S	9L12PPB039S	39	31.5	108.4	80.4	86.1	90.9	95.1	102.6	113.6	127.9
9L12PPA045S	9L12PPB045S	45	36.5	125.1	92.8	99.3	104.9	109.8	118.4	131.1	147.6
9L12PPA048S	9L12PPB048S	48	39	136.6	101.3	108.4	114.5	119.8	129.2	143	161.1
9L12PPA054S	9L12PPB054S	54	42	147.9	109.7	117.4	125	129.7	139.9	154.9	174.5
9L12PPA060S	9L12PPB060S	60	48	165	122.4	131	138.3	144.7	156.1	172.8	195
9L12PPA072S	9L12PPB072S	72	57	199	147.7	158.1	166.9	174.6	188.4	209	235
9L12PPA090S	9L12PPB090S	90	70	250	185.7	198.7	209.8	219.5	236.8	262	295
9L12PPA096S	9L12PPB096S	96	76	261.7	194.1	207.7	219.4	229.5	247.6	274.1	308.8
9L12PPA108S	9L12PPB108S	108	88	296	219.5	234.9	248.1	259.6	280	310	349.2
9L12PPA120S	9L12PPB120S	120	98	327.7	243	26.1	274.7	287.4	310	343.2	386.6
9L12PPA132S	9L12PPB132S	132	106	375.2	278.3	297.8	314.5	329.1	355	393	443
9L12PPA144S	9L12PPB144S	144	115	392	290.9	311.3	328.7	343.9	371	411	463

¹ Maximum discharge voltage for an impulse current wave which produces a voltage wave cresting in 0.5 μ s. Discharge currents are 10kA for 2.55 - 245kV MCOV. This can be used for coordination where front-of-wave sparkover formerly was used.

² Discharge voltages are based on a 500A surge of 45 μ s time to crest through 88kV MOV and 1,000A surge of 45 μ s-time to crest through 180kV MCOV and 2,000A through 245kV MCOV.

4 Hole NEMA-for Indoor or Outdoor Upright Mounting — Mechanical Characteristics

STANDARD ARRESTER CATALOG NUMBER		ARRESTER RATINGS						INSULATION WITHSTAND DISTANCE*					
4 HOLE NEMA	DUTY CYCLE (kV) rms	MCOV (kV) rms	DRAWING NUMBER	"X" DIMENSIONS ¹		LEAKAGE		PHASE TO PHASE		PHASE TO GROUND		WEIGHT	
				in	mm	in	mm	in	mm	in	mm	lbs	kg
9L12PPA003S	3	2.55	1	6.8	172.7	15.4	391.2	4.4	111.8	3.3	83.8	6.2	2.8
9L12PPA006S	6	5.1	1	6.8	172.7	15.4	391.2	4.6	116.8	3.2	81.3	6.2	2.8
9L12PPA009S	9	7.65	1	6.8	172.7	15.4	391.2	4.7	119.4	3.3	83.8	6.2	2.8
9L12PPA010S	10	8.4	1	6.8	172.7	15.4	391.2	4.9	124.5	3.5	88.9	6.2	2.8
9L12PPA012AS	12	10.2	1	6.8	172.7	15.4	391.2	4.9	124.5	3.5	88.9	6.2	2.8
9L12PPA015S	15	12.7	1	12.2	309.9	30.8	782.3	6.2	157.5	4.8	121.9	10.0	4.5
9L12PPA018S	18	15.3	1	12.2	309.9	30.8	782.3	6.6	167.6	5.2	132.1	10.0	4.5
9L12PPA021S	21	17	1	12.2	309.9	30.8	782.3	7.6	193.0	6.2	157.5	10.0	4.5
9L12PPA024AS	24	19.5	1	12.2	309.9	30.8	782.3	7.6	193.0	6.2	157.5	10.0	4.5
9L12PPA027S	27	22	1	17.6	447.0	46.2	1173.5	9.6	243.8	8.2	208.3	13.5	6.1
9L12PPA030S	30	24.4	1	17.6	447.0	46.2	1173.5	9.8	248.9	8.4	213.4	13.5	6.1
9L12PPA036AS	36	29	1	17.6	447.0	46.2	1173.5	9.8	248.9	8.4	213.4	13.5	6.1
9L12PPA039S	39	31.5	1	23.0	584.2	61.6	1564.6	12.8	325.1	11.4	289.6	17.0	7.7
9L12PPA045AS	45	36.5	1	23.0	584.2	61.6	1564.6	12.8	325.1	11.4	289.6	17.0	7.7
9L12PPA048AS	48	39	1	23.0	584.2	61.6	1564.6	12.8	325.1	11.4	289.6	17.0	7.7
9L12PPA054AS	54	42	1	28.4	721.4	77.0	1955.8	15.8	401.3	14.4	365.8	19.6	8.9
9L12PPA060AS	60	48	1	28.4	721.4	77.0	1955.8	15.8	401.3	14.4	365.8	19.6	8.9
9L12PPA072AS	72	57	1	33.8	858.5	92.4	2347.0	19.8	502.9	18.4	467.4	23.1	10.5
9L12PPA090S	90	70	2	44.0	1117.6	109.0	2768.6	40.0	1016.0	33.0	838.2	52	23.6
9L12PPA096S	96	76	2	44.0	1117.6	109.0	2768.6	42.0	1066.8	35.0	889.0	53	24.1
9L12PPA108S	108	88	2	44.0	1117.6	109.0	2768.6	46.0	1168.4	39.0	990.6	54	24.5
9L12PPA120S	120	98	2	66.5	1689.1	162.0	4114.8	51.0	1295.4	44.0	1117.6	67.5	30.7
9L12PPA132S	132	106	2	66.5	1689.1	162.0	4114.8	55.0	1397.0	47.0	1193.8	67.5	30.7
9L12PPA144S	144	115	2	66.5	1689.1	162.0	4114.8	58.0	1473.2	50.0	1270.0	67.5	30.7

* Center-to-Center

¹ For NEMA Arresters rated up to 72 kV (Drawing 1), add 3.30" to the "X" Dimension for overall height.

Note: Consult factory for extra high creep product options.

Drawing 1

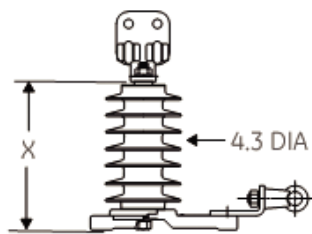

Drawing 2

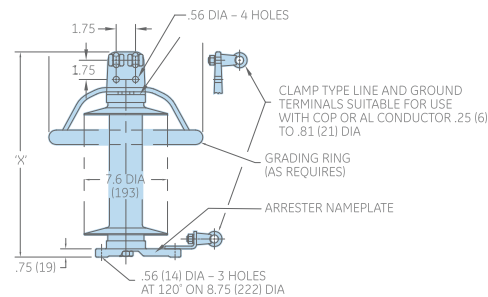

Grading Ring Dimension (inches)

ARRESTER RATING (kV)	"A" DROP	"B" DIAMETER
90 - 108	14.0	4.8
120 - 144	16.5	9.0

Eyebolt-for Indoor or Outdoor Upright Mounting — Mechanical Characteristics

STANDARD ARRESTER CATALOG NUMBER		ARRESTER RATINGS					INSULATION WITHSTAND DISTANCE*				WEIGHT		
EYEBOLT TERMINAL	DUTY CYCLE (kV) rms	MCOV (kV) rms	DRAWING NUMBER	"X" DIMENSIONS ¹		LEAKAGE		PHASE TO PHASE		PHASE TO GROUND		in	mm
				in	mm	in	mm	in	mm	in	mm		
9L12PPB003S	3	2.55	3	6.8	172.7	15.4	391.2	4.4	111.8	3.3	83.8	6.2	2.8
9L12PPB006S	6	5.1	3	6.8	172.7	15.4	391.2	4.6	116.8	3.2	81.3	6.2	2.8
9L12PPB009S	9	7.65	3	6.8	172.7	15.4	391.2	4.7	119.4	3.3	83.8	6.2	2.8
9L12PPB010S	10	8.4	3	6.8	172.7	15.4	391.2	4.9	124.5	3.5	88.9	6.2	2.8
9L12PPB012S	12	10.2	3	6.8	172.7	15.4	391.2	4.9	124.5	3.5	88.9	6.2	2.8
9L12PPB015S	15	12.7	3	12.2	309.9	30.8	782.3	6.2	157.5	4.8	121.9	10	4.5
9L12PPB018S	18	15.3	3	12.2	309.9	30.8	782.3	6.6	167.6	5.2	132.1	10	4.5
9L12PPB021S	21	17	3	12.2	309.9	30.8	782.3	7.6	193.0	6.2	157.5	10	4.5
9L12PPB024S	24	19.5	3	12.2	309.9	30.8	782.3	7.6	193.0	6.2	157.5	10	4.5
9L12PPB027S	27	22	3	17.6	447.0	46.2	1173.5	9.6	243.8	8.2	208.3	13.5	6.1
9L12PPB030S	30	24.4	3	17.6	447.0	46.2	1173.5	9.8	248.9	8.4	213.4	13.5	6.1
9L12PPB036S	36	29	3	17.6	447.0	46.2	1173.5	9.8	248.9	8.4	213.4	13.5	6.1
9L12PPB039S	39	31.5	3	23.0	584.2	61.6	1564.6	12.8	325.1	11.4	289.6	17	7.7
9L12PPB045S	45	36.5	3	23.0	584.2	61.6	1564.6	12.8	325.1	11.4	289.6	17	7.7
9L12PPB048S	48	39	3	23.0	584.2	61.6	1564.6	12.8	325.1	11.4	289.6	17	7.7
9L12PPB054S	54	42	3	28.4	721.4	77.0	1955.8	15.8	401.3	14.4	365.8	19.6	8.9
9L12PPB060S	60	48	3	28.4	721.4	77.0	1955.8	15.8	401.3	14.4	365.8	19.6	8.9
9L12PPB072S	72	57	3	33.8	858.5	92.4	2347.0	19.8	502.9	18.4	467.4	23.1	10.5
9L12PPB090S	90	70	4	44.0	1117.6	109.0	2768.6	40.0	1016.0	33.0	838.2	52	23.6
9L12PPB096S	96	76	4	44.0	1117.6	109.0	2768.6	42.0	1066.8	35.0	889.0	53	24.1
9L12PPB108S	108	88	4	44.0	1117.6	109.0	2768.6	46.0	1168.4	39.0	990.6	54	24.5
9L12PPB120S	120	98	4	66.5	1689.1	162.0	4114.8	51.0	1295.4	44.0	1117.6	67.5	30.7
9L12PPB132S	132	106	4	66.5	1689.1	162.0	4114.8	55.0	1397.0	47.0	1193.8	67.5	30.7
9L12PPB144S	144	115	4	66.5	1689.1	162.0	4114.8	58.0	1473.2	50.0	1270.0	67.5	30.7

* Center-to-Center

¹ For Eyebolt Terminal Arresters add 2.88" to the "X" Dimension for overall height.

Note: Consult factory for extra high creep product options.

Drawing 3

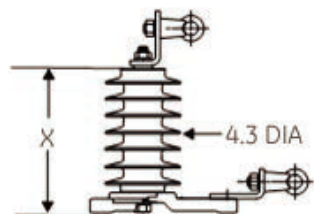

Drawing 4

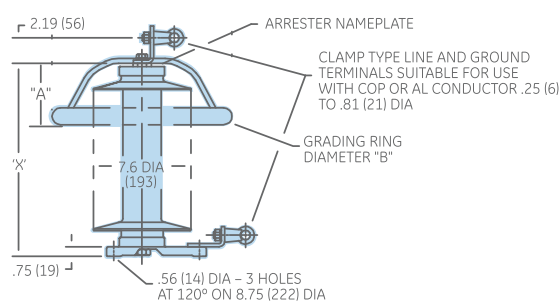

Grading Ring Dimension (inches)

ARRESTER RATING (kV)	"A" DROP	"B" DIAMETER
90 - 108	14.0	4.8
120 - 144	16.5	9.0

For more information, visit
governova.com/grid-solutions

TRANQUELL is trademark of General Electric Company. ANSI is a registered trademark of American National Standards Institute, Incorporated. IEC is a registered trademark of Commission Electrotechnique Internationale. IEEE is a registered trademark of the Institute of Electrical Electronics Engineers, Inc.

GE Vernova reserves the right to make changes to specifications of products described at any time without notice and without obligation to notify any person of such changes.

© 2025 GE Vernova and/or its affiliates. All rights reserved. GE and the GE Monogram are trademarks of General Electric Company used under trademark license.



GE VERNOVA

GEA-271A (Rev 0)
English
250902