

RAIL ENERGY HUBS: INTEGRATION OF RENEWABLE ENERGY SOURCES INTO RAILWAY NETWORKS

Electrification and decarbonization is best achieved by integrating decentralized or distributed renewable generation.

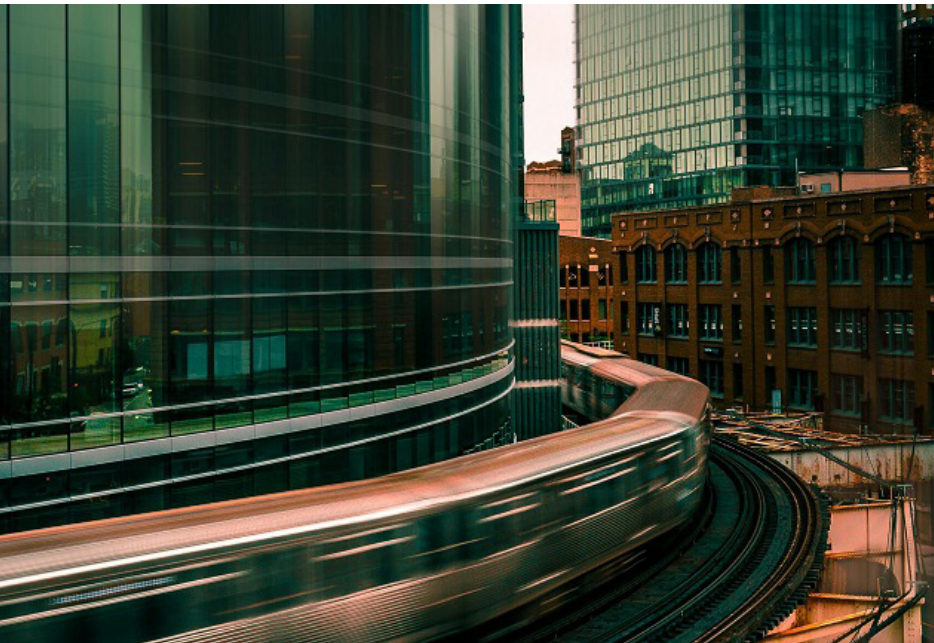

Across the globe, both rail grid operators and transmission and distribution system grid operators are facing growing challenges of limited grid capacity, reliability and power quality for railway network power supplies. Integrating renewable generation with battery energy storage between the transmission/distribution grids and railway grids can help both sides to meet growing energy demand, improve reliability, and address the complex market needs.

BUSINESS CASE BUILT ON COMBINED VALUE PROPOSITION

Having at least three stakeholders requires a business case which benefits all sides. Rail Energy Hubs can provide stakeholders with flexible commercial options and benefits.

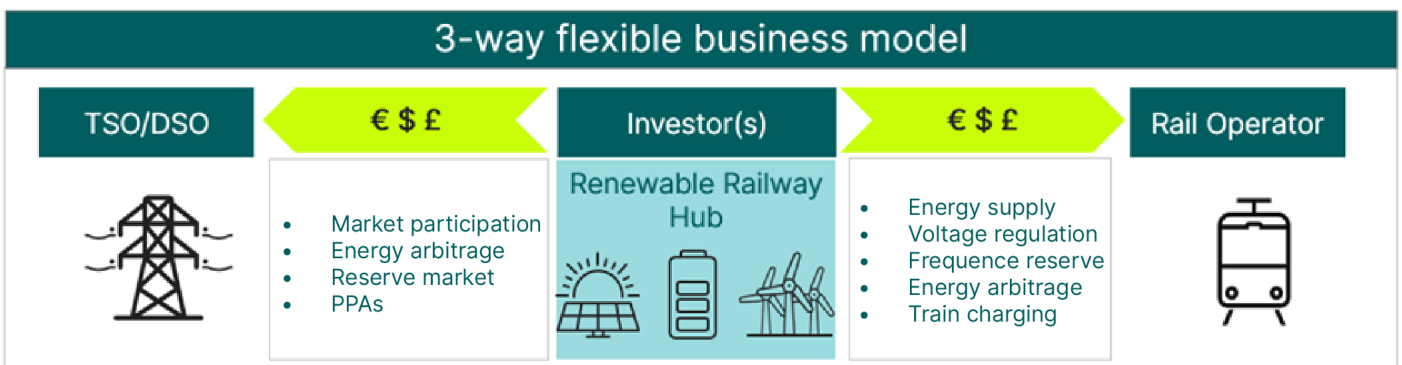

Low voltage solution for small Rail Energy Hubs

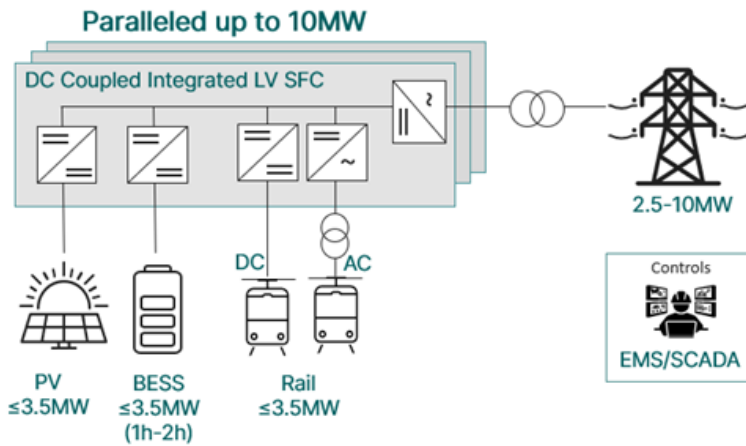

GE Vernova Scope:

SFC, BESS, PV, Control, BoS

Main Features of the SFC:

Technology: IGBT

Frequency and Voltage:

- AC: 50Hz/60Hz at 25kV
- DC: 750V, 1.500V, 3.000V
- Voltage fluctuation: +/- 10%
- Power range: 2.5 - 10MW
- Liquid-cooled

Medium-voltage solution for large scale renewable integration

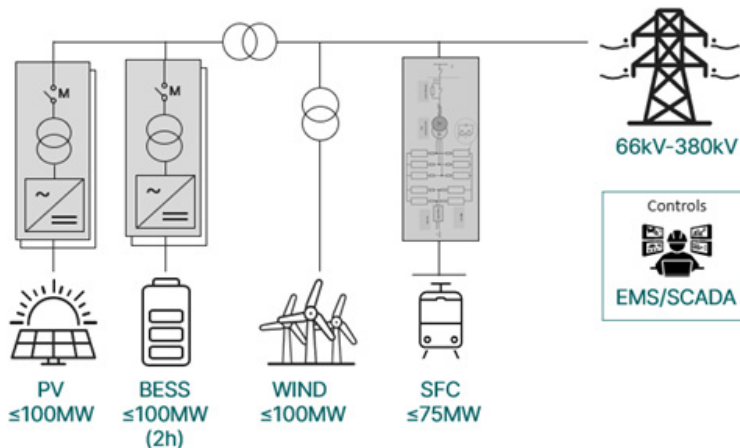

GE Vernova Scope:

SFC, BESS, PV, Wind, Controls, BoS

Main Features of the SFC:

Configuration: AFE/AFE

Frequency and Voltage:

- 16.7Hz at 15kV
- 50Hz/60Hz at 25kV
- Voltage fluctuation: +/- 10%
- Power range: 20-80+ MVA
- Network PF Control: Yes

PROVEN TECHNOLOGY FOR RELIABILITY AND AVAILABILITY

MM7 - MV SFC

Key features:

- Scalable up to 300 MVA, 36 kV in power through standard and modular power cells arrangement
- Redundancy N+1 — containment of single failure at local submodule level
- Transformerless solutions are available at system voltage up to 36kV

Benefits:

- Transformer-less design allows for compactness
- Increased system stability and power quality (including Pst flicker for EAF)
- Decreased down time
- Low harmonics without additional passive components

LV3 - LV SFC

Key features:

- Integrated dynamic-brake
- Filter-less, IP-54 containerized design
- C3 or C4 capable enclosure
- Multiple field-bus protocols

Benefits:

- Reduced operation and maintenance cost
- Fewer parts and increased reliability
- Global engineering and service organization

FLEX STORAGE – BESS

Key features:

- Grid integration and grid forming control, keeping pace with industry standards
- 40 kA medium voltage short-circuit withstand capability, simplifies substation design & procurement
- Up to 290 kA tested DC short circuit withstand
- Up to 150 kVA of customer auxiliary power & low voltage distribution built into FLEXINVERTER for simplified BESS container auxiliary power supply
- GPS accuracy for fault time stamping, compliant to CASIO & MISO requirements
- Revenue grade metering option

Benefits:

- Plug and play
- High availability
- Digital ready
- Capex saving features
- Grid forming and black start
- Dispatchable reactive power

FLEX SOLAR INVERTER – PV

Key features:

- Up to 1550 Vdc for optimized PV string layouts
- GPS accuracy for fault time stamping, compliant to CASIO and MISO requirements
- 40 kA medium voltage short-circuit withstand capability, simplifies substation design and procurement
- Grid integration and grid forming control, keeping pace with industry standards
- Revenue grade metering option
- Various ratings of customer auxiliary power

Benefits:

- Plug and play
- High availability
- Digital ready
- Capex saving features
- Grid forming and black start
- Dispatchable reactive power



About GE Vernova's Power Conversion & Storage business

GE Vernova's Power Conversion & Storage business combines advanced energy conversion and storage systems to meet the electrification needs of utilities and industries. With a focus on power stability, energy storage, and industrial electrification solutions, Power Conversion & Storage empowers customers by addressing their most complex electrification challenges and accelerating their transition to a sustainable, decarbonized future.

For more information, please visit
governova.com/power-conversion

Glossary

SFC	Static frequency converter
BESS	Battery energy storage systems
MMC	Modular multilevel converter
IGBT	Insulated gate bipolar transistors
SCADA	Supervisory control and data acquisition
MV	Medium voltage
LV	Low voltage
PV	Photovoltaic
EAF	Electric arc furnace

