



GE VERNOVA

# LARGE POWER INDUCTION MOTORS UP TO 40 MW

Our robust conventional speed technology is used in many industrial applications

**GE Vernova's Power Conversion & Storage business manufactured motors and generators for some of the first commercial and industrial electrical applications more than 125 years ago. We continue to deliver innovative electrical and mechanical power solutions to the world.**

Our machines operate efficiently in the most challenging applications and severe environments where reliability and ease of maintenance is critical.

Our induction motors are available up to 40 MW and are fully customizable to match our customers requirements at whatever speed, from the method of cooling to the smallest accessory.

GE Vernova's induction motors are highly reliable thanks to their rotor cage construction, the elimination of the retaining rings and they can be load tested at our factory. Our proprietary design allows for low vibration and high-power density.

## FEATURES & BENEFITS

### Compact design

- High power and torque density
- Footprint and weight reduced

### Customizable configuration

- Modular cooling system: CACA, CACW, TEPV, WPII, ODP
- Extreme environmental conditions: -40°C to +55°C ambient temperature, altitude > 1,000 m
- Safe and hazardous area
- Fixed speed 50/60 Hz
- Variable speed application – System approach for VSFS
- High load inertia starting
- Direct on line starting with limited voltage drop on the network (low inrush current)
- Compliance to high level specifications
- Compliance to international standards (IEC, API, NEMA, CSA, DNV, ABS, ...)

### Robust reliability

- Squirrel cage induction rotor with low maintenance
- Best in class induction brazing for uniform brazing of copper bar with end ring
- Improved insulation system to reduce partial discharge
- VPI with low Volatile Organic Compounds resin is applied to the complete stator and attached cables
- Full length slot wedges
- Removal stator core for simple stator replacement



# The advantage of induction motor technology

## 12 YEARS MTBF

Mean Time Between Failures

## DESIGNED FOR RAM

Reliability Availability Maintainability

## LOW VIBRATION

## HIGH POWER DENSITY

## FULLY CUSTOMIZABLE

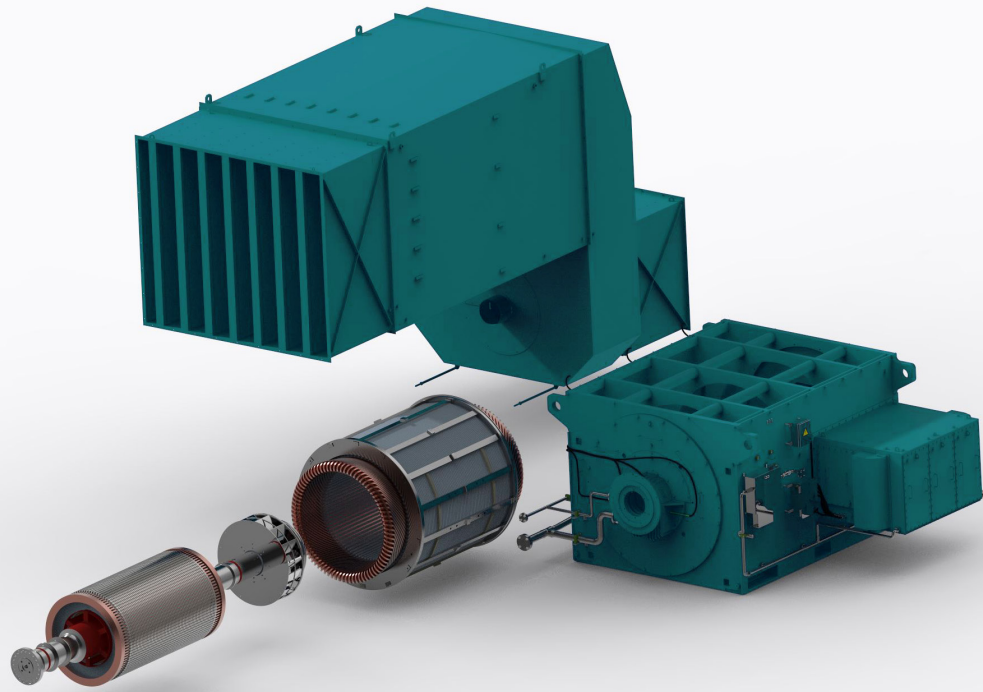

## A proven technology

Our induction motors come with a reference of 5,000 units and 20 GW power installed worldwide. Our technology is based on all our experience gained over the years in manufacturing electric motors and on 13 active patents related to general induction motors, like the Pin Vent Technology which reduces hot spot compared to I-beam technology.

## Decarbonization

- GE Vernova's high efficiency electrical motors help to reduce global carbon intensity for power generation
- Electrical technology also supersedes mechanical drivers in terms of lower carbon footprint

## POWER SPEED RANGE

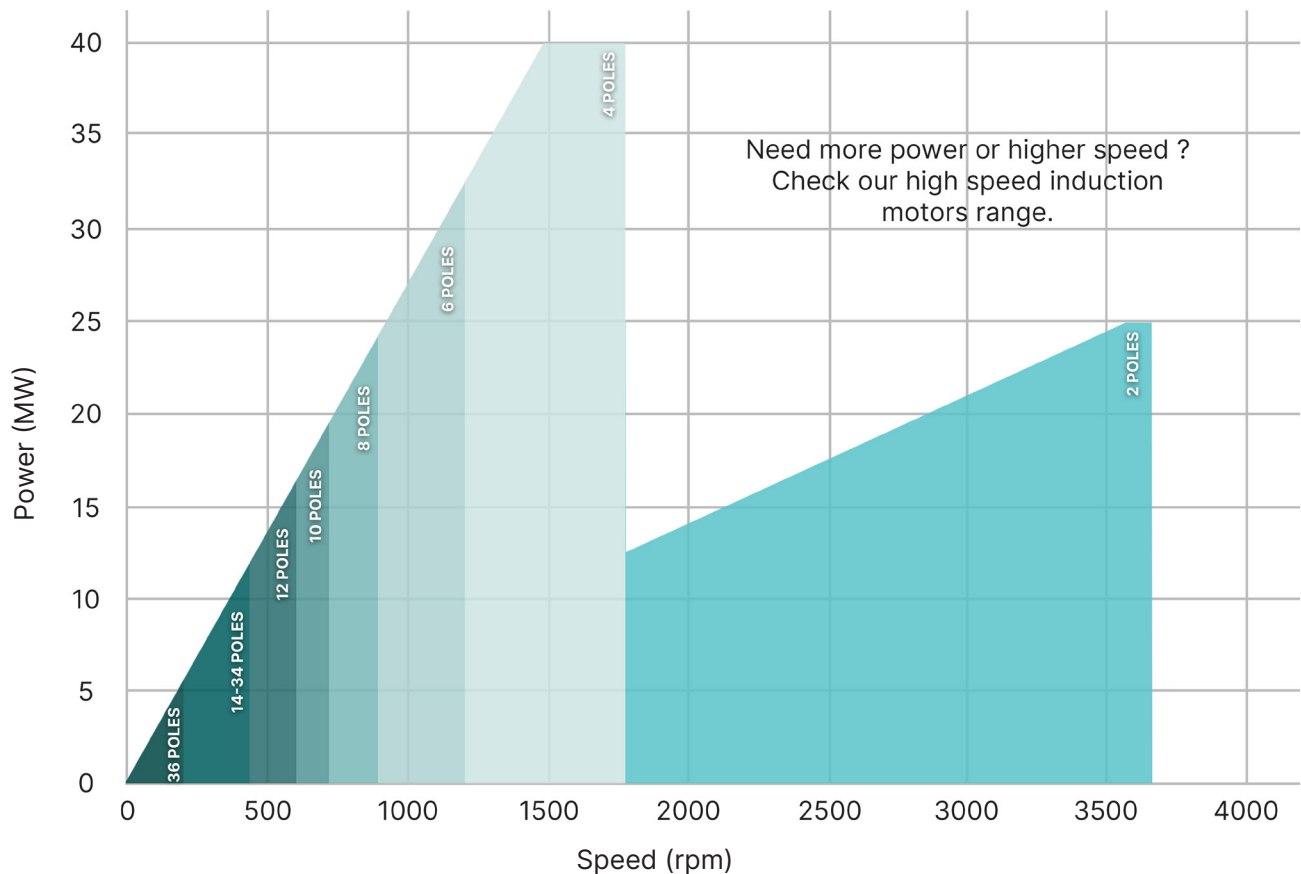

## Our services – a focus on availability

We understand the vital importance of process availability – and our focus on service keeps us actively engaged, both when things are going right, and when they are going wrong.

Our world-class Global Customer Service and Support Center is available 24/7, 365 days a year. Our strategic distribution centers and authorized distributors are there to ensure we will quickly fulfill your genuine replacement part needs, no matter where you are located.

With a comprehensive global network of service engineers and technicians, Power Conversion & Storage is uniquely positioned to provide the knowledge, experience, and skills for your full range of industrial service requirements. From system design to maintenance and outage support, we have the resources and capabilities to advance your equipment's performance and reliability.

We also provide managed system upgrade paths for our legacy systems and has significant experience in replacing systems from other manufacturers with low disruption to the existing infrastructure.

### Remote support

Power Conversion & Storage's Digital Suite is a remote diagnostic and support system based on highly secure satellite communications links. It enables our experts, regardless of their geographical location, to look over the shoulder of your onsite equipment operator or technician and advise and assist you on fault finding and resolution. We understand the vital importance of process availability – and our focus on service keeps us actively engaged, both when things are going right, and when they are going wrong. Through our Maintenance+ Service Agreements, we can continuously monitor health status of your assets and provide you on time solutions and advice for your imminent issues, before they happen.

## Overall system, project, and service capabilities

Our offerings cover each step of your project, namely conceptual design, engineering, manufacturing, equipment transportation and commissioning of the plant.

We will accompany you from the initial talks, system analysis, consulting, and sales pitches to the handover of the commissioned plant. From our perspective, overall system engineering (during planning phase) along with experienced project managers (during execution phase) are key to success – our system consultants work with you on finalizing the requirements and project managers coordinate the individual contractors, immediately perceive uprising challenges, and manage them in a structured and well organized manner.

### Productive Process Analysis

- Site survey & measurement
- Technical regulations compliance
- Rotating train productivity and efficiency study
- Service maintainability, availability and reliability study

### Integration and Testing

- Integration into existing customer site
- Type tests
- Factory acceptance tests and site acceptance tests
- Commissioning support, expert consulting & support

### Project and Service Support

- Product lifecycle management
- Up-time increase
- Remote monitoring & diagnostics
- Health checks
- Control modernization & upgrades
- On demand field services engineering support, evolving to system operation profiles & needs

## SOME KEY BENEFITS OF OUR SUPPORT ARE:

- Single point of contact
- Reduced call-out rates
- 24/7 availability
- Rapid mobilization of engineers
- Routine maintenance visits
- Training
- System health checks
- Spares management
- Obsolescence management

## About GE Vernova's Power Conversion & Storage business

GE Vernova's Power Conversion & Storage business combines advanced energy conversion and storage systems to meet the electrification needs of utilities and industries. With a focus on power stability, energy storage, and industrial electrification solutions, Power Conversion & Storage empowers customers by addressing their most complex electrification challenges and accelerating their transition to a sustainable, decarbonized future.

For more information, please visit  
[governova.com/power-conversion](https://governova.com/power-conversion)

