

HIGH SPEED INDUCTION MOTORS UP TO 100 MW



GE VERNOVA

Simply more reliable

Bringing industry electrification to the next level

With the continuous development of electrification in many industries around the world, Electric Motor Driven (EMD) solutions are now increasing in power and speed, offering new opportunities across multiple applications. Large EMD systems traditionally included large Load-Commutated Inverter (LCI) drives and synchronous motors. Several breakthroughs of innovation, such as the introduction of large power Voltage-Source Inverter (VSI) drives, have allowed to improve this configuration. GE Vernova has brought another layer of innovation with high speed induction motors up to 100 MW.

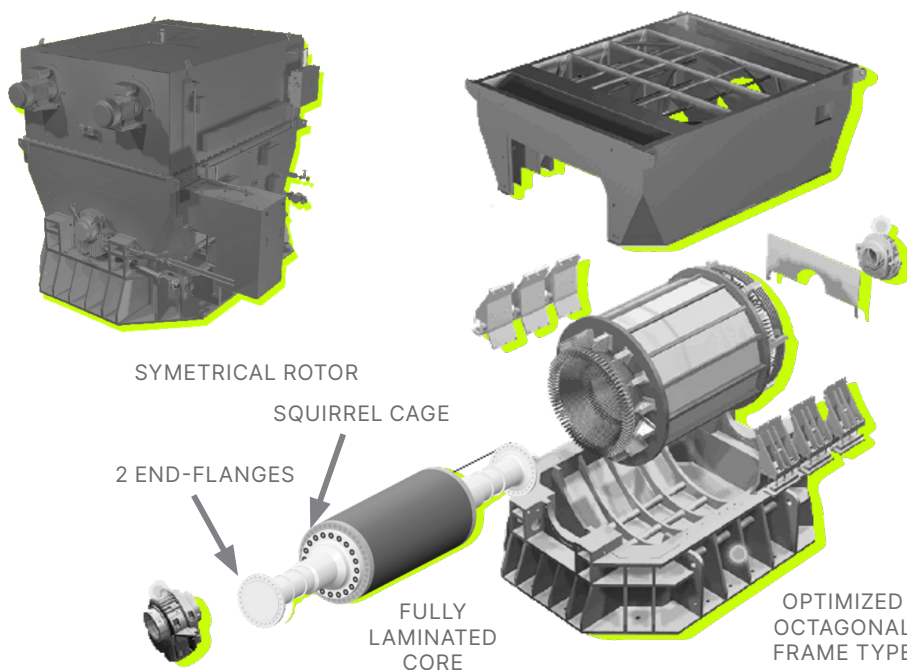

RELIABILITY

x 10

less rotating parts

EFFICIENCY

+98.1%

FOOTPRINT

Up to **-36%**

AVAILABILITY

Up to **+48%**
uptime

Comparison between traditional 2-pole synchronous and new induction technology

Source: GE Vernova's Power Conversion & Storage business' product leadership

Power and speed range

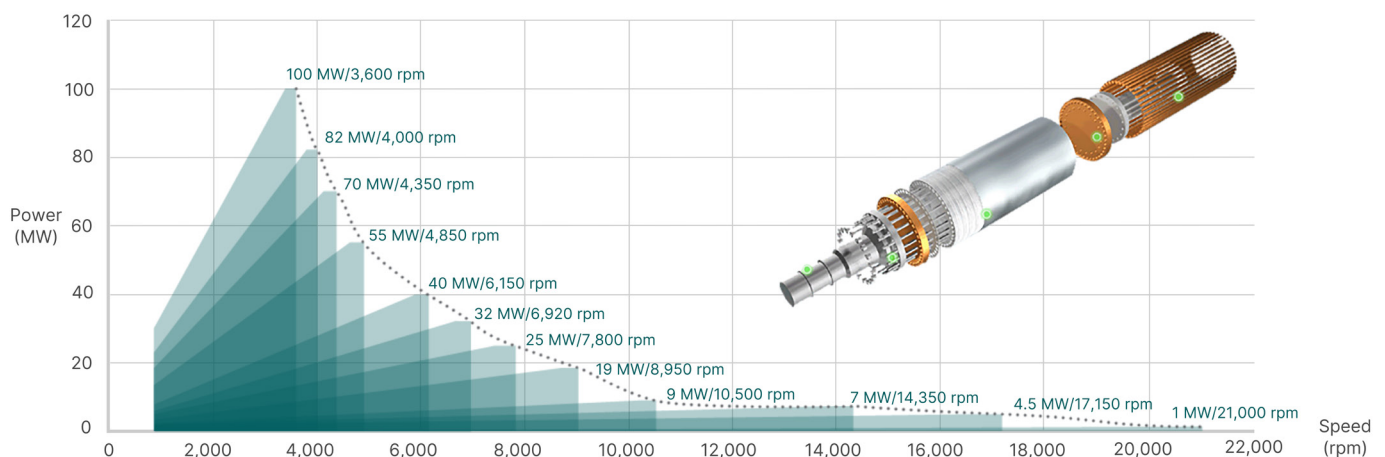

A solution offering advantages to the whole system*

Compared with traditional synchronous motors fed by LCI, our turbo induction motors fed by VSI offer many advantages:

Improved network stability and grid interaction

- Low harmonics content, network filter not required
- No risk of inter-harmonics
- Easy management of the network power factor even in case of network configuration change

Simplified compressor configuration

- Larger speed range and higher Maximum Continuous Speed (MCS), means more flexibility in compressor design, better efficiency and smaller compressors
- Reduced torque ripple at shaft level

More efficient process

- Higher speed and larger speed range for various applications such as test benches
- No need of separation margin with network frequency thanks to the absence of inter-harmonics
- Low vibration, stable when passing through the first critical speed, simpler rotor, reduced number of critical speeds (no exciter)
- Higher reliability and availability (up to +48% uptime) due to the simplicity of the rotor (non-insulated squirrel cage) and compactness of the motor

Reduced CAPEX

- Reduced filtering for high power applications
- Smaller compressor
- Smaller motor, with less equipment (ex: 10 times less rotating parts on the induction full laminated rotor compared to a synchronous rotor)
- Reduced and lighter supporting structure needed as the induction motor is more compact: smaller footprint (-30%), lower weight (-33%)

Reduced OPEX

- Higher drive-motor-compressor system efficiency, saving of 1% on energy consumption. For example, it can be evaluated at \$2.8 M for an 80 MW machine running full-time for 5 years
- Better power factor management, lower operating energy costs
- Less maintenance and less spare parts because of the simplicity of the induction motor

**For more details, please refer to IEEE Transactions on Industry Applications, May/June 2018 publication: "State of the art for full electric driven refrigeration compressors solutions using adjustable speed drive: Which combination of technology platforms leads to the best capex & opex solution up to 100 MW?"*

© 2025 GE Vernova. All rights reserved.

GE and the GE Monogram are trademarks of General Electric Company used under trademark license.

GEA33505A OG_FS_High-Speed-Induction-Motors-up-to-100-MW_20250526_Rev2



Proven technology

In 2018, GE Vernova tested the world's largest induction motor at 80 MW for the LNG industry.

80 MW induction motor key features

- Power: 80 MW
- Speed: 2,500 to 4,000 rpm
- Voltage: 11 kV
- Efficiency: 98.1%
- Weight: 150 tons (330,000 lbs)
- Footprint 4.5x6 m (15x20 ft)
- Cooling: Water cooled with auxiliary motor fan
- 2 oil lubricated sleeve bearings
- Squirrel cage laminated rotor
- No exciter needed
- Low noise < 90 dBA for such impressive power and speed
- Rotor vibrations <38 μ m peak-peak up to 4,800 rpm overspeed
- Endurance: 8 hours at critical speed, very stable rotor

GE VERNOVA'S ADVANTAGES

More than 150 high speed induction motors references worldwide, up to 80 MW and 18,000 rpm

15 patents on high-speed technology, among which include:

Optimized octagonal motor frame, less natural frequencies \Rightarrow no potential vibrations in the speed range 65-105%

Optimized stator air cooling, air ducts with optimized pins arrangement

Optimized squirrel cage with hybrid current transmission balancing from 0 rpm starting to full speed

Optimized rotor squirrel cage copper bars slots, improved power factor and better cooling

Fully laminated rotor with double coupling flanges