

MODELS PTG3-1-60 & PTG3-2-60

Indoor Voltage Transformer Medium Voltage



REGULATORY AGENCY APPROVALS



Manufactured to meet the requirements of ANSI/IEEE C57.13.
Classified by U.L. in accordance with IEC 44-1

Accuracy Class

0.3 WXYM, 1.2 Z at 100 % rated voltage with 120 V based ANSI burden.

0.6 WX, 1.2 MY at 58 % rated voltage with 69.3 V based ANSI burden.

Frequency

60 Hz.

Maximum System Voltage

5.6 kV, BIL 60 kV.

Thermal Rating

750 VA 30°C. amb.

500 VA 55°C. amb.

Approximate weight 34 lbs. unfused.

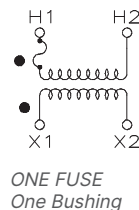
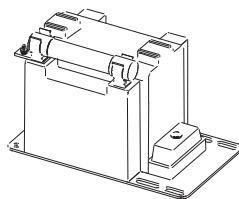
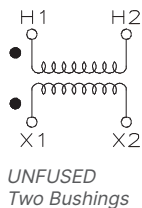
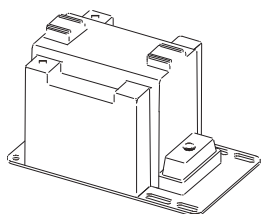

TWO FUSE
Two Bushing

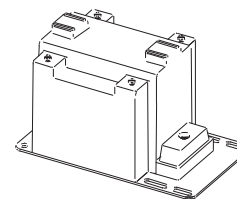

SWITCHGEAR
STYLE
Two Bushings

Product Data - PTG3

TWO BUSHINGS (a)					CATALOG NUMBERS		
GROUP	PRIMARY VOLTAGE	RATIO	SECONDARY VOLTAGE	UNFUSED	FUSES	FUSE CLIPS ONLY (d)	SWITCHGEAR STYLE
1	*2,400	20:1	120	PTG3-2-60-242	PTG3-2-60-242FF	PTG3-2-60-242CCS or CCL	PTG3-2-60-242SS
2	3,300	30:1	110-50 Hz	PTG3-2-60-332	PTG3-2-60-332FF	PTG3-2-60-332CCS or CCL	PTG3-2-60-332SS
2	*4,200	35:1	120	PTG3-2-60-422	PTG3-2-60-422FF	PTG3-2-60-422CCS or CCL	PTG3-2-60-422SS
2	*4,800	40:1	120	PTG3-2-60-482	PTG3-2-60-482FF	PTG3-2-60-482CCS or CCL	PTG3-2-60-482SS



ONE BUSHING (a)					CATALOG NUMBERS		
GROUP	PRIMARY VOLTAGE	RATIO	SECONDARY VOLTAGE	R _{FR} (c)	FUSES	FUSE CLIPS ONLY (d)	SWITCHGEAR STYLE
4A	*2,400	20:1	120	230	PTG3-1-60-242F	PTG3-1-60-242CS or CL	PTG3-1-60-242S
4B	*4,200	35:1	120	230	PTG3-1-60-422F	PTG3-1-60-422CS or CL	PTG3-1-60-422S
4B	*4,800	40:1	120	230	PTG3-1-60-482F	PTG3-1-60-482CS or CL	PTG3-1-60-482S

NOTE: All Primary voltages marked with an asterisk (*) are approved for revenue metering in Canada by Industry Canada, Approval No. T-215 Rev. 02

Models PTG3-1-60 & PTG3-2-60

Recommended Minimum Spacings

A = Unit to Unit = 0.75" minimum.

B = HV to Ground in air = 3.00" minimum.

Recommended spacing are for guidance only. User needs to set appropriate values to assure performance for high potential test, impulse test, high humidity, partial discharge, high altitude, and other considerations like configuration.

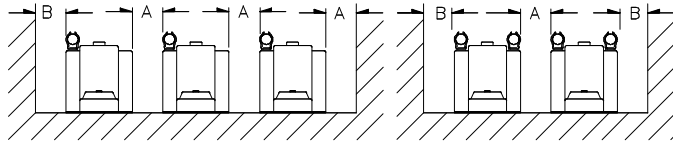

Circle Diagram

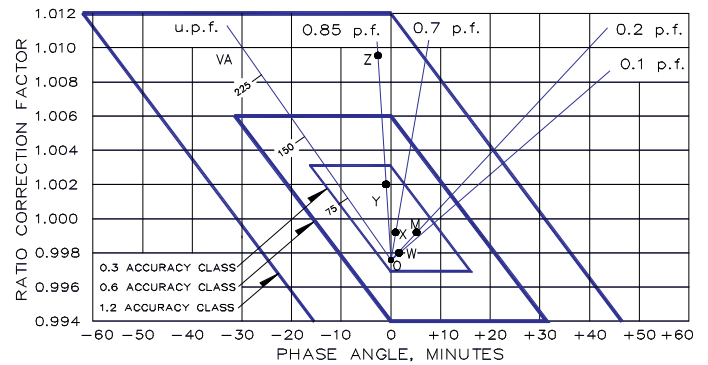

The circle diagram can be used to predict the performance of a transformer for various loads and power factors. A convenient scale of volt-ampere is shown on the unity power factor line (u.p.f) and commences at the zero or no-load locus. To use the diagram, measure the known V.A. and scribe an arc about the "Zero" locus of a length that contains the angle of the burden power factor. The point at which the arc terminates is the error locus in phase angle minutes and ratio correction factor.

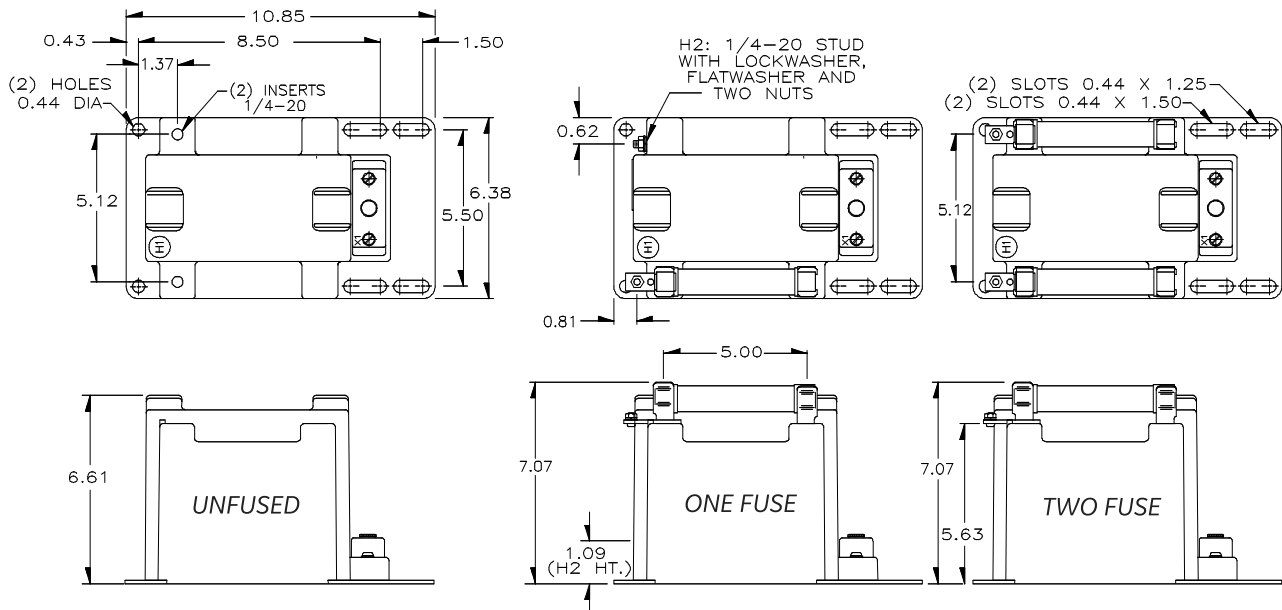

PTG3

FUSE FOR MODEL PTG3 TRANSFORMER	RATING VOLTS	INTERRUPTING AMPERES (SYM)	SUGGESTED RATING CONTINUOUS AMPERES	CAP DIA. INCHES (A)	LENGTH INCHES	CLIP CENTERS INCHES
2,400:120 V	5.5 kV	45,000	2.0 E	1.0	5.63	5.00
3,300:110 V	5.5 kV	45,000	2.0 E	1.0	5.63	5.00
4,200:120 V	5.5 kV	45,000	1.0 E	1.0	5.63	5.00
4,800:120 V	5.5 kV	45,000	1.0 E	1.0	5.63	5.00

Note: It is recommended that system line-to-line voltage not exceed the transformer maximum system voltage level.

(a) Two fuse transformers should not be used for Y connections. It is preferred practice to connect one lead from each voltage transformer directly to the neutral terminal, using a fuse in the line side of the primary only. By using this connection a transformer can never be made "live" from the line side by reason of a blown fuse in the neutral side. For continuous operation the transformer primary voltage should not exceed 110 % of rated value.

(b) Voltage transformers connected line-to-ground cannot be considered to be grounding transformers and must not be operated with the secondaries in closed delta because excessive currents may flow in the delta.

(c) See page 32, item 1 for ferroresonance considerations. Values in table are in ohms.

(d) Fuse clips noted as "CCS" or "CS" accept fuses with 1.0" Dia. caps and 5" clip centers. Fuses clips with a suffix "CCL" or "CL" accept fuses with 1.63" dia caps and 5.88" clip centers.

- Primary terminals are brass screws with one flatwasher and lockwasher.
- Secondary terminals are brass screws with one flatwasher and lockwasher.
- The core and coil assembly is vacuum encapsulated in polyurethane resin.
- A primary fuse is not supplied, but is recommended. Use a 25 kV, 0.5 E rated fuse for primary ratings of 13,000 volts or greater and 1.0 E for those rated less than 13,000 volts. A test card is provided with each unit.

For more information, visit
governova.com/grid-solutions

Instrument Transformers LLC reserve the right to change specifications of described products at any time without notice and without obligation to notify any person of such changes.

© 2025 GE Vernova and/or its affiliates. All rights reserved. GE and the GE Monogram are trademarks of General Electric Company used under trademark license.



GE VERNOVA

GEA-N50300
 English
 251023