

MODEL JVW-5A SUPERBUTE™

Outdoor Voltage Transformer

4,800 V to 14,400 V,
60 Hz, 110 kV BIL



Application

Model JVW-5A is a high accuracy voltage transformer designed for outdoor service. This model will meet IEEE C57.13.6 0.15 high accuracy class from 0 VA through the specified standard burden, from 90% to 110% of the rated voltage and is suitable for operating meters, instruments, relays, and control devices. This model is available in a variety of voltage, ratio and bushing types as outlined in the unit selection table below. Additional designs are available upon request. Rated Station Class with higher burden, thermal rating, and creep distance.

Features

- Thermal Rating: 2,000 VA (55 °C rise above 30 °C)
- Weight: 105 lbs (unit), 120 lbs (shipping)
- Dimensions: 16.88" (h) x 14.25" (w) x 13.05" (d)
- Creep Distance: 20.38" [517.7 mm]
- Strike Distance: 12" [305 mm]
- Insulation: HY-BUTE 60™ Butyl Rubber
- Insulation Class: 110 kV BIL, Outdoor
- Primary Winding Style: Lattice-Type
- Design Standard: IEEE C57.13
- Measurement Canada Approval: AE-2023

JVW-5A Unit Selection

RATED PRIMARY VOLTAGE	RATIO	IEEE ACCURACY CLASS, 60 Hz BURDEN ¹	CATALOG NUMBER
Single-Bushing ²			
7,200/12,470GY	60:1	0.15 W, X, M, Y	765X032051
8,400/14,560GY	70:1	0.15 W, X, M, Y	765X032052



JVW-5A Unit Selection (Cont'd)

RATED PRIMARY VOLTAGE	RATIO	IEEE ACCURACY CLASS, 60 Hz BURDEN ¹	CATALOG NUMBER
Double-Bushing³			
4,800/8,320Y	40:1	0.15 W, X, M, Y	765X032041
7,200/12,470Y	60:1	0.15 W, X, M, Y	765X032042
7,620/13,200Y	63.5:1	0.15 W, X, M, Y	765X032043
8,400/14,560Y	70:1	0.15 W, X, M, Y	765X032044
12,000/12,000Y	100:1	0.15 W, X, M, Y	765X032045
14,400/14,400Y	120:1	0.15 W, X, M, Y	765X032046

1. Voltage transformers of this type are available for use in 50 Hz applications for many ratings. However, IEEE C57.13 to which these transformers were designed and tested to does not apply to 50 Hz. When ordering voltage transformers for 50 Hz applications, provide an accuracy specification including Burden VA and Power Factor. If not specified, the transformer(s) will be tested per standard 60Hz test burdens.
2. Single bushing voltage transformers are suitable for application to grounded systems, for operation line-to-ground only. They will operate without damage connected line-to-ground at 1.40 times the transformer-rated voltage for one minute. If it should become necessary to apply these grounded units to an ungrounded system, please contact GE Vernova for application analysis.
3. Double bushing voltage transformers are suitable for operating line-to-line, line-to-ground or line-to neutral at a reduced voltage. The primary voltage under line-to-ground operation is the line-to-line voltage divided by√3, or approximately 58 %. Contact GE Vernova for accuracy rating at reduced operating voltage.

Wiring Diagrams

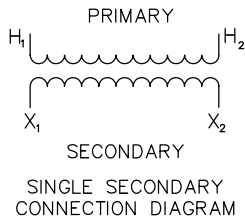

Typical Nameplate

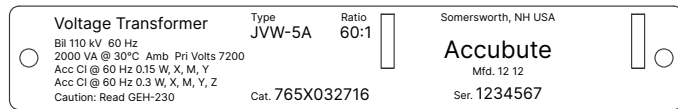

Reference Drawings & Accessories

Reference Drawings

- Accuracy Curve at 120 Secondary Volts, 60Hz - 9932600132
- Excitation Curve - 9932600134
- Outline Drawing - Single Bushing: 9935467
Double Bushing: 9935466

Accessories

- "L" Mounting Brackets - 8944634002
- Channel Bracket - 5466227001
- Suspensions Hooks - 8944630001
- Secondary Conduit Box - 9689897001

JVW-110 Selection Guide

PRODUCT CLASS	8.7 KV	15 KV	25 KV	35 KV	46 KV	69 KV
Station Class	JVW-4A	JVW-5A	JVS-150A	JVS-200A	JVS-250A	JVS-350A
			JVT-150A	JVT-200A	JVT-250A	JVT-350A
BIL	75 kV BIL	110 kV BIL	150 kV BIL	200 kV BIL	250 kV BIL	350 kV BIL
Accuracy, kVA Rating	0.15Y, 2 kVA	0.15Y, 2 kVA	0.15Z, 3 kVA	0.15Z, 3 kVA	0.15Z, 4.5-5 kVA	0.15Z, 4.5-5 kVA
Creep Distance	20.4" Creep	20.4" Creep	27-27.5" Creep	35-36" Creep	48-50" Creep	64-66" Creep
Net Weight	105 lbs	105 lbs	225-230 lbs	235-240 lbs	420 - 520 lbs	430-560 lbs
Distribution Class			JVW-6A	JVW-7A		
BIL			125-150 kV BIL	150-200 kV BIL		
Accuracy, kVA Rating			0.15X, 0.75 kVA	0.15X, 0.75 kVA		
Creep Distance			21" Creep	26.5" Creep		
Net Weight			105 lbs	140 lbs		

Single Bushing Dimension Drawing

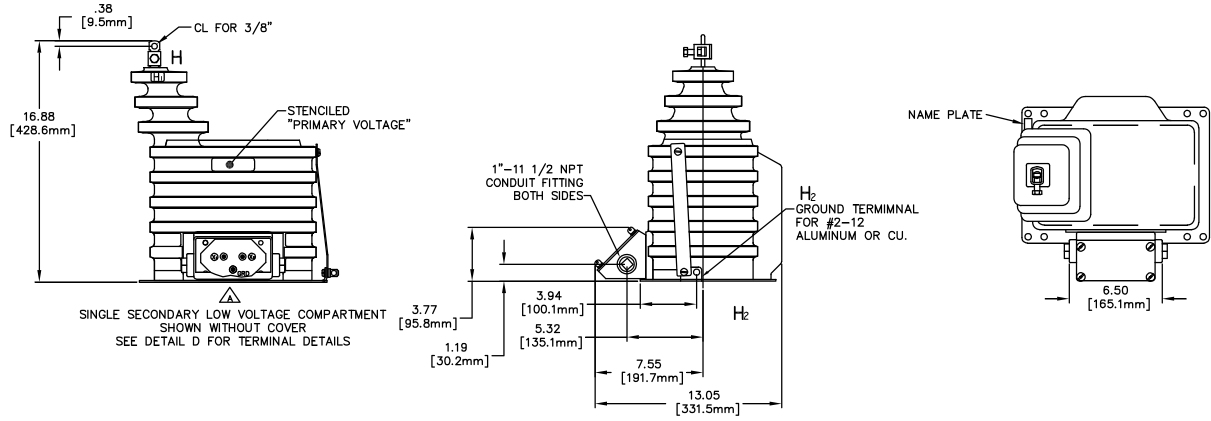

Two Bushing Dimension Drawing

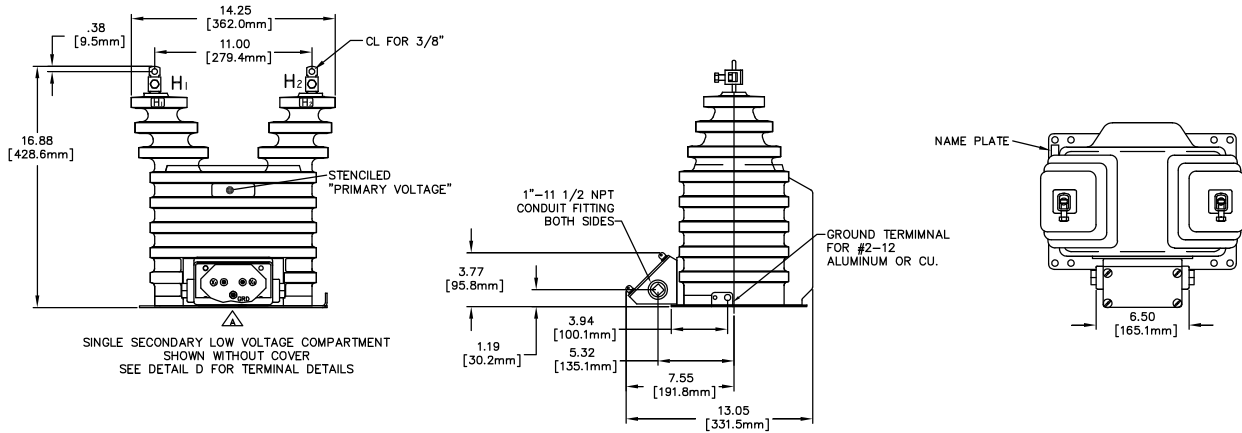

Mounting Plate Drawing

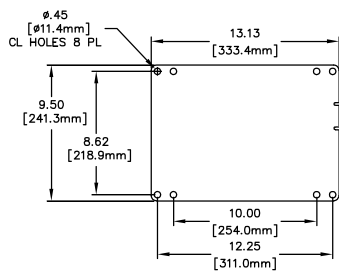

Secondary Terminal Configuration

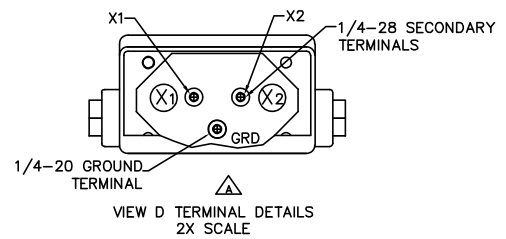

Construction Details

Insulation

The transformer design is constructed using GE Vernova's premium HY-BUTE™ 60 molded butyl rubber insulation for the transformer body. First introduced in 1955, GE Vernova's unique formulation is non-arc tracking and resistant to heat, chemicals, ozone and ultraviolet. This tough, resilient insulating material has proven to be superior in handling mechanical, electrical and environmental extremes, when compared against other insulation designs such as porcelain, urethane or epoxy.

Core & Coil

The internal primary windings are constructed with a LATTICE-type primary winding, originally patented by GE Vernova. The lattice-type design better distributes voltage stress across the windings, minimizes partial discharge, and maintains higher accuracy across the load range as compared to a traditional layer wound primary design. Outer electrostatic faraday shields act to further distribute steep voltage fronts across the coils. The finished primary coil is precast in epoxy resin prior to being molded in the outer HY-BUTE™ 60 insulation, for additional dielectric and mechanical strength. The core is made of high-quality silicon steel which is carefully selected, tested and annealed under rigidly controlled factory conditions. Enamel-insulated wire is used in both the primary and secondary coils.

Primary Terminals

The primary terminals are of the solder-less type. Made of hardened bronze, the terminal is fitted with a hard-copper collar and bronze pressure screw. The collar is semi-captive and may be turned 90-degrees in either direction for vertical or horizontal connection. With the collar in the vertical position, the maximum conductor sizes for copper are 250MCM and aluminum is 4/0. With the collar in the horizontal position, the maximum conductor sizes for copper are 3/0 and aluminum is 2/0. In either position, the minimum conductor size is AWG 10. A clearance hole for a 3/8 inch bolt is provided in the top of the terminal for additional flexibility in making connections. The complete terminal assembly is heavily electroplated with tin so that it is suitable for outdoor use.

Secondary Terminals

The secondary terminals are located on the insulated surface adjacent to the baseplate. These terminals are clamp-type in fixed, round tin-plated bronze posts, with excellent durability and corrosion resistance. They have a 0.275 inch diameter cross hole to accommodate large or multiple secondary wires. The secondary terminals are molded in the insulation and held in place internally by a terminal block that prevents their rotation.

Testing

Rigorous GE Vernova test requirements meet and exceed IEEE C57.13 routine requirements in order to ensure long term reliability. Test reports are saved electronically and can be e-mailed in various formats upon request.

Ground Terminal

A ground terminal is provided in the secondary compartment for making an optional connection to one of the secondary terminals. The 1/4-20 roundhead ground terminal is welded in the baseplate bracket, and is furnished with a nut, cup washer, flat washer, and lock washer.

Conduit Box

A detachable secondary conduit box is provided with the transformer. This die-cast aluminum conduit box is furnished attached to the transformer. Its use permits easy change out of transformers without dismantling rigid conduit structures. The box is provided with two 1 inch threaded conduit hubs on the sides and a 1 inch conduit knockout in the bottom. Each box is furnished complete with aluminum cover, gasket, four sealable cover screws, seal wire, four mounting screws with lock washers, and plastic pipe plugs.

Polarity

The permanently molded primary polarity markings H1 and H2 and the secondary polarity markings X1 and X2 are situated adjacent to their respective terminals. The polarity terminal is designated by use of the subscript 1, and the mark is painted white for better visibility.

Baseplate and Mounting

The base is made of stainless-steel. A stainless-steel grounding lug is welded to the baseplate and provides a hole for attaching the grounding connector. Mounting holes or slots are located in each corner of the baseplate. Mounting hardware is supplied with the transformer. The transformer can be mounted with the primary terminals in any position—up, down, or horizontal. It can be bolted directly to a cross-arm attached by "U" bolts or suspension hooks, or mounted on double cross-arms, using channel brackets.

Nameplate

The nameplate is made of stainless-steel and located on the base of the transformer. Information is per IEEE designation, laser-engraved for easy-to-read form. Custom barcoding available upon request.

Rating Identification

The high-voltage rating is identified by large orange digits located on the insulation surface near the top of the transformer. This provides permanent identification that is clearly visible from a distance, and is resistant to fading and abrasion.

Maintenance

These transformers require no maintenance other than an occasional cleaning if installed in an area where air contamination is severe.

For more information, visit
governova.com/grid-solutions

Instrument Transformers LLC reserve the right to change specifications of described products at any time without notice and without obligation to notify any person of such changes.

© 2025 GE Vernova and/or its affiliates. All rights reserved. GE and the GE Monogram are trademarks of General Electric Company used under trademark license.



GEA-N50625
English
251022