

MODEL JVP-1

Indoor Voltage Transformer

240 V to 600 V
BIL 30 kV, 50/60 Hz



Application

Designed for indoor service; suitable for operating meters, instruments, relays, and control devices.

Thermal Rating

55°C Rise Above 30 °C Ambient 750 VA
30°C Rise Above 50 °C Ambient 500 VA

Weight - Shipping/Net

(approximate, in pounds)
Unfused 35/30
With Two Primary Fuses 38/33

Reference Drawings

Accuracy Curve 9689241831

Outline Drawings:

Unfused with Primary Terminal
Bushing A9925192
Unfused with Primary Terminal
Cover A9925193
Two Fuse A9925195
Wiring Diagram refer to page 42, figure 5

Accessories - Catalog Number

Fuses; 5 A, 600 V 9F60AAA005
Secondary Terminal Conduit Box
..... 9925183001

JVM-95 Data Table

LINE-TO-LINE CIRCUIT VOLTAGE ⁽⁴⁾			TRANSFORMER RATING ⁽³⁾		ACCURACY CLASSIFICATION, 60 Hz		CATALOG NUMBER			FUSE 600 V CLASS
Δ ⁽¹⁾	Y ⁽²⁾	Y ONLY ⁽¹⁾	PRIMARY VOLTAGE	RATIO	BURDEN ⁽¹⁾	BURDEN W, X ⁽²⁾	UNFUSED PRIMARY TERMINAL		TWO FUSES, INDOOR USE	
							BUSHINGS	COVER		
240	240	416	240	2:1	0.3 W, X, M, V 1.2 Z	0.6	761X030001	761X030006	761X020001	5 A
-	-	480	288	2.4:1	0.3 W, X, M, V 1.2 Z	-	761X030002	761X030007	761X020002	5 A
-	-	480	300	2.5:1	0.3 W, X, M, V 1.2 Z	-	761X030003	761X030008	761X020003	5 A
480	480	-	480	4:1	0.3 W, X, M, V 1.2 Z	0.6	761X030004	761X030009	761X020004	5 A
600	600	-	600	5:1	0.3 W, X, M, V 1.2 Z	0.6	761X030005	761X030010	761X020005	5 A

Notes:

- Operated at rated voltage; secondary at 120 V.
- Operated at 58% of rated voltage; secondary at 69.4 V.
- For continuous operation, the transformer rated primary voltage should not be exceeded by more than 10%. Under emergency conditions, overvoltage must be limited to 1.25 times the transformer primary voltage rating.
- For Y connections, it is preferred practice to connect one lead from each voltage transformer directly to the grounded neutral, using a fuse only in the line side of the primary. By this connection a transformer can never be "alive" from the line side by reason of a blown fuse on the grounded side.

JVP-1 Voltage Transformer (Unfused)

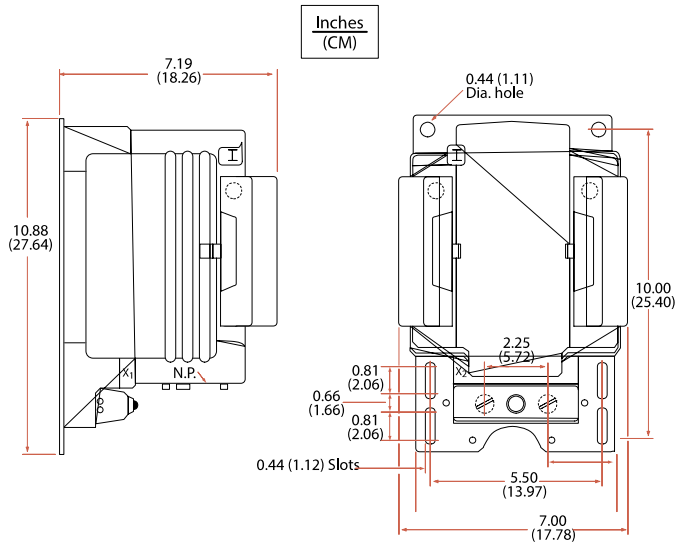

JVP-1 Voltage Transformer (Unfused)

Construction and Insulation

Please refer to General Product Information, items 1.2 and 1.8.

Core and Coils

The core is made of high quality grain-oriented silicon steel strip which is carefully selected, tested, and annealed under rigidly controlled conditions. It is wound into a rectangular shape to fit the coils. Both primary and secondary coils are layer wound and designed to give a low regulation to achieve high accuracy levels.

Primary Terminals

The primary terminals are located on the top of the transformer. They consist of 1/4 inch-20 screws, with lock washers and cup washers.

Unfused models are available with either a primary terminal cover or primary terminal bushings. The terminal cover is a sealable, molded-phenolic cover, which fits over the primary terminals to provide primary circuit insulation and to prevent tampering. When bushings are provided, the primary terminals are located on top of raised, cylindrical tapping bushings to improve ease of tapping the connection between the primary circuit conductors and the terminals. When primary terminal bushings are provided, a terminal cover cannot be accommodated.

On the two-fuse models, the primary terminals are attached directly to the fuse supports.

Fuse Covers

Fuse covers with seal tabs are furnished assembled on the two-fuse model of the JVP-1. These covers are molded of HY-BUTE I60 insulation.

Secondary Terminals

The secondary terminals are located at the lower front of the transformer, and are specifically designed to be accessible from the top of the transformer. The secondary terminals are 1/4 inch-20 screws with lock washers. The secondary terminal cover is molded of black phenolic resin, and is completely waterproof.

Conduit Box

A secondary terminal conduit box is available as an option in place of the standard secondary terminal cover. The conduit box and cover are made of corrosion-resistant, zinc-coated steel. The conduit box is fitted with two 1 inch conduit hubs, a 3/4 inch and 1 inch knockout, one pipe plug, polarity markers, and a gasketed cover, secured by four sealable captive thumbscrews.

Polarity

Please refer to General Product Information, item 7.1

Baseplate and Mounting

Please refer to General Product Information, item 5.1.

Nameplate

Please refer to General Product Information, item 6.9.

Maintenance

Please refer to General Product Information, item 10.1 and pages 24-27.

For more information, visit
governova.com/grid-solutions

Instrument Transformers LLC reserve the right to change specifications of described products at any time without notice and without obligation to notify any person of such changes.

© 2025 GE Vernova and/or its affiliates. All rights reserved. GE and the GE Monogram are trademarks of General Electric Company used under trademark license.



GEA-N50763
English
251009