

MODELS

JVM-4/JVM-5

Indoor Voltage Transformer

4,200 V to 14,400 V,
BIL 75 kV to 110 kV, 60 Hz

Application

Designed for indoor service; suitable for operating meters, instruments, relays, and control devices.

Regulatory Agency Approvals

UL Recognized File E178265

Thermal Rating

55°C Rise above 30°C Ambient..... 1,500 VA
30°C Rise above 55°C Ambient..... 1,000 VA



When choosing your GE Vernova Instrument Transformer, don't forget to explore the benefits of using GE Vernova's 0.15 accuracy class AccuBute line.

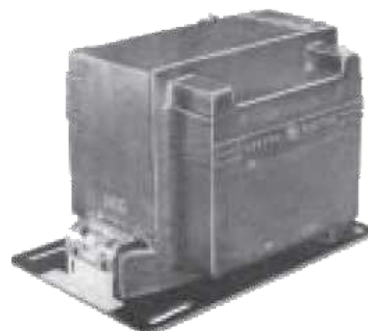

JVM-4, -5 Voltage Transformer
(unfused design)

ANSI Meter Accuracy Classification, 60 Hz

Operated at Rated Voltage
0.3 W, X, M, Y, Z; 1.2 ZZ.....Data Table - Accuracy 1
Operated at 58 % of Rated Voltage
0.3 W, X, M, Y; 1.2 Z..... Data Table - Accuracy 2
Burden Impedance as at Rated Voltage,
Operated at 58 % of Rated Voltage(2)
0.3 W, X; M, Y, Z' Data Table - Accuracy 3

JVM-4/JVM-5

LINE-TO-LINE CIRCUIT VOLTAGE FOR PERMISSIBLE PRIMARY CONNECTION			TRANSFORMER RATING ⁽¹⁾		ANSI ACCURACY CLASSIFICATION 60 Hz			BIL	CATALOG NUMBER SUPPLIED WITH FUSES ⁽⁸⁾	CATALOG NUMBER SUPPLIED WITHOUT FUSES ⁽⁸⁾	PRIMARY FUSE RATING	
Δ	Y	Y ONLY	PRIMARY VOLTAGE	RATIO	OPERATED AT RATED VOLTAGE	OPERATED AT 58% OF RATED VOLTAGE	BURDEN IMP AS AT RATED VOLTAGE; OPERATED AT 58% OF RATED VOLTAGE ⁽²⁾				Amps	Volts
Unfused - JVM-4												
4,200	4,200	7,200	4,200	35:1	Accuracy 1	Accuracy 2	Accuracy 3	75 kV	---	764X020001	---	---
4,800	4,800	8,320 ⁽³⁾	4,800	40:1	Accuracy 1	Accuracy 2	Accuracy 3	75 kV	---	764X020002	---	---
7,200	7,200	---	7,200	60:1	Accuracy 1	Accuracy 2	Accuracy 3	75 kV	---	764X020003	---	---
One Primary Fuse - JVM-4												
---	---	4,200	4,200 ⁽⁴⁾	35:1	---	Accuracy 2	Accuracy 3	75 kV	764X020021	---	2 A	4,800
---	---	7,200	4,200 ⁽⁷⁾	35:1	Accuracy 1	---	---	75 kV	764X020023	---	2 A	7,200
---	---	4,800	4,800	40:1	---	Accuracy 2	Accuracy 3	75 kV	764X020022	---	2 A	4,800
---	---	7,200	7,200	60:1	---	Accuracy 2	Accuracy 3	75 kV	764X020024	---	1 A	7,200
Two Primary Fuses - JVM-4												
4,200	---	4,200 ⁽³⁾	4,200 ⁽⁷⁾	35:1	Accuracy 1	Accuracy 2	Accuracy 3	75 kV	764X020012	---	2 A	4,800
---	---	7,200 ⁽³⁾	4,200	35:1	Accuracy 1	---	---	75 kV	764X020015	---	2 A	7,200
4,800	---	4,800 ⁽³⁾	4,800	40:1	Accuracy 1	Accuracy 2	Accuracy 3	75 kV	764X020013	---	2 A	4,800
7,200	---	7,200 ⁽³⁾	7,200	60:1	Accuracy 1	Accuracy 2	Accuracy 3	75 kV	764X020016	---	1 A	7,200
Unfused - JVM-5												
7,200	7,200	12,470	7,200	60:1	Accuracy 1	Accuracy 2	Accuracy 3	110 kV	765X021001	---	---	---
8,400	8,400	14,400	8,400	70:1	Accuracy 1	Accuracy 2	Accuracy 3	110 kV	765X021002	---	---	---
12,000	12,000	---	12,000	100:1	Accuracy 1	Accuracy 2	Accuracy 3	110 kV	765X021003	---	---	---
14,400	14,400	---	14,400	120:1	Accuracy 1	Accuracy 2	Accuracy 3	110 kV	765X021004	---	---	---
One Primary Fuse - JVM-5												
---	---	7,200	7,200 ⁽⁵⁾	60:1	---	Accuracy 2	Accuracy 3	110 kV	765X021053	765X021061	1 A	7,200
---	---	12,470	7,200	60:1	Accuracy 1	---	---	110 kV	765X021048	765X021056	1 A	14,400
---	---	14,400	8,400	70:1	Accuracy 1	---	---	110 kV	765X021049	765X021057	1 A	14,400
---	---	12,000	12,000	100:1	---	Accuracy 2	Accuracy 3	110 kV	765X021050	765X021058	0.5 A	14,400
---	---	14,400	14,400	120:1	---	Accuracy 2	Accuracy 3	110 kV	765X021051	765X021059	0.5 A	14,400
Two Primary Fuses - JVM-5												
7,200	---	7,200 ⁽³⁾	7,200 ⁽⁶⁾	60:1	Accuracy 1	Accuracy 2	Accuracy 3	110 kV	765X021031	765X021047	1 A	7,200
7,200	7,200	12,470 ⁽³⁾	7,200	60:1	Accuracy 1	---	---	110 kV	765X021027	765X021043	1 A	14,400
8,400	8,400	14,400 ⁽³⁾	8,400	70:1	Accuracy 1	Accuracy 2	Accuracy 3	110 kV	765X021028	765X021044	1 A	14,400
12,000	---	12,000 ⁽³⁾	12,000	100:1	Accuracy 1	Accuracy 2	Accuracy 3	110 kV	765X021029	765X021045	0.5 A	14,400
14,400	---	14,400 ⁽³⁾	14,400	120:1	Accuracy 1	Accuracy 2	Accuracy 3	110 kV	765X021030	765X021046	0.5 A	14,400

Notes:
 (1) For continuous operation, the transformer-rated primary voltage should not be exceeded by more than 10 %. Under emergency conditions, over-voltage must be limited to 1.25 times the transformer primary-voltage rating.
 (2) Operated at 58 % of Rated Voltage; the prime symbol (') is used to signify that these burdens do not correspond to standard ANSI definitions.
 (3) For Y connections, it is preferred practice to connect one lead from each voltage transformer directly to the grounded neutral, using a fuse only in the line side of the primary. By this connection a transformer can never be "alive" from the line side by reason of a blown fuse on the grounded side.
 (4) This transformer is similar to Catalog Number 764X020023 except for the voltage rating of the fuse.
 (5) This transformer is similar to Catalog Number 765X021048 except for the voltage rating of the fuse.
 (6) This transformer is similar to Catalog Number 765X021027 except for the voltage rating of the fuse.
 (7) This transformer is similar to Catalog Number 764X020015 except for the voltage rating of the fuse.
 (8) Measurement Canada Approval: AE-0853 or AE-0314

JVM-4/JVM-5 Dimensions

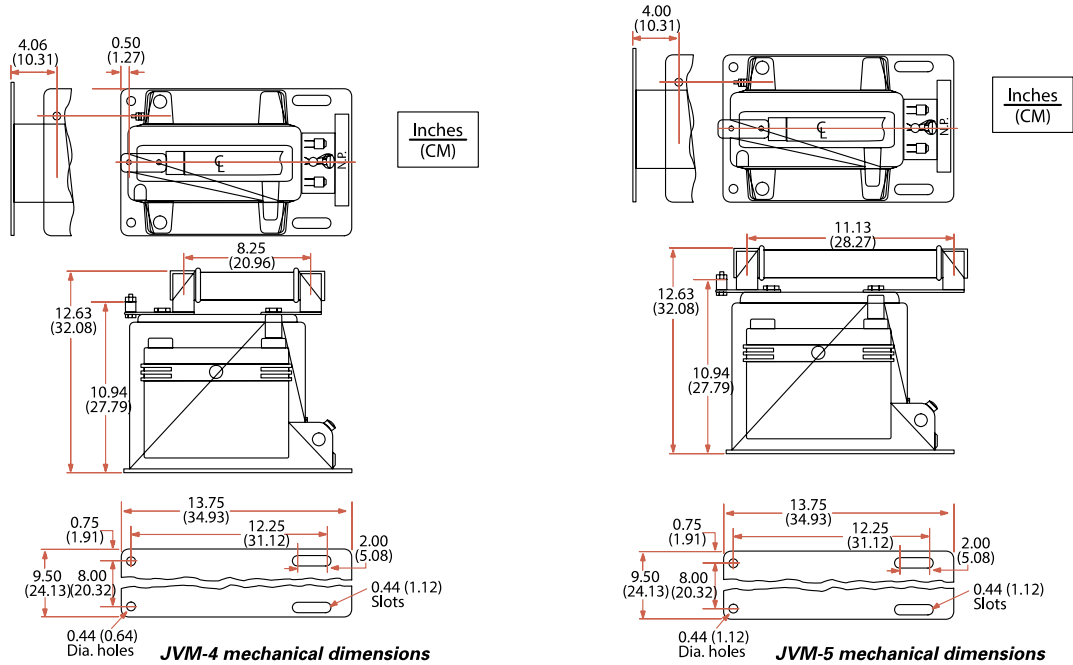

Weight - Shipping/Net

(approximate, in pounds)

Unfused	105/85
With fuses	110/90
Reference Drawings	
Accuracy Curve.....	9689241655
Excitation Curves:	
60:1 and 70:1	9689241591
100:1 and 120:1.....	9689241629
Outline Drawings:	
JVM-4	
Unfused Models.....	8949818
One Fuse Models	8949938
Two Fuse Models	8949820
JVM-5	
Unfused Models.....	8949818

One Fuse Models:

Model 765X021053 only.....	8949938
All except Model 756X021053	8949939

Two Fuse Models:

Model 765X021031 only	8949825
All except Model 765X021031.....	8949824
Wiring Diagram.....	refer to page 42, figure 5
Accessories	Catalog Number

Fuses, Current-limiting, Type EJ-1:

4,800 Volt Class, 2 Ampere.....	9F60BDD002
7,200 Volt Class, 1 Ampere.....	9F60BDE001
7,200 Volt Class, 2 Ampere	9F60BDE002
14,400 Volt Class, 0.5 Ampere.....	9F60BHH905
14,400 Volt Class, 1 Ampere	9F60BHH001

Construction and Insulation

Please refer to General Product Information, item 1.4.

Core

Please refer to General Product Information, item 2.3.

Primary and Secondary Coils

Please refer to General Product Information, item 3.2

Primary Terminals

Please refer to General Product Information, item 4.2.

Fuses

Current-limited, Type EJ-1 fuses are used.

Secondary Terminals

Please refer to General Product Information, item 4.12.

Polarity

Please refer to General Product Information, item 7.2.

Baseplate and Mounting

Please refer to General Product Information, item 5.5.

Nameplate

Please refer to General Product Information, item 6.5.

Maintenance

Please refer to General Product Information, item 10.1 and pages 24-27.

Note:

1. Voltage transformers of this type are available for use in 50 Hz applications in many ratings. However, Industry Standard IEEE 57.13 to which we test transformers does not apply at 50 Hz. Customers who order voltage transformers for 50 Hz application should provide an accuracy specification including Burden VA and Power Factor. If an accuracy specification is not made available, the transformer(s) will be tested at 60 Hz with test burdens as defined in IEEE 57.13 for 60 Hz application.

For more information, visit
governova.com/grid-solutions

Instrument Transformers LLC reserve the right to change specifications of described products at any time without notice and without obligation to notify any person of such changes.

© 2025 GE Vernova and/or its affiliates. All rights reserved. GE and the GE Monogram are trademarks of General Electric Company used under trademark license.



GE VERNOVA

GEA-N50277
English
251023