

MODEL JKW-7ER SUPERBUTE™

Outdoor Current Transformer

NSV 34.5 kV, 200 kV BIL,
2 to 1250A, 50/60 Hz



Application

Model JKW-7ER is a SUPERBUTE™ butyl rubber instrument transformer, specially designed for longer life and higher reliability, and is part of GE Vernova's RevenueSense™ line of high accuracy, extended range revenue metering current transformers which maintain IEEE C57.13 0.15 accuracy class from 1% of rated current up through rating factor. This is accomplished using a specialized core material which minimizes electrical core losses. The result is an extremely accurate CT that can maintain high accuracy over an extended range of current. Designed for outdoor service; suitable for revenue metering applications.

Features

- Weight: 60 lbs (unit), 75 lbs (shipping)
- Dimensions: 19.88" (h) x 10.88" (w) x 9.51" (d)
- Creep Distance: 27.62" [701.5 mm]
- Strike Distance: 16.53" [420 mm]
- Insulation: HY-BUTE 60" Butyl Rubber
- Insulation Class: 200 kV BIL, Outdoor
- Design Standard: IEEE C57.13
- Approved for revenue metering by Measurement Canada AE-2465

Key Benefits

- Maximize revenue metering accuracy with special high accuracy rating extended beyond IEEE requirements
- Simplify CT selection and billing multipliers, improving productivity and minimizing risk of error
- Reduce inventory and part number requirements, reducing asset and operational costs

0.15 Class - High Accuracy

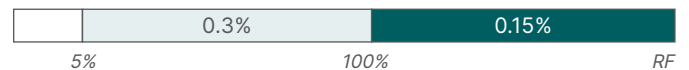

0.15S Class - Special High Accuracy



GE Vernova RevenueSense™

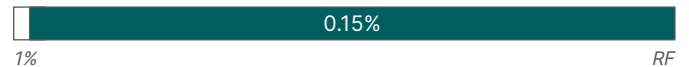

Unit Selection

CURRENT RATIO	METERING CLASS	RF ²	MECHANICAL LIMIT	1-Sec THERMAL LIMIT, A	VOLTAGE CLASS kV	CATALOG NUMBER
250:5	0.15S80.5 ¹	1.5	66,600	45,000	34.5	757X058002
1000:5	0.15S80.5 ¹	1.25	100,000	60,000	34.5	757X058001

⁽¹⁾ Exceeds IEEE definition for special high accuracy. Maintains 0.15 Accuracy from 1% to Rating Factor

⁽²⁾ "RF" is defined as Continuous Thermal Rating Factor at 30°C, ambient



Dimensions, Mounting and Wiring Diagram

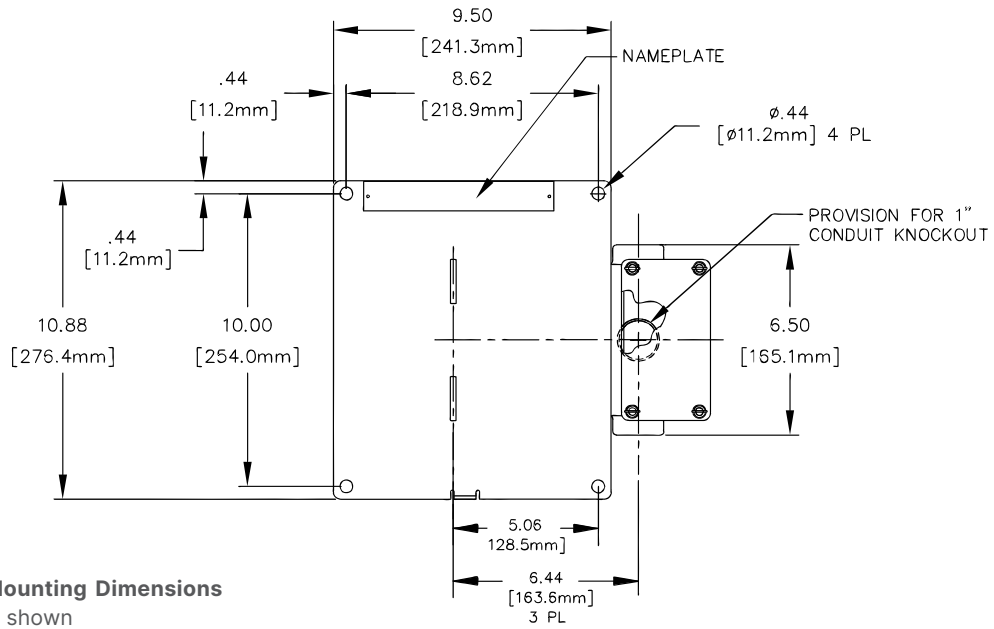
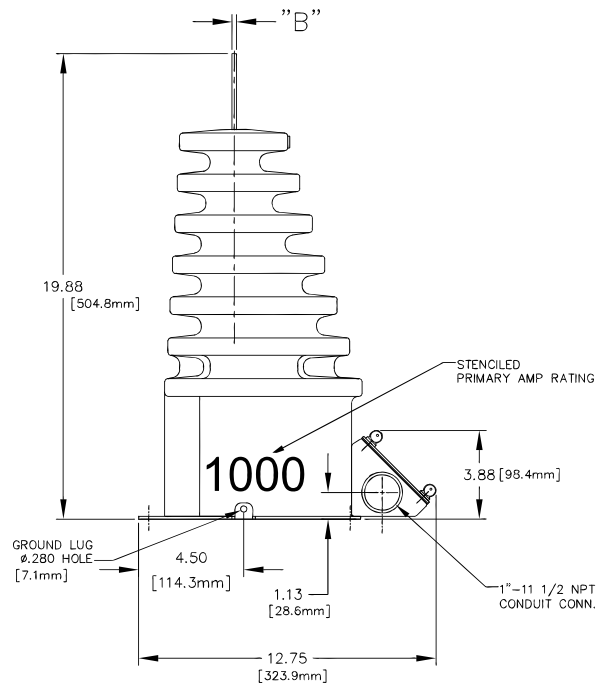

Based Mounting Dimensions
Butyl not shown

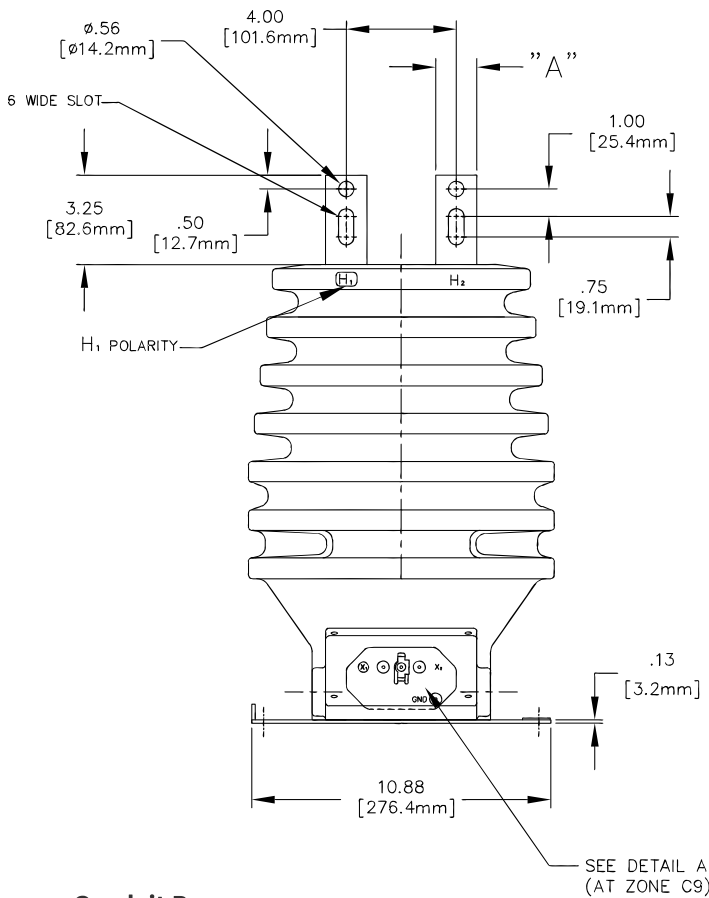

RATED CURRENT A	"A" IN Inches (mm)	"B" IN Inches (mm)
10 to 150	1.50 (38.1)	0.18 (4.8)
200	2.00 (50.8)	0.25 (6.4)
300 to 1000	2.00 (50.8)	0.38 (9.5)

Table 1

Conduit Box
Cover removed for clarity

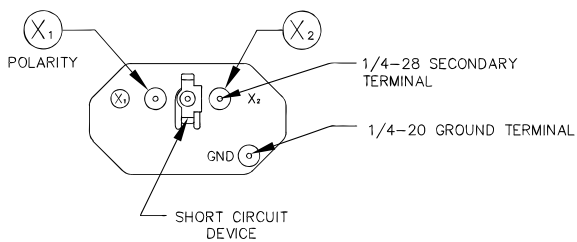

DETAIL A
SINGLE Secondary Terminal Details

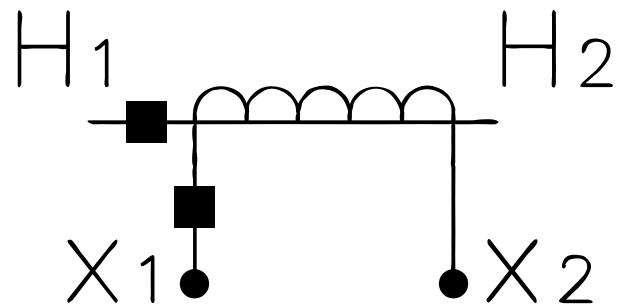

Single secondary connection diagram

Construction Details

Insulation

The transformer design is constructed using GE Vernova's premium HY-BUTE 60 molded butyl rubber insulation for the transformer body. First introduced in 1955, GE Vernova's unique formulation is non-arc tracking and resistant to heat, chemicals, ozone and ultraviolet. This tough, resilient insulating material has proven to be superior in handling mechanical, electrical and environmental extremes, when compared against other insulation designs such as porcelain, urethane or epoxy.

Core and Coils

The core is manufactured with high-efficiency material that reduces energy losses, allowing for higher accuracy over a wider range.

Windings

The primary winding consists of strip wound copper in a circular pattern for the lower ratings, and a single-turn configuration for the higher ratings. This type of construction provides good accuracy, along with the highest fault current withstand characteristics. The secondary winding is made of enamelinsulated copper wire, evenly distributed around the core. This construction reduces leakage flux and provides the best possible accuracy.

Primary Terminals

The primary terminals are flat copper bars, each with one bolt hole and a slot, which facilitates connections to various size cable lugs. The terminal surfaces are tin-plated to reduce contact resistance, and to allow connection to either copper or aluminum conductors.

Secondary Terminals & Conduit Box

The secondary terminals are clamp-type, with a 0.275-inch diameter hole, simplifying the connection of large or multiple secondary wires. The terminals are located on the front of the transformer on the flat butyl surface adjacent to the baseplate. The terminals are made of bronze for excellent durability and corrosion resistance. An internal secondary terminal block secures the secondary terminals, as well as a stud in between the two terminals, which is used as a short-circuit device pivot. The short-circuit device is simple, easy to operate, and is made of sturdy bronze parts to give the highest reliability. It features a large contact area, with the short-circuit device and a slot in the terminal having parallel faces to make and extremely good electrical contact. The contact with the terminal is direct, thus eliminating additional joints or connections.

Testing

Rigorous GE Vernova test requirements go beyond ANSI/IEEE routine requirements in order to ensure long term reliability. Test reports are saved electronically and can be e-mailed in various formats upon request.

Ground Terminal

A ground terminal is provided in the secondary compartment for making an optional connection to one of the secondary terminals. The 1/4-20 round-head ground terminal is welded in the baseplate bracket, and is furnished with a nut, cup washer, flat washer, and lock washer.

Polarity

The primary and secondary polarity markers are molded in the insulation. They are thus permanent and integral parts of the transformer and cannot readily be obliterated. The polarity is subtractive.

Baseplate and Mounting

The base is made of stainless-steel. A stainless-steel grounding lug is welded to the baseplate and provides a hole for attaching the grounding connector. Mounting holes or slots are located in each corner of the baseplate. Mounting hardware is supplied with the transformer. The transformer can be mounted with the primary terminals in any position - up, down, or horizontal. It can be bolted directly to a crossarm attached by "U" bolts or suspension hooks, or mounted on double crossarms, using channel brackets. Refer to the Accessories Listing on the transformer data sheet for Catalog Numbers.

Nameplate

The nameplate is made of anodized aluminum and located on the base of the transformer. Information is per IEEE designation, laser-engraved for easy-to-read form. Custom barcoding available upon request.

Rating Identification

The primary current rating is identified by large orange digits located on two sides of the transformer. This provides permanent identification that is clearly visible from a distance and is resistant to fading and abrasion.

Maintenance

These transformers require no maintenance other than an occasional cleaning if installed in an area where air contamination is severe.

For more information, visit
[governova.com/grid-solutions](https://www.governova.com/grid-solutions)

Instrument Transformers LLC reserve the right to change specifications of described products at any time without notice and without obligation to notify any person of such changes.

© 2025 GE Vernova and/or its affiliates. All rights reserved. GE and the GE Monogram are trademarks of General Electric Company used under trademark license.



GEA-N50412
English
251022