

MODEL JKW-6A SUPERBUTE™

Outdoor Current Transformer

25,000 V, 5 A to 1,200 A,
50/60 Hz, 150 kV BIL



Application

Designed for outdoor service; suitable for operating meters, relays, and control devices. Features 0.15 accuracy from 5% of nameplate amps through rating factor within burden capability. Available in a variety of ratio as outlined in the unit selection table below, with additional designs available upon request.

Features

- Weight: 75 lbs (unit), 85 lbs (shipping)
- Dimensions: 15.94" (h) x 10.88" (w) x 12.38" (d)
- Creep Distance: 24" [609.6 mm]
- Strike Distance: 12.51" [318 mm]
- Insulation: HY-BUTE 60TM Butyl Rubber
- Insulation Class: 150 kV BIL, Outdoor
- Design Standard: IEEE C57.13

Reference Drawings & Accessories

Accuracy Curve(s) at 60 Hz

- 5 A to 600 A & 1,200 A - 9932600141
- 800 A - 9932600152

Excitation Curve(s)

- 5 A to 600 A, and 1,200 A 9932600142
- 800 A 9932600153

Accessories

- "L" Mounting Brackets 8944634002
- Channel Bracket 5466227001
- Suspension Hooks 8944630001
- Secondary Conduit Box 9689897001



Unit Selection JKW-6A

CURRENT RATIO	METER CLASS	RF ¹	MECHANICAL LIMIT, Amps	1-Sec THERMAL LIMIT, Amps	CATALOG NUMBER ²
5:5	0.15S B0.5	1.5	925	500	756X051021
10:5	0.15S B0.5	1.5	1,850	1,000	756X051022
15:5	0.15S B0.5	1.5	2,775	1,500	756X051023
20:5	0.15S B0.5	1.5	3,700	2,000	756X051024
25:5	0.15S B0.5	1.5	4,625	2,500	756X051025
50:5	0.15S B0.5	1.5	9,250	5,000	756X051026
75:5	0.15S B0.5	1.5	9,375	7,500	756X051027
100:5	0.15S B0.5	1.5	12,500	10,000	756X051028
150:5	0.15S B0.5	1.5	18,750	15,000	756X051029
200:5	0.15S B0.5	1.5	18,750	20,000	756X051030
300:5	0.15S B0.5	1.5	37,500	30,000	756X051031
400:5	0.15S B0.5	1.5	50,000	40,000	756X051032
600:5	0.15S B0.5	1.5	75,000	60,000	756X051033
800:5	0.15S B0.5	1	100,000	80,000	756X051034
1,200:5	0.15S B0.5	1	150,000	120,000	756X051035

1. "RF" is defined as Continuous Thermal Rating Factor at 30 °C, ambient

2. Measurement Canada Approval: AE-0817

Selection Guide JKW-3

PRODUCT CLASS	5 kV	8.7 kV	15 kV	25 kV	35 kV	46 kV	69 kV
Station Class	JKW3A	JKW4A	JKW5A	JKW150A	JKW200A	JKW250A	JKW350A
				JKW150ER	JKW200ER	JKW250ER	JKW350ER
BIL	60 kV BIL	75 kV BIL	110 kV BIL	150 kV BIL	200 kV BIL	250 kV BIL	350 kV BIL
Accuracy, Rating Factor*	0.15SB0.5, RF 1.5	0.15SB0.5, RF 1.5	0.15SB0.5, RF 1.5	0.15SB1.8, RF 1.5	0.15SB1.8, RF 1.5	0.15SB1.8, RF 1.5	0.15SB1.8, RF 1.5
Creep Distance	12.5" Creep	12.5" Creep	24" Creep	44.1" Creep	56.6" Creep	71.0" Creep	86.6" Creep
Net Weight	40 lbs	40 lbs	60 lbs	323 lbs	348 lbs	543 lbs	593 lbs
Distribution Class				JKW6			
BIL				150 kV BIL			
Accuracy, Rating Factor*				0.15SB0.5, RF 1.5			
Creep Distance				24" Creep			
Net Weight				80 lbs			

Dimensions, Mounting & Wiring Diagram

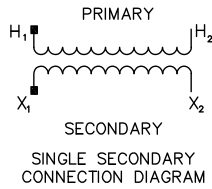
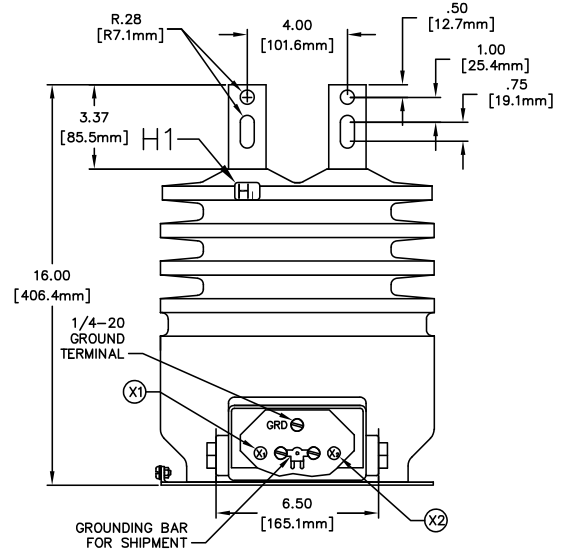
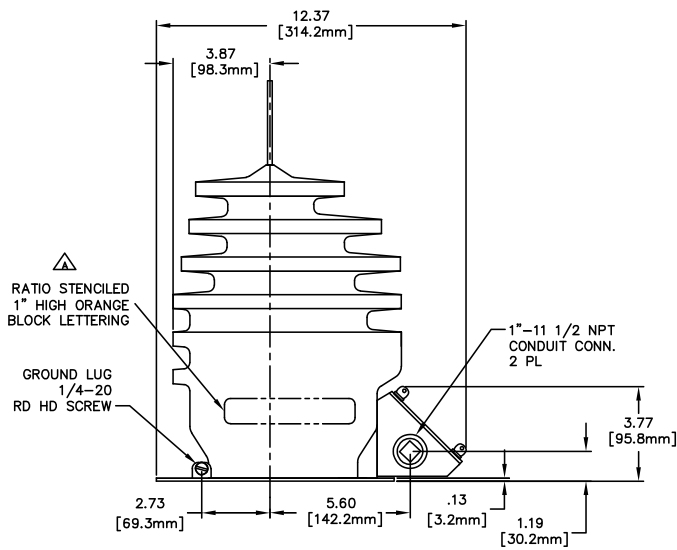

H1/H2 TERMINAL DIMS		
AMPS	A	B
5 TO 75	1.5 (1.38MM)	.19 (4.8MM)
100 TO 200	2 (50.8MM)	.25 (6.4MM)
300 TO 800	2 (50.8mm)	.38 (9.5mm)

Typical Nameplate

<p>Current Transformer</p> <p>Bil 150 kV NSV 25 kV 60Hz RF = 1.5 @ 30°C Amb Acc CI @ 60 Hz 0.15 E-0.04, 0.15S B-0.1 THRU B-0.5, 0.3 B-1.8, T200</p> <p>Caution: Read GEH-230</p>	<p>Type JKW-6A</p>	<p>Ratio 10:5 Amp</p>	<p>Somersworth, NH USA</p> <p>Accubute</p> <p>APPR# AE-0817 Mfd. 11 14 Ser. 7364688</p>
Cat. 756X051022			

Construction Details

Insulation

The transformer design is constructed using GE Vernova's premium HY-BUTE 60 molded butyl rubber insulation for the transformer body. First introduced in 1955, GE Vernova's unique formulation is non-arc tracking and resistant to heat, chemicals, ozone and ultraviolet. This tough, resilient insulating material has proven to be superior in handling mechanical, electrical and environmental extremes, when compared against other insulation designs such as porcelain, urethane or epoxy.

Core & Coil

The core is made of high-permeability, formed, silicon steel strip. The steel is characterized by having highly directional properties, that is, low core losses and high permeability in the direction of rolling. Full advantage is taken of this property of the steel by the shape and construction of the core. The core has a dispersed-gap construction with interleaved laminations. This type of core provides a construction that will not shift to cause any change in the transformer characteristics. After being assembled into the coils, the core is securely clamped and permanently fastened to the base plate by a heavy steel strap which encircles the core and is welded to the base.

Windings

The primary winding consists of two coils connected in series. Each coil surrounds one leg of the core. This design reduces leakage losses, thus improving the accuracy of the transformer. It also provides a higher mechanical strength than a single coil construction. The secondary winding consists of two coils connected in parallel. Each coil is located inside the corresponding primary coil and surrounds one leg of the core.

Primary Terminals

The primary terminals are flat copper bars, each with one bolt hole and a slot, which facilitates connections to various size cable lugs. The terminal surfaces are tin-plated to reduce contact resistance, and to allow connection to either copper or aluminum conductors.

Secondary Terminals & Conduit Box

The secondary terminals are in a compartment molded in the side of the transformer. The compartment has a molded phenolic cover held by four brass, nickel-plated, captive thumbscrews, which engage a metal insert molded in the rubber. The thumbscrews are drilled to accommodate a seal wire. The compartment also has two openings for 1 inch conduit connection. The secondary terminals are the threaded type, each with cup washer, lock washer and nut. A manually operated, secondary short-circuiting switch is located between the secondary terminal studs.

Testing

Rigorous GE Vernova test requirements go beyond ANSI/IEEE routine requirements in order to ensure long term reliability. Test reports are saved electronically and can be e-mailed in various formats upon request.

Ground Terminal

A ground terminal is provided in the secondary compartment for making an optional connection to one of the secondary terminals. The 1/4-20 roundhead ground terminal is welded in the baseplate bracket, and is furnished with a nut, cup washer, flat washer, and lock washer.

Polarity

The primary and secondary polarity markers are molded in the insulation. They are thus permanent and integral parts of the transformer and cannot readily be obliterated. The polarity is subtractive.

Baseplate and Mounting

The base is made of stainless-steel. A stainless-steel grounding lug is welded to the baseplate and provides a hole for attaching the grounding connector. Mounting holes or slots are located in each corner of the baseplate. Mounting hardware is supplied with the transformer. The transformer can be mounted with the primary terminals in any position-up, down, or horizontal. It can be bolted directly to a crossarm attached by "U" bolts or suspension hooks, or mounted on double crossarms, using channel brackets. Refer to the Accessories Listing on the transformer data sheet for Catalog Numbers.

Nameplate

The nameplate is made of stainless-steel and located on the base of the transformer. Information is per IEEE designation, laser-engraved for easy-to-read form. Custom barcoding available upon request.

Rating Identification

The primary current rating is identified by large orange digits located on two sides of the transformer. This provides permanent identification that is clearly visible from a distance, and is resistant to fading and abrasion.

Maintenance

These transformers require no maintenance other than an occasional cleaning if installed in an area where air contamination is severe.

For more information, visit
governova.com/grid-solutions

Instrument Transformers LLC reserve the right to change specifications of described products at any time without notice and without obligation to notify any person of such changes.

© 2025 GE Vernova and/or its affiliates. All rights reserved. GE and the GE Monogram are trademarks of General Electric Company used under trademark license.



GEA-N50484
English
251022