

# MODEL CTD-5

## Capacitor Trip Device



REGULATORY AGENCY APPROVALS



### Application

Provides a source of energy for circuit breaker and switch trip coil operation during a loss of AC control voltage.

### Normal Input

120 or 240 Volts ac.

### Frequency

25 to 400 Hz.

### Specifications

#### Normal Input Voltage:

CTD-5-120: 120 VAC  
CTD-5-240: 240 VAC

#### Max. Input Voltage:

CTD-5-120: 132 VAC,  
CTD-5-240: 264 VAC

#### Available Energy:

CTD-5-120: 64 joules  
CTD-5-240: 57 joules

#### Normal Output Voltage:

CTD-5-120: 169 Volts DC,  
CTD-5-240: 338 Volts DC

#### Approx charge time to 90% at 25°C:

CTD-5-120: 1.4 S,  
CTD-5-240: 570 mS

#### Capacitance:

CTD-5-120: 4500 uF +20% @ 25°C  
CTD-5-240: 990 uF+ 20% @ 25°C

#### Temp. Influence on cap.:

-10% @ -30°C/±5% @ +60°C

#### Operating temperature range:

-30°C to 60°C

#### Storage temp range:

-50°C to 80°C

#### Short Circuit Protection:

Continuous

#### Mounting:

Vertical or horizontal

#### Input Surge Protection:

MOV protected to 65 joules pulse surge

#### Output contact rating:

Resistive: 5 A, 250 VAC 5 A, 30 VDC

#### Inductive:

2 A, 250 VAC 3 A, 30 VDC  
1/6 HP 120 VAC,  
1/3 HP, 240 VAC

- These devices are protected against inadvertent output short circuit, inductive kickback from the trip coil, and input line voltage surges.

Nominal 120 Volts ac, or 240 Volts ac is applied between the "INPUT" and "COMMON" terminals. This voltage is half wave rectified and applied across the trip capacitor, giving an output trip voltage. The charge stored in these capacitors is available between the '+' and "COMMON" terminals for breaker trip coil operation. The half wave rectification circuitry provides the advantage of maintaining a common neutral connection from input while still maintaining the charge in the the trip capacitor after control power is lost.

The capacitor is continuously charged when control power is available, providing energy for normal trip coil operation. Energy for the trip coil operation is immediately available with the loss of control power. When the control power returns, the capacitor automatically charges to supply energy for the next trip coil.

An alarm relay is incorporated to continuously monitor the input and output condition of the device. The relay is normally energy when both input and output voltage are present. If either the input voltage is lost or the output voltage falls below 85% of the normal output level the output alarm contacts transfer to their de-energized status state. LED indicates normal operation. The LED goes out when the alarm contacts transfer to their de-energized state.



## Model CTD-5

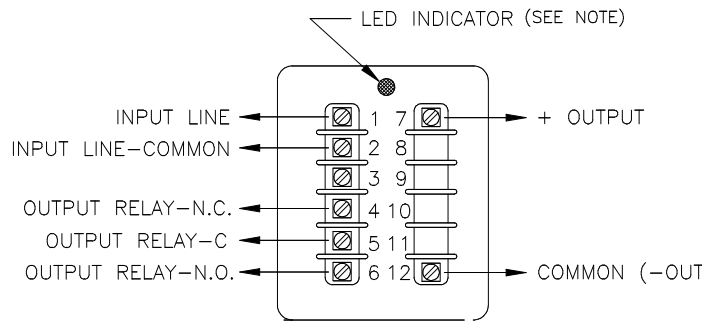
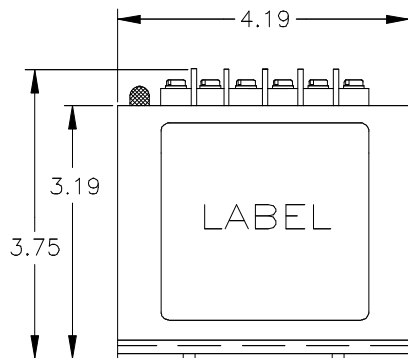
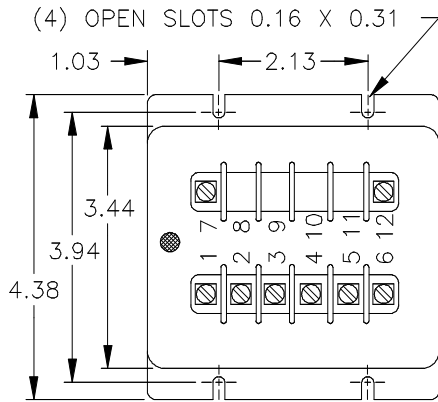

### Notes:

1. The output contacts are shown in the de-energized condition. Contacts will pick up when input and output voltage is present. If the output DC voltage drops below 85% of the expected operating level or the input voltage is lost, then the contacts will change state and the LED indicator will no longer illuminated.
2. TDR is temperature dependent resistor.

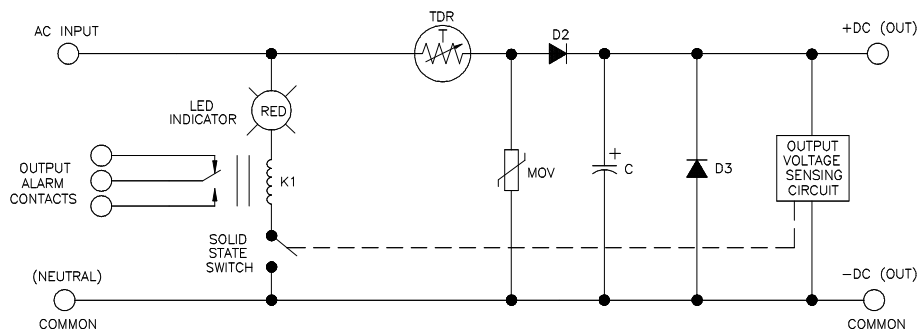

For more information, visit  
[governova.com/grid-solutions](http://governova.com/grid-solutions)

Instrument Transformers LLC reserve the right to change specifications of described products at any time without notice and without obligation to notify any person of such changes.

© 2025 GE Vernova and/or its affiliates. All rights reserved. GE and the GE Monogram are trademarks of General Electric Company used under trademark license.