

GE VERNOVA  
Grid Solutions

# MU320E

## Integrated Merging Unit – Extended



## Technical Manual

Platform Hardware Version: E

Platform Software Version: 04.2

Publication Reference: MU320E\_TM\_EN\_1.8



GE VERNOVA

# Contents

<b>Chapter 1: Introduction</b>		<b>6</b>
<b>1</b>	<b>Foreword</b>	<b>6</b>
1.1	Target Audience	6
1.2	Nomenclature	6
1.3	Abbreviations	7
<b>2</b>	<b>Product Scope</b>	<b>8</b>
<b>3</b>	<b>Unpacking</b>	<b>8</b>
<b>4</b>	<b>External Indication</b>	<b>9</b>
4.1	MU320E Nameplate	9
<b>5</b>	<b>Features and Benefits</b>	<b>9</b>
5.1	Key Features	9
5.2	Benefits of Using MU320E	10
<b>6</b>	<b>Compliance</b>	<b>11</b>
6.1	Standard Compliance	11
<b>7</b>	<b>Functional Overview</b>	<b>11</b>
<b>8</b>	<b>Ordering Options</b>	<b>13</b>
<b>Chapter 2: Safety Information</b>		<b>14</b>
<b>1</b>	<b>Health and Safety</b>	<b>14</b>
<b>2</b>	<b>Symbols</b>	<b>15</b>
<b>3</b>	<b>Installation, Commissioning and Servicing</b>	<b>15</b>
3.1	Lifting Hazards	15
3.2	Electrical Hazards	16
3.3	Fusing Requirements	17
3.4	Equipment Connections	18
3.5	Pre-energization Checklist	19
3.6	Peripheral Circuitry	19
3.7	Upgrading/Servicing	20
<b>4</b>	<b>Decommissioning and Disposal</b>	<b>21</b>
<b>5</b>	<b>Standards Compliance</b>	<b>21</b>
5.1	EMC Compliance:	21
5.2	Product Safety: 2006/95/EC	21
5.3	R&TTE Compliance	22
<b>Chapter 3: Hardware Design</b>		<b>23</b>
<b>1</b>	<b>Hardware Architecture</b>	<b>23</b>
1.1	General Architecture	23
1.2	Internal Hardware Design	24
<b>2</b>	<b>Mechanical Implementation</b>	<b>25</b>
2.1	MU320E Front View	25
2.2	MU320E Rear View	25

<b>3</b>	<b>General Health and Indicator status</b>	<b>27</b>
<b>Chapter 4: Configuration</b>		<b>29</b>
<b>1</b>	<b>MU320 Extended Configurator Screens</b>	<b>29</b>
1.1	Welcome Screen	29
1.2	Main Configuration Screen	31
1.3	Communication Screen	34
<b>2</b>	<b>Password and Access Levels</b>	<b>35</b>
<b>3</b>	<b>Creating a New Configuration File</b>	<b>35</b>
<b>4</b>	<b>Receiving an Equipment Configuration File</b>	<b>37</b>
<b>5</b>	<b>Opening a Pre-existing Configuration File</b>	<b>37</b>
<b>6</b>	<b>Saving a Configuration File</b>	<b>37</b>
<b>7</b>	<b>Sending a Configuration File for the Equipment</b>	<b>37</b>
<b>8</b>	<b>LOG</b>	<b>37</b>
<b>9</b>	<b>Configuration Tabs</b>	<b>38</b>
9.1	IED Settings	38
9.2	Power System Settings	46
9.3	Sampled Values Settings	47
9.4	Binary Settings	50
9.5	GOOSE and Report Settings	54
9.6	Logic Settings	61
9.7	Upgrade Settings	67
9.8	Access Control CLI	68
<b>Chapter 5: Operation</b>		<b>69</b>
<b>1</b>	<b>Local Interface</b>	<b>69</b>
<b>2</b>	<b>Remote Interface</b>	<b>70</b>
2.1	HMI Screen	70
2.2	Log SCREEN	78
2.3	Administrative tools SCREEN	80
<b>3</b>	<b>Measurement Behavior</b>	<b>80</b>
<b>4</b>	<b>Holdover, Free Running and Resynchronization</b>	<b>81</b>
<b>5</b>	<b>Mode/Behavior</b>	<b>82</b>
<b>6</b>	<b>MMS Interactions</b>	<b>82</b>
<b>7</b>	<b>Quality bits</b>	<b>82</b>
7.1	Sampled Values Quality Bits	82
7.2	Goose and MMS Quality Bits	83
<b>8</b>	<b>Signaling Health of the MU320E</b>	<b>83</b>
<b>9</b>	<b>Network Traffic Control</b>	<b>84</b>
9.1	MAC Parity Filtering	84
9.2	Sampled Values Filtering	85

<b>Chapter 6: Communication</b>		<b>86</b>
<b>1</b>	<b>Communication Interfaces</b>	<b>86</b>
1.1	Ethernet Ports Default IP Address	87
<b>2</b>	<b>Communication through Network Using the Optical Ethernet Interface</b>	<b>87</b>
2.1	Communication Ports and Protocols	87
2.2	Communication Setup	87
<b>Chapter 7: Installation</b>		<b>88</b>
<b>1</b>	<b>Handling the Goods</b>	<b>88</b>
1.1	Receipt of the Goods	88
1.2	Unpacking the Goods	88
1.3	Storing the Goods	89
1.4	Dismantling the Goods	89
<b>2</b>	<b>Normal Use of the Equipment</b>	<b>89</b>
<b>3</b>	<b>Mounting the Device</b>	<b>89</b>
3.1	Mechanical Installation	89
<b>4</b>	<b>Cables and Connectors</b>	<b>90</b>
4.1	Power Supply Connections	90
4.2	Powering Up	92
4.3	Earth Connection	92
4.4	IN SERVICE Contact	93
4.5	Optical IRIG-B Input	94
4.6	Binary Inputs and Outputs	94
4.7	Analog Inputs	96
<b>5</b>	<b>Case Dimensions</b>	<b>98</b>
5.1	MU320E Dimensions and Weight	98
5.2	Panel Cutout	99
5.3	Accessories	99
<b>6</b>	<b>Merging Unit Configurator Software Installation</b>	<b>100</b>
6.1	Minimal requirements	100
6.2	Installing	101
6.3	Uninstalling	102
<b>Chapter 8: Maintenance</b>		<b>103</b>
<b>1</b>	<b>Maintenance</b>	<b>103</b>
1.1	Synchronization Failure (SYNC Indicator does not light up)	103
1.2	Cleaning Instructions	103
1.3	Instructions for Equipment Repair Service	103
<b>2</b>	<b>Procedure to reset password and IP address</b>	<b>104</b>
<b>3</b>	<b>Firmware Update</b>	<b>104</b>
<b>Chapter 9: Technical Specifications</b>		<b>105</b>

---

<b>1</b>	<b>Specifications</b>	<b>105</b>
1.1	Power Supply	105
1.2	IN SERVICE Contact	105
1.3	Optical IRIG-B Input	105
1.4	Internal Oscillator	106
1.5	Binary Inputs	106
1.6	Binary Outputs	106
1.7	Analog Acquisition	107
1.8	Current Inputs	107
1.9	Voltage Inputs	108
1.10	Optical Ethernet Ports	108
1.11	Serial Ports	108
1.12	Environment Conditions	109
1.13	Dimensions and Weight	109
1.14	Type Test MU320E	110
<b>Chapter 10: Wiring Diagrams</b>		<b>113</b>
<b>1</b>	<b>Current Connections</b>	<b>113</b>
<b>2</b>	<b>Voltage Connections</b>	<b>115</b>
<b>3</b>	<b>Connection Example</b>	<b>116</b>
<b>Appendix A - PRP</b>		<b>117</b>
<b>1</b>	<b>Parallel Redundancy Protocol (PRP)</b>	<b>117</b>
<b>Appendix B - Log Codes</b>		<b>119</b>
<b>1</b>	<b>List of log codes</b>	<b>119</b>
<b>Appendix C - RADIUS Configuration</b>		<b>121</b>
<b>1</b>	<b>RADIUS Configuration</b>	<b>121</b>
<b>Appendix D - Assistance</b>		<b>122</b>
<b>1</b>	<b>For further assistance</b>	<b>122</b>

---

# MU320E

## Integrated Merging Unit

### Chapter 1: Introduction

This chapter provides some general information about the technical manual and an introduction to the device(s) described in this technical manual.

---

#### 1 Foreword

This technical manual provides a functional and technical description of GE Vernova Reason MU320E, as well as a comprehensive set of instructions for using the device. The level at which this manual is written assumes that you are already familiar with protection engineering and have experience in this discipline. The description of principles and theory is limited to that which is necessary to understand the product. We have attempted to make this manual as accurate, comprehensive, and user-friendly as possible. However, we cannot guarantee that it is free from errors. Nor can we state that it cannot be improved. We would therefore be very pleased to hear from you if you discover any errors or have any suggestions for improvement. Our policy is to provide the information necessary to help you safely specify, engineer, install, commission, maintain, and eventually dispose of this product. We consider that this manual provides the necessary information, but if you consider that more details are needed, please contact us.

All feedback should be sent to our contact center via the following URL:

<https://www.governova.com/grid-solutions/contact.htm>

---

#### 1.1 Target Audience

This manual is aimed towards all professionals charged with installing, commissioning, maintaining, troubleshooting, or operating any of the products within the specified product range. This includes installation and commissioning personnel as well as engineers who will be responsible for operating the product.

The level at which this manual is written assumes that installation and commissioning engineers have knowledge of handling electronic equipment. In addition, system and protection engineers have a thorough knowledge of protection systems and associated equipment.

---

#### 1.2 Nomenclature

Due to the technical nature of this manual, many special terms, abbreviations and acronyms are used throughout the manual. Some of these terms are well-known industry-specific terms while others may be special product-specific terms used by GE Vernova Grid Solutions.

---

## 1.3 Abbreviations

AC (a.c.) – Alternating Current  
A/D – Analog/Digital (converter)  
CD-ROM – Compact Disc - Read Only Memory  
CID – Configured IED Description  
CR2032 – Lithium battery model  
CT – Current Transformer  
DA – Data Attribute  
DO – Data Object  
DC (d.c.) – Direct Current  
FPGA – Field Programmable Gate Array  
GOOSE – Generic Object-Oriented Substation Events  
GCB – GOOSE Control Block  
IEC – International Electrotechnical Commission  
IED – Intelligent Electronic Devices  
IEEE – Institute of Electric and Electronic Engineers  
I/O – Abbreviation of Input/Output  
IMB - Imbalance  
IP – Internet Protocol  
IRIG-B – Time synchronization protocol Inter Range Instrumentation Group (Rate Designation B)  
LAN – Local Area Network  
LED – Light Emitting Diode  
LD – Logical Device  
LN – Logical Node  
MAC – Media Access Control  
MMS – Manufacturing Message Specification (ISO 9506)  
MU – Merging Unit  
NC – Normally Closed  
NO – Normally Opened  
RAM – Random Access Memory  
RX – Receiver data connector  
SCD – Substation configuration description  
SCL – System Configuration description Language  
SSH – Secure Shell  
SV – Sampled Values  
Sync – Abbreviation of synchronization  
TCP – Transmission Control Protocol  
TX – Transmitting data connector  
PIU – Process Interface Unit  
VLAN – Virtual Local Area Network  
VT – Voltage Transformer

## 2 Product Scope

MU320E is the Process Interface Unit (PIU) with analog and binary interfaces for full switchyard modelling, control and digitalization over IEC 61850 standards and protocols such as Sampled Value (SV) and GOOSE.

The MU320E permits the full value of a completely digital substation, as the I/O interface to every bay IED, especially protective relays and bay control units. Limiting the field wiring to only the MU320E reduces project complexity by reducing cabling and physical connections. Bay IEDs can use data from redundant MU320E units, increasing system availability. Bay IEDs can be quickly replaced as no field wiring is involved. The MU320E has the additional benefit of improving CT performance and cost through a lower connected burden and a reduction in the number of CT cores required for an application.



MU320E

## 3 Unpacking

Unpack the equipment carefully and make sure that all accessories and cables are put away so they will not be lost.

Check the contents against the packing list. If any of the contents listed is missing, please contact GE Vernova immediately (see contact information at the beginning of this manual).

Examine the equipment for any shipping damage. If the unit is damaged or fails to operate, notify the shipping company immediately. Only the consignee (the person or company receiving the unit) can file a claim against the carrier for occasional shipping damages.

We recommend that the user retain the original packing materials for use in case of need to transport or ship the equipment at some future time.

## 4 External Indication

### 4.1 MU320E Nameplate

Information about the company, power supply, the serial number and part number is shown on a small nameplate affixed to the rear of the equipment, as shown in figure below.



*Location of Serial Number, Part Number and specifications*

## 5 Features and Benefits

### 5.1 Key Features

- IEC 61850-9-2LE (Sampled Values) compliant.
- EC 61850-8-1 ed2.0 (GOOSE) support
- Report control blocks
- Protection and Measurement Sampled Values profile support.
- Monitoring and control using MMS protocol.
- Use of virtual LAN and priority tag (802.1Q).
- Transfer time of GOOSE signals within Type 1A, performance class P1 (less than 3ms)
- Support for network redundancy PRP (IEC 62439-3).

- In the event of communication loss, all main information is signaled via LEDs (Power, In Service, Alarm, Sync, LAN A and LAN B).
- Front-end IED configuration tools for standardized SCL file.
- Synchronized via IRIG-B or PTP version 2 IEEE 1588 protocol.
- Excellent performance and stability.
- Up to 16 analog inputs. 8 voltages and 8 currents.
- High accuracy analog board with 4VT + 4CT
- Up to 96 conventional digital inputs and up to 32 digital GOOSE inputs.
- Up to 48 binary outputs.
- 2 simultaneous Sampled Values streams.
- Binary inputs and outputs via GOOSE messages.
- Installed in the substation courtyard within appropriate panel.
- Operating temperature -40 °C (-40 °F) to +55 °C (+131°F).
- Fan-less and no rotating part design
- Fail-Safe relay (Watchdog)
- Self-monitoring (internal voltages and temperature)
- Synchronization Holdover
- Circuit neutral calculation
- IEC61850 Quality Bits
- Combined GOOSE inputs to operate a Binary Output
- IEC61850 modelling for interface with Circuit Breakers and Switches
- Connection between digital signals and data model
- Interface for logic configuration of Binary Inputs and Binary Outputs
- Test mode
- Local time

---

## 5.2 Benefits of Using MU320E

- Compact form factor supports field installation options into circuit breakers cabinets, marshalling kiosks and metal-clad switchgear.
- 6 slots for I/O cards allows multiple applications. Apply as Merging Unit, Remote I/O device or PIU. Right size and point count for all type of application.
- Card slots for 2 CT/VT analog boards supports application on breaker-and-a-half lines, dual distribution feeders, and combination protection and metering installations.
- Optional metering accuracy CT/VT analog board for revenue metering and power quality applications.
- 2 SV streams possible (one per CT/VT analog board). Each stream can be protection (80 s/c) or power quality (256 s/c) SV streams.

- Full integration into the digital substation through 2 Ethernet ports, support for Parallel Redundancy Protocol (PRP) high availability networks, and IEEE 1588 Precision Time Protocol.
- Full IEC 61850 Edition 2, including support for Test mode and Simulation. Multiple logical devices to integrate multiple circuit breakers and disconnectors in one MU320E.

---

## 6 Compliance

The MU320E is a **RoHS 3 compliant** product has undergone a range of extensive testing and certification processes to ensure and prove compatibility with all target markets. A detailed description of these criteria can be found in the Technical Specifications Chapter.

---

### 6.1 Standard Compliance

Compliance with the European Commission Directive and UK Conformity Assessed on EMC and LVD is demonstrated by self-certification against international standards.



---

## 7 Functional Overview

The Merging Unit MU320E is the interface from the physical analog world to the digital, using communication networks. The analog signal is converted to digital and transmitted via Sampled Values (SV) network communication protocol.

The equipment can be used in both new substations or to modernize existing facilities. Being fully IEC 61850 compliant enables interoperability with any process bus device.

The process bus solution, besides the technological advancements, allows for cost savings inherent to the design, maintenance and installations, mainly due to the simplified Ethernet cabling networks.

An application example using the MU320E is presented below.

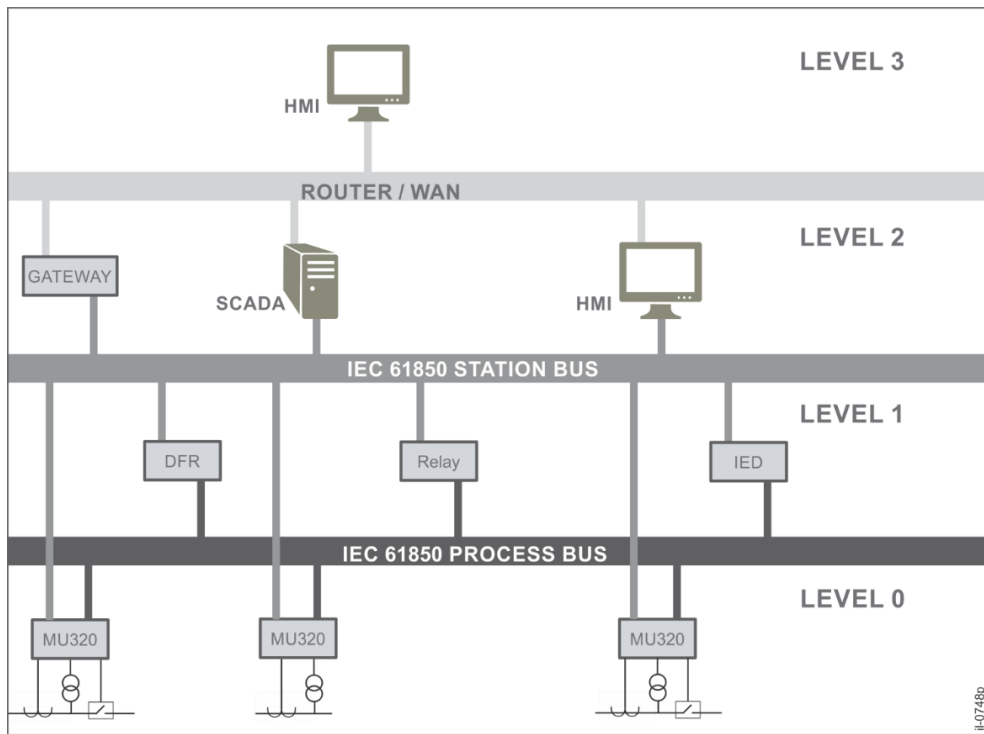

*Application example using the MU320E*

## 8 Ordering Options

Information required with order:	Variants																								
	1-5	6	7	8-9	10-11	12-13	14-15	16-17	18-19	20	21	22-23	24	25											
<b>Model type:</b> MU320 Merging Unit	MU320																								
<b>Slot A - Power Supply</b> 48 Vdc 110-250 Vdc / 110-240 Vac		1 3																							
<b>Slot B - Hardware Options</b> Processing unit + two multimode LC-type connector 100BASE-FX Ethernet interfaces			O																						
<b>Slot C - Binary I/O</b> 16 x 24/48/125/250 V binary inputs 6 x 24/48/125/250 V binary inputs and 8 x Form-A binary outputs 6 x 24/48/125/250 V binary inputs and 4 x Form C + 2 x Form A binary outputs 6 x 24/48/125/250 V binary inputs and 8 x High Speed Form A binary outputs Not installed					B3 B4 B5 B6 XX																				
<b>Slot D - Binary I/O</b> 16 x 24/48/125/250 V binary inputs 6 x 24/48/125/250 V binary inputs and 8 x Form-A binary outputs 6 x 24/48/125/250 V binary inputs and 4 x Form C + 2 x Form A binary outputs 6 x 24/48/125/250 V binary inputs and 8 x High Speed Form A binary outputs Not installed					B3 B4 B5 B6 XX																				
<b>Slot E - Binary I/O</b> 16 x 24/48/125/250 V binary inputs 6 x 24/48/125/250 V binary inputs and 8 x Form A binary outputs 6 x 24/48/125/250 V binary inputs and 4 x Form C + 2 x Form A binary outputs 6 x 24/48/125/250 V binary inputs and 8 x High Speed Form A binary outputs Not installed								B3 B4 B5 B6 XX																	
<b>Slot F - Binary I/O</b> 16 x 24/48/125/250 V binary inputs 6 x 24/48/125/250 V binary inputs and 8 x Form A binary outputs 6 x 24/48/125/250 V binary inputs and 4 x Form C + 2 x Form A binary outputs 6 x 24/48/125/250 V binary inputs and 8 x High Speed Form A binary outputs Not installed								B3 B4 B5 B6 XX																	
<b>Slot G - Flexible I/O Options</b> 16 x 24/48/125/250 V binary inputs 6 x 24/48/125/250 V binary inputs and 8 x Form A binary outputs 6 x 24/48/125/250 V binary inputs and 4 x Form C + 2 x Form A binary outputs 6 x 24/48/125/250 V binary inputs and 8 x High Speed Form A binary outputs 4 x VT 115 V and 4 CT 1/5 A RMS measurement analog inputs 4 x VT 115 V and 4 x CT 1 A RMS protection analog inputs 4 x VT 115V and 4 x CT 5 A RMS protection analog inputs Not installed								B3 B4 B5 B6 ME P1 P5 XX																	
<b>Slot H - Flexible I/O Options</b> 16 x 24/48/125/250 V binary inputs 6 x 24/48/125/250 V binary inputs and 8 x Form A binary outputs 6 x 24/48/125/250 V binary inputs and 4 x Form C + 2 x Form A binary outputs 6 x 24/48/125/250 V binary inputs and 8 x High Speed Form A binary outputs 4 x VT 115 V and 4 CT 1/5 A RMS measurement analog inputs 4 x VT 115 V and 4 x CT 1 A RMS protection analog inputs 4 x VT 115V and 4 x CT 5 A RMS protection analog inputs Not installed								B3 B4 B5 B6 ME P1 P5 XX																	
<b>Functions and Application</b> Standard Integrated Merging Unit PRP redundant Integrated Merging Unit																					A B				
<b>Reserved</b> Not used																							X		
<b>Firmware Version</b> Latest available firmware - 04																								04	
<b>Coating</b> Standard																								S	
<b>Hardware Design Suffix</b> Hardware Version E																									E

---

# MU320E

## Integrated Merging Unit

### Chapter 2: Safety Information

This chapter provides information about the safe handling of the equipment. The equipment must be properly installed and handled in order to maintain it in a safe condition and to keep personnel safe at all times. You must be familiar with information contained in this chapter before unpacking, installing, commissioning, or servicing the equipment.

---

#### 1 Health and Safety

Personnel associated with the equipment must be familiar with the contents of this Safety Information.

When electrical equipment is in operation, dangerous voltages are present in certain parts of the equipment. Improper use of the equipment and failure to observe warning notices will endanger personnel.

Only qualified personnel may work on or operate the equipment. Qualified personnel are individuals who are:

- familiar with the installation, commissioning, and operation of the equipment and the system to which it is being connected.
- familiar with accepted safety engineering practices and are authorized to energize and de-energize equipment in the correct manner.
- trained in the care and use of safety apparatus in accordance with safety engineering practices
- trained in emergency procedures (first aid).

The documentation provides instructions for installing, commissioning and operating the equipment. It cannot, however, cover all conceivable circumstances. In the event of questions or problems, do not take any action without proper authorization. Please contact your local sales office and request the necessary information.

*Each product is subjected to routine production testing for Dielectric Strength and Protective Bonding Continuity*

## 2 Symbols

Throughout this manual you will come across the following symbols. You will also see these symbols on parts of the equipment.



Caution: Refer to equipment documentation. Failure to do so could result in damage to the equipment



**Risk of electric shock**



Ground terminal. Note: This symbol may also be used for a protective conductor (ground) terminal if that terminal is part of a terminal block or sub-assembly.



Protective conductor (ground) terminal



Both direct and alternating current



Instructions on disposal requirements

*The term 'Ground' used in this manual is the direct equivalent of the European term 'Earth'.*

## 3 Installation, Commissioning and Servicing

### 3.1 Lifting Hazards

Many injuries are caused by:

- Lifting heavy objects
- Lifting things incorrectly
- Pushing or pulling heavy objects
- Using the same muscles repetitively

Plan carefully, identify any possible hazards and determine how best to move the product. Look at other ways of moving the load to avoid manual handling. Use the correct lifting techniques and Personal Protective Equipment (PPE) to reduce the risk of injury.

### 3.2 Electrical Hazards



All personnel involved in installing, commissioning, or servicing this equipment must be familiar with the correct working procedures.



Consult the equipment documentation before installing, commissioning, or servicing the equipment.



Always use the equipment as specified. Failure to do so will jeopardize the protection provided by the equipment.



**Removal of equipment panels or covers may expose hazardous live parts. Do not touch until the electrical power is removed. Take care when there is unlocked access to the rear of the equipment.**



**Isolate the equipment before working on the terminal strips.**



**Use a suitable protective barrier for areas with restricted space, where there is a risk of electric shock due to exposed terminals.**



Disconnect power before disassembling. Disassembly of the equipment may expose sensitive electronic circuitry. Take suitable precautions against electrostatic voltage discharge (ESD) to avoid damage to the equipment.



NEVER look into optical fibers or optical output connections. Always use optical power meters to determine operation or signal level.



Testing may leave capacitors charged to dangerous voltage levels. Discharge capacitors by reducing test voltages to zero before disconnecting test leads.



If the equipment is used in a manner not specified by the manufacturer, the protection provided by the equipment may be impaired.



Operate the equipment within the specified electrical and environmental limits.



Before cleaning the equipment, ensure that no connections are energized. Use a lint free cloth dampened with clean water.



Integration of the equipment into systems shall not interfere with its normal functioning.



The functioning of the device has been certified under the circumstances described by the standards mentioned in Chapter 9: Technical Specifications (Type Tests). Usage of the equipment in different conditions from the specified in this manual might affect negatively its normal integrity.



The equipment shall have all their rear connectors attached even if they are not being used, in order to keep their levels of ingress protection as high as possible



Never manipulate liquid containers near the equipment even when it is powered off.



Avoid modification to the wiring of panel when the system is running.



VT circuits must never be left short circuited.

### 3.3 Fusing Requirements



A high rupture capacity (HRC) fuse type with a maximum current rating of 10 Amps and a minimum dc rating of 250 Vdc may be used for the auxiliary supply (for example Red Spot type NIT or TIA). Alternatively a miniature circuit breaker (MCB) of type C, 10A rating, compliant with IEC 60947-2 may be used.



Digital input circuits should be protected by a high rupture capacity NIT or TIA fuse with maximum rating of 10 A, or equivalent MCB as above. For safety reasons, current transformer circuits must never be fused. Other circuits should be appropriately fused to protect the wire used.



Reason devices contain an internal fuse for the power supply which is only accessed by opening the product. This does not remove the requirement for external fusing or use of an MCB as previously mentioned. The ratings of the internal fuses are: MU320E unit: 2 Amp, type T, 250V rating



CTs must NOT be fused since open circuiting them may produce lethal hazardous voltages.

### 3.4 Equipment Connections



**Terminals exposed during installation, commissioning and maintenance may present a hazardous voltage unless the equipment is electrically isolated.**



Tighten M3 clamping screws of heavy duty terminal block connectors to a nominal torque of 1.0 Nm.  
Tighten captive screws of header-type (Euro) terminal blocks to 0.5 Nm minimum and 0.6 Nm maximum.



Always use insulated crimp terminations for voltage and current connections.



Always use the correct crimp terminal and tool according to the wire size.



In order to maintain the equipment's requirements for protection against electric shock, other devices connected to the MU320E shall have protective class equal or superior to Class I.



Watchdog (self-monitoring) contacts are provided to indicate the health of the device on some products. We strongly recommend that you hard wire these contacts into the substation's automation system, for alarm purposes.



Earth the equipment with the supplied PCT (Protective Conductor Terminal).



Do not remove the PCT.



The PCT is sometimes used to terminate cable screens. Always check the PCT's integrity after adding or removing such earth connections.



The user is responsible for ensuring the integrity of any protective conductor connections before carrying out any other actions.



The PCT connection must have low-inductance and be as short as possible. For best EMC performance, ground the unit using a 10 mm (0.4 inch) wide braided grounding strap.



All connections to the equipment must have a defined potential. Connections that are pre-wired, but not used, should be earthed, or connected to a common grouped potential.



Pay extra attention to diagrams before wiring the equipment. Always be sure that the connections are correct before energizing the circuits.

### 3.5 Pre-energization Checklist



Check voltage rating/polarity (rating label/equipment documentation).



Check CT circuit rating (rating label) and integrity of connections.



Check protective fuse or miniature circuit breaker (MCB) rating.



Check integrity of the PCT connection.



Check voltage and current rating of external wiring, ensuring it is appropriate for the application.

### 3.6 Peripheral Circuitry



**Do not open the secondary circuit of a live CT since the high voltage produced may be lethal to personnel and could damage insulation. Short the secondary of the line CT before opening any connections to it.**

*Reason devices DO NOT feature any automatic CT shorting feature. Therefore external shorting of the CTs is mandatory. Check the equipment documentation and wiring diagrams carefully.*



Where external components such as resistors or voltage dependent resistors (VDRs) are used, these may present a risk of electric shock or burns if touched.



Operation of computers and equipment connected to MU320E under environmental conditions such as temperature and humidity that exceed the conditions specified in their respective manuals can cause malfunctioning or even irreversible damage to them or the nearby installation.



There might be situations in which the MU320E is operating within its environmental operational range, but the computers, equipment connected to them or nearby equipment are operating outside their operational range. That situation can cause malfunctioning and/or irreversible damage to those devices. In that occasion the communication to the Reason equipment might be compromised but its recording, operational and safety capacities will not be affected.



**Take extreme care when using external test blocks and test plugs such as the MMLG, MMLB and P990, as hazardous voltages may be exposed. Ensure that CT shorting links are in place before removing test plugs, to avoid potentially lethal voltages.**

---

### 3.7 Upgrading/Serviceing



**Do not insert or withdraw modules, PCBs or expansion boards from the equipment while energized, as this may result in damage to the equipment. Hazardous live voltages would also be exposed, endangering personnel.**



Internal modules and assemblies can be heavy and may have sharp edges. Take care when inserting or removing modules into or out of the IED.

## 4 Decommissioning and Disposal



Before decommissioning, completely isolate the equipment power supplies (both poles of any dc supply). The auxiliary supply input may have capacitors in parallel, which may still be charged. To avoid electric shock, discharge the capacitors using the external terminals before decommissioning.



Avoid incineration or disposal to water courses. Dispose of the equipment in a safe, responsible and environmentally friendly manner, and if applicable, in accordance with country-specific regulations.

## 5 Standards Compliance

Compliance with the European Commission Directive and UK Conformity Assessed on EMC and LVD is demonstrated by self-certification against international standards.



### 5.1 EMC Compliance:

Compliance with IEC 60255-26:2013 was used to establish conformity.

### 5.2 Product Safety: 2006/95/EC

Compliance with IEC 60255-27:2013 was used to establish conformity.

#### Protective Class

IEC 60255-27:2013 Protective Class 1. This equipment requires a protective conductor (earth) to ensure user safety.

#### Installation category

- When using the 100-250 Vdc / 110-240 Vac power supply: IEC 60255-27:2013 Installation category III (Overvoltage Category III). Equipment in this category is qualification tested at 5kV peak, 1.2/50  $\mu$ S, 500 Ohms, 0.5 J, between all supply circuits and earth and also between independent circuits.

- When using the 48 Vdc power supply: IEC 60255-27:2013 Installation category II (Overvoltage Category II).
- Binary Inputs in the board model B4 **version 3**, option with 8 output form-A and 6 binary inputs, has a withstand voltage between these channels of 1.35kV/60s, based on IEC 60255-27:2013.
- Binary Inputs in the board model B4 **version 4 and above**, option with 8 output form-A and 6 binary inputs, has a withstand voltage between these channels of 2.2kV/60s, based on IEC 60255-27:2013.
- Binary Inputs in the board model B6 **version 4 and above**, option with 8 output form-A High Speed High Break and 6 binary inputs, has a withstand voltage between these channels of 2.2kV/60s, based on IEC 60255-27:2013.

To identify what is the board version please refer to Chapter 1, section 2.1.2.

#### **Environment**

IEC 60068-2-1, IEC 60068-2-2, IEC 60068-2-30, IEC 60068-2-14, IEC 60255-21-1, IEC 60255-21-2. The equipment shall always be installed in a specific cabinet or housing which will enable it to meet the requirements of IEC 60529 with the classification of degree of protection IP54 or above.

Pollution degree 2 when mounted in its normal position of use.

---

## 5.3 R&TTE Compliance

Radio and Telecommunications Terminal Equipment (R&TTE) directive 99/5/EC. Conformity is demonstrated by compliance to both the EMC directive and the Low Voltage directive, to zero volts.

# MU320E

## Integrated Merging Unit

### Chapter 3: Hardware Design

This chapter provides information about the product's hardware design.

---

#### 1 Hardware Architecture

---

##### 1.1 General Architecture

The MU320E is composed of up to 8 boards, from slot A to H. A very flexible number of inputs and outputs can be achieved by the combination of the boards. The slot A is reserved for power supply; Slot B for CPU, Ethernet and serial connection and IRIGB synchronization input; Slots C and F are used for binary input/outputs and slots G to H can be used either for binary I/O or analog inputs. The figure below illustrates the MU320E slots composition. For the complete list of board option, refer to the ordering option in Chapter 1.

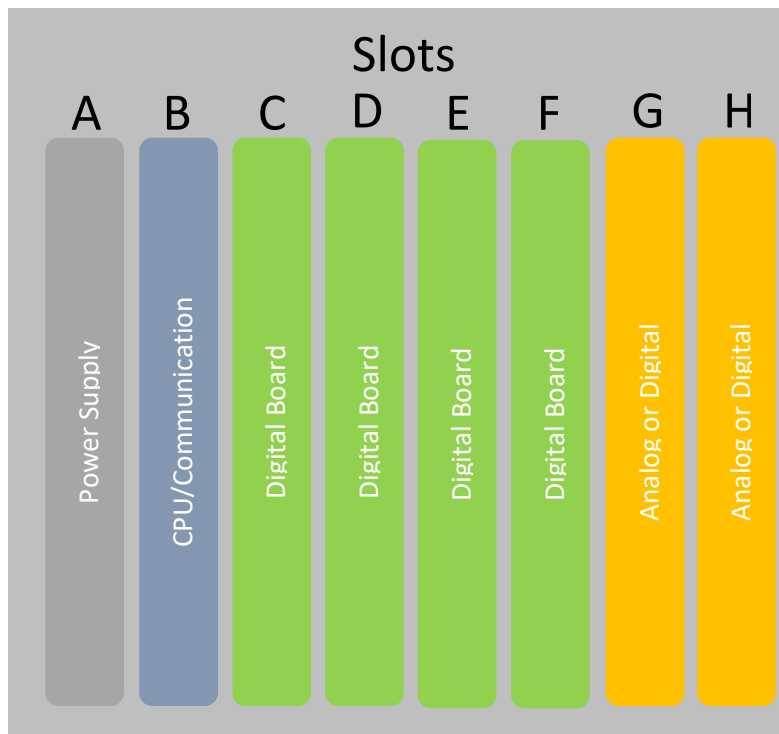

*MU320E slots composition*

## 1.2 Internal Hardware Design

All MU320E control and implementation are performed in a single FPGA (Field Programmable Gate Array) component, not using conventional microprocessors or microcontrollers.

The acquisition and digital filtering control are implemented by hardware, allowing a reduced runtime without affecting performance, provided by the parallelism of the solution.

Below figure shows a block diagram of the overall equipment. Note the simplicity of the system provided by using an FPGA responsible for all processing and control.

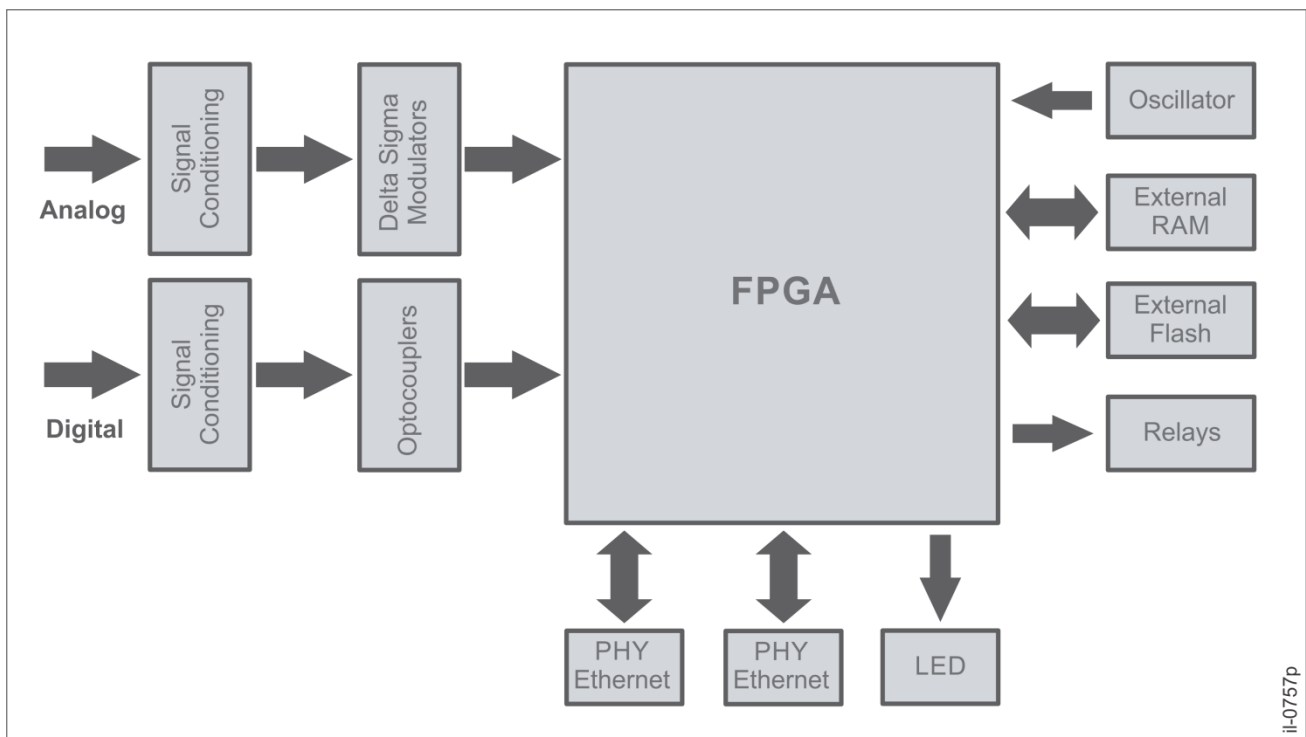

Simple Block Diagram of MU320E

Analog signals (voltages and currents) are initially conditioned, lowering input levels to appropriate values for A/D converters. Each channel has an A/D converter implemented independently with delta-sigma modulators. Analog current channels (IA, IB, IC, and IN) are isolated from each other and from the rest of the system. Analog phase voltages (VA, VB, and VC) are isolated from the rest of the system but not from each other. Analog channel voltage VX is isolated from voltage phase channels and from the rest of the system.

Digital input signals are conditioned and then isolated by optocouplers, going through the FPGA which transmits the information via GOOSE messages to the Ethernet interface.

Digital inputs can be used from the MU320E to acquire information from the system, for example, the state of circuit breakers and switches, and transmit to IEDs through GOOSE messages.

The digital outputs are triggered by GOOSE inputs associated through application software.

The digital outputs are associated with GOOSE messages from other IEDs, for example, to send commands to switching units (circuit breaker, recloser, etc.) and announcements for remote signaling of events and status.

---

## 2 Mechanical Implementation

### 2.1 MU320E Front View

The front panel of MU320E, shown in the figure below, comprises equipment identification, and six status indicators.

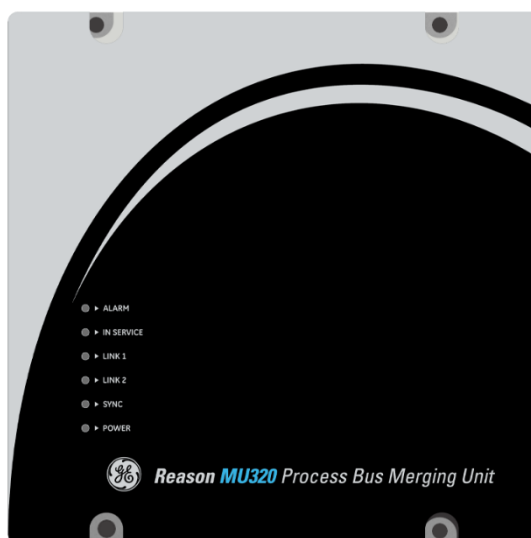

*Front view of MU320E*

The behavior of the front LED behavior is described in the section 3 of this chapter.

---

### 2.2 MU320E Rear View

The rear panel of the MU320E, comprises eight slots, identified from A to H. Power supply is supported in Slot A; Communication port and synchronization input are supported in Slot B; Binary inputs and outputs are supported from slots C-H; Voltage and current analog inputs are supported in slots G and H.

The figure below shows the MU320E rear panel with connectors and indicator LEDs.

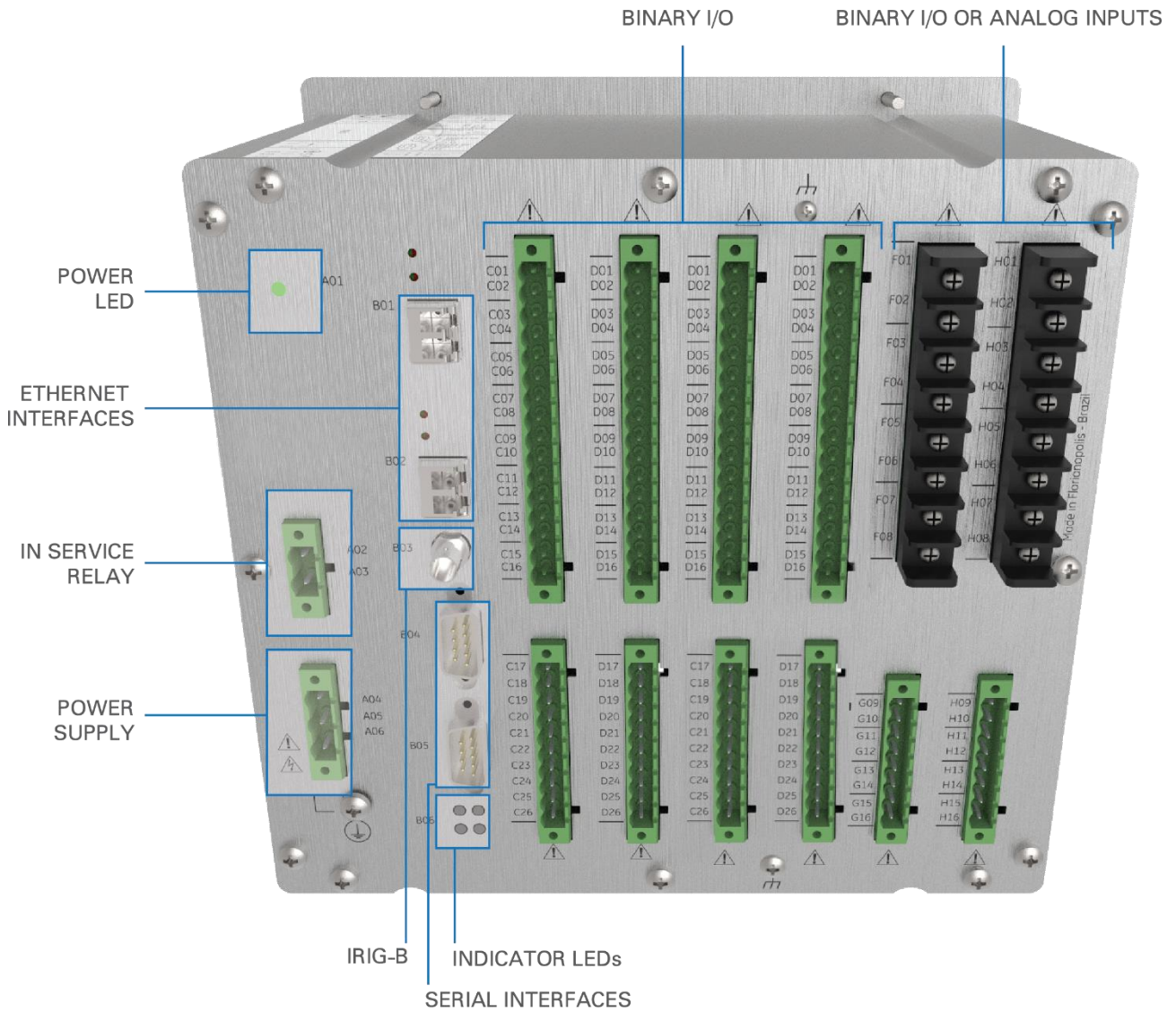

Rear View of the MU320E

The diagram below shows the designation of each LED and its behavior will be explored in the section 3 of this chapter.

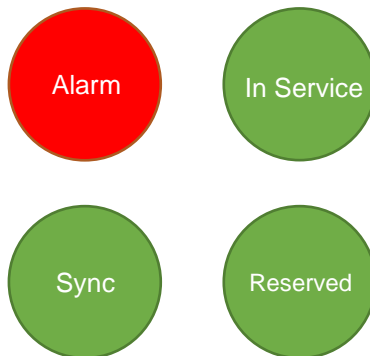

Rear View of the MU320E

The *Reserved* LED is not used in the current version and is always disabled.  
 For information about installing the equipment, refer to Chapter 7: Installation.

### 3 General Health and Indicator status

MU320E has self-monitoring tools to diagnose internal failures or miss operation and these statuses can be noticed using user logs or the physical HMI through LEDs and In Service relay indicators.

Considering the physical HMI, MU320E health logic status is observable considering the table below.

EQUIPMENT HEALTH	ALARM LED	IN SERVICE LED	IN SERVICE RELAY
Ok - not in Test	OFF	ON (Green)	OPEN
Ok - any LD in Test Mode	OFF	ON (Orange)	OPEN
Warning - not in Test	ON (Red)	ON (Green)	OPEN
Warning - any LD in Test Mode	ON (Red)	ON (Orange)	OPEN
Alarm	ON (Red)	OFF	CLOSED

MU320E health state follows the rules in the tables below.

CONDITION	LEADS TO
Invalid module	Alarm
Module not detected	Alarm
Module not compatible	Alarm
Internal voltage	Warning
Internal temperature	Warning
Ethernet link 1 - No Redundancy	Alarm
Only Ethernet link 1 - PRP Redundancy	Warning
Ethernet links 1 and 2 - PRP Redundancy	Alarm
Sample quality - Questionable	Warning
Sample quality - Invalid	Alarm
Analog channel not calibrated	Warning
Synch quality not Ok	Warning

For more details on MU320E health state and signaling, please check session 8 or contact GE Vernova support team.



# MU320E

## Integrated Merging Unit

### Chapter 4: Configuration

The MU320E has an application software called MU320 Extended Configurator that configures the equipment and power system parameters, GOOSE and Sampled Values messages and the logical I/O. The application can read and send configuration files to the equipment and perform administrative and monitoring functions.

This chapter presents an overview of the software and how configuration files are treated.

For information about software installation, refer to Chapter 7: Installation.

---

#### 1 MU320 Extended Configurator Screens

##### 1.1 Welcome Screen

MU320 Extended Configurator Welcome Screen is the starting point where the user will be guided to all software features for MU320E, as show the figure below and the following options:

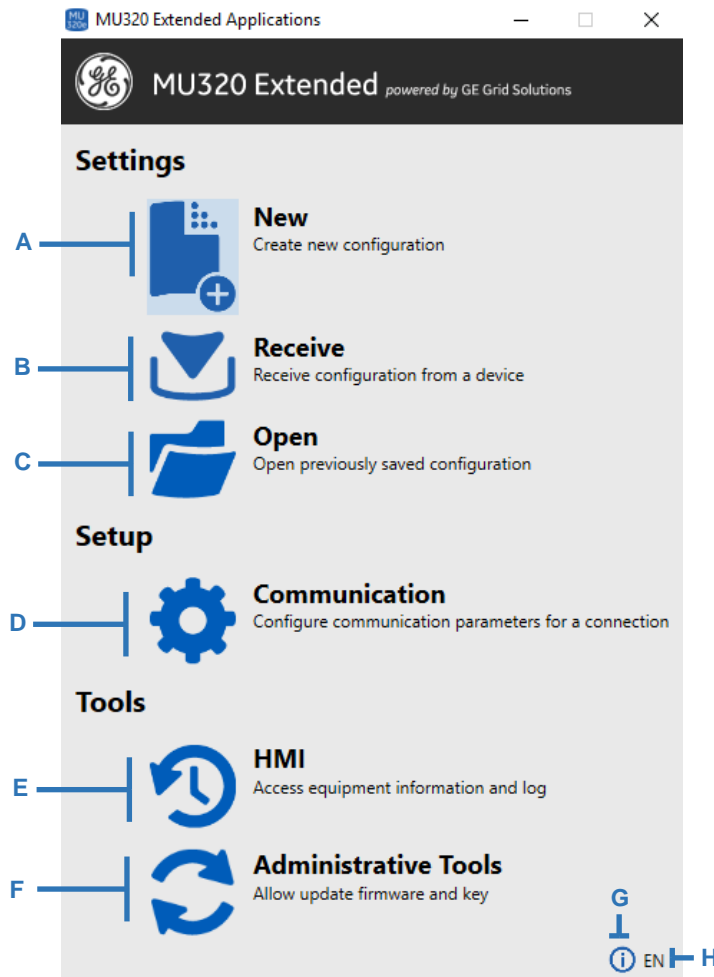

MU320 Extended Configurator initial screen

**A <New>**: creates a new configuration file.

**B <Receive>**: receives the current configuration file from the equipment.

**C <Open>**: opens a file containing a pre-existing configuration.

**D <Communication>**: opens the window that allows to configure communication parameters (ethernet and serial) for connecting to devices and to run the scan of MU320E devices in the network.

**E <HMI>**: this button opens the window containing the following options:

- General device information;
- Analog Acquisition monitoring;
- Binary I/O monitoring;
- GOOSE Subscription monitoring;

**F <Administrative Tools>**: opens the window containing the following options:

- Access control – allows changing the password for each kind of user (CFG, ADM and MON);
- Firmware update;
- License Update;
- Support file – Downloads a support file containing internal logs used for diagnosis;
- Option to remotely reboot the device

**G** <About>: opens the window containing general information about the software, including the software version.

**H** <Language>: allows to configure the software language. Options: EN-US or PT-BR.

## 1.2 Main Configuration Screen

Figure below presents the main screen of the Merging Unit Configurator. This screen appears by opening an existing configuration, reading the device configuration or creating a new configuration, as will be described in the following sections of this chapter.

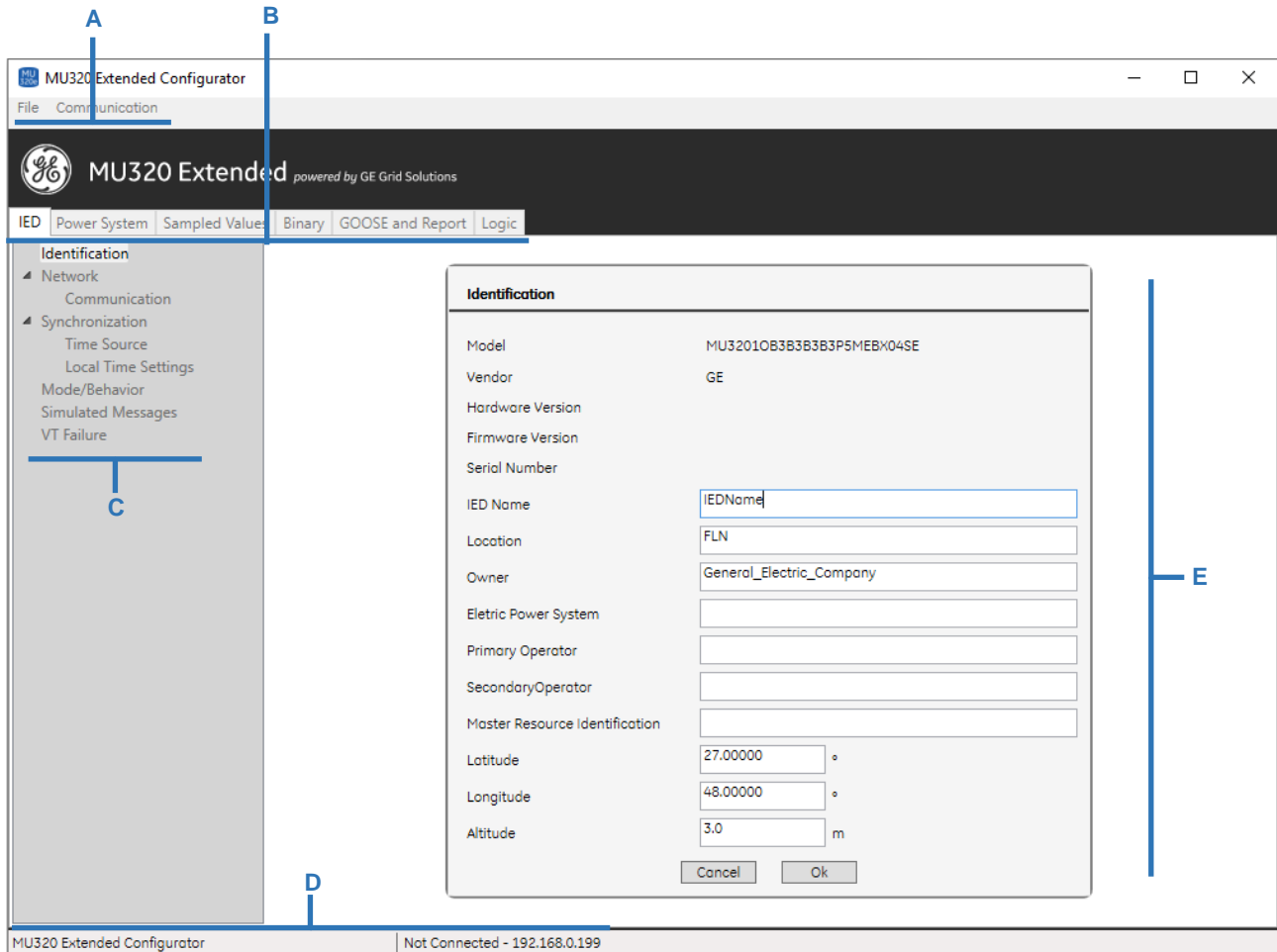

MU320E Extended Configurator Main Screen

The available options this screen are:

- A Menu Bar of Merging Unit Configurator software.
- B Setting tabs of Merging Unit Configurator software.
- C Menu of the configurable parameters for each setting tab of Merging Unit Configurator software.
- D Status Bar of Merging Unit Configurator software.
- E Desktop of Merging Unit Configurator software.

### 1.2.1 MENU BAR

Menu Bar contains menus, that allow the user to:

- Create, open and read configuration files;
- Export the configuration to a PDF file;
- Setup communication parameters;

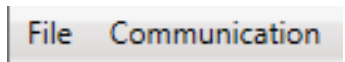

Merging Unit Configurator Menu Bar

The Merging Unit Configurator menu bar functions are detailed below.

MENU	ITEM	DESCRIPTION
File	New CID	Create a new CID file
	Open CID	Open an existing CID file
	Save CID	Save a CID file
	Save CID As	Save a CID file with another name or extension
	Export configuration report as PDF	Creates a PDF file containing all the configured settings
	Exit	Finish the section and close the software
	Update CID to the new firmware version 04A01	In offline mode updates a configuration version 6.0 (used in firmware versoin 04A00) to 6.1 (used in firmware version 04A01)
Communication	Receive Configuration	Receive a configuration file from online equipment
	Send Configuration	Send a configuration file for online equipment

### 1.2.2 SETTING TABS

Settings tabs contain all configurable parameters of the equipment. There are five settings tabs, as shown below.

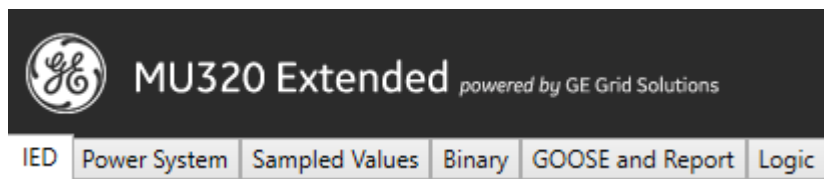

Merging Unit Configurator Settings Tabs

Through the setting tabs it is possible to configure all the equipment adjustments, as detailed on the table below. The possible configurations and how to configure each parameter will be described in the next sections of this chapter.

Place the mouse over the text fields of configurable parameters in order to show the range of values or the possible characters.

The table below describes the menu options:

TAB	ITEM	DESCRIPTION
IED	Identification	Insert an equipment identification.
	Network	Configures parameters for all communication interfaces ( <i>Ethernet 1</i> , <i>Ethernet 2</i> and <i>Serial Port</i> ) and redundancy.
	Time Source	Configures time source for the equipment synchronization.
	Mode/Behavior	Configures MU320E according to the mode and behavior described in IEC 61850-7-4 edition 2 (on, blocked, test, test-blocked and off).
	Simulated Messages	Configures MU320E to accept GOOSE simulated messages.
	VT Fuse Failure	Configures Binary Inputs to represents VT failure fuse inputs.
Power System	MU01	Configures power system parameters to an analog board connected to Slot G.
	MU02	Configures power system parameters to an analog board connected to Slot H.
Sampled Values	MU01	Configures Sampled Values parameters to an analog board connected to Slot G.
	MU02	Configures Sampled Values parameters to an analog board connected to Slot H.
Binary	Binary Outputs	Configures user label to each Binary Output.
	Binary Inputs	Configures for all binary inputs: debounce; pickup; dropout; nominal voltage for each slot; and user label to each Binary Input.
	GOOSE Inputs	Configures user label and default state to each GOOSE input.
GOOSE and Report	Dataset	Configures and create IEC 61850 Datasets
	GOOSE Subscription	Configures subscription to GOOSE control blocks and association to GOOSE inputs.
	GOOSE Publisher	Configures GOOSE Publisher control blocks.
	Report	Configures Report control blocks.
Logic	Circuit Breakers	Configures the association between GOOSE and Binary Inputs to the IEC61850-7-4 datamodel for circuit breakers ( <i>XCBR</i> )
	Circuit Switches	Configures the association between GOOSE and Binary Inputs to the IEC61850-7-4 datamodel for circuit switches ( <i>XSWI</i> )
	Monitoring	Configures the association between GOOSE and Binary Inputs to the IEC61850-7-4 datamodel for Oil Insulation Supervision ( <i>SIML</i> ) and Gas Insulation Supervision ( <i>SIMG</i> )
	Binary Outputs	Configures the association between GOOSE, Binary Inputs or IEC61850-7-4 datamodel ( <i>XCBR</i> , <i>XSWI</i> , <i>SIML</i> and <i>SIMG</i> ) to Binary Outputs

### 1.2.3 STATUS BAR

Status bar presents the software name, the connection status (if it is connected, reading or sending configurations), and the Ethernet IP address.



*MU320 Extended Configurator Status Bar*

## 1.3 Communication Screen

In the figure below is shown the communication screen of the MU320 Extended Configurator with the following options:

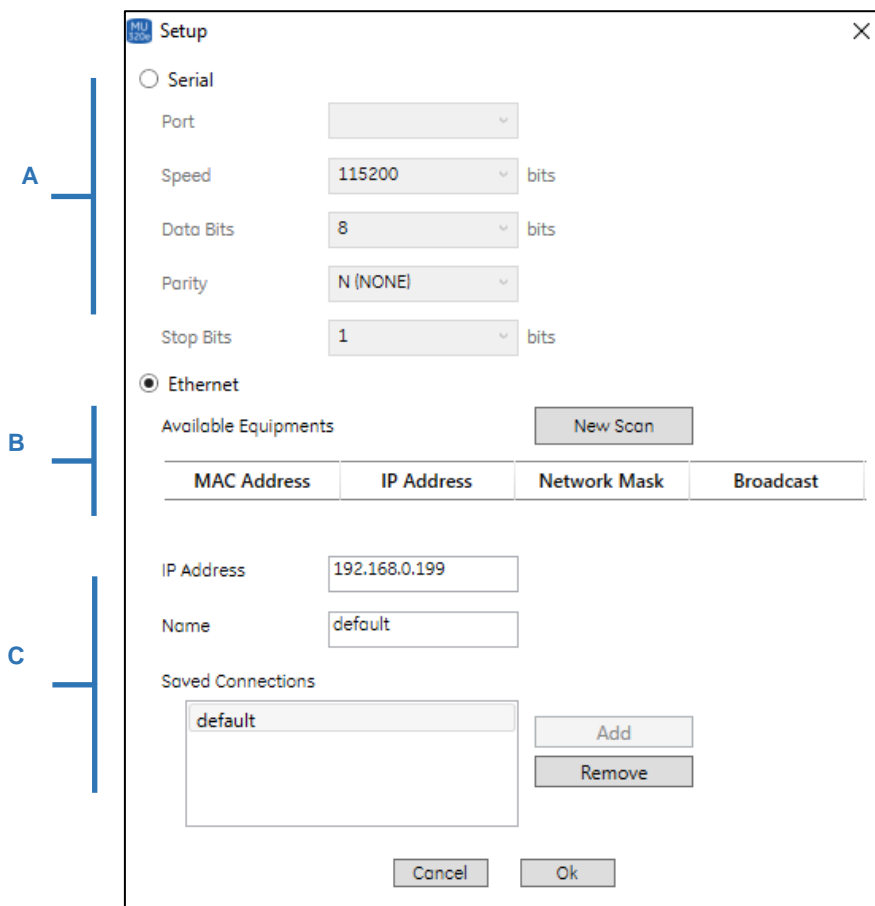

*Communication Screen*

**A** Serial communication section: allows the user to set the software to communicate with the device through serial communication. The parameters in this section are not user configurable and are shown for reference.

**B** IP scan section: allows the user to set the software to communicate with the device through ethernet communication and to perform a scan in the local network, where the

host computer is connected, to find the ethernet configurations of all MU320E connected to that network.

**C** Communication Management section: allows the user to manage IP addresses of MU320E devices making it easier to interact with them.

---

## 2 Password and Access Levels

The MU320E software has three access levels, each one with a corresponding user name. The **MON** user is able access the MU320E HMI menu;

The **CFG** user can access the HMI menu, to create, receive and send configurations and to change its own password.

The **ADM** user can do all that **CFG** user is able to, plus firmware update, device key change and alter all user passwords.

A list with the user names and default password is shown below:

User	Password
CFG	123cfg
ADM	123adm
MON	123mon

MU320E passwords are user-configurable and accepts a combination of upper/lower case (a-z, A-Z), numbers (0-9) and special non-alphabetic characters (e.g. !, @, #, \$, %, ^, &, \*, ?), including blank space ( ), respecting the limits of minimum 6 and maximum 20 characters. The password can be changed using the *administrative tools*.

The MU320E has Remote Authentication Dial-In User Service (RADIUS) networking protocol that provides centralized authentication, authorization, and accounting (AAA). More details in Appendix C - RADIUS Configuration.

---

## 3 Creating a New Configuration File

To create a new configuration, click on the <New> button on the initial screen of the Merging Unit Configurator.

It opens a window, like the one in the figure below, to configure the order code of the equipment, according to hardware configuration.

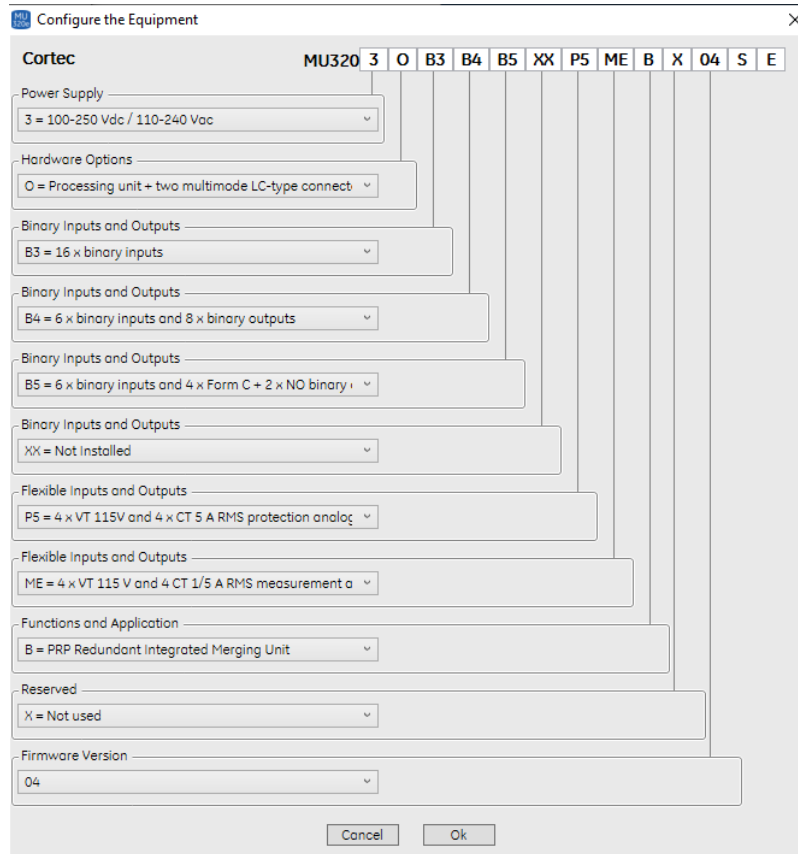

CORTEC selector Screen

**Order Code:** the order code must be created based on the equipment hardware configuration. On each field insert the configuration of the respective slot. The order code of the equipment is displayed on the label affixed on the equipment.

**<Cancel>**: this button cancels the order code edition and goes back to the initial screen of the Merging Unit Configurator.

**<Ok>**: this button confirms the order code edition and opens the main screen of the Merging Unit Configurator.

It is also possible to create a new configuration file through the Main Screen of the Merging Unit Configurator, by selecting the option New CID on the File menu.

On pressing **<Ok>** button the user will be able to select which configuration version will be created. Each configuration version is associated to a firmware version.

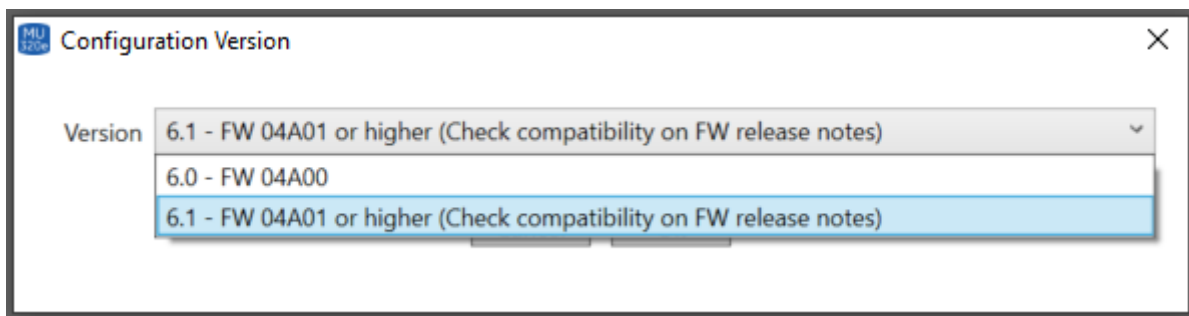

Configuration version selection

---

## 4 Receiving an Equipment Configuration File

After configuring the communication path (IP address or serial) to the equipment, following the section 1.3 of this chapter, it is possible to communicate to the Merging Unit Device and receive an online equipment configuration, click on the <Receive> button on the initial screen of the Merging Unit Configurator. It opens the Main Screen of the Merging Unit Configurator, with the equipment configuration file loaded. To receive an equipment configuration file, it is necessary to be connected to the equipment.

It is also possible to receive an equipment configuration file through the Main Screen of the Merging Unit Configurator, by selecting the option Receive Configuration on the Communication menu.

After clicking the Receive button, an authentication window will pop up asking for a user and a password to complete the operation.

Only the users **CFG** and **ADM** are allowed for this operation.

---

## 5 Opening a Pre-existing Configuration File

In order to open a pre-existing configuration, click on the <Open> button on the initial screen of the MU320 Extended Configurator.

It opens the Windows© folder where the configuration files are saved:

Choose the configuration file and the Main Screen of the MU320 Extended Configurator will open, with the selected configuration file loaded.

It is also possible to open a configuration file from the Main Screen of the MU320 Extended Configurator, by selecting the option Open CID on the File menu.

---

## 6 Saving a Configuration File

To save an opened configuration, select the option Save CID or Save CID As, on the File menu of the Main Screen of the MU320 Extended Configurator.

---

## 7 Sending a Configuration File for the Equipment

After configuring the communication path (IP address or serial) to the equipment, following the section 1.3 of this chapter, it is possible to communicate to the Merging Unit Device and send a configuration file to online equipment. Select the option Send Configuration, on the Communication menu of the Main Screen of the Merging Unit Configurator.

---

## 8 LOG

The equipment maintains a history of the last 10000 system events that can be downloaded in from the MU320E. It is possible to access and download the Log file using the HMI menu of the MU320 Extended Configurator menu bar, by selecting the option Log. The logs visualization screen can show up to 2000 events.

Figure below shows a log file example.

```

*log_MU01_1292021_165043 - Bloco de Notas
Arquivo  Editar  Formatar  Exibir  Ajuda
MU320E
Date: 12/9/2021
Time: 16:50:48

Event ID      Date          Time          Code          Description
1             12/9/2021    16:50:05.410  L507          ICT requested log cleanup.
2             12/9/2021    16:50:27.175  L501          New configuration: [ok]
3             12/9/2021    16:50:27.426  LC03         Serial 1 settings changed to speed: 115200 bps, data bits: 8, parity: N, stop bits: 1
4             12/9/2021    16:50:27.449  LC03         Serial 1 settings changed to speed: 115200 bps, data bits: 8, parity: N, stop bits: 1
5             12/9/2021    16:50:27.489  LC03         Serial 0 settings changed to speed: 115200 bps, data bits: 8, parity: N, stop bits: 1
6             12/9/2021    16:50:29.341  L400         Time synch: [kind: holdover; grandmaster: f80278ffffe101f8d; source: PTP]
7             12/9/2021    16:50:32.001  L704         Binary input [name: Ind2] changed quality from [validity: good; quality: 0x0] to [validity: good; quality: 0x10]
8             12/9/2021    16:50:32.002  L704         Binary input [name: Ind3] changed quality from [validity: good; quality: 0x0] to [validity: good; quality: 0x10]
9             12/9/2021    16:50:32.003  L704         Binary input [name: Ind4] changed quality from [validity: good; quality: 0x0] to [validity: good; quality: 0x10]
10            12/9/2021    16:50:32.004  L704         Binary input [name: Ind5] changed quality from [validity: good; quality: 0x0] to [validity: good; quality: 0x10]
11            12/9/2021    16:50:32.005  L704         Binary input [name: Ind6] changed quality from [validity: good; quality: 0x0] to [validity: good; quality: 0x10]
12            12/9/2021    16:50:32.005  L704         Binary input [name: Ind7] changed quality from [validity: good; quality: 0x0] to [validity: good; quality: 0x10]
13            12/9/2021    16:50:32.006  L704         Binary input [name: Ind8] changed quality from [validity: good; quality: 0x0] to [validity: good; quality: 0x10]
14            12/9/2021    16:50:32.007  L704         Binary input [name: Ind9] changed quality from [validity: good; quality: 0x0] to [validity: good; quality: 0x10]
15            12/9/2021    16:50:32.008  L704         Binary input [name: Ind10] changed quality from [validity: good; quality: 0x0] to [validity: good; quality: 0x10]
16            12/9/2021    16:50:32.009  L704         Binary input [name: Ind11] changed quality from [validity: good; quality: 0x0] to [validity: good; quality: 0x10]
17            12/9/2021    16:50:32.010  L704         Binary input [name: Ind12] changed quality from [validity: good; quality: 0x0] to [validity: good; quality: 0x10]
18            12/9/2021    16:50:32.011  L704         Binary input [name: Ind13] changed quality from [validity: good; quality: 0x0] to [validity: good; quality: 0x10]
19            12/9/2021    16:50:32.011  L704         Binary input [name: Ind14] changed quality from [validity: good; quality: 0x0] to [validity: good; quality: 0x10]
20            12/9/2021    16:50:32.013  L704         Binary input [name: Ind15] changed quality from [validity: good; quality: 0x0] to [validity: good; quality: 0x10]
21            12/9/2021    16:50:32.013  L704         Binary input [name: Ind16] changed quality from [validity: good; quality: 0x0] to [validity: good; quality: 0x10]
22            12/9/2021    16:50:32.014  L704         Binary input [name: Ind17] changed quality from [validity: good; quality: 0x0] to [validity: good; quality: 0x10]
23            12/9/2021    16:50:32.015  L704         Binary input [name: Ind18] changed quality from [validity: good; quality: 0x0] to [validity: good; quality: 0x10]
24            12/9/2021    16:50:32.016  L704         Binary input [name: Ind19] changed quality from [validity: good; quality: 0x0] to [validity: good; quality: 0x10]
25            12/9/2021    16:50:32.017  L704         Binary input [name: Ind20] changed quality from [validity: good; quality: 0x0] to [validity: good; quality: 0x10]
26            12/9/2021    16:50:32.018  L704         Binary input [name: Ind21] changed quality from [validity: good; quality: 0x0] to [validity: good; quality: 0x10]
27            12/9/2021    16:50:32.019  L704         Binary input [name: Ind22] changed quality from [validity: good; quality: 0x0] to [validity: good; quality: 0x10]
28            12/9/2021    16:50:32.019  L704         Binary input [name: Ind23] changed quality from [validity: good; quality: 0x0] to [validity: good; quality: 0x10]
29            12/9/2021    16:50:32.020  L704         Binary input [name: Ind24] changed quality from [validity: good; quality: 0x0] to [validity: good; quality: 0x10]
30            12/9/2021    16:50:32.021  L704         Binary input [name: Ind25] changed quality from [validity: good; quality: 0x0] to [validity: good; quality: 0x10]
31            12/9/2021    16:50:32.022  L704         Binary input [name: Ind26] changed quality from [validity: good; quality: 0x0] to [validity: good; quality: 0x10]
32            12/9/2021    16:50:32.022  L704         Binary input [name: Ind27] changed quality from [validity: good; quality: 0x0] to [validity: good; quality: 0x10]
33            12/9/2021    16:50:32.023  L704         Binary input [name: Ind28] changed quality from [validity: good; quality: 0x0] to [validity: good; quality: 0x10]
34            12/9/2021    16:50:32.024  L704         Binary input [name: Ind29] changed quality from [validity: good; quality: 0x0] to [validity: good; quality: 0x10]
35            12/9/2021    16:50:32.025  L704         Binary input [name: Ind30] changed quality from [validity: good; quality: 0x0] to [validity: good; quality: 0x10]
36            12/9/2021    16:50:32.026  L704         Binary input [name: Ind31] changed quality from [validity: good; quality: 0x0] to [validity: good; quality: 0x10]
37            12/9/2021    16:50:32.027  L704         Binary input [name: Ind32] changed quality from [validity: good; quality: 0x0] to [validity: good; quality: 0x10]
38            12/9/2021    16:50:32.028  L704         Binary input [name: Ind33] changed quality from [validity: good; quality: 0x0] to [validity: good; quality: 0x10]
39            12/9/2021    16:50:32.029  L704         Binary input [name: Ind34] changed quality from [validity: good; quality: 0x0] to [validity: good; quality: 0x10]
40            12/9/2021    16:50:32.029  L704         Binary input [name: Ind35] changed quality from [validity: good; quality: 0x0] to [validity: good; quality: 0x10]
41            12/9/2021    16:50:32.030  L704         Binary input [name: Ind36] changed quality from [validity: good; quality: 0x0] to [validity: good; quality: 0x10]
42            12/9/2021    16:50:32.031  L704         Binary input [name: Ind37] changed quality from [validity: good; quality: 0x0] to [validity: good; quality: 0x10]
43            12/9/2021    16:50:32.032  L704         Binary input [name: Ind38] changed quality from [validity: good; quality: 0x0] to [validity: good; quality: 0x10]

```

Log file example

## 9 Configuration Tabs

### 9.1 IED Settings

IED tab allows the configuration of equipment identification, communication interface, and equipment synchronization, as described in the next sections.

#### 9.1.1 IDENTIFICATION

It is possible to configure the equipment identifier, location and owner using the Identification section. In this section the power system identification, the equipment operators, geographical position of the equipment and a master resource identification are configured as well.

The configuration fields are described below:

Identification	
Model	MU3203OB3B4B5XXP5MEBX04SE
Vendor	GE
Hardware Version	
Firmware Version	
Serial Number	
IED Name	<input type="text" value="IEDName"/>
Location	<input type="text" value="FLN"/>
Owner	<input type="text" value="GE"/>
Electric Power System	<input type="text"/>
Primary Operator	<input type="text"/>
Secondary Operator	<input type="text"/>
Master Resource Identification	<input type="text"/>
Latitude	<input type="text" value="0.0"/> °
Longitude	<input type="text" value="0.0"/> °
Altitude	<input type="text" value="0.0"/> m
<input type="button" value="Cancel"/> <input type="button" value="Ok"/>	

Software interface to configure Identification

- **Equipment information**
  - **Model:** indicates the equipment model;
  - **Vendor:** indicates the equipment manufacturer;
  - **Hardware Version:** indicates the current hardware version;
  - **Firmware Version:** indicates the current firmware version;
  - **Serial Number:** indicates the equipment serial number.
- **IED Name:** inserts the equipment identification code. The allowed characters are 0-9, a-z, A-Z and ' \_ '.
- **Location:** inserts the equipment location code. The allowed characters are 0-9, a-z, A-Z and ' \_ '.
- **Owner:** inserts the name of the company which purchased the equipment. The allowed characters are 0-9, a-z, A-Z and ' \_ '.
- **Electric Power System:** inserts the name of the electric power system that the equipment is connected to. The allowed characters are 0-9, a-z, A-Z and ' \_ '.
- **Primary Operator:** this text field allows to insert the name of the primary operator of the equipment. The allowed characters are 0-9, a-z, A-Z and ' \_ '.
- **Second Operator:** inserts the name of the second operator of the equipment. The allowed characters are 0-9, a-z, A-Z and ' \_ '.
- **Master Resource Identification:** inserts a unique identification of an asset or equipment. The allowed characters are 0-9, a-z, A-Z and ' \_ '.
- **Latitude:** inserts the geographical latitude coordinate position of device in WGS84. The range is from -90° to 90°.
- **Longitude:** inserts the geographical longitude coordinate position of device in WGS84. The range is from 0° to 180°.

- **Altitude:** inserts the geographical altitude coordinate position of device in WGS84. The range is from 0.0 m to 10000.0 m.

---

## 9.1.2 NETWORK

### 9.1.2.1 COMMUNICATION

This option depends on the CORTEC of the device. It allows the configuration of the network redundancy.

Two option can be set: *PRP* and *None*

When PRP is selected both Ethernet ports (1 and 2) will be enabled to: Sampled Values, GOOSE, PTPv2, MMS and configuration

When None is selected the Ethernet port 1 will be enabled to: Sampled Values, GOOSE, PTPv2, MMS and configuration. And the Ethernet port 2: MMS and configuration.

This same screen shows the fixed configurations to communicate to the maintenance serial port (RS-232).

The parameters available to configure the Ethernet interfaces are:

- **Ethernet IP Address:** inserts the IP address of the Ethernet 1 interface (station bus). For information about the default IP address, refer to Chapter 6: Communication – 1.1 Ethernet Ports Default IP Address.
- **Ethernet Network Mask:** inserts the sub-network mask to which the equipment is connected.
- **Gateway IP Address:** inserts the IP address of the gateway of the local network to which the equipment is connected. For information about the gateway default IP address.

The IP address and gateway address of each port must be within the same subnet range to the software can validate the configuration. Note that Ethernet 1 and 2 IP addresses cannot be within the same subnet range.

**Note:**

MU320E Ethernet ports are not designed to receive high throughput. In case high throughput excessive processing might cause instable and undesirable synch behavior for MU320E.

Messages with the Ethertype 88-BA (Sampled Values) will be filtered by the MU320E to avoid processing these kinds of messages to improve performance.

Please apply multicast filtering or VLAN segregation networking techniques through managed switches to improve MU320E performance.

## 9.1.3 SYNCHRONIZATION

The MU320E supports time synchronization with PTP IEEE1588v2, demodulated IRIGB and you can also configure the option *Without sync* to disable the time sync.

It is possible to configure the MU320E to use the same time zone as the source synchronization signal or to configure the time zone locally. The MU320E also allows the configuration of the daylight saving time. These configurations are used to time stamp the log file.

### 9.1.3.1 TIME SOURCE

This screen configures which signal will be used to time sync: IRIGB, PTP or without external source of synchronization.

IRIGB option does not have any parameters to configure.

PTP option allows two profile options:

- The POWER profile (IEEE C37.238-2011) has all its parameters pre-set and they cannot be altered. The parameters are the follow:
  - Network Protocol: Ethernet Level 2;
  - Delay Mechanism: Peer-to-peer;
  - Announce Receipt Timeout: 3
- The CUSTOM profile has all its parameters opened for user configuration.

Configurable parameters are:

- **Domain number:** A PTP domain is a collection of one or more PTP subdomains. A subdomain is a logical grouping of IEEE 1588 clocks that synchronize to each other using the PTP protocol, but that are not necessarily synchronized to PTP clocks in another PTP subdomain. Subdomains provide a way of implementing disjoint sets of clocks, sharing a common network, but maintaining independent synchronization within each set. The domain number can be set from 0 - 255.
- **Network protocol:** allows the user to choose between the UDP protocol and Ethernet layer 2.

Note:

MU320E will answer path delays requests always in **two-step** mode and will process the other PTP messages (sync, announce, etc) depending on the arriving mode. Therefore, for better performance with PTP source for MU320E it is recommended to have all devices involved in **Two-step** operation mode.

- **Delay Mechanism:** Defines which PTP delay mechanism is to be used for propagation delay measurement. The options are:
  - **End-to-end:** In this mode, the slave sends a *delay\_req* message to the master who replies with a *delay\_resp* message containing the timestamp of the arrival of the *delay\_req* message. Propagation delay is calculated with sync and *delay\_req* timestamps. Recommended when not all network elements are PTP aware.
  - **Peer-to-peer:** In this method the slave calculates the propagation delay only on the link to the peer directly connected to it. The calculation is based

on the exchange of *pdelay\_req* and *pdelay\_resp* messages, in both directions. For better performance, it is expected that all network elements calculate the link delay to the peers directly connected to them, and add the delay, along with the residence time, to the correction field of PTP event messages. Strongly recommended when all network elements are PTP aware.

- 
- **Announce Receipt Timeout:** Is the maximum period between announce packets from the same master that MU320E tolerates. When this value is exceeded the MU320E discard the Master Time in seconds.

### 9.1.3.2 LOCAL TIME SETTINGS

Allows the configuration of the time zone. It can be set as the same of the source time signal or it can be adjusted locally. Also allows configuring the daylight saving time. If the IRIG-B signal has the CF extensions (IEEE1344), timing information as date, hour, year, time zone and daylight saving time can be provided by the signal. In the Time Source section, it is possible to insert the source timing parameters, such as a satellite synchronized clock.

### 9.1.3.3 ETHERNET NETWORK SYNCHRONISM RECOMMENDATIONS

In order to obtain the best synchronism performance in a Ethernet network, the following configuration is recommended.

- PTP Power Profile (IEEE C37.238);
  - Delay mechanism: Peer-to-Peer ( P2P)
    - This means that ALL equipment (Switches, GPS clocks, Merging Units, Relays, Bay Controllers, and so on) must be PTP-aware.
  - Mapped as Ethernet ( Layer 2 – L2) messages
    - This means that ALL equipment (Switches, Merging Units, Relays, Bay Controllers, and so on) must be PTP-aware.
  - Two-step operation
    - Time is stamped preferentially at hardware.
- Max number of hops: 16
- Max error introduced by hop: 50ns
- Max error in slave: 1us
- Multicast filtering or VLAN segregation shall be configured in the managed switches, otherwise the MU320E might show instability and undesirable behavior in its applications and synchronism.

## 9.1.4 MODE/BEHAVIOR

On this screen it is possible to configure the MU320E according to the mode and behavior described in IEC 61850-7-4 edition 2.

The configuration of the mode/behavior is carried out by controlling the Data Attribute *Oper* in the Data Object Mod in the LN *LLNO* of the MU320E Logical Devices (LD).

The mode/behavior can be configured using the MU320 Extended Configurator software, by MMS command or by binary inputs.

Chapter 5: Operation, Section 6 MMS shows the address to configure the mode/behavior via MMS.

The figure below shows the configuration window.

LD	Mode	Behavior
BASE	On	On
MU01	On	On
MU02	On	On
CTRL	On	On

*Mode/Behavior configuration*

On the screen above: altering the mode of the LD BASE will influence the mode/behavior of all the other LD. The MU01 and MU02 will affect the Sampled Values transmission of the respective LD and the CTRL will alter the configuration of the GOOSE publisher and subscriber.

The table bellows describes each type of Mode/Behavior and the status of the test bit.

Mode	Description	Quality bit
On	The application represented by the LN and all communication services work properly	test=false
Blocked	The application represented by the LN works. No output data (digital by relays or analogue setting) will be issued to the process. All communication services work and get updated values. Control commands will be rejected.	test=false
Test	The application represented by the LN works. All communication services work and get updated values. Data objects will be transmitted with quality "test". Control commands with quality test will be accepted only by LNs in "test" or "test-blocked" mode.	test=true
Test/Blocked	The application represented by the LN works. No output data (digital by relays or analogue setting) will be issued to the process. All communication services work and get updated values. Data objects will be transmitted with quality "test". Control commands with quality test will be accepted only by LNs in test or test-blocked mode.	test=true
Off	The application represented by the LN does not work. No process output is possible. No control command is acknowledged (negative response). Turns off SV streams, MMS updates and responses. Only the data object Mod and Beh should be accessible by the services.	Validity=invalid

Altering the Mode/Behavior will cause effects in the MU320E publishing and subscribing. Below is described the behavior of each service according to the Mode/Behavior of the LD in the MU320E.

**Controlling the Mode/Behavior via binary inputs**

It is possible to configure which binary input will correspond to the Test input and the Blocked input. The table below shows the Mode/Behavior of the MU320E according to the state of the Test and Binary inputs configured.

Test	Blocked	Mode/Behavior
0	0	On
0	1	Blocked
1	0	Test
1	1	Test Blocked

**Note:**

*Whenever the device's Mod is modified via binary input and the same input is assigned to a dataset, the FastGOOSE will send first the binary state and then the change in the quality.*

### Goose Subscriber

The table bellows shows the MU320E outputs and MMS command acceptance behavior for each Mode/Behavior depending the status of the quality bit of the incoming GOOSE message.

Mode/Behavior	Quality received in the message	Operates output?	Update Data Model?
on	q.test=false	Y	Y
on	q.test=true	N	N
blocked	q.test=false	N	Y
blocked	q.test=true	N	N
test	q.test=false	Y	Y
test	q.test=true	Y	Y
test-blocked	q.test=false	N	N

### Goose and Sampled Values Publisher

The table below shows the behavior of the messages for each Mode/Behavior

Device Mode/Behavior	Changes in the message frame
on	None
blocked	None
test	Sets quality bit test to true (test=true)
test-blocked	Sets quality bit test to true (test=true)
off	Disables the transmission

## 9.1.5 SIMULATED MESSAGES

When this mode is enabled the MU320E will operate normally until the moment it receives the first message with the Simulation bit=**TRUE**. From that moment onwards it will consider only the messages with the Simulation bit asserted and neglect the messages with the test bit off. The interpretation of simulated GOOSE messages is independent for each GOOSE Control Block being read, i.e., if the MU320E is receiving on GOOSE-1 and GOOSE-2 Inputs real GOOSE from Control Block A and on GOOSE-3 and GOOSE-4 Inputs Simulated GOOSE, the processing of the Real GOOSE-1 and GOOSE-2 will remain the same no matter what happens to GOOSE-2.

In order for the MU320E to turn off the Receive simulated messages and come back to normal operation it is necessary to deactivate the Sim Data Object either via MMS in `<MU320BASE>LPHD>CO>Sim>Oper` or sending a new configuration using the MU320 Configurator software.

Chapter 5: Operation, Section 6 MMS shows the address to configure the Simulated messages reception via MMS.

## 9.1.6 VT FUSE FAILURE

Configures which binary inputs will be connected to the VT fuse failure status for each phase of the logical devices MU01 and MU02. Whenever the VT fuse failures inputs configured are activated the quality bits “failure”, of the respective sampled values frame, will be set to “true” and the “validity” will be set to “invalid”.

## 9.2 Power System Settings

MU320E allows monitoring two power systems individually through slots G and H. Power System tab allows the configuration of each power system separately.

The MU01 section defines the power system parameters of the circuit connected to the Slot G. The MU02 section has the same settings that the circuit connected to the Slot H.

The configurable parameters are described below:

Section	Parameter	Value	Unit
A	Nominal Frequency	60 Hz	
	Nominal Primary Current	1000	A
	Nominal Primary Voltage	115000	V
B	Phase CTs Ratio (Ia, Ib and Ic)	200.0	
	Ground/Neutral CT Ratio (In)	200.0	Measured
C	Phase VT Ratio (Va, Vb and Vc)	1000.0	
	Aux/Neutral VT Ratio (Vn)	1000.0	Measured
D	Instantaneous Current Value - Scale Factor	0.001	
	Instantaneous Current Value - Offset	0.000	
E	Instantaneous Voltage Value - Scale Factor	0.010	
	Instantaneous Voltage Value - Offset	0.000	

Power System Configuration Tab

### A Nominal Values

- Nominal Frequency: selects the system nominal frequency that can be 50 Hz or 60 Hz.
- Nominal Primary Current: inserts the nominal primary current of the system. The range is from 1 A to 1.000.000 A.

- Nominal Primary Voltage: inserts the nominal primary voltage of the system. The range is from 1 V to 1.000.000 V.

#### B CT's

- Current TR Phase ( $I_a$ ,  $I_b$  and  $I_c$ ): inserts the current transformers values. The range is from 1 - 35.000 for board model **ME** and **P1** and 1 - 7.000 for board model **P5**.
- Current TR Neutral ( $I_n$ ): inserts the current transformers values. The range is from 1 - 35.000 for board model **ME** and **P1** and 1 - 7.000 for board model **P5**.

#### C VT's

- Voltage TR Phase ( $V_a$ ,  $V_b$  and  $V_c$ ): inserts the voltage transformers values. The range is 1 -10.000.
- Voltage TR Neutral ( $V_n$ ): inserts the voltage transformers values. The range is 1 - 10.000.

#### D and E Instantaneous Current Values/Instantaneous Voltage Values

- Scale Factor and Offset are floating points defined by the IEC 61850-7-3 and have their values fixed by the IEC 61850-9-2L2. The Scale Factor is always set to 0.001 and the Offset to 0.01.
- The values transmitted in the SV packet are integers and the Scale Factor and the Offset are used to translate the sent values to the actual system values using the following formula:

$$\text{System primary value} = i \times \text{scale factor} + \text{offset}$$

$i$  = integer representation of the measured value

## 9.3 Sampled Values Settings

MU320E allows monitoring two power system individually through the slots G and H. Sampled Values tab allows the configuration of each protection power system Sampled Values separately.

The merging unit MU320E can publish two kinds (streams) of sampled values profiles: Protection profile (80 ppc) and Measurement profile (256 ppc grouped in 32 frames with 8 points).

The MU320E has two logical devices called MU01 and MU02, the MU01 uses the signals acquired by the slot G and the MU02 uses the signals acquired by the slot H.

The MU320E can send up to two different streams of data at the same time, regardless of the logical device it belongs, i.e., MU01 and MU02 have one Protection and one Measurement profile each, amounting to 4 different profiles. It is possible to use two of these profiles at the same time.

### 9.3.1 PROTECTION PROFILE

The MU01 Protection section defines the Sampled Values parameters of the circuit connected to the Slot G. If the MU320E has the Slot H installed a section named "MU02" will appear.

The configurable parameters are described below:

Sampled Values Screen Configuration

**A Enable:** this check-box allows enables the Sampled Values messages transmission.

**B Transmission Identification**

- **Message Name:** inserts a name for the Sampled Value Control Block. The allowed characters are 0-9, a-z, A-Z and ‘\_’.
- **Description:** inserts a description for the Sampled Values. The not allowed characters are ‘<’ and ‘>’.
- **SV ID:** inserts an identification for the Sampled Values. The allowed characters are 0-9, a-z, A-Z, ‘\_’ and ‘.’, limited to 32 chars.
- **Dataset:** selects the dataset for the Sampled Values.
- **Message Type:** fixed as multicast.
- **Sample Rate:** for the protection profile the sample rate is 80 ppc.
- **Number of ASDUs:** for the protection profile the ASDU number is 1.

**C Options**

- **Data Reference:** When enabled, the dataset name sent by this Sampled Value Control Block is inserted in the SV protocol frame.
- **Sample Rate:** When enabled, the sample rate of the acquisition system is inserted in the SV protocol frame (80 ppc for protection).
- **Sample Synchronized:** When enabled, the *SmpSynch* information is inserted in the SV protocol frame. The *SmpSynch* informs if the samples are synchronized through GPS satellites time sources, or through non-referenced GPS satellites time sources, or not synchronized.

According to 9-2 Light Edition, only the *SmpSynch* is inserted on the Sampled Values protocol data frame.

#### D Network Settings

- **APP ID:** inserts an indication of the message identifier. The identifier must contain four hexadecimal characters from 0x4000 to 0x7FFF.
- **MAC-Address:** inserts an indication of the MAC address of the originator to be filtered. The address must be represented as six groups of hexadecimal characters. The allowed characters are 0-9, a-z, A-Z and '-'. IEC 61850-8-1 standard recommends the MAC address for GOOSE messages creation as following:
  - The first three bytes are 01-0C-CD;
  - The fourth byte must be 04 for Sampled Values;
  - Thus it is recommended MAC address to be configured within the range from 01-0C-CD-04-00-00 to 01-0C-CD-04-01-FF.
- **VLAN-PRIORITY:** selects the VLAN priority. Such priority must be a numeric value between 0 and 7.
- **VLAN-ID:** inserts the VLAN unique identification from 0 to 4095.

<Ok>: this button confirms the Sampled Values edition.

<Cancel>: this button cancels the Sampled Values edition and return to the main screen of the Merging Unit Configurator.

**Note:**

Message Name must follow the name pattern **MSVCBxx** to be compliant to the IEC 61850-9-2LE.

## 9.3.2 MEASUREMENT PROFILE

The measurement profile configuration has the same options as the protection profile explained in the previous topic.

## 9.4 Binary Settings

To simplify even more MU320E configuration, this tab allows the user to configure general parameters related to binaries under the tab *Binary*, as shown in the figure below.

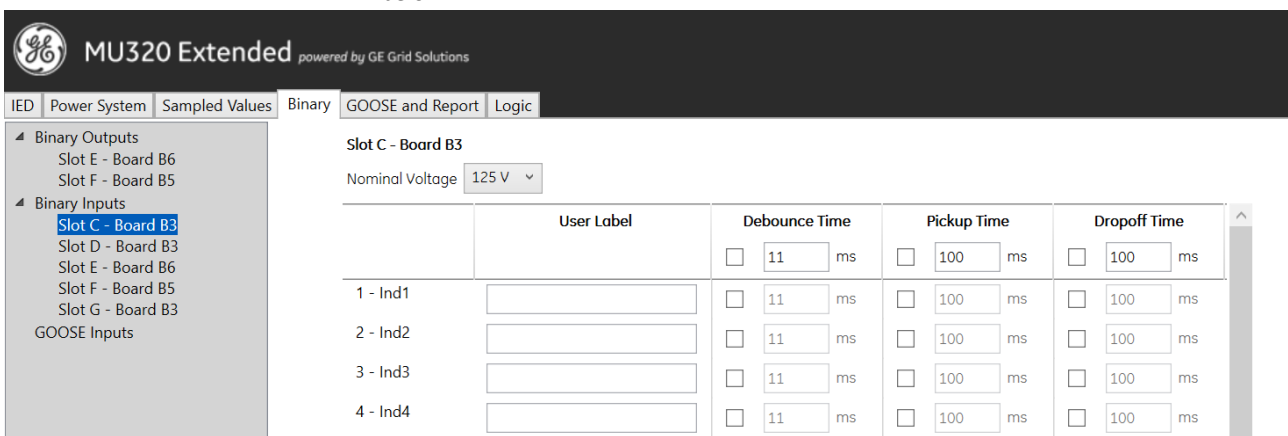

Binary tab

In this tab it is possible to access the following items in the left tree:

- **Binary Outputs:** Allows the access to the user label configuration for all binary outputs organized by slot and board model.
- **Binary Inputs:** Allows the access to:
  - User label configuration for all binary outputs organized by slot and board model.
  - Select the voltage level (24V, 48V, 125V and 250V) for each slot. The default nominal voltage is 125V
  - Define debouncing, pickup and dropoff configuration for all binary inputs
- **GOOSE Inputs:** Allows the access to the user label configuration and behavior when communication is lost for all GOOSE inputs.

## 9.4.1 USER LABELS

Labels are important to users making easier to correlate IEC 61850 and MU320E nomenclature to what is being used by the application and facilitate logic screen configuration and HMI monitoring.

These user labels can be used, for example, to easily identify what is binary output to be connected to the open coil of certain Circuit Breaker.

The screenshot displays the MU320 Extended software interface. At the top, the GE logo and 'MU320 Extended powered by GE Grid Solutions' are visible. Below the title bar, there are tabs for 'IED', 'Power System', 'Sampled Values', 'Binary', 'GOOSE and Report', and 'Logic'. The 'Binary' tab is active. On the left, a tree view (labeled A) shows a hierarchy of 'Binary Outputs' and 'Binary Inputs'. Under 'Binary Outputs', 'Slot E - Board B6' is selected. The main configuration area (labeled B) is titled 'Slot E - Board B6'. It contains a table with two columns: 'Binary Output' and 'User Label'. The 'Binary Output' column lists eight channels: 1 - Ind33, 2 - Ind34, 3 - Ind35, 4 - Ind36, 5 - Ind37, 6 - Ind38, 7 - Ind39, and 8 - Ind40. The 'User Label' column contains eight empty text input fields (labeled D). A vertical line (labeled C) is positioned between the two columns.

User Label configuration

**A Binary Selection:** This tree allows to select the group of binary input, output or GOOSE input to be configured.

**B Selected Group:** Shows the selected group by slot and board model or GOOSE Input.

**C Binary Channel:** List of binary channels to receive the label. For each channel it is also shown the IEC 61860 data object (*IndX*) associated to that channel state.

**D User Label Field:** Field to write the user label for the binary channel. It is allowed the maximum of 12 characters containing 0-9, a-z, A-Z and ' \_ '.

**<Ok>:** Confirms user labels edition.

**<Cancel>:** Cancels user labels edition and returns to the main screen of the Merging Unit Configurator.

## 9.4.2 BINARY INPUT CONFIGURATIONS

With MU320E it is possible to select the nominal voltage level for each binary input board. The figure below shows the screen after the selection of one Binary Input group, with the option to configure:

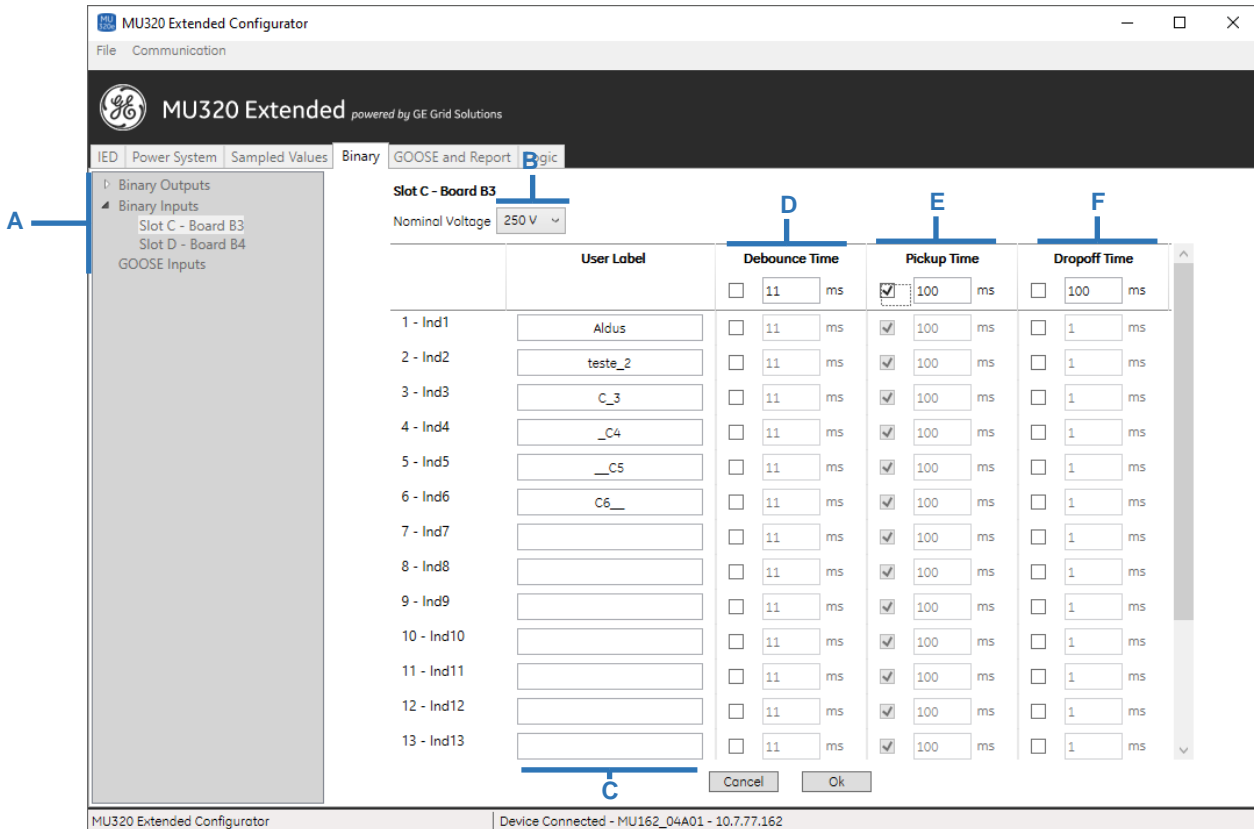

Binary Input Configurations

- **A:** Tree that allows to select the group of binary input, output or GOOSE input to be configured.
- **B:** Options to configure the nominal voltage for the binary inputs of a certain module. Options 24V, 48V, 125V and 250V, valid for all binary inputs in that group.
- **C:** Configures the user labels described in section 9.4.1 of this chapter.
- **D:** Configures debounce for the binary input. It is possible to enable/disable debounce and define its time from 1 – 1000ms, being 11ms the default value. It is possible to simultaneously configure debounce for all inputs in the slot by setting it up on the header of the configuration table.
- **E:** Configures pickup time for the binary input. It is possible to enable/disable this behavior and define its time from 1ms – 60000ms, being 100ms the default value. It is possible to simultaneously configure pickup for all inputs in the slot by setting it up on the header of the configuration table.
- **F:** Configures dropoff time for the binary input. It is possible to enable/disable this behavior and define its time from 1ms – 60000ms, being 100ms the default value. It is possible to simultaneously configure dropoff for all inputs in the slot by setting it up on the header of the configuration table.

Debounce time is the minimum time that a binary input must keep the new state to be considered a binary input change status event. In this case, the event will be interpreted and timestamped only after the debounce time.

### 9.4.3 GOOSE INPUTS

Under the three *GOOSE Inputs*, in the tab *Binary* It is possible to select naming and behavior of the 32 virtual GOOSE inputs available in MU320E, as shown in the figure below, allowing to configure:

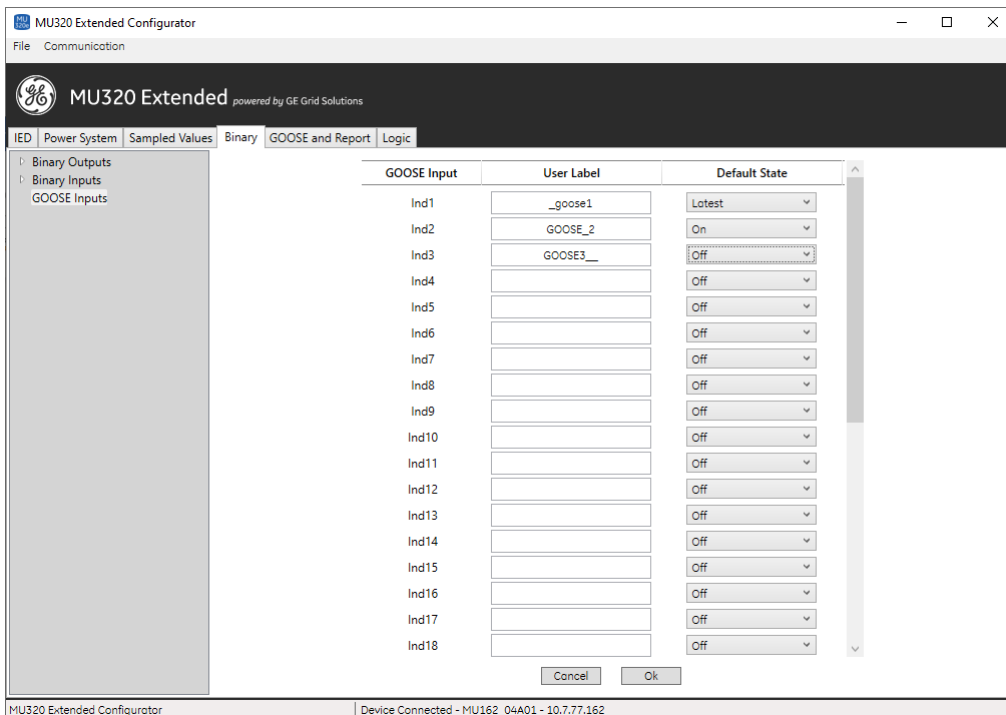

*GOOSE Inputs Configuration*

- **User Label:** Input field up to 12 characters allowing to give non-standard names for GOOSE inputs. This information will be visible in the HMI and is readable through MMS.
- **Default State:** This field allows to determine what shall be the status of the GOOSE input in case it is not possible to establish communication with the configured control block. This might occur due to invalid configuration or communication issues and in these cases the GOOSE input shall be marked with quality as substituted and will assume one of the following behaviors:
  - **Latest:** maintain the latest value before losing communication
  - **On:** assumes the status On after losing communication
  - **Off:** assumes the status Off after losing communication

## 9.5 GOOSE and Report Settings

MU320E may publish and subscribe to GOOSE messages and publish Report control blocks according to IEC61850-8-1 standard. To subscribe to GOOSE messages, it is necessary to configure the association between the GOOSE messages and digital channels. To publish GOOSE messages and report control blocks, it is necessary to create datasets and configure the transmission parameters.



**Note:**

The message being read can be Type 1A, 1B, 2 or 3, within the MU320E they are all treated within the parameters of performance of messages Type 1A with performance class P1, which means that their transfer time is less than 3ms.

### 9.5.1 CREATING A DATASET

The Dataset section is used to create a dataset for GOOSE messages transmission. The configurable parameters are described below:

Dataset Configuration Screen

**A** This area lists all created datasets.

**B** Datasets buttons:

- **<New>**: this button creates a new dataset. Clicking on this button, the dataset parameters will appear for editing.
- **<Edit>**: this button edits a selected pre-existing dataset. Clicking on this button, the dataset parameters will appear for editing.
- **<Delete>**: this button deletes a selected pre-existing dataset. The DigInput1 dataset cannot be deleted.

**C** Functional Constraint: selects the functional constraint that indicates the possible operating services of a specific DataAttribute. The functional constraints are:

- ST: Status Information;
- MX: Measurements;
- CO: Control;
- SP: Setting Point;
- CF: Configuration
- DC: Description
- EX: Extended Definition

**D** Dataset Name: inserts a name for the new dataset.

**E** Description: inserts a description for the new dataset.

**F** Filter: enables the user to filter the global dataset by DataAttribute/DataObject names.

**G** Transfer area of available DataAttribute/DataObject to datasets.

**H** Dataset selected DataAttribute/DataObject.

**I** Buttons **<<** and **>>** to remove or add DataAttribute/DataObject to Dataset.

**J** Buttons **^** and **v** to organize the position of DataAttribute/DataObject on Dataset.

**<Ok>**: this button confirms the dataset edition.

**<Cancel>**: this button cancels the dataset edition and returns to the main screen of the Merging Unit Configurator.

There is a preset dataset that groups all the Binary inputs of the device. This dataset is used in the FastGOOSE messages.

## 9.5.2 SUBSCRIBING TO GOOSE MESSAGES

The MU320E has 32 virtual binary inputs that can be associated with GOOSE Booleans values.

It is possible to associate up to 32 GOOSE Control Block with individually supervision through special Logical Node (LGOS) available in data model.

The configurable parameters are described below:

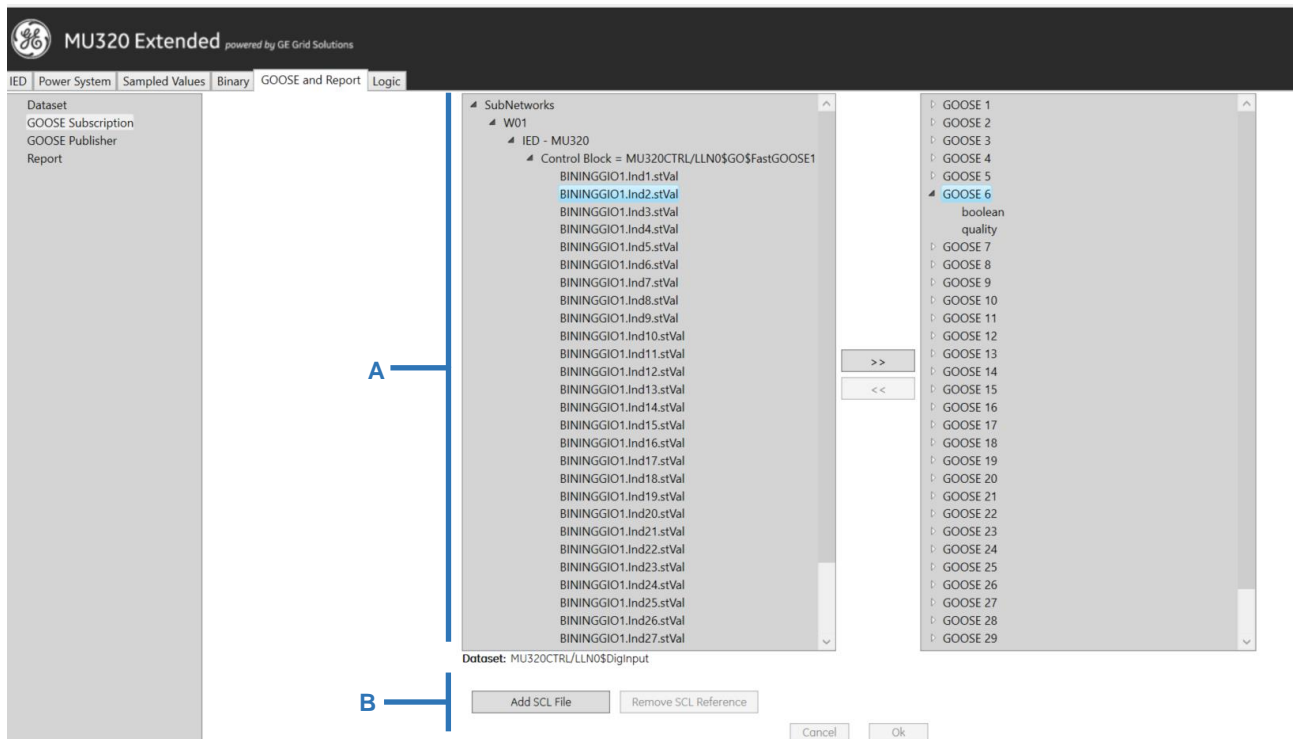

GOOSE Subscription Configuration Screen

**A** Association area used for GOOSE messages and digital inputs. To associate a GOOSE Control Block to a digital input, do the following:

- 1- Initially select a GOOSE binary element from the Devices list, obtained from the SCL files generated by IED.
- 2- Select one of the 32 digital inputs.
- 3- Clicking on the button will associate the GOOSE message with the previously selected digital input.
- 4- To remove the association, click on the disassociate button.

**B SCL management area:** Button to add and remove SCL files to the devices list.

**<Ok>:** this button confirms the GOOSE messages receiving edition.

**<Cancel>:** this button cancels the GOOSE messages receiving edition and returns to the main screen of the Merging Unit Configurator.

### 9.5.3 PUBLISHING GOOSE MESSAGES

To transmit GOOSE messages grouped on dataset, it is necessary to create a GOOSE Control Block (GCB). In the Transmit section it is possible creating and editing GOOSE Control Block for the GOOSE messages transmission.

Each GCB is associated to one Dataset and the MU320E can send up to 32 GCB.

The configurable parameters are described below:

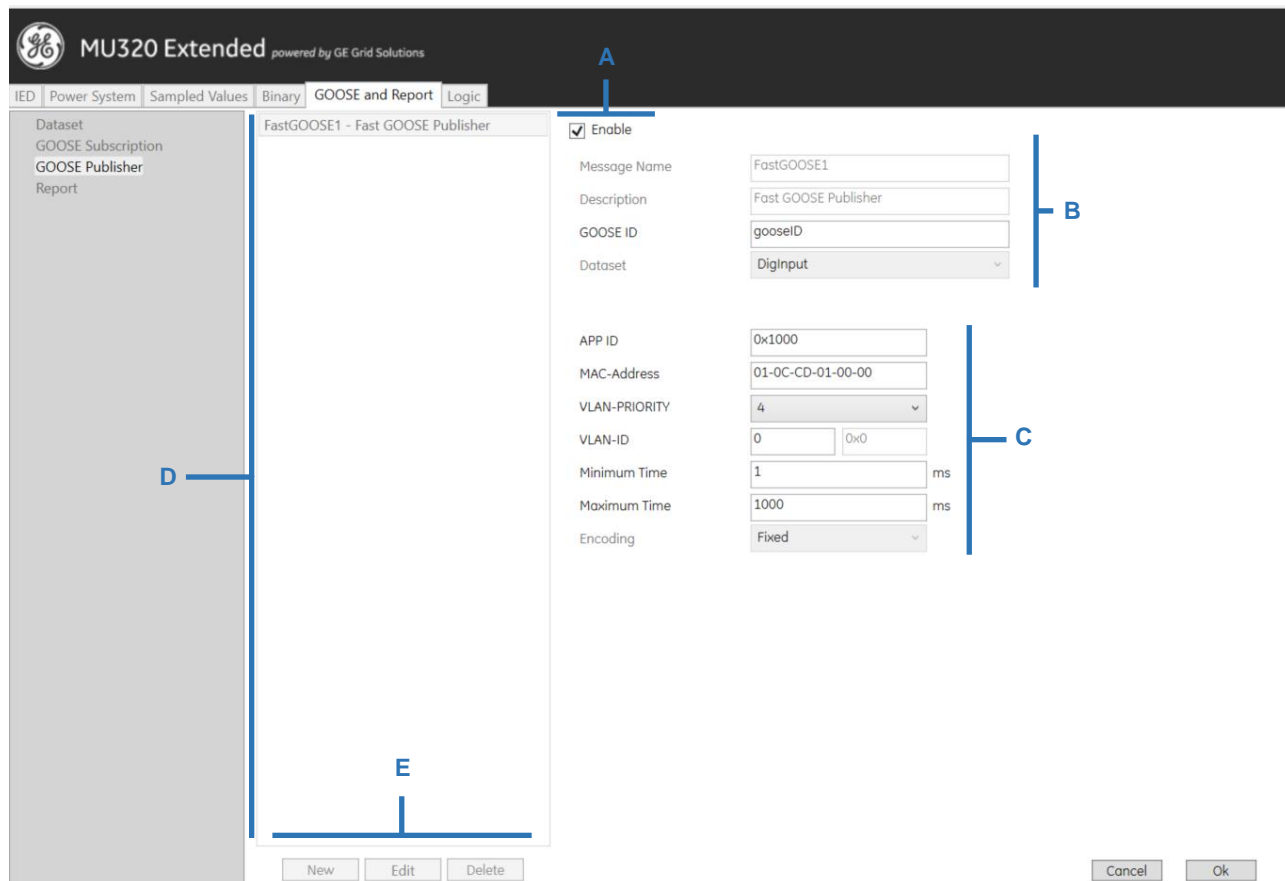

GOOSE Publisher Configuration Screen

**A Enable:** this check-box enables the publication of the respective GOOSE Control Block.

**B GOOSE Control Block Identification**

- **Message Name:** inserts a name for the GOOSE Control Block. The allowed characters are 0-9, a-z, A-Z and ' \_'.
- **Description:** inserts a description for the GOOSE Control Block. The not allowed characters are '<' and '>'.
- **GOOSE ID:** inserts an identification for the GOOSE Control Block. The allowed characters are 0-9, a-z, A-Z and ' \_'.
- **Dataset:** selects the dataset for this GOOSE Control Block. In this field will appear all created datasets.

**C Network Settings**

**APP ID:** inserts an indication of the message identifier. The identifier must contain four hexadecimal characters. The allowed characters are 0-9, a-z, A-Z and ' \_'.

**MAC-Address:** inserts an indication of the MAC address of the originator to be filtered. The address must be represented as six groups of hexadecimal characters. The allowed

characters are 0-9, a-z, A-Z and ‘\_’. IEC 61850-8-1 standard recommends the MAC address for GOOSE messages creation as following:

- The first three bytes are 01-0C-CD;
- The fourth byte must be 01 for GOOSE;
- Thus it is recommended MAC address to be configured within the range from 01-0C-CD-01-00-00 to 01-0C-CD-01-01-FF.
- **VLAN-PRIORITY:** selects the VLAN priority. Such priority must be a numeric value between 0 and 7.
- **VLAN-ID:** inserts the VLAN unique identification from 0 to 4095.
- **Minimum Time:** inserts the maximum delay time allowed for message transmission, after the change of the state. The range is from 20 ms to 60000 ms.
- **Maximum Time:** inserts the source supervision time. If there is none change of state, a message is transmitted in this time. The range is from 20 ms to 60000 ms.

**D** This area list all created GOOSE Control Blocks.

**E** Datasets manipulation buttons:

- <New>: this button creates a new GOOSE Control Block. Clicking on this button, the GOOSE Control Block parameters will appear for editing.
- <Edit>: this button edits and selects pre-existing GOOSE Control Block. Clicking on this button, the GOOSE Control Block parameters will appear for editing.
- <Delete>: this button deletes a selected pre-existing GOOSE Control Block.

**<Ok>:** this button confirms the GOOSE Control Block edition.

**<Cancel>:** this button cancels the GOOSE Control Block edition and returns to the main screen of the Merging Unit Configurator.

The GCB01 is the Control Block that represents the FastGOOSE, with the status of Binary Inputs. It can be edited and disabled, but not deleted.



**Note:**

- 1- *In case the standard GOOSE publisher is being used instead of the FastGOOSE the minimum value for the parameter “Minimum Time” shall be 10 ms in order to allow that GOOSE messages with a sufficiently large TimeAllowedToLive parameter are being sent.*
- 2- *Analog measurements cannot be sent via GOOSE.*

## 9.5.4 PUBLISHING REPORT CONTROL BLOCKS

This screen allows the user to configure the Report Control Blocks (RCB). The Report Control Block sends internal variables grouped on a datasheet to the supervisory system. Each RCB is associated to one Dataset and the MU320E can send up to 16 buffered or unbuffered Report Control Blocks.

The configurable parameters are described below:

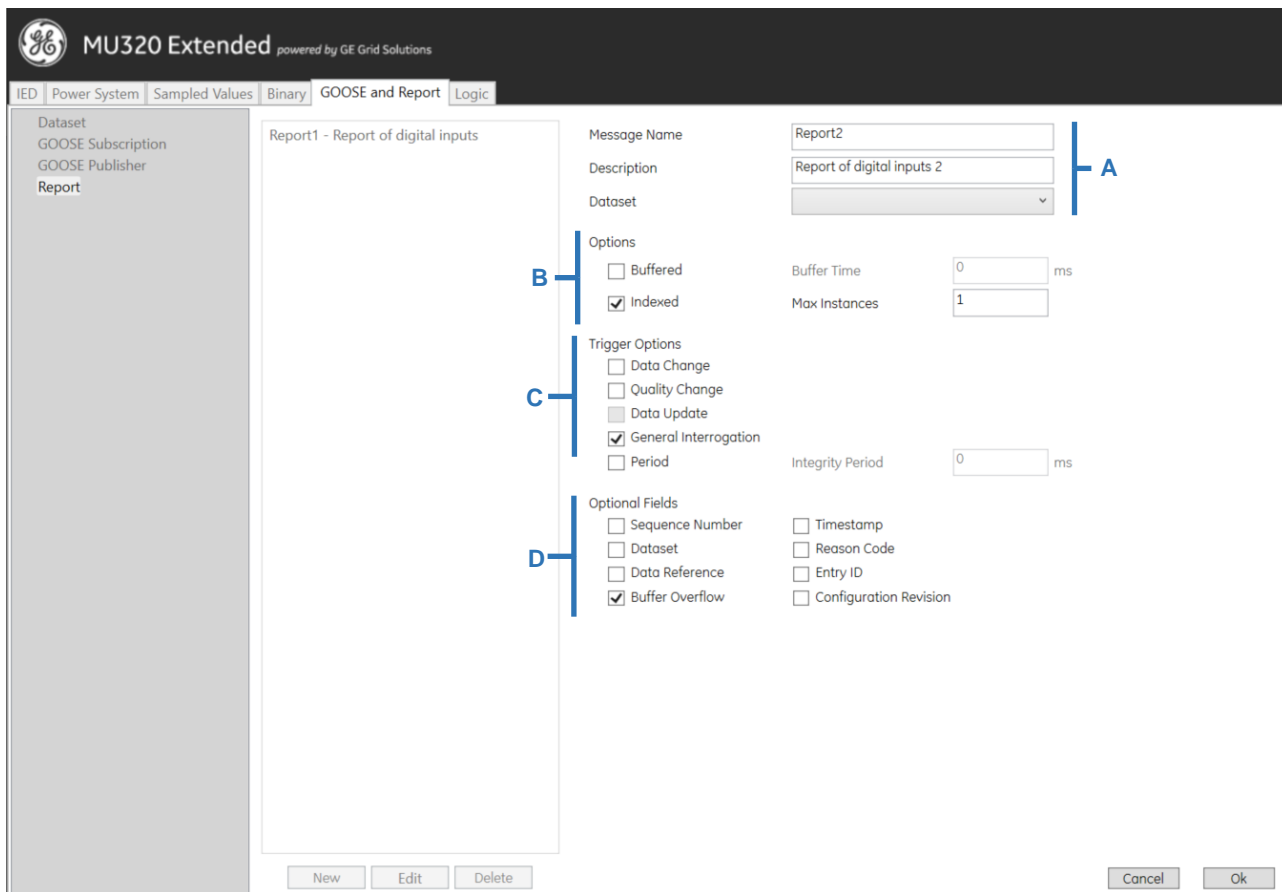

GOOSE Publisher Configuration Screen

**A Report Control Block Identification and data**

- Message Name: inserts a name for the GOOSE Control Block. The allowed characters are 0-9, a-z, A-Z and ‘\_’.
- Description: inserts a description for the GOOSE Control Block. The not allowed characters are ‘<’ and ‘>’.
- Dataset: selects the dataset for this Report Control Block. In this field will appear all created datasets.

**B Options**

- Buffered: internal events (caused by trigger options data-change, quality-change, and data-update) issue immediate sending of reports or buffer the events (to some practical limit) for transmission, such that values of data object are not lost due to transport flow control constraints or loss of connection.
- Buffered Time: specifies the time interval in milliseconds for the buffering of internal notifications caused by data-change (dchg), quality-change (qchg), dataupdate (dupd) by the BRCB for inclusion into a single report. Upon receipt of the first set of internal notification of events of the referenced data-set, the BRCB starts a timer of the duration buffer time. When the timer expires, the BRCB combines all internal notifications that have been received during the time interval into a single report. The next internal notification following the timer expiration signals the new start of that timer. Range: 1 – 3600000 ms. Step 1 ms;

- Indexed: When checked the report control block instance names are created from the RCB name, followed by an index number from 01 up to maximum 16.
- Max Instances: To allow multiple clients to receive the same values of data object, multiple instances of the report control classes shall be made available. Once a report control block is reserved, by a specific client, no other client shall have access rights to set the control block attributes. Up to 16 instances can be configured.

**C Trigger Options:** Specifies the trigger conditions which will be monitored by this BRCB. The following values are defined:

- **Data Change(dchg):** relates to a change in a value of a DataAttribute representing the process-related value of the data object
- **Quality Change(qchg):** relates to a change in the quality value of a DataAttribute.
- **Data Update (dupd):** relates to a freeze event in a value of a DataAttribute representing a freeze value of the data object (for example, frozen counters) or to an event triggered by updating the value of a DataAttribute. Data-update trigger condition may be used to issue sending a report or storing a log entry into a log when a value of a DataAttribute has updated. Updating may mean that the value has changed or has been “overwritten” with the same value as before. The dupd trigger condition can be used as a trigger for statistics values that may be calculated and updated on a periodic base. Independently of whether the statistics value has changed or not, the value will be reported or logged.
- **General Interrogation:** After a request for General Interrogation the BRCB starts the interrogation process and create a report that includes all DataAttribute values of the referenced dataset.
- **Integrity:** When integrity reports are enabled, the BRCB shall be notified each time the value of the time as specified in Integrity Period has expired. The BRCB then builds a report with the values of all members of the referenced data-set.

Note: The general-interrogation is initiated by the client. The integrity report, which also transmits all values of a data set, is initiated by the BRCB.

**D Optional Fields:**

- Sequence Number: Includes the SqNum in the report. The attribute SqNum specifies the sequence number for each BRCB that has report enable set to TRUE. This number is incremented by the BRCB for each report generated and sent.
- Reason Code: Includes the ReasonCodes in the report, which means the reason that generated the report according to Trigger Options
- Dataset: Includes DatSets in the report
- Data Reference: Includes the DataRef in the report
- Time Stamp: Includes the time stamp in the report.

- Buffer Overflow: Includes the BufOvfls in the report. The parameter BufOvfl indicates to the client that entries within the buffer may have been lost.
- Entry ID: Includes EntryID in the report.
- Configuration Revision: Includes the ConfRev in the report. The attribute ConfRevshall represent a count of the number of times that the configuration of the data-setreferenced by DatSethas been changed.

---

### 9.5.5 FAST GOOSE

The FastGOOSE of MU320E is a feature that utilizes the hardware technology of FPGA to implement the subscribing and publishing of the GOOSE messages, which allows reading and sending times lower than 100 $\mu$ s. All the 32 GOOSE inputs and one preset Goose Publisher (supporting only binary inputs) uses this feature.

---

## 9.6 Logic Settings

MU320E has a powerful and intuitive IEC 61113-3 based logic tab that allows the user to apply the device as the interface between physical and digital worlds, digitizing primary equipment in the yard, considering:

- GOOSE and Binary Inputs being associated to the following configurable logical nodes in data model:
  - XCBR – For circuit breakers monitoring and control;
  - XSWI – For switchgears monitoring and control;
  - SIMG – For gas insulation monitoring;
  - SIML – For oil insulation monitoring;
- Configurable logical nodes being associated to Binary Outputs;
- GOOSE and Binary Inputs being directly associated to Binary Outputs;

All logical nodes above mentioned represents a digital model that follows the implementation described by the IEC61850-7-4 and further specification described in the MICS (Model Implementation Conformance Statement) related to the MU320E version. The configurable parameters are described below:

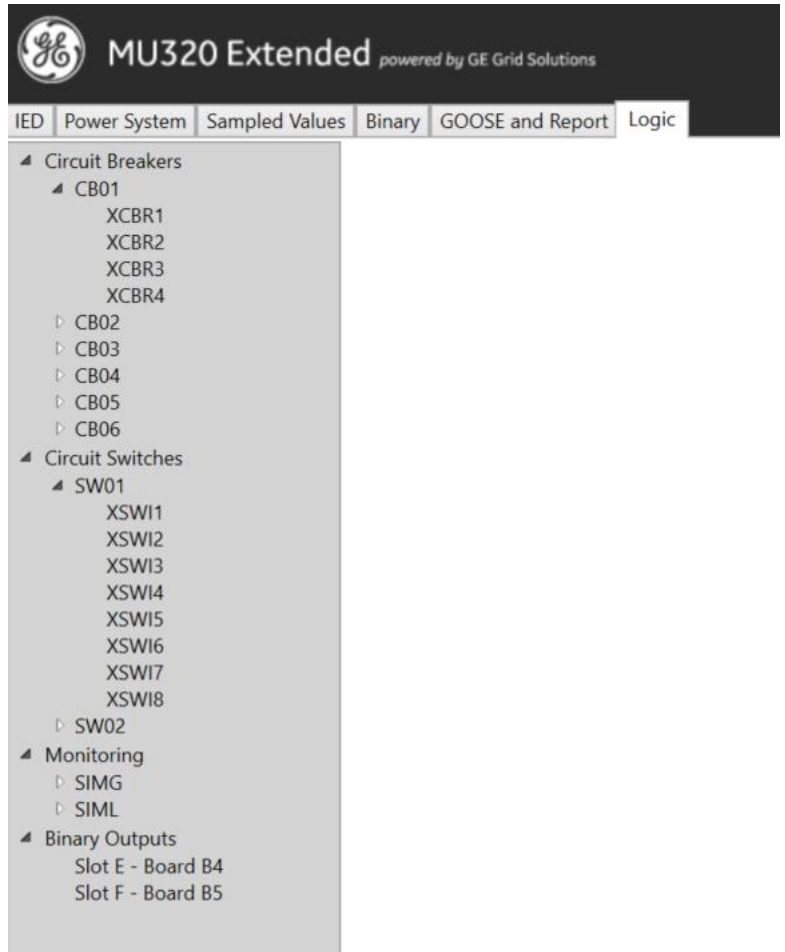

Logic Configuration Main Screen

TREE	ITEM	DESCRIPTION
Circuit Breakers	CB01 .. CB06	Configuration for 6 sets of Circuit Breakers with 4 <i>XCBR</i> instances for each set
Circuit Switches	SW01 and SW02	Configuration for 2 sets of circuit switches with 8 <i>XSWI</i> instances for each set
Monitoring	SIMG	Configuration for 18 <i>SIMG</i> instances
	SIML	Configuration for 18 <i>SIML</i> instances
Binary Outputs	CORTEC dependent	Configuration for all Binary Output, available in the CORTEC, organized in groups per Slot

## 9.6.1 INPUTS TO DATA MODEL

All GOOSE and Binary Inputs can be associated to the configurable Logical Nodes (*XCBR*, *XSWI*, *SIMG* and *SIML*) in data model in a similar way, considering the interface shown in the figure below and its features:

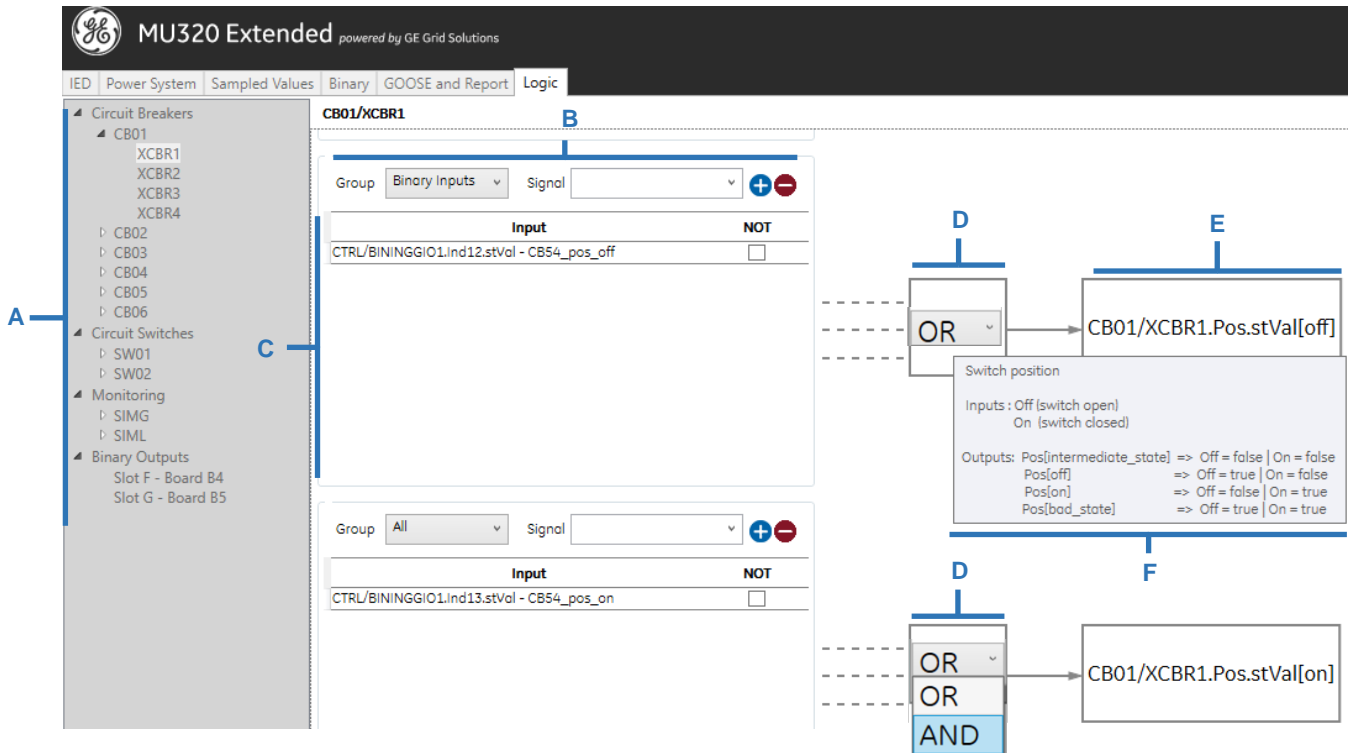

Binary Inputs to Data Model configuration reference

**A Selection Tree:** Allows the user to navigate in the tree to choose what instance of which logical node to configure.

**B Input Selection:** Section to select the input signal to be added to the list of inputs in the logic allowing to select:

- **Group:** That filters the input type according to the options:
  - **Binary Inputs**
  - **GOOSE Inputs**
  - **XCBR:** Any non-control Boolean available in one of the *XCBR* instances in data model.
  - **XSWi:** Any non-control Boolean available in one of the *XSWI* instances in data model.
  - **SIMG:** Any Boolean available in one of the *XSWI* instances in data model.
  - **SIML:** Any Boolean available in one of the *XSWI* instances in data model.
  - **Control:** Any control Boolean available in one of the *XSWI* or *XCBR* instances in data model.
  - **All**
- **Signal:** Effectively select the signal to be added to the list of inputs.

**C Input list:** It holds the list of all inputs selected to perform the logic block. In this list it is possible to select which, if any, signals will have inverse values to the logic block by checking the **NOT** checkbox.

**D Logic Block:** It shows the logic operation that will be executed with the signals in the input list to calculate the value to the configured data attribute. It is possible to select **OR** operation or **AND** operation.

**E Data Attribute:** It shows the IEC61850 naming to the data attribute that will receive the result of the configured logic operation.

**F Tooltip:** This tooltip is shown after left the mouse cursor over the data attribute and helps the user to understand what the meaning of the data attribute in the application context.

**Note:** Double point Data Attributes needs to have both Boolean status configured for correct modeling and behavior.

*E.g: For correct representation of `XCBR.pos.stVal` it is necessary to configure `XCBR.pos.stVal[on]` and `XCBR.pos.stVal[off]`.*

It is important to note that due to the IEC61850-7-4 modeling and the behavior of the physical equipment being represented by the Data Model some Data Attributes in *XCBR* and *XSWI* have more complex logics to determine its value. All logic is represented to the user through the diagrams as the example below.

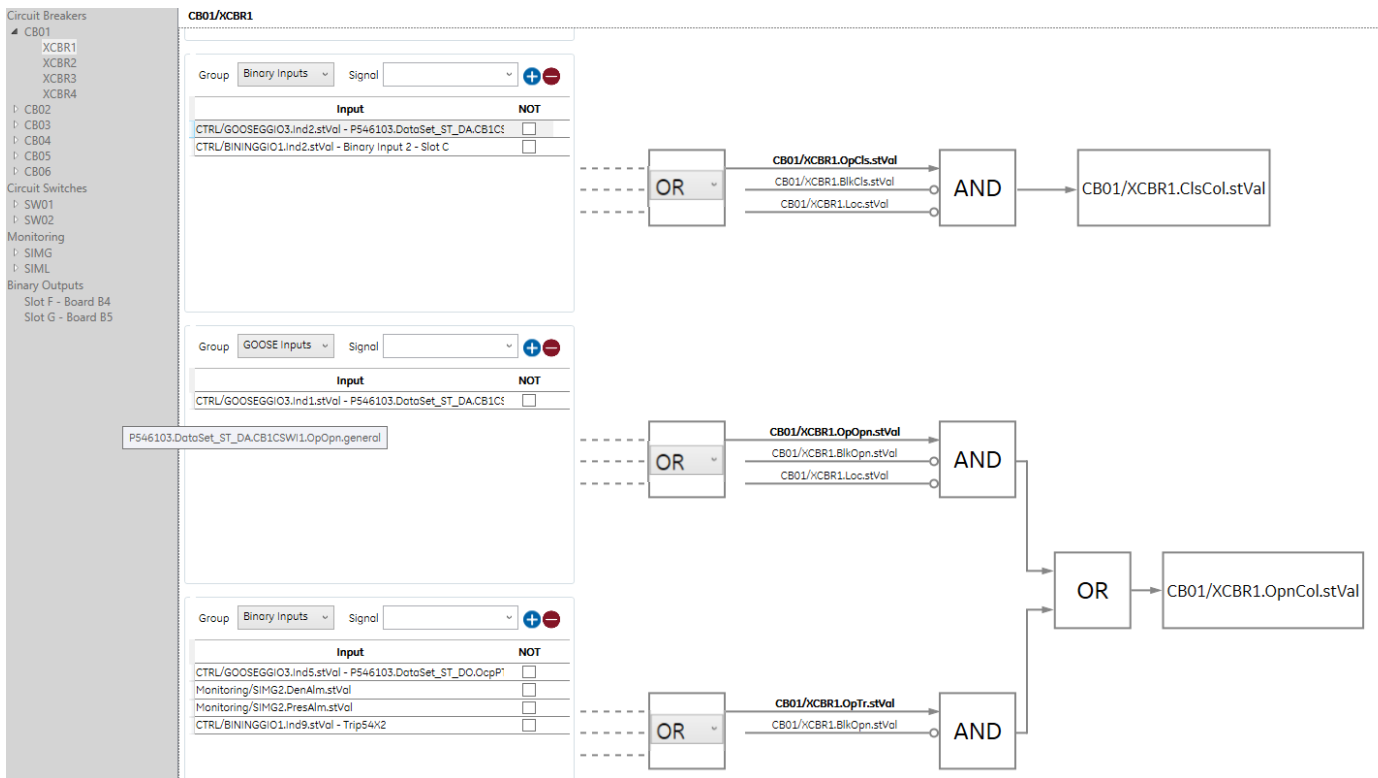

Binary Inputs to Data Model for logics with more than one element

For Circuit Switches (*XSWI*) and Circuit Breakers (*XCBR*) the Data Attribute that represents the blocking of opening or closing signals can be associated with a latching behavior with reset available through GOOSE or Binary Input, as exemplifies the diagram below.

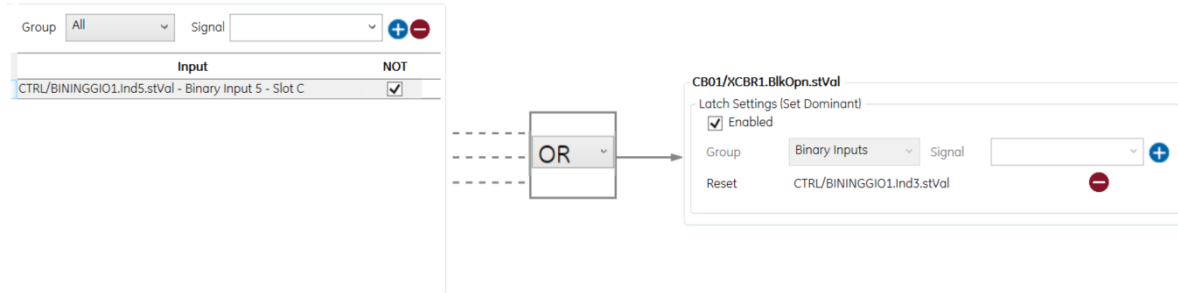

Circuit Breaker Opening Block by latching logic

## 9.6.2 INPUTS OR DATA MODEL TO BINARY OUTPUTS

All GOOSE and Binary Inputs can be associated to the configurable Logical Nodes (*XCBR*, *XSWI*, *SIMG* and *SIML*) in data model in a similar way, considering the interface shown in the figure below and its features:

**MU320 Extended** powered by GE Grid Solutions

Navigation: IED | Power System | Sampled Values | Binary | GOOSE and Report | Logic

**Tree View (A):**

- Circuit Breakers
  - CB01
    - XCBR1
    - XCBR2
    - XCBR3
    - XCBR4
  - CB02
  - CB03
  - CB04
  - CB05
  - CB06
- Circuit Switches
- Monitoring
- Binary Outputs
  - Slot E - Board B4
  - Slot F - Board B5

**Logic Configuration (B):**

Slot F - Board B5

Output operates a circuit breaker or switch

Group: XCBR | Signal: [Dropdown]

Input	NOT
CB01/XCBR1.BlkOpn.stVal	<input type="checkbox"/>

Output operates a circuit breaker or switch

Group: Control | Signal: [Dropdown]

Input	NOT
CB01/XCBR1.OpnCol.stVal	<input type="checkbox"/>

**Output Settings (C):**

CTRL/CMDOUTGGIO2.Ind52.stVal - Binary Output 4 - Slot F

Mode: Latch

Timer Setting: Pick Up Timer [ ] ms, Drop Off Timer [ ] ms

Latch Settings (Set Dominant): Group: Binary Inputs, Signal: [Dropdown], Reset: CTRL/BININGGIO1.Ind4.stVal

CTRL/CMDOUTGGIO2.Ind53.stVal - Binary Output 5 - Slot F

Mode: Drop Off

Timer Setting: Pick Up Timer [ ] ms, Drop Off Timer: 1000 ms

Latch Settings (Set Dominant): Group: All, Signal: [Dropdown], Reset: [ ]

Buttons: Cancel, Ok

Output Configuration Screen

**A Selection Tree:** Allows the user to navigate in the tree to choose what instance of which logical node to configure.

**B Input Selection:** Section to select the input signal to be added to the list of inputs in the logic allowing to select:

- **Group:** That filters the input type according to the options:
  - **Binary Inputs**
  - **GOOSE Inputs**
  - **XCBR:** Any non-control Boolean available in one of the *XCBR* instances in data model.
  - **XSWI:** Any non-control Boolean available in one of the *XSWI* instances in data model.
  - **SIMG:** Any Boolean available in one of the *XSWI* instances in data model.
  - **SIML:** Any Boolean available in one of the *XSWI* instances in data model.
  - **Control:** Any control Boolean available in one of the *XSWI* or *XCBR* instances in data model.
  - **All**
- **Output operates a Circuit Breaker or Switch:** If this option is enabled it forbids any type of input to be selected if it is not in the Control group.
- **Signal:** Effectively select the signal to be added to the list of inputs.

**C Input list:** It holds the list of all inputs selected to perform the logic block. In this list it is possible to select which, if any, signals will have inverse values to the logic block by checking the **NOT** checkbox.

**D Logic Block:** It shows the logic operation that will be executed with the signals in the input list to calculate the value to the configured Binary Output. It is possible to select **OR** operation or **AND** operation.

**E Output Activation mode:** Selects the Binary Output behavior considering:

- **Pickup:** When an input signal goes high the timer waits for a time indicated by the Pickup Time before driving the output high. If the input drops off while the pickup timer is in the process of expiring, the timer immediately resets holding the output low.
- **Dropoff:** When the input signal goes high the timer output will be driven high. When the input drops off the timer waits for the time indicated by the Dropoff Time before driving the output low. If the input picks up again while the timer is in the process of expiring the timer immediately resets and continues to timeout holding the output high. (opposite of the pickup timer).
- **Pickup/Dropoff:** This mode combines the functionality of both timers to produce delays on both pick up and drop off.
- **Pulse:** When the input signal goes high the pulse timer immediately drives the output high for the duration of the pulse setting time, irresponsive to input status once the pulse started. After this period expires the output is driven low.
- **Straight-through:** This the output without any conditioning. When input goes high, the output goes high. When the input goes low, the output goes low.
- **Latching (Set dominant):** Works like a flip flop where after the input sets the output, it is held on high state until another input resets this state.

**F Pickup/Dropoff time:** Pickup and/or Dropoff times for these output modes configuration.

**G Resetting signal:** Section to select the input that will reset the output after it has been set. Only available for latching output mode.

**H Output type indicator:** Graphical way to inform user what type of output it is: Form-A or Form-C.



**Note:**

- 1- The Logic has a maximum processing time of 1ms that can vary depending on the configuration.
- 2- The maximum total time for a binary output to be activated is the sum of the logic processing time and the operation time of each binary output.

## 9.7 Upgrade Settings

It is possible to upgrade configuration for MU320 hardware version E to match the possible configurations for the current firmware version.

This process is done automatically during firmware upgrade or can be performed offline through the ICT as shown in the figure below.

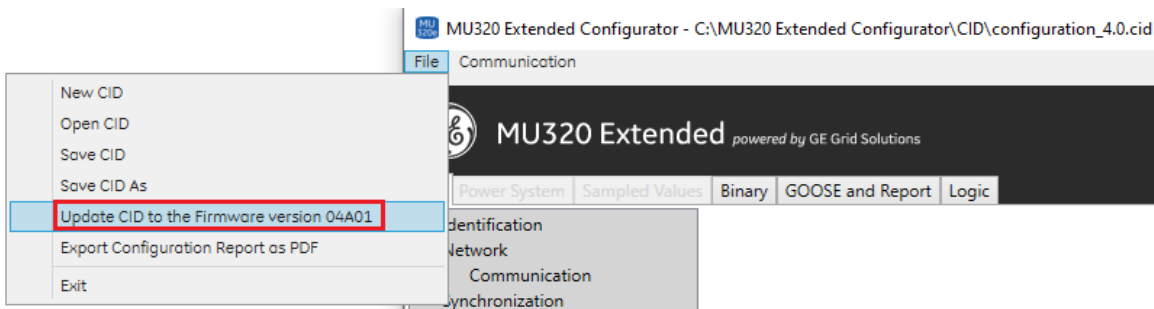

Option to upgrade CID configuration



**Note:**

There is no automatic process to upgrade configurations from MU320 Hardware A or firmware version lower than 04A00.

## 9.8 Access Control CLI

To allow integration of MU320E with third-party password management tools it is possible to use the Access Control CLI available at *<MU320E Extended Configurator folder>/CLI/AccessControl.exe*.

Commands can be executed through CLI in the following format:

```
AccessControl.exe -action <action> -user1 <user1> -pass1 <pass1> -ip <ip> -user2 <user2> -pass2 <pass2>
```

There are two actions accessible through this CLI:

- **Password Validation:** Validates a given password to a certain MU320E with the command. The command returns a string composed by a code and a message confirming if the password is valid. It requires the following parameters:
  - **<action>**: Fixed action **validatePassword**
  - **<user1>**: The username which password will be validated
  - **<pass1>**: The user's password to be validated
  - **<ip>**: The device's IP address

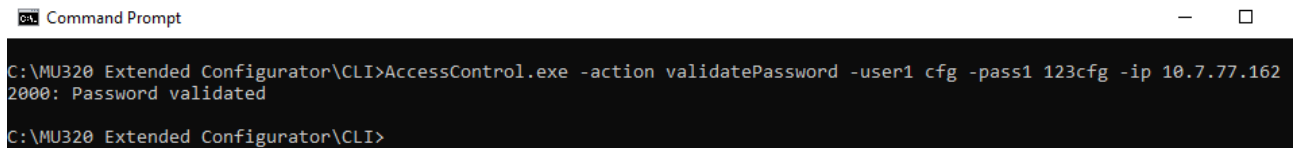

```
Command Prompt
C:\MU320 Extended Configurator\CLI>AccessControl.exe -action validatePassword -user1 cfg -pass1 123cfg -ip 10.7.77.162
2000: Password validated
C:\MU320 Extended Configurator\CLI>
```

*Example of a validatePassword action*

- **Change Password:** Changes password for certain user in a MU320E. The command returns a string composed by a code and a message confirming if the password was changed. It requires the following parameters:
  - **<action>**: Fixed action **changePassword**
  - **<user1>**: The controller user used to change the password of **<user2>**. **<user1>** must have authority to perform this action, similar to what would be done through administration screen.
  - **<pass1>**: The controller user's password to be authenticated by the device
  - **<ip>**: The device's IP address
  - **<user2>**: The controlled user which password will be changed
  - **<pass2>**: The new controlled user's password

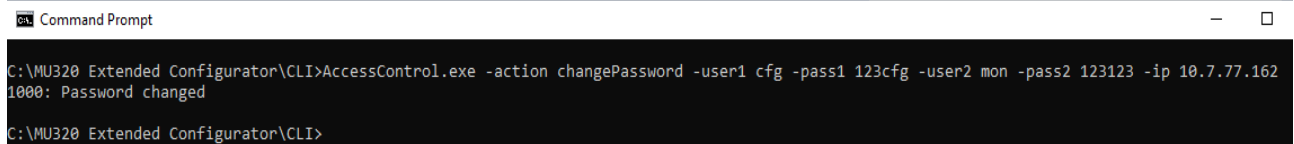

```
Command Prompt
C:\MU320 Extended Configurator\CLI>AccessControl.exe -action changePassword -user1 cfg -pass1 123cfg -user2 mon -pass2 123123 -ip 10.7.77.162
1000: Password changed
C:\MU320 Extended Configurator\CLI>
```

*Example of a changePassword action*

# MU320E

## Integrated Merging Unit

### Chapter 5: Operation

The MU320E has an application software called Merging Unit Configurator, that downloads equipment Log files, and a local interface with important status indicators. Log file is used to verify the equipment system events.

This chapter describes the local and remote interfaces of the equipment.

For information about software installation, refer to Chapter 7: Installation.

---

#### 1 Local Interface

MU320E local interface is comprised of six status indicators, as shown in below figure.

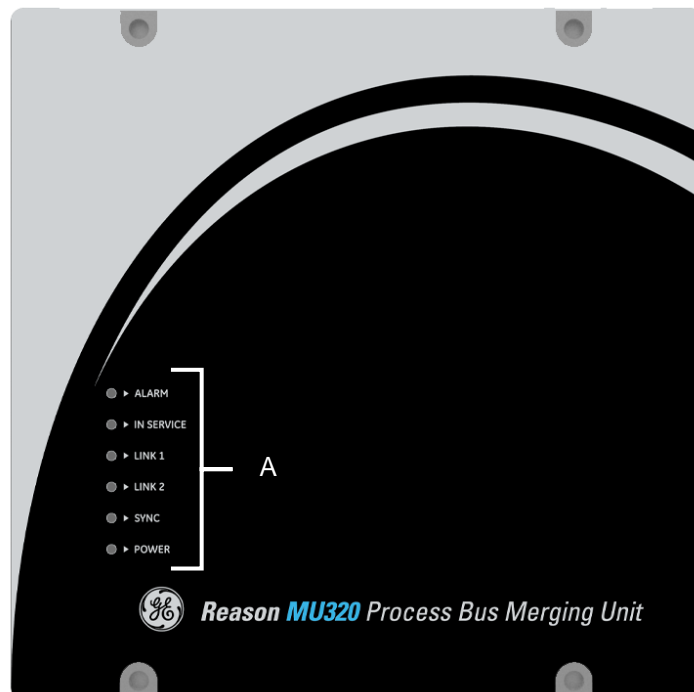

*MU320E local interface*

**A** Equipment status indicators:

- The ALARM indicator should light up for a brief period while the unit is being initialized. After concluding the initialization, the unit will start operating and this indicator should turn off. In case the ALARM indicator remains on, the unit will not be in operation and operator assistance will be necessary.
- The IN SERVICE indicator lights up when the equipment is operating normally and has already been configured. When the IN SERVICE indicator lights up on the front panel, the signaling contact IN SERVICE on the rear panel of the equipment will be open.
- The LINK 1 and LINK 2 indicators light up when the Ethernet 1 and Ethernet 2 ports are properly connected to the network and are active, respectively.
- The SYNC indicator lights up when the equipment is synchronized with time source that has reference from GPS satellites. This indicator blinks when the equipment is synchronized with time source that has missed the reference from GPS satellites.
- The POWER indicator lights up when the power supply is connected to the equipment.



*Note:*  
*The MU320E will not come into operation mode, and will not lights up IN SERVICE indicator, before the first configuration*

---

## 2 Remote Interface

### 2.1 HMI Screen

The HMI screen, in the figure below, allows the user with **MON** credentials to access <Status>, <General Information> and <Logs> from the connected MU320E.

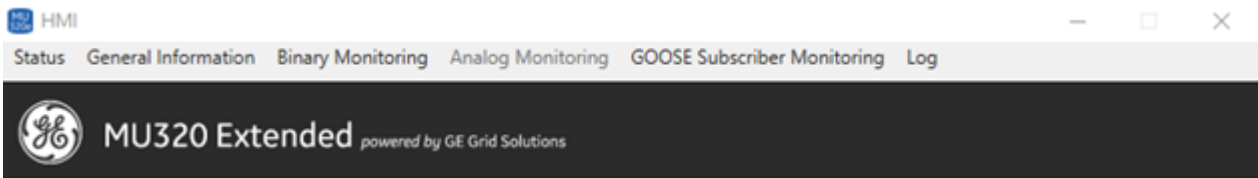

*HMI main Screen*

---

#### 2.1.1 STATUS SCREEN

The Status Screen, in the figure below, shows the main information and status related to the device, including:

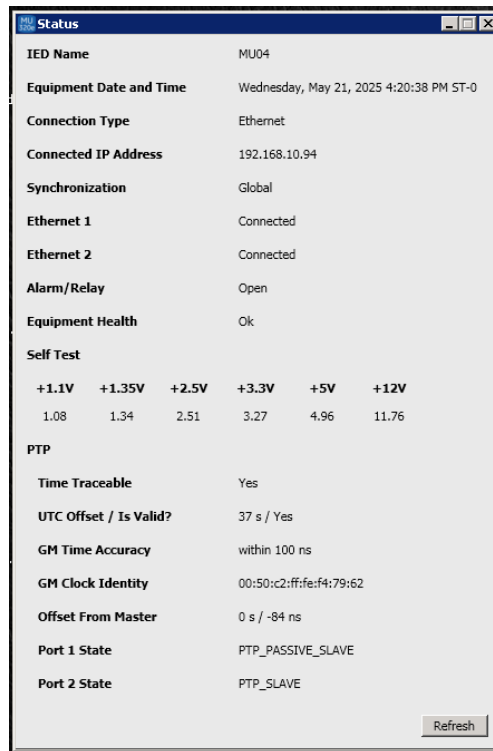

Status Screen

- **IED name.**
- **Equipment Data and Time.**
- **Connection Type:** Ethernet/Serial.
- **Connected IP Address.**
- **Synchronization:** OK/NOK.
- **Ethernet (1,2):** Connected/Disconnected.
- **Alarm/Relay:** Open/Closed.
- **Equipment Healthy:** Ok/Warning/Alarm.
- **Self Test:** for all internal voltages **+1.1V, +1.35V, +2.5V, +3.3V, +5V, +12V.**
- **PTP synchronization info:**
  - **Time traceable:** Yes/No.
  - **UTC offset.**
  - **Grand Master Time Accuracy.**
  - **Grand Master Clock Id.**
  - **Offset from master.**
  - **Port (1/2) state.**

The screen is updated each 30s, if you need faster update you can use the <Refresh> button.

If the MU320E is configured to be synchronized through IRIG-B or it is not synchronized PTP synchronization info will not be displayed.

## 2.1.2 GENERAL INFORMATION SCREEN

The General Information Screen, in the figure below, shows more detailed information related to the device, including:



General Information Screen

- **IED name.**
- **CORTEC.**
- **Firmware Version.**
- **Serial Number.**
- **Network Information (1,2):** IP Address, Network Mask, Gateway address and MAC Address. If configured for PRP only one network information is shown.
- **Modules Information:** Module identifier, Board name, Serial Number, Board version.

### 2.1.3 ANALOG MONITORING SCREEN

The Analog Monitoring Screen, in the figure below, shows the main information about the status of MU320E analog acquisition.

Data is updated at each 5 seconds for all installed analog acquisition module, each module is identified by the Order code name in the slot position.

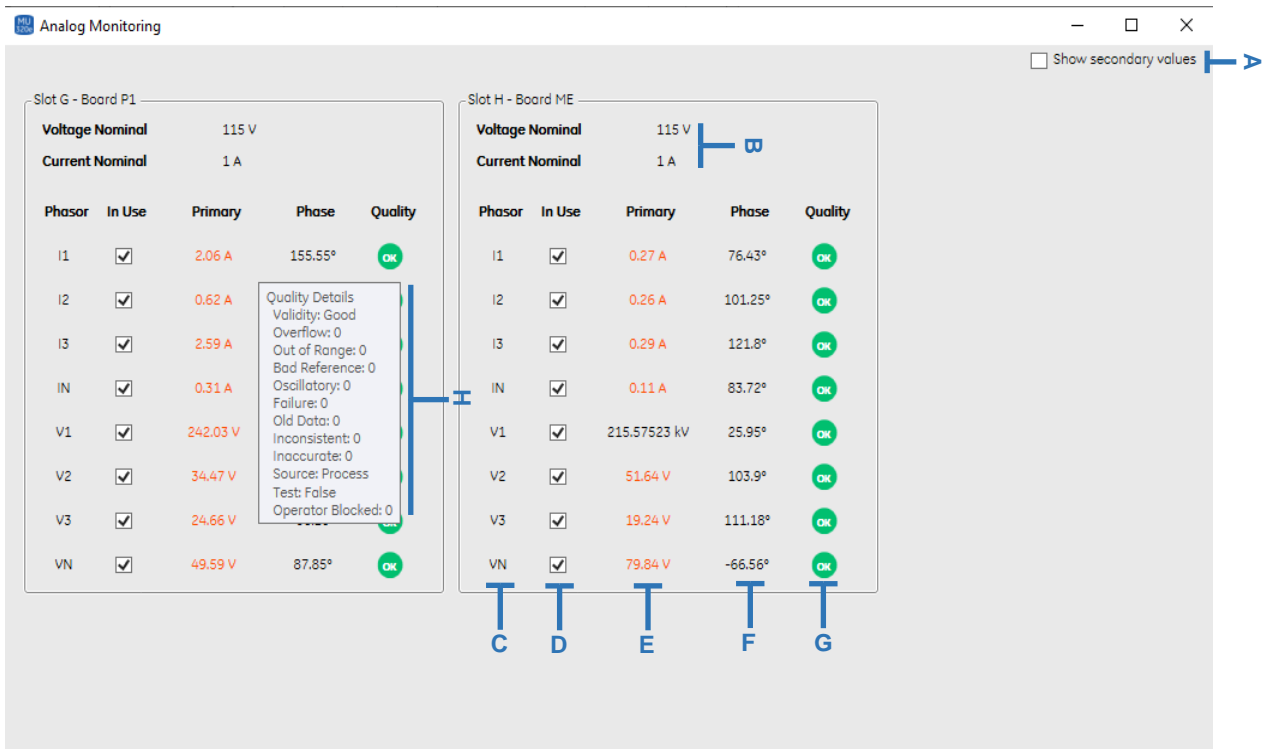

Analog Monitoring Screen

The main sections in the screen are:

- **A:** Optionally data can be displayed also in secondary values by enabling this checkbox.
- **B:** Fixed informative field with nominal values of voltage and current.
- **C:** Identifier correspondent to the channel measured in each analog acquisition module. The prefixes **I** and **V** identify current and voltage, respectively.
- **D:** Marks if the channel is “in use” by the application. If the channel is not marked as “in use” the fields related to that channel will be grayed-out.
- **E:** Shows the measured value for the channel (voltage or current).
  - Magnitude of phasor values are displayed in primary or secondary values, depending on what is selected in **A**.
  - If the channel is marked as “in use” and the measured value is **below 5% of the nominal value**, it will be displayed in orange as represented in the picture above.
- **F:** Shows the measured angle for the channel.
- **G:** Shows the quality for that channel.
  - If validity is Valid, then the indicator is green (Ok)
  - If validity is Questionable or invalid, then the indicator is orange (?)
- **H:** This is a tooltip that is shown when the mouse hovers the quality indicator, expanding the quality details for that channel with info for the fields:
  - **Validity**
  - **Overflow**
  - **Out of Range**
  - **Bad Reference**
  - **Failure**
  - **Old Data**

- **Inconsistent**
- **Inaccurate**
- **Source**
- **Test**
- **Operator Blocked**

## 2.1.4 BINARY INPUTS MONITORING SCREEN

The Binary Inputs Monitoring Screen, in the figure below, shows the main information about the status of MU320E binary inputs acquisition.

All installed modules with binary inputs are presented and data is updated at each 5 seconds.

Binary input channels are grouped considering the slot position and the board type, identifiable by the Order code.

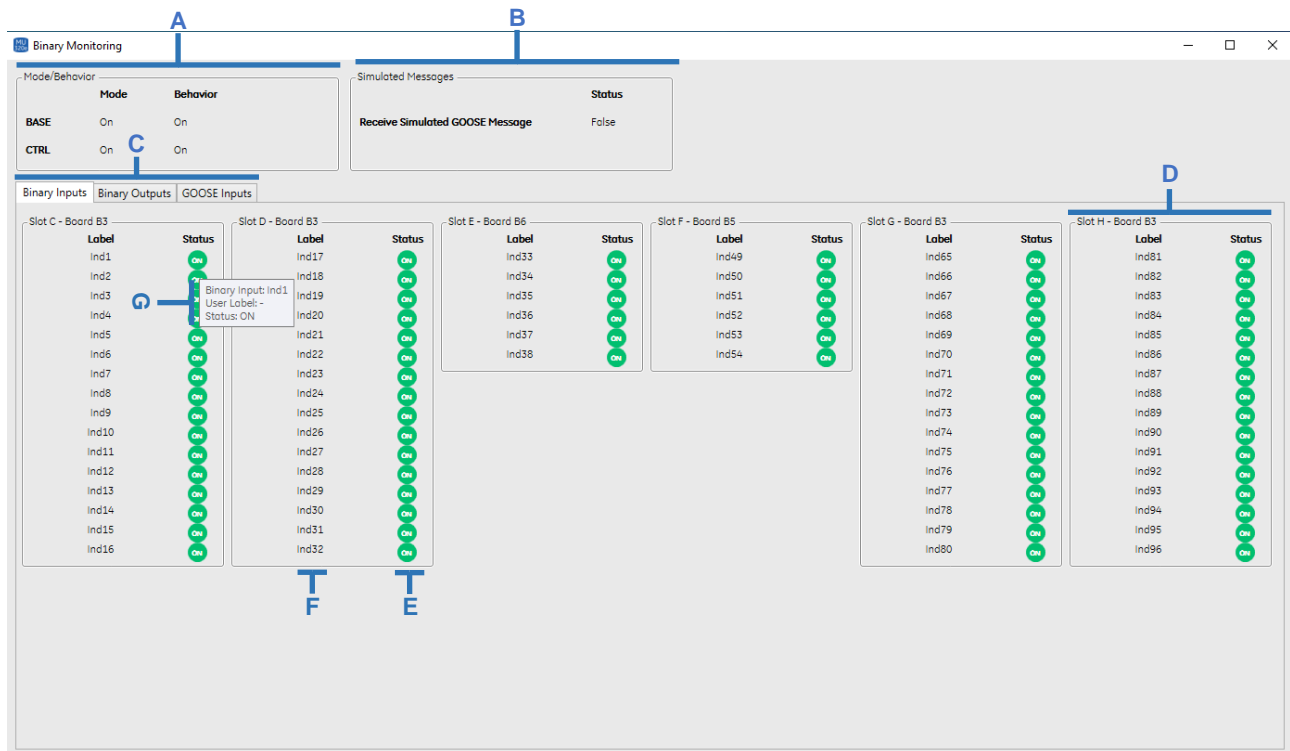

Binary Inputs Monitoring Screen

The main sections in the screen are:

- **A:** Mode/Behavior indicator for the main Logical Devices **BASE** and **CTRL**
- **B:** Field to identify if the MU320E is accepting receive simulated GOOSE messages or not
- **C:** Selector tab to navigate in between binary inputs, binary outputs or GOOSE inputs monitoring Screen
- **D:** Group of digital inputs organized by slot/board
- **E:** Binary Input channel status:
  - **ON:** Indicator in Green
  - **OFF:** Indicator in Gray
- **F:** Label of the binary channel.

- **G:** Tooltip with main information about the binary channel shown when mouse hovers the status of the channel

## 2.1.5 BINARY OUTPUT MONITORING SCREEN

The Binary Output Monitoring Screen, in the figure below, shows the main information about the status of MU320E binary outputs.

All installed modules with binary outputs are presented and data is updated at each 5 seconds.

Binary outputs are grouped considering the slot position and the board type, identifiable by the Order code.

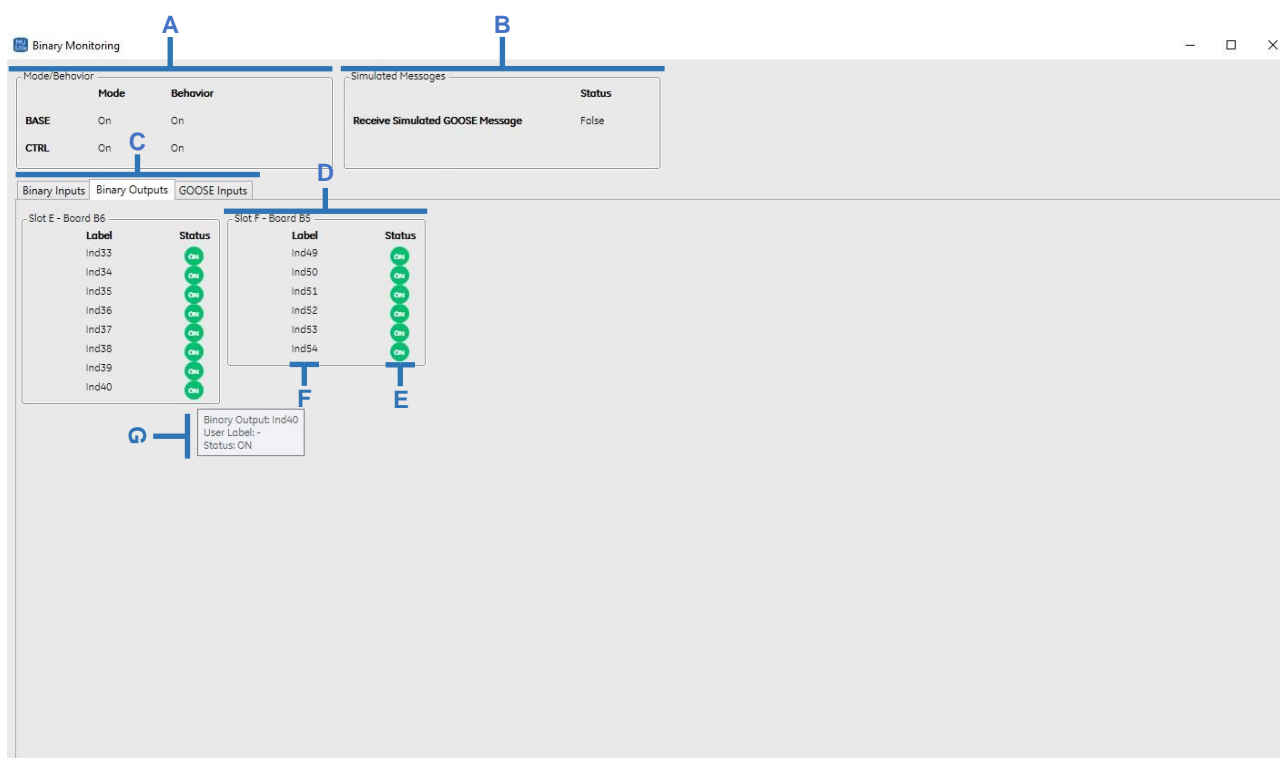

*Binary Output Monitoring Screen*

The main sections in the screen are:

- **A:** Mode/Behavior indicator for the main Logical Devices **BASE** and **CTRL**
- **B:** Field to identify if the MU320E is accepting receive simulated GOOSE messages or not
- **C:** Selector tab to navigate in between binary inputs, binary outputs or GOOSE inputs monitoring Screen
- **D:** Group of digital outputs organized by slot/board
- **E:** Binary output channel status:
  - **ON:** Indicator in Green
  - **OFF:** Indicator in Gray
- **F:** Label of the binary output
- **G:** Tooltip with main information about the binary channel shown when mouse hovers the status of the output

## 2.1.6 GOOSE INPUT MONITORING SCREEN

The GOOSE Input Monitoring Screen, in the figure below, shows the main information about the status of GOOSE inputs subscribed by MU320E.

All installed modules with binary outputs are presented and data is updated at each 5 seconds.



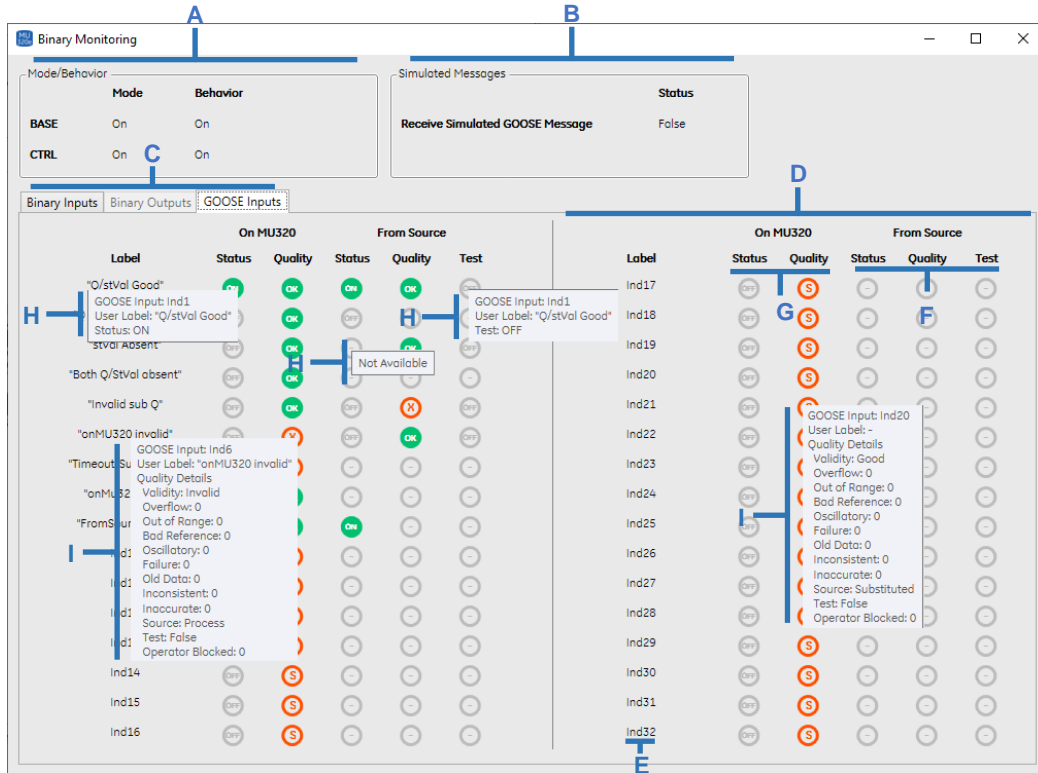







Binary outputs are grouped considering the slot position and the board type, identifiable by the Order code.



GOOSE Input Monitoring Screen

The main sections in the screen are:

- **A:** Mode/Behavior indicator for the main Logical Devices **BASE** and **CTRL**
- **B:** Field to identify if the MU320E is accepting receive simulated GOOSE messages or not
- **C:** Selector tab to navigate in between binary inputs, binary outputs or GOOSE inputs monitoring Screen
- **D:** Grouping of 16 GOOSE inputs. MU320E has 2 groups, totaling 32 GOOSE inputs
- **E:** Label of the GOOSE input, defined by MU320E configuration
- **F:** Information about incoming GOOSE messages **from source**:
  - **Status:**
    - **ON:** Indicator in Green (On)
    - **OFF:** Indicator in Gray (Off)
  - **Quality:**
    - **GOOD:** Indicator in Green (Ok)
    - **INVALID:** Indicator in Orange (X)
    - **QUESTIONABLE:** Indicator in Orange (?)

- **Not Available:** Indicator in Gray (-) 
  - **Test:**
    - **ON:** Indicator in Green (On) 
    - **OFF:** Indicator in Gray (Off) 
    - **Not Available:** Indicator in Gray (-) 
- **G:** Information about the interpreted GOOSE messages on **MU320E:**
  - **Status:**
    - **ON:** Indicator in Green (On) 
    - **OFF:** Indicator in Gray (Off) 
  - **Quality:**
    - **GOOD:** Indicator in Green (Ok) 
    - **INVALID:** Indicator in Orange (X) 
    - **QUESTIONABLE:** Indicator in Orange (?) 
    - **Subscription error:** Can happen if the subscription is not configured, is invalid, mismatch test mode or GOOSE has timeout. The indicator is an Orange (S)  marking that GOOSE input with the Substituted flag and assigning the value defined by the configuration described in 9.5.2
- **H:** Tooltip with main information about the status of the GOOSE input shown when mouse hovers the property status from source or on MU320E
- **I:** Tooltip with main information about the status of the GOOSE quality shown when mouse hovers the property status from source or on MU320E. The tooltip shows the following fields:
  - **Validity**
  - **Overflow**
  - **Out of Range**
  - **Bad Reference**
  - **Oscillatory**
  - **Failure**
  - **Old Data**
  - **Inconsistent**
  - **Inaccurate**
  - **Source**
  - **Test**
  - **Operator Blocked**

## 2.1.7 GOOSE SUBSCRIBER MONITORING SCREEN

The GOOSE Subscriber Monitoring Screen, in the figure below, shows the list of Subscribed GOOSE control blocks by MU320E and its main information. Data is updated at each 30 seconds.

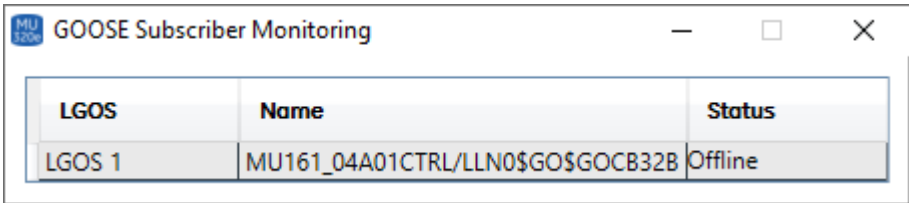

LGOS	Name	Status
LGOS 1	MU161_04A01CTRL/LLN0\$GO\$GOCB32B	Offline

GOOSE Subscriber Monitoring Screen

Information monitored are:

- **LGOS** instance.
- **Name** of the subscribed control block at that LGOS instance.
- **Status** of that control block subscription.

## 2.2 Log SCREEN

The Log Screen, in the figure below, shows the list of logs registered by the device and this list can be filtered by *Period*, *Code* and *class*. All logs can be downloaded using the button *<Download>*.

It is possible to searches specific logs or time intervals. For example, search a log between L300 and L399, just enter L3??, and to search a list, enter L2??, L507, L700. Code shall be entered with 3 digits.

The main information in the list of logs are:

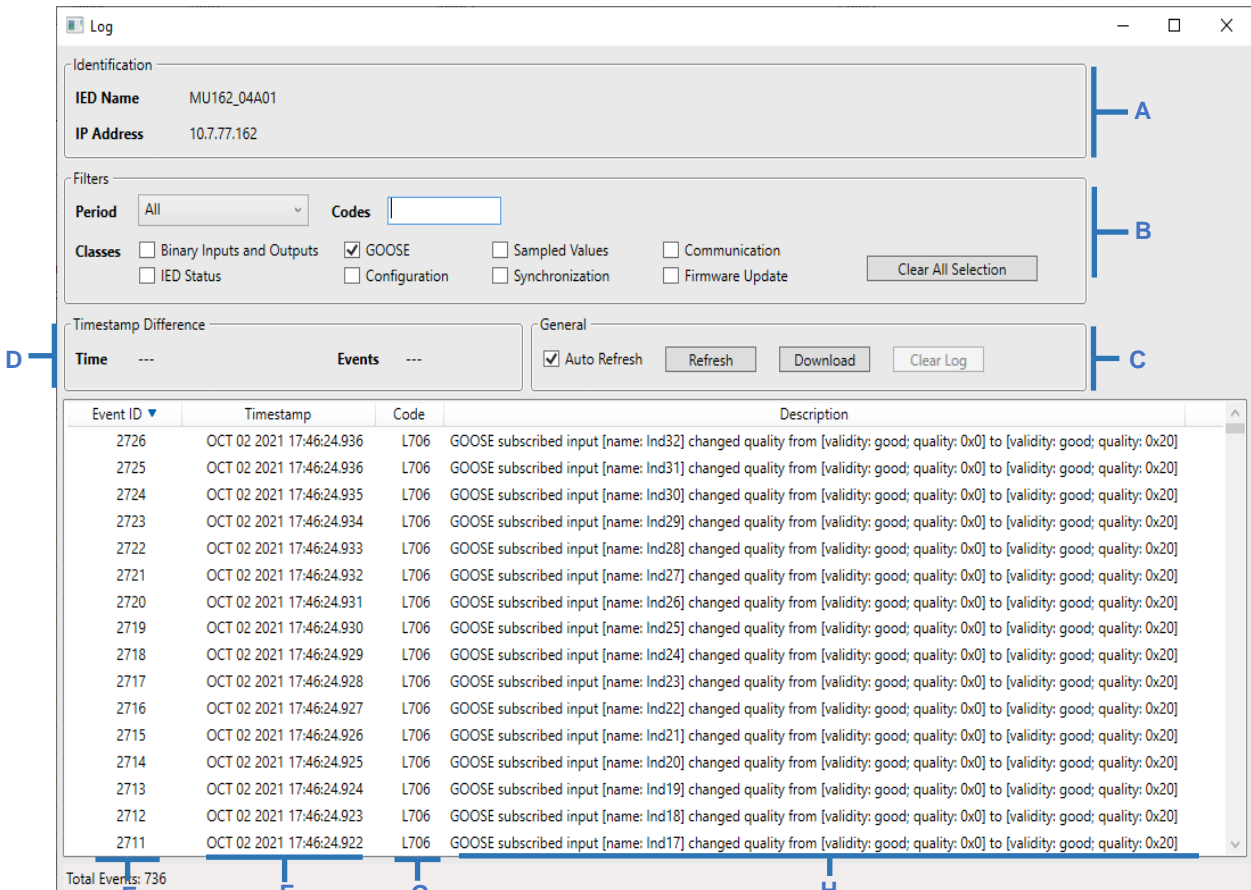

Log Information Screen

- **A:** Identification of the IED with the name and IP Address.
- **B:** Filters allowing to show only the filtered events. Filters can be applied by *period*, *code* or *Classes*.
- **C:** Field group to general actions on the logs:

- **Auto Refresh:** Enable or disable the screen Auto Refresh.
- **Refresh:** Button to force refresh. Especially useful when Auto Refresh is disabled.
- **Download:** Button to download log in **.txt** format.
- **Clear log:** Button to clear device’s logs. This button is enabled only for ADM user.
- **D:** Field group to support log event analysis, allowing to determine timestamp differences lower than one hour in between two selected events in the table of logs. This feature is available only if **Auto Refresh is disabled**.

Event ID	Timestamp	Code	Description
2734	OCT 04 2021 22:46:39.363	L500	Procedure to receive configuration: [ok]
2733	OCT 04 2021 22:30:52.187	L500	Procedure to receive configuration: [ok]
2732	OCT 04 2021 10:45:25.642	L500	Procedure to receive configuration: [ok]
2731	OCT 02 2021 17:47:42.136	L101	PhyHealth: [ok; cause: Instrument reestablished]
2730	OCT 02 2021 17:47:42.000	L400	Time synch: [kind: global; grandmaster: c4b512ffe00010b; source: PTP]
2729	OCT 02 2021 17:47:25.002	L200	Ethernet link: [interface: 2; status: on]
2728	OCT 02 2021 17:47:25.001	L200	Ethernet link: [interface: 1; status: on]
2727	OCT 02 2021 17:46:24.937	L702	Binary output changed its value: [index: 17; status: on; name: _d_1]
2726	OCT 02 2021 17:46:24.936	L706	GOOSE subscribed input [name: Ind32] changed quality from [validity: good; quality: 0x0] to [validity: goo
2725	OCT 02 2021 17:46:24.936	L706	GOOSE subscribed input [name: Ind31] changed quality from [validity: good; quality: 0x0] to [validity: goo
2724	OCT 02 2021 17:46:24.935	L706	GOOSE subscribed input [name: Ind30] changed quality from [validity: good; quality: 0x0] to [validity: goo
2723	OCT 02 2021 17:46:24.934	L706	GOOSE subscribed input [name: Ind29] changed quality from [validity: good; quality: 0x0] to [validity: goo
2722	OCT 02 2021 17:46:24.933	L706	GOOSE subscribed input [name: Ind28] changed quality from [validity: good; quality: 0x0] to [validity: goo
2721	OCT 02 2021 17:46:24.932	L706	GOOSE subscribed input [name: Ind27] changed quality from [validity: good; quality: 0x0] to [validity: goo
2720	OCT 02 2021 17:46:24.931	L706	GOOSE subscribed input [name: Ind26] changed quality from [validity: good; quality: 0x0] to [validity: goo

Example for analysis of Log events

- **E:** ID for each log event. By clicking in the header of the table it is possible to sort events by ID in ascending or descending order. Event ID is also shown In timestamp Difference analysis.
- **F:** Timestamp of the event displayed in the format “*MON DD YYYY HH:MM:SS.FractionOfSecond*”.
- **G:** Log code of the event.
- **H:** Description of the event.

The list of possible log codes and description can be seen in Appendix B.

## 2.3 Administrative tools SCREEN

The Administrative Tools Screen, shown in the figure below, allows the user to administrate a MU320E device considering:

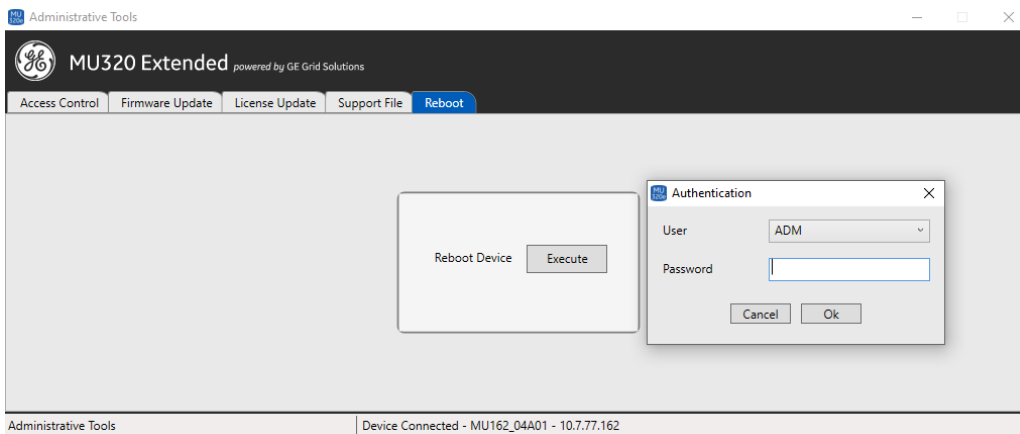

Administrative Tools Screen

- **Access Control:** Tab to change the password for all available users.
- **Firmware update:** Tab to upload the firmware file and run the firmware update.
- **License update:** Tab to upload the license file and run the license update.
- **Support File:** Tab to download the support files.
- **Reboot:** Tab to remotely execute reboot command in MU320E (requires authentication).

## 3 Measurement Behavior

When the analogue values measured by the MU320E exceeds the dynamic range, *i.e.* when the readings are greater than  $40 \times I_n$ , the MU320E will assert a quality bit within the SV frame known as **outOfRange**, described in the IEC 61850-7-3 ed.2. The purpose of this bit is to flag to the IEDs in the Process Bus that the data sent by the MU320E does not represent the actual physical quantity, since the analogue signal exceeded the dynamic range of the device and, thus, the measurement is out of range.

During the period of time that the MU320E is out of range, the value sent by the device will be the maximum value of the dynamic range ( $40 \times I_n$ ). The figures below exemplify it. The top figure is the actual signal and the bottom figure is the measure sent with the **outOfRange** bit asserted.

When **outOfRange** is true, quality is set to questionable.

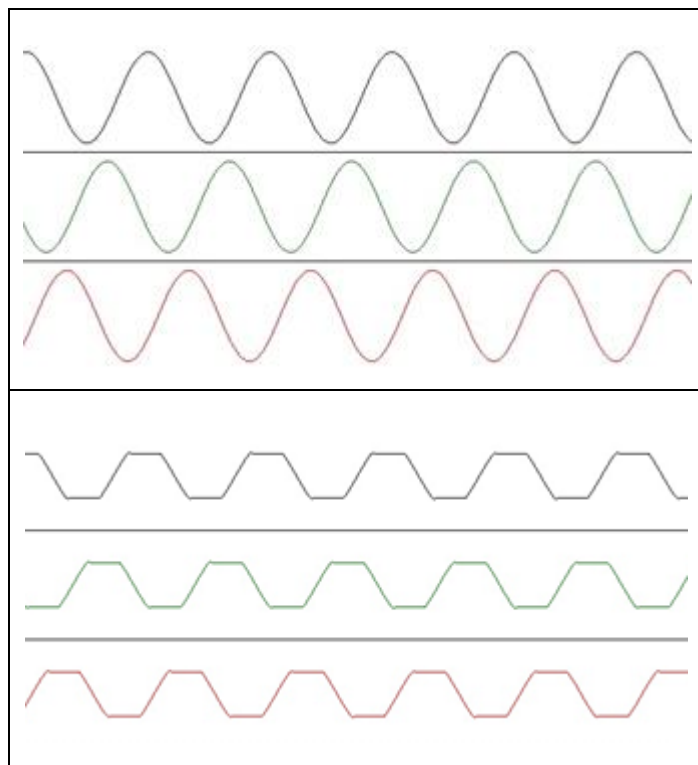

Values when MU320E is with outOfRange bit asserted

## 4 Holdover, Free Running and Resynchronization

In case of sync signal loss, the MU320E enters the **holdover** state, which lasts approximately 60 seconds, during this time the MU320E, will retain the sync status as locked. After that the MU320E enters the **free running** and will alarm sync not locked status. When the sync signal is recovered the MU320E runs a process of resynchronization that depends on the duration of the time sync loss.

There are two kind of resynchronization depending on the difference between the internal clock time and the received time:

- Clock difference  $\leq 5\text{ms}$ , the MU320E will adjust the synch pulse gradually until the internal generated PPS reaches the locked zone.
- Clock difference  $> 5\text{ms}$ , the resynchronization will be made by a phase shift to the new reference

The table below shows the behavior of *SmpSynch* flag sent through Sampled Values considering the MU320E Synchronization state, the Time Traceable flag from the time source and the grandmaster clockClassTime.

MU320E State	Time Traceable	Grandmaster clockClassTime	SmpSynch
Free-Running	Any	Any	Free-Running (None)
Locked/Holdover	False	Any	Local
Locked/Holdover	Any	Other than 6 or 7	Local
Locked/Holdover	Any	6	Global
Locked/Holdover	True	7	Global

## 5 Mode/Behavior

It is possible to configure the MU320E according to the mode and behavior described in IEC 61850-7-4 edition 2.

The configuration of the mode/behavior is carried out by controlling the Data Attribute Oper in the Data Object Mod in the LN (Logical Node) LLNO of the MU320E Logical Devices (LD).

The mode/behavior can be configured using the MU320E configuration software, by MMS command and by binary inputs. Chapter 5: Operation, Section 6 MMS shows the address to configure the mode/behavior via MMS.

The Mode/Behavior is configured in the IED tab Chapter 4: Configuration , section 9.1.4. Mode/Behavior.

The MU320E will not come into operation mode, and will not lights up IN SERVICE indicator, before the first configuration

---

## 6 MMS Interactions

The MU320E has all its interval variables implemented according the IEC 61850. Whichever data attribute referenceable in a dataset can be sent via MMS using either Polling or Report control blocks 9.5.4 Publishing Report Control Blocks.

The MU320E can connect to 20 MMS clients simultaneously.

---

## 7 Quality bits

Below are the quality bits that the MU320E support.

---

### 7.1 Sampled Values Quality Bits

<b>Validity</b>
Good
Invalid
Questionable
OutOfRange
Overflow
BadReference
Failure
<b>Source</b>
Process
Test
Derived

## 7.2 Goose and MMS Quality Bits

<b>Validity</b>
Good
Substituted
Questionable
Invalid
<b>Source</b>
Process
Test

## 8 Signaling Health of the MU320E

It is possible to alarm via GOOSE the health of the device using the logical nodes PhyHealth and Health.

The health status is divided into three situations:

- **OK:** Device is totally functional, no alarms reported. IN SERVICE LED: ON; ALARM LED: OFF; IN SERVICE RELAY: OPEN.
- **WARNING:** The device is functional, but has reported alarms. IN SERVICE LED: ON; ALARM LED: ON; IN SERVICE RELAY: OPEN.
- **ALARM:** The device is not functional. IN SERVICE LED: OFF; ALARM LED: ON; IN SERVICE RELAY: CLOSED.

The LN PhyHealth is found at *MU320BASE>LPHD>PhyHealth*.

The LN Health is found at *MU320BASE>LLN0>Health*.

For details of what conditions leads to change MU320E Health please use the table below

Health Signaling on MU320E		
Status	Condition	Cause
Warning	Synch quality not OK	Bad Sync quality, no PTP/IRIG-B signal available
	Internal voltages above limit	Hardware Issues
	Internal Temperature above limit	Internal temperature above limit for exceeded time*
	PRP Redundancy - Link failure	One of the links PRP are failed
	Sample quality <i>questionable</i>	Acquisition above clipping limit or calibration issue
	Analog channel not calibrated	Calibration not made or outside device limits
Alarm	Invalid Module	Installed modules not according to CORTEC and License
	Module not detected	Module configured in CORTEC and Licence but absent or failed
	Eth1 not connected – No Redundancy	Eth1 disconnected or failed and no redundancy configured
	Eth1 and Eth2 disconnected – PRP Redundancy	Eth1 and Eth2 disconnected or failed with configured redundancy
	Sample quality <i>invalid</i>	Numerical overflow in acquisition or Fuse Fail detected on TVTR

\* Internal temperature of 110°C for more than 16h, this temperature reflects an ambient temperature above of 80°C.

## 9 Network Traffic Control

A filtering or segregation mechanism in the switches allows restricting multicast traffic only to those IEDs that are subscribers of the GOOSE or SV traffic. If this filtering is not applied, the network is flooded by multicast messages, which results in excessive bandwidth consumption and burdens the IEDs with unnecessary processing of unwanted traffic.

Note:

The MU320E Ethernet ports are not designed to receive the high throughput. In case high throughput messages are being read by the MU320E Ethernet ports, excessive processing will be demanded in order to interpret the messages, which can cause unstable and undesirable behavior of the MU320E. To avoid so, multicast filtering or VLAN segregation shall be configured in the managed switches of the application.

### 9.1 MAC Parity Filtering

The MU320E has a MAC bit parity counter filter in the FPGA level of the hardware. Configuring the GOOSE and Sampled Values messages within the network with MAC addresses with different parities in the fifth octet will avoid messages collision between GOOSE and Sampled Values. The filter will discard undesirable messages before they get to the Operational System level and overload the device processing.

The picture below displays the level in which the unwanted messages are discarded.

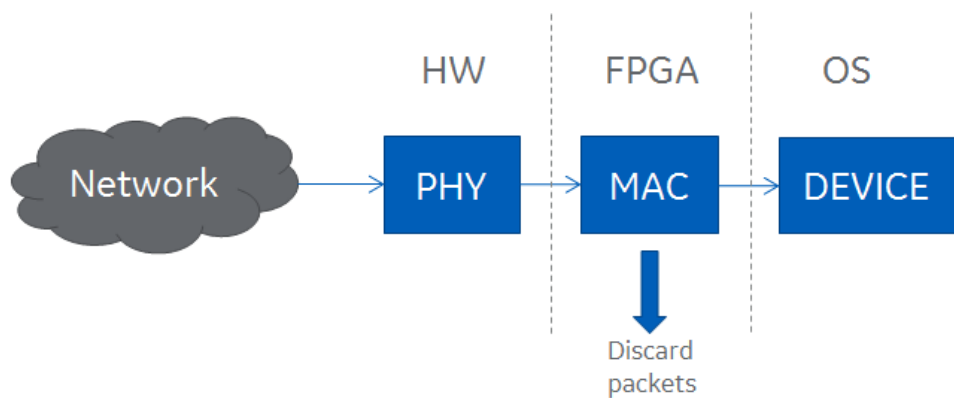

The table below exemplifies the suggested configuration is the MAC address of GOOSE and Sampled Values messages. Note that the fifth octet should not have the same parity.

---

GOOSE	Sampled Values
01-0C-CD-01-00-XX	01-0C-CD-04-01-XX

---

## 9.2 Sampled Values Filtering

To avoid unnecessary demand of the processor, the MU320E has an internal filter that will not allow Sampled Values messages to be processed. The MU320E does so by blocking any message with the Ethertype 88-BA that is present in all Sampled Values messages according to IEC 61850-9-2.

# MU320E

## Integrated Merging Unit

### Chapter 6: Communication

The equipment has two communication interfaces, which are used for station and process bus.

Analog and digital values and GOOSE data packets are sent for the appropriate IED through the communication interfaces. It is also possible to access the configuration software, read and transmit configuration for the equipment through the same interfaces.

This chapter contains the information for MU320E communication, such as communication interfaces, protocols, and connection diagrams.

#### 1 Communication Interfaces

The MU320E has two communication interfaces, listed and shown below:

- 100BASE-FX Ethernet interface using LC connector (B01);
- 100BASE-FX Ethernet interface using LC connector (B02);

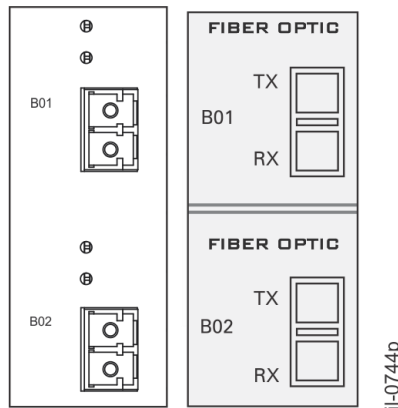

*Communications Ethernet interfaces*

Each Ethernet interface has two LED indicators, for RX and TX connections, which lights up when the link is receiving and transmitting data, respectively.

Depending on the CORTEC configuration, the MU320E interfaces present different functionalities regarding the protocols that they support.

When the redundancy protocol PRP is enabled both Ethernet ports (1 and 2) will be enabled to: Sampled Values (IEC61850-9-2), GOOSE (IEC61850-8-1), PTP, MMS and configuration. And they will have the same IP address.

When PRP is not enabled:

- Ethernet port 1 will be enabled to: Sampled Values (IEC61850-9-2), GOOSE (IEC61850-8-1), PTP, MMS (ISO 9506) and configuration (TCP/IP, SSHv2);
- And the Ethernet port 2: MMS (ISO 9506) and configuration (TCP/IP, SSHv2).

## 1.1 Ethernet Ports Default IP Address

The tables below show the Ethernet ports default IP address:

Ethernet 1 interface default settings	
IP Address	192.168.0.199
Net mask	255.255.255.0
Broadcast	192.168.0.255

Ethernet 2 interface default settings*	
IP Address	192.168.1.199
Net mask	255.255.255.0
Broadcast	192.168.1.255

\* When PRP is not enabled.

## 2 Communication through Network Using the Optical Ethernet Interface

To communicate with MU320E via Ethernet network, the IP address, net mask, and broadcast of the equipment must be on the same network of the computer.

In order to verify whether the equipment connection is correctly set up, connect the equipment on the same network of the computer and, using a command line terminal, run a ping command to the IP address of the equipment.

### 2.1 Communication Ports and Protocols

To guarantee full access permission for equipment communication via Ethernet, it is necessary to unblock the following ports and protocols:

PORT	PROTOCOL	USE
22	SSH	Access to equipment configurations and download Log files
102	MMS	Communication with the supervisory system
319	PTP (layer 3)	Layer 3 PTP Synchronization
320	PTP (layer 3)	Layer 3 PTP Synchronization

### 2.2 Communication Setup

It is possible to configure the communication interface (Ethernet IP address and communication name) using the application software.

# MU320E

## Integrated Merging Unit

### Chapter 7: Installation

To start using the MU320E, the first step is to install and connect the equipment to the system that will be protected.

For correct installation and connection, it is necessary that the user knows the key features and technical specifications, presented in Chapter 1.

This chapter contains the information for the MU320E installation, such as characteristics of the connection terminals, location and function of each connection and typical voltage and current connections. Following the guidelines in this chapter, the MU320E will be able to function properly.

---

#### 1 Handling the Goods

Our products are of robust construction but require careful treatment before installation on site. This section discusses the requirements for receiving and unpacking the goods, as well as associated considerations regarding product care and personal safety.



Before lifting or moving the equipment you should be familiar with the Safety Information chapter of this manual.

---

#### 1.1 Receipt of the Goods

On receipt, ensure the correct product has been delivered. Unpack the product immediately to ensure there has been no external damage in transit. If the product has been damaged, make a claim to the transport contractor and notify us promptly.

For products not intended for immediate installation, repack them in their original delivery packaging.

---

#### 1.2 Unpacking the Goods

When unpacking and installing the product, take care not to damage any of the parts and make sure that additional components are not accidentally left in the packing or lost. Do not discard any CDROMs or technical documentation. These should accompany the unit to its destination substation and put in a dedicated place.

The site should be well lit to aid inspection, clean, dry and reasonably free from dust and excessive vibration. This particularly applies where installation is being carried out at the same time as construction work.

---

## 1.3 Storing the Goods

If the unit is not installed immediately, store it in a place free from dust and moisture in its original packaging. Keep any de-humidifier bags included in the packing. The de-humidifier crystals lose their efficiency if the bag is exposed to ambient conditions. Restore the crystals before replacing it in the carton. Ideally regeneration should be carried out in a ventilating, circulating oven at about 115°C. Bags should be placed on flat racks and spaced to allow circulation around them. The time taken for regeneration will depend on the size of the bag. If a ventilating, circulating oven is not available, when using an ordinary oven, open the door on a regular basis to let out the steam given off by the regenerating silica gel.

On subsequent unpacking, make sure that any dust on the carton does not fall inside. Avoid storing in locations of high humidity. In locations of high humidity the packaging may become impregnated with moisture and the de-humidifier crystals will lose their efficiency.

The device can be stored between –25° to +70°C for extended period or between -40°C to + 85°C for up to 96 hours (see technical specifications).

---

## 1.4 Dismantling the Goods

If you need to dismantle the device, always observe standard ESD (Electrostatic Discharge) precautions. The minimum precautions to be followed are as follows:

- Use an antistatic wrist band earthed to a suitable earthing point.
- Avoid touching the electronic components and PCBs.

---

## 2 Normal Use of the Equipment

In order to maintain the equipment integrity, levels of protection and assure user safety, the MU320E shall be installed in an enclosed panel with recommended ingress protection rating of IP54 or above.

The enclosing panel shall ensure that the equipment rear connections and sides are unexposed and protected against impact and water, meanwhile maintaining adequate temperature and humidity condition for the devices. Furthermore, the equipment shall have all their rear connectors attached, even if not being used, in order to keep their levels of ingress protection as high as possible.

During the normal use of the device only its frontal panel shall be accessible.

---

## 3 Mounting the Device

### 3.1 Mechanical Installation

To install the MU320E in the panel, drill the necessary holes as described in Chapter 7 – Case Dimensions. The screws used for fixation are of the M6 type.

It is possible to order an optional support for installation of one or two units adapted to a 19-inch rack. To install either a single or two modules of MU320E use the optional supports shown in Chapter 7 – Case Dimensions.

For information about the equipment dimensions, refer to Chapter 9: Technical Specifications.

The equipment is designed for outdoor installation on an isolated panel. The panel must be properly designed for the environmental conditions to which its subject.

MU320E should always be sheltered from the weather. For indoor use, the equipment must be installed inside panel with IP41 (IEC) enclosure protection or minimal type 3 (NEMA). For outdoor use, the equipment must be installed inside panel with IP55 (IEC) enclosure protection or type 3, 3X, 3S or 3SX (NEMA), according to the local environmental conditions, complying the IEC 60529 and NEMA 250-2003 standards requirement.

The panels should be submitted to insulation test according to IEC 60255-5:2000 standard. (Have minimum insulation resistance of 10 MΩ and be submitted to test of dielectric voltage insulation of 2kV a.c.

An additional panel designed for the merging unit application environment may be provided upon request. For more information on panel options, please contact GE support.

---

## 4 Cables and Connectors

This section describes the type of wiring and connections that should be used when installing the device, as well as pin-out details.



Before carrying out any work on the equipment you should be familiar with the Safety Section and the ratings on the equipment's rating label.

In order to meet the EMC CISPR22 emission levels, the power supply, CT, VT and binary signals connection shall use screened (shielded) cables with screen coverage of 70%; Core wires should be as short as possible; The shield should be connected to any of the two functional earth terminal screws positioned on the upper and lower-middle parts of the frontal panel of the equipment through short pigtails. Recommended lug terminal to the pigtail end connection.

---

### 4.1 Power Supply Connections

The unit can be powered from DC or AC power within the limits specified in Chapter 9: Technical Specifications.

All power connections should use insulated flameproof flexible cable (BWF type) with a 2.5 mm<sup>2</sup> cross section, 70° C (158 °F) thermal class, and 750 V insulation voltages.

To reduce the risk of electrical shock, pre-insulated tubular pin terminals should be used on the ends of the power connections.

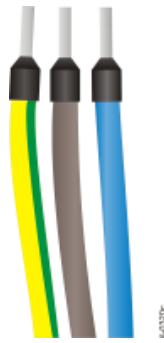

Pre-insulated tubular pin terminals

The pin terminals should be completely inserted into the connector supplied with the unit so that no metallic parts are exposed, according to the picture below.

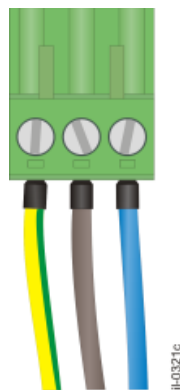

Supplied connector assembly

A 1.5 mm<sup>2</sup> ground straps shall be connected to the terminal marked with the protective earth symbol for safety.

For optimal electromagnetic compatibility, ground the unit by using a screened/shielded cable with insulated flexible wires of 4.0 mm<sup>2</sup> cross section connected to the rear panel of the device using the protective earth screw.

### 4.1.1 AC AND DC POWER CONNECTION

Figure below shows the wiring diagram for the AC and DC power connection. Phase or positive should be applied to terminal A04, neutral or negative to terminal A05, and ground to terminal A03.

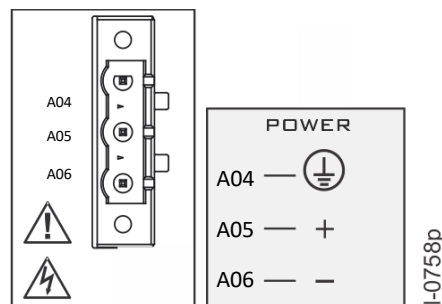

AC and DC power connection

For compliance with IEC 61010, install a suitable external switch or circuit breaker in each current-carrying conductor of MU320E power supply; this device should interrupt both the hot (+/L) and neutral (-/N) power leads. An external 10 A, category C, bipolar circuit-breaker is recommended. The circuit breaker should have an interruption capacity of at least 25 kA and comply with IEC 60947-2. The switch or circuit-breaker must be suitably located and easily reachable, also it shall not interrupt the protective earth conductor. For information about the nominal operating voltage range or maximum voltage applicable, power and frequency, refer to Chapter 9: Technical Specifications.

---

## 4.2 Powering Up

1. Before energizing the unit, be familiar with all the risk and attention indicators in the equipment's frame.
2. Connect the power supply (including the ground strap) to the appropriate terminals. The equipment will start the boot process.
3. The equipment performs a self-test procedure. At the end of the self-test, if it is operating and has already been configured, the IN SERVICE indicator lights up on the front panel of the equipment and the signaling contact IN SERVICE on the rear panel of the equipment will be on.
4. If is the first time using the equipment, it is necessary to configure it. Before the configuration, equipment will not be in service.
5. To turn off the unit, disconnect the power supply (including the ground strap) from the terminals. All front and rear panel indicators will turn off.

In case the unit does not behave in a way here described or if the ALARM indicator lights up, turn off the equipment and carefully check all power and signal connections. Repeat the procedure described and if the problem persists, please contact GE Vernova contact center.

For additional suggestions for problem diagnosis, refer to Chapter 6.



*Note:*

*The equipment will not come into operation mode, and will not light up the IN SERVICE indicator, before the first configuration*

---

## 4.3 Earth Connection

To ensure proper operation of the equipment under adverse conditions of electromagnetic compatibility, connect the protective earth terminal to the panel using a screened/shielded cable with insulated flexible wires of 4.0 mm<sup>2</sup> cross section. As shown in the figure below.

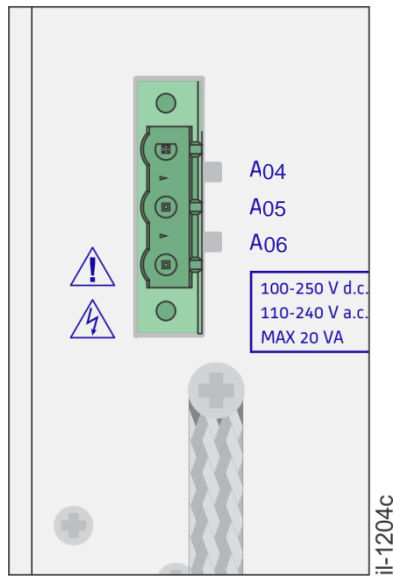

MU320E Earthing

Additionally, to meet the EMC CISPR22 emission levels, two other functional earth terminals are available on upper-middle and lower middle parts of the frontal panel (see Installation Chapter Section 3.1 MU320E Frontal Panel) of the equipment marked with the sing below:

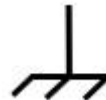

Power supply, CT, VT and binary signals shall use screened/shielded cable. Connect the shield of the cable to both functional earth terminals using short pigtailed with lug terminals.

## 4.4 IN SERVICE Contact

The MU320E has a contact for signaling equipment failure, located in Slot A, shown in figure below. The IN SERVICE contact is normally closed (NC) and it opens when the equipment goes into normal operation. In case of firmware or hardware failure or shutdown of the equipment, the contact will close.

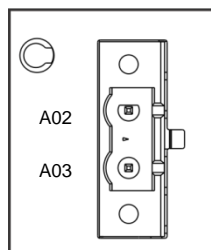

IN SERVICE contact for signaling equipment failure

For information about the IN SERVICE contact specifications, refer to Chapter 9: Technical Specifications.

For information about software installation, refer to Chapter 7: Installation.

Connections shall use insulated flexible wires of 1.0 mm<sup>2</sup> cross section, voltage rating of 300Vrms.

## 4.5 Optical IRIG-B Input

Time synchronization is provided by temporal signal format IRIG-B004. The IRIG-B ensures that the frequency of data acquisition stays constant and maintaining the internal clock synchronized.

The MU320E has an optical IRIG-B input, located in Slot B, shown in figure below.

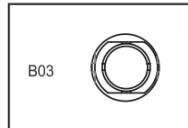

*Optical IRIG-B input*

The equipment signals SYNC on the front panel when the data acquisition frequency is according to the equipment's nominal acquisition frequency and the equipment's internal clock is updated.

To synchronize the equipment using fiber-optic input, use the appropriate fiber-optic type, considering its minimum curvature radius. For information about the optical input specifications, refer to Chapter 9: Technical Specifications.

---

## 4.6 Binary Inputs and Outputs

The binary inputs and outputs are supported in the slots C to H of the MU320E, allowing it to be combined with logic operations to be used in several applications.

There are three different models for Binary I/O cards:

- Model **B3**: 16 x 24/48/125/250 V binary inputs;
- Model **B4**: 6 x 24/48/125/250 V binary inputs and 8 x Form A binary outputs;
- Model **B5**: 6 x 24/48/125/250 V binary inputs and 4 x Form C + 2 x Form A binary outputs;
- Model **B6**: 6 x 24/48/125/250 V binary inputs and 8 x High Speed Form – A binary outputs;

The connections and polarities must follow what is identified through the sticker annexed to each board.

For binary inputs there are groups isolated channels. These groups are segregated through dashes and the polarities are identified through the negative signal ( - ), that represents the negative reference for the group and the positive signal ( + ), that represents the positive reference for the specific channel.

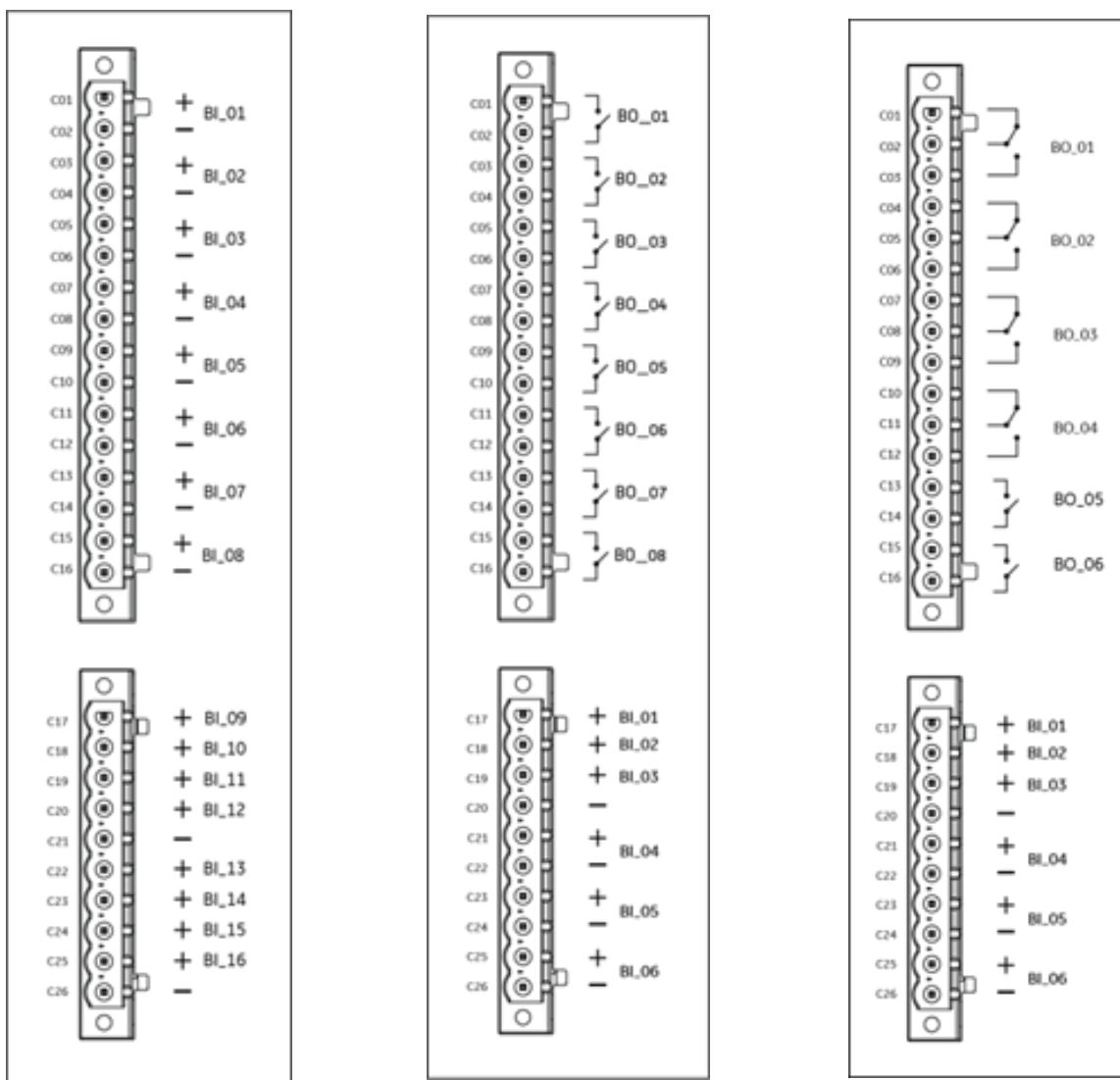

Binary board model B3

Binary board model B4

Binary board model B5

Please note that the MU320E can work with up to 100% of its digital inputs and 50% of its digital outputs energized simultaneously at the maximum ambient temperature (considering the maximum number of inputs/output available).

### 4.6.1 BINARY INPUTS

The digital inputs can be used to obtain information from the power system, for example, the state of circuit breakers.

All MU320E Binary Inputs channels are opto-isolated and the operational voltage level is software configurable.

**Note:**

*The channel inputs have configurable voltage levels, but the channel will not be protected if you configure a voltage level lower than your voltage reference.*

Connections shall use insulated flexible wires of 1.0 mm<sup>2</sup> cross section, voltage rating of 300Vrms.

For information about the digital input specifications, refer to Chapter 9: Technical Specifications.

---

## 4.6.2 BINARY OUTPUTS

The digital outputs can be used to control switching units as circuit breaker and recloser, for example, and announcements for remote signaling of events and status.

Connections shall use insulated flexible wires of 1.0 mm<sup>2</sup> cross section, voltage rating of 300Vrms.

For information about the digital output specifications, refer to Chapter 9: Technical Specifications.

---

## 4.7 Analog Inputs

Analog inputs convert the currents and voltages coming from the transformers and adapt to the appropriate level for the internal processing of the equipment. Each slot (G and H) provides 4 current inputs and 4 voltage inputs, as shown in figure below.

The current phases are monitored at inputs  $I_A$ ,  $I_B$ , and  $I_C$ . The neutral current is monitored by the  $I_N$  input and can be used to measure the fault current to ground (star point of the current transformer) or a current transformer to ground (for ground fault detection and determination of the directionality for ground faults).

The voltage phases are monitored at inputs  $V_A$ ,  $V_B$ , and  $V_C$ . The input  $V_X$  is used for monitoring neutral voltage.

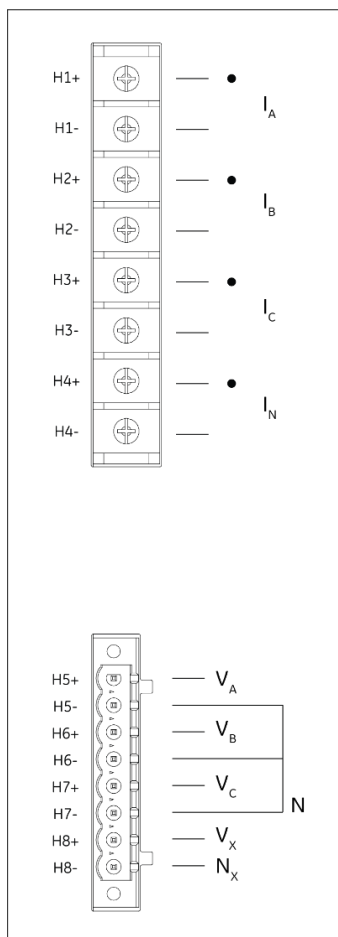

Voltage and current analog inputs

### 4.7.1 CURRENT ANALOG INPUTS

The MU320E has four current inputs  $I_A$ ,  $I_B$ ,  $I_C$  and  $I_N$  for analog board models. Connections shall use insulated flexible wires of 2.5 mm<sup>2</sup> cross section, 8 mm<sup>2</sup> ring terminal, and M3 holes, voltage rating of 300Vrms. Before making the electrical connection, make sure the signal is applied in accordance with the technical specifications of the equipment. For information about the analog current input specifications, refer to Chapter 9: Technical Specifications.

### 4.7.2 VOLTAGE ANALOG INPUTS

The MU320E has four voltage inputs  $V_A$ ,  $V_B$ ,  $V_C$  and  $V_X$ , for all analog models. Connections shall use insulated flexible wires of 1.5 mm<sup>2</sup> cross section and 5.08 mm pitch plug terminals voltage rating of 300Vrms. Before making the electrical connection, make sure the signal is applied in accordance with the technical specifications of the equipment. For information about the analog voltage input specifications, refer to Chapter 9: Technical Specifications.

## 5 Case Dimensions

### 5.1 MU320E Dimensions and Weight

Dimensions of the equipment	
Height	222 mm / 8.7 in (5 U)
Width	222 mm / 8.7 in (½ 19")
Depth	121 mm / 4.7 in
Weight	< 3.5 kg (< 7.72 lb)

MU320E dimensions are shown on figure below.

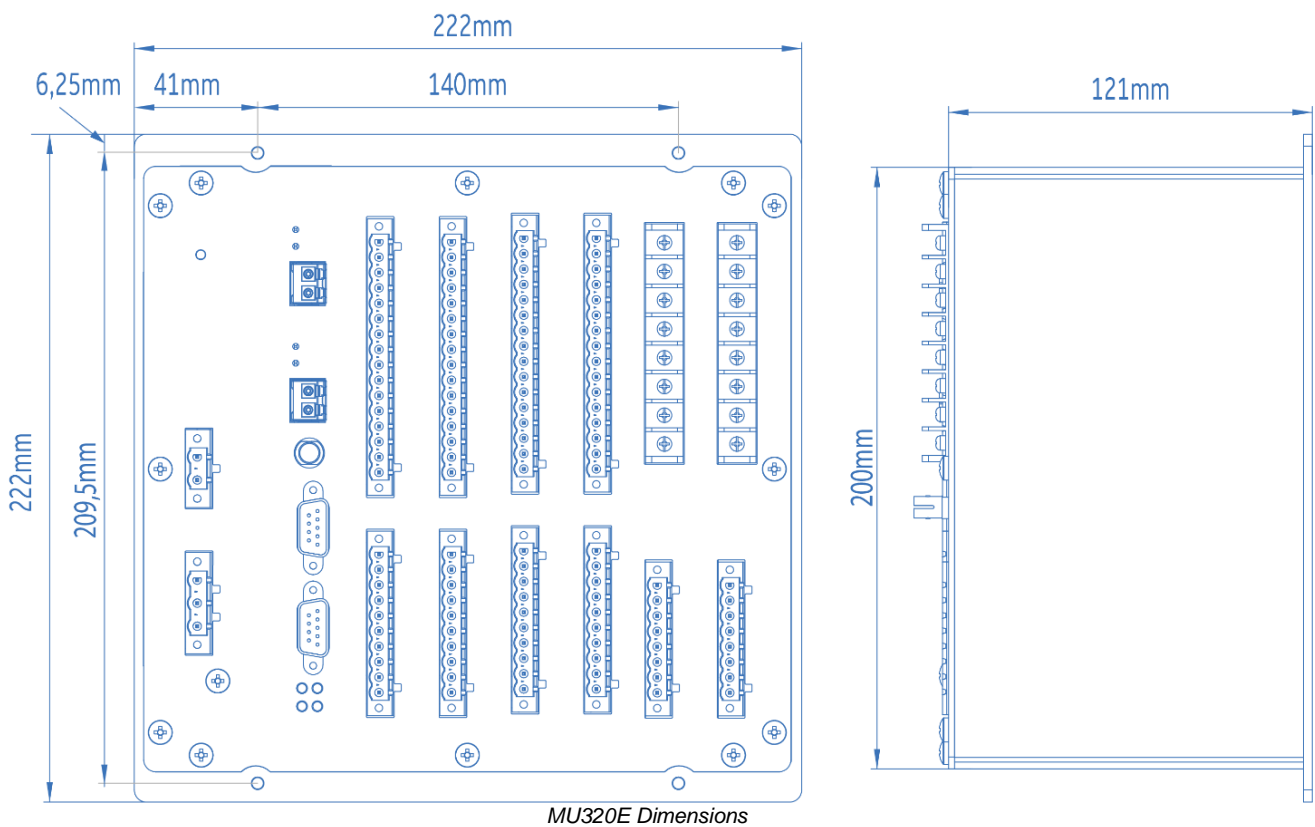

## 5.2 Panel Cutout

MU320E panel cutout is shown in the figure below.

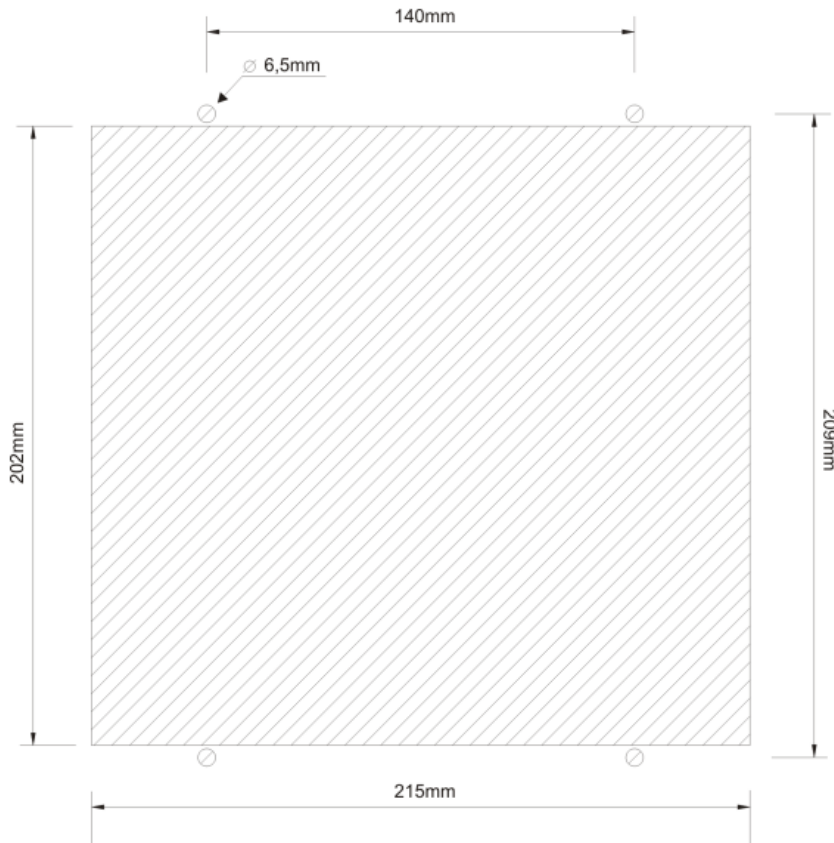

*Panel cutout for MU320E installation*

## 5.3 Accessories

MU320E accessories	
Q62	Double mounting chassis to install two MU320E in a 19-inch rack + blank plate to cover one cutout in case only one MU320E is being used.

### 5.3.2 MOUNTING CHASSIS FOR TWO MU320E (Q62)

Double mounting chassis to install two MU320E in a 19-inch rack is shown in figure below.

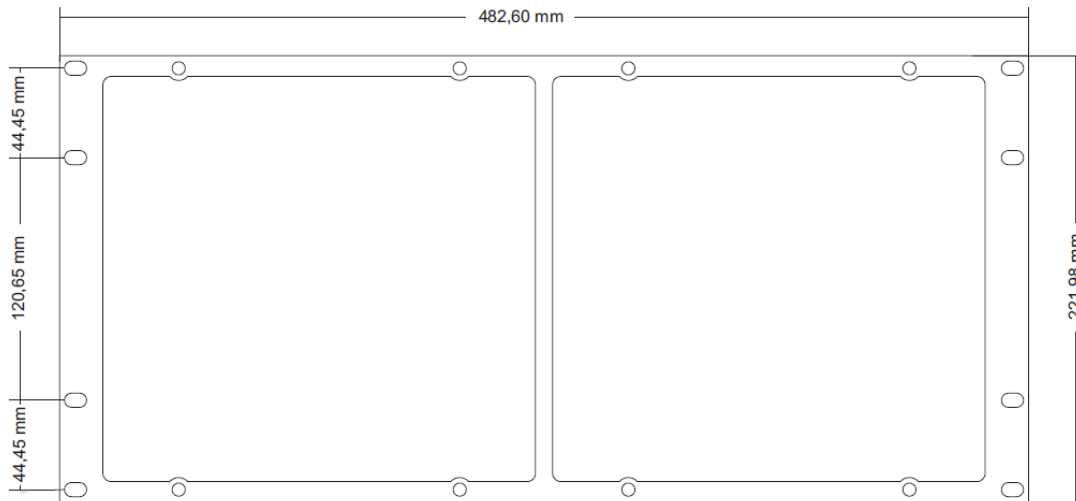

*Double mounting chassis to install two MU320E in a 19-inch rack*

## 6 Merging Unit Configurator Software Installation

### 6.1 Minimal requirements

The minimum hardware requirements, supported operational system and applications needed for the installation and implementation of the Merging Unit Configurator are described below.

**Minimum hardware requirements:**

- Processor 1 GHz or higher, 32-bit (x86) or 64-bit (x64);
- Minimum 1 GB RAM (32-bit) or 2 GB RAM (64-bit);
- Minimum 250 MB free space on disk;
- DirectX 9 or higher.

**Supported operational system:**

- Windows® 7 32-bit (x86) or 64-bit (x64).
- Windows® 10 32-bit (x86) or 64-bit (x64).

**Applications:**

- Microsoft dot.Net 4.6.2 version or higher;
- FTDI Driver 2.08.24 version or higher;
- Microsoft Visual C++ 2010 Redistributable Package (x86) SP1;
- Windows® Installer 3.1;

- Microsoft Visual C++ 2010 Redistributable Package (x86) (Must be installed even for x64 Windows®);
- Microsoft Visual C++ 2010 Redistributable Package (x64) (Must be installed only for x64 Windows®).

To install the MU320 Extended Configurator it is necessary be the system administrator. To verify if the user is the system administrator, access the Control Panel in Windows®, and go to Users Accounts.

## 6.2 Installing

The Merging Unit Configurator application is installed through execution of an installer file.

To install the software, follow the procedures below:

1. The initial installer screen will open. Click on <NEXT> button.

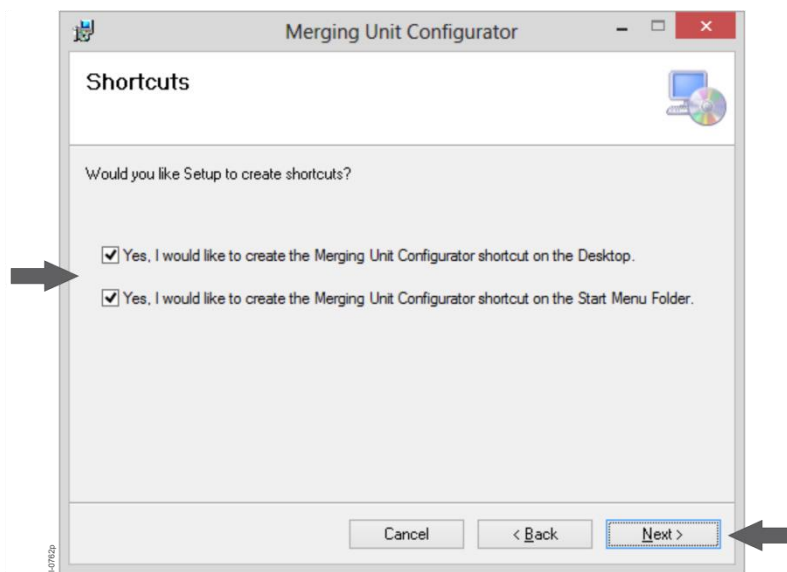

*MU320E Configurator initial installer screen*

2. Choose if want to create an icon on the desktop and/or include the software in the options menu of Windows® and click on <NEXT> button.

3. Choose the installation folder and confirm the installation clicking again on <NEXT > button. The software will be installed. This process can take a few minutes, please wait for the complete installation of the software.

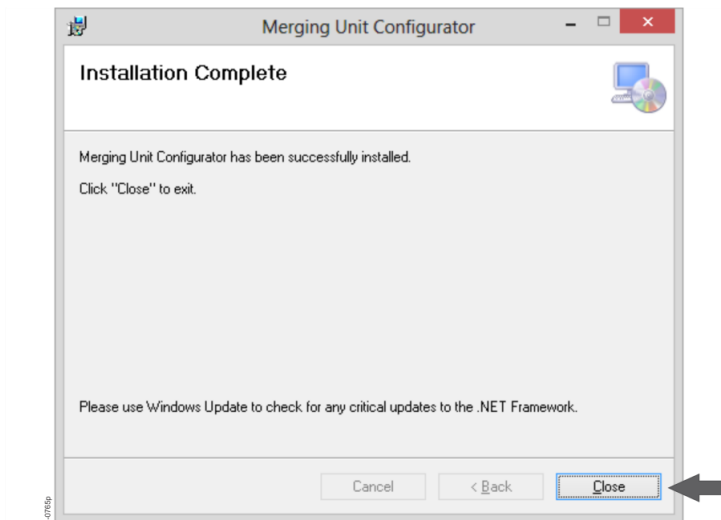

*Option to choose the installation folder*

**4.** After installation is finished, click on <CLOSE> button and the software will be ready for use.

Once the software is installed, a folder is created on the C: drive, where are saved the equipment files:

**C:\MU320 Extended Configurator**

If there is a previous version of software installed on the computer, it is necessary to manually remove the old version before performing the installation of new software.

## 6.3 Uninstalling

To uninstall the software, access the Control Panel in Windows® and go to Add or Remove Program option. Then select Merging Unit Configurator on the list, click on <Remove>, and follow the instructions.

The removal process can take a few minutes.

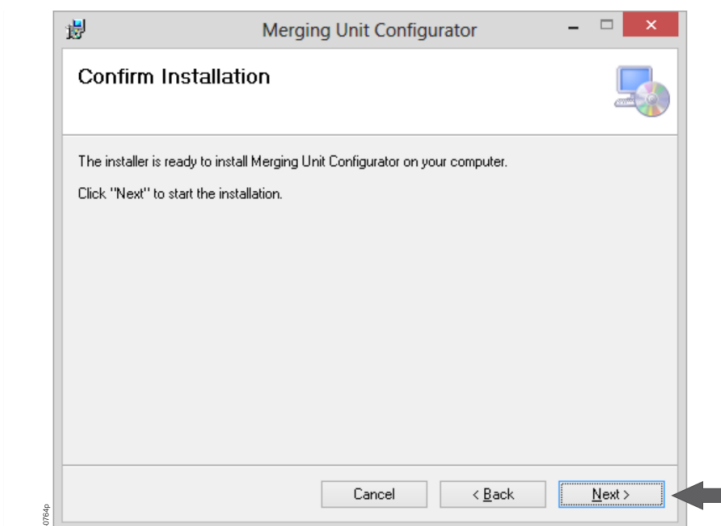

*Option to choose the installation folder*

**6.** Confirm the installation, clicking on the <NEXT> button.

---

# MU320E

## Integrated Merging Unit

### Chapter 8: Maintenance

This chapter provides information about proper equipment maintenance and troubleshooting.

The troubleshooting part of the chapter allows an error condition on the IED to be identified so that appropriate corrective action can be taken.



Before carrying out any work on the equipment you should be familiar with the contents of the Safety Section.

---

#### 1 Maintenance

##### 1.1 Synchronization Failure (SYNC Indicator does not light up)

When the unit is operating without a synchronization reference in the IRIG-B optical input, the failure is signaled in the Sync indicator of Local interface, that does not light up. When a synchronization failure is detected, the following actions are recommended: Check for configuration being transmitted to the unit. During transmission, the unit should momentarily go out of operation to reboot. This behavior is normal and no action is required. The SYNC indicator will light up as soon as the unit resumes operation.

Make sure the fiber optical cable is properly connected to the IRIG-B input, as the specifications in Chapter 9: Technical Specifications.

---

##### 1.2 Cleaning Instructions

Before cleaning the equipment, make sure that the primary voltage is removed. If the exterior needs cleaning, only use a dry cloth. No internal cleaning is required.

---

##### 1.3 Instructions for Equipment Repair Service

To request equipment repair service, contact GE Vernova to check for shipping options and receive the return authorization number. To contact GE Vernova, please view the back cover of this manual.

The equipment shall be packed in its original package or a suitable package to protect against impacts and moisture.

Send equipment to the address provided by the repair department, including the identification and the technical assistance code supplied on the outside of the package.

## 2 Procedure to reset password and IP address

In situations where the IP or password is lost or, for some reason it is wanted to reset the device to its default IP and password it is needed to execute the following the procedure:

1. Cross-Connect the ethernet interfaces 1 and 2 creating a loopback connection (tx from interface 1 to rx from interface 2 and tx from interface 2 to rx from interface 1)
2. Power on or reboot the MU320E
3. If loopback is detected, passwords and interface 1 IP address will be reset to factory default values
4. Remove the loopback connection.

---

## 3 Firmware Update

The MU320E performs a secure firmware update, using checksum to validate integrity and a digital signature to ensure authenticity. The file transfer protocol used to update the firmware is secure (SFTP). The firmware file used a key generator based on 2048-bit long RSA key pair and a SHA-256 hash algorithm.

# MU320E

## Integrated Merging Unit

### Chapter 9: Technical Specifications

This chapter describes the technical specifications of the product.

#### 1 Specifications

##### 1.1 Power Supply

Power Supply		
Operating nominal voltage	125-250 Vdc, 110-240 Vac	48 Vdc
Maximum voltage range	100-300 Vdc, 88-264 Vac	38 – 60 Vdc
Power consumption	35W @ 0.45A, 80VA @ 0.9A	45W @ 0.7A
Frequency	50 / 60 Hz, $\pm$ 3 Hz	---
Isolation Level	3.1 kVdc (for 1min. in 2000m of altitude)	

##### 1.2 IN SERVICE Contact

IN SERVICE contact specifications	
Description	Dry contact relay, normally closed
Switching Voltage	250 V (AC and DC)
Permissible current continuous	5 A
Maximum voltage	300 (AC and DC)
Making Capacity	15 A, 4 sec
Breaking Capacity	40W Resistive, 25 W/VA L/R = 50ms
Dropout time	< 5 ms
Withstand voltages across open contacts	1000V rms
Permissible short time value for 0.2s	30A

##### 1.3 Optical IRIG-B Input

Optical IRIG-B input specifications	
Signal	IRIG-B004
Wavelength	820 nm
Fiber type	Multimode 62.5 / 125 $\mu$ m Multimode 50 / 125 $\mu$ m
Connector	ST
Sensitivity	- 24 dBm

## 1.4 Internal Oscillator

Internal oscillator specifications	
Accuracy	< 1μs
Drift when not locked	±0.016PPM (1.44 milliseconds/day)
Max Holdover	60s

## 1.5 Binary Inputs

Digital Inputs specifications				
Nominal Voltage	24 V	48 V	125 V	250 V
Level Low	08 V	10 V	40 V	75 V
Level High	17 V	19 V	85 V	160 V
Impedance	15 kΩ	16 kΩ	82 kΩ	164kΩ
Burden	< 0.05 W	< 0.2 W	< 0.25 W	< 0.5 W
Continuous Overload <sup>1</sup>	50 V	100 V	170 V	340 V

<sup>1</sup> The digital inputs are protected against continuous reverse polarity for the nominal voltage

## 1.6 Binary Outputs

Digital outputs specifications	
Description	Dry contact relay. Form-C or Form-A
Maximum switching voltage	300 Vdc
Maximum continuous current	5 A
Make and short-time carry current	30A, 0.2s
Breaking Capacity	40 W Resistive, 25 W/VA L/R = 40ms
Operation time	< 5 ms, under minimum load of 1A
Dropout time	< 15 ms
Protection device across contacts	MOV (Metal Oxide Varistor) Rated @ 250Vac/320Vdc

High Speed High Break Digital outputs specifications	
Description	Form-A High Speed High Break contact using IGBT technology
Maximum switching voltage	300 Vdc
Maximum continuous current	10 A
Make and short-time carry current	30A, 0.2s
Breaking Capacity	Maximum 10A @ L/R = 40ms
Operation time	< 0.2 ms
Dropout time	< 25 ms
Burden	Per energized output relay: ~30mA @12V [360mW]
Protection device across contacts	MOV (Metal Oxide Varistor) Rated @ 250Vac/320Vdc
Max Number of operation	10000

## 1.7 Analog Acquisition

Analogue acquisition specifications	
Resolution	16 bits
Sampled Values Profiles	Protection (80 spc) and Measurement (256 spc)
Sampling Frequency	50 Hz: Protection Profile: 4000 Hz Measurement Profile: 12800 Hz 60 Hz: Protection Profile: 4800 Hz Measurement Profile: 15360 Hz
Frequency range	DC to 1 kHz
Group delay	< 1.1ms

## 1.8 Current Inputs

Current inputs specification			
Characteristic	Standard Input (P5)	Standard Input (P1)	High Accuracy Inputs(ME)
Nominal Current (In)	5 A	1 A	1 A
Nominal frequency	50/60Hz	50/60Hz	50/60Hz
Current range (rms)	0.25 ... 200A	0.05 ... 40A	0.005... 10 A
Burden In	< 0.05 VA	< 0.01 VA	< 0.02 VA
Continuous overload (rms)	20 A (4 x In)	4 A (4 x In)	10 A
AC current thermal withstand 1s (Ith rms)	200 A (40 x In)	40 A (40x In)	20 A
Insulation	> 2.2 kV	> 2.2 kV	> 2,2 kV

Current inputs Accuracy (P5/P1)		
Range	Magnitude Error	Phase Error
0.05 In ... 0.2 In	< ± 2.5% rd	< ± 90' (± 1.5°)
0.2 In ... 0.8 In	< ± 0.75% rd	< ± 45' (± 0.75°)
0.8 In ... 4 In	< ± 0.5% rd	< ± 30' (± 0.5°)
4 In ... 40 In	< ± 1% rd	< ± 60' (± 1.0°)

Current inputs High Accuracy (ME)		
Range	Magnitude Error	Phase Error
0.05 In ... 0.2 In	< ± 0.6% rd	< ± 15' (± 0.3°)
0.2 In ... 0.8 In	< ± 0.2% rd	< ± 8' (± 0.15°)
0.8 In ... 4 In	< ± 0.1% rd	< ± 5' (± 0.1°)

- rd – refers to errors of the reading value

## 1.9 Voltage Inputs

Voltage inputs specifications		
Characteristic	Standard Input	High Accuracy Input
Nominal Voltage (Vn)	115 V	115 V
Nominal frequency	50/60Hz	50/60Hz
Voltage range	10 V ... 460 V	10 V ... 230 V
Burden Vn	< 0.1VA	< 0.1VA
Continuous overload	230 V (2 x Vn)	230 V (2 x Vn)
Maximum overload (1 s)	460 V (4 x Vn)	460 V (4 x Vn)
Insulation	> 3,5 kV	> 3,5 kV

Voltage inputs Accuracy (P5/P1)		
Range	Magnitude Error	Phase Error
0.08 Vn ... 2 Vn	< ± 0.5% rd	< ± 20' (± 0.35°)
2 Vn ... 4 Vn	< ± 1.0% rd	< ± 60' (± 1.0°)

Voltage inputs High Accuracy (ME)		
Range	Magnitude Error	Phase Error
0.08 Vn ... 2 Vn	< ± 0.1% rd	< ± 5' (± 0.1°)

- rd – refers to errors of the reading value

## 1.10 Optical Ethernet Ports

Optical Ethernet ports specification	
Interface	100BASE-FX
Bitrate	100 Mbps
Wavelength	1300 nm
Connector	LC
Fiber type	Multimode 62.5 / 125 μm Multimode 50 / 125μm
Emission power	-20 dBm
Sensitivity	-32 dBm
Maximum applicable power	-14 dBm

## 1.11 Serial Ports

Serial ports specification	
Interface	RS232
Use	Device configuration and software upgrade
Bit Rate	115200 bps
Connector	DB9 (female), standard DTE

## 1.12 Environment Conditions

Environment conditions specification	
Operating temperature range	-40 °C (-40 °F) ... +55°C (+131°F)
Tested as per IEC 60068-2-1:2013	-40°C (-40°F)
Tested as per IEC 60068-2-2:2013	+85°C (+185°F)
Maximum operating altitude	2000 m (6560 ft)
Relative humidity	0 ... 95 %, noncondensing
Temporarily permissible temperature under operation	-40 °C (-40 °F) ... +70°C (+158°F) (Tested for 96 hours with 50% of binary I/O continuously activated)

Enclosure Protection IEC 60529	
Front flush mounted with panel	IP40
Rear and sides	IP10

## 1.13 Dimensions and Weight

Dimensions of the equipment	
Height	222 mm / 8.7 in (5 U)
Width	222 mm / 8.7 in (½ 19")
Depth	121 mm / 4.7 in
Weight	< 3.5 kg (< 7.72 lb)

MU320E dimensions are shown on figure below.

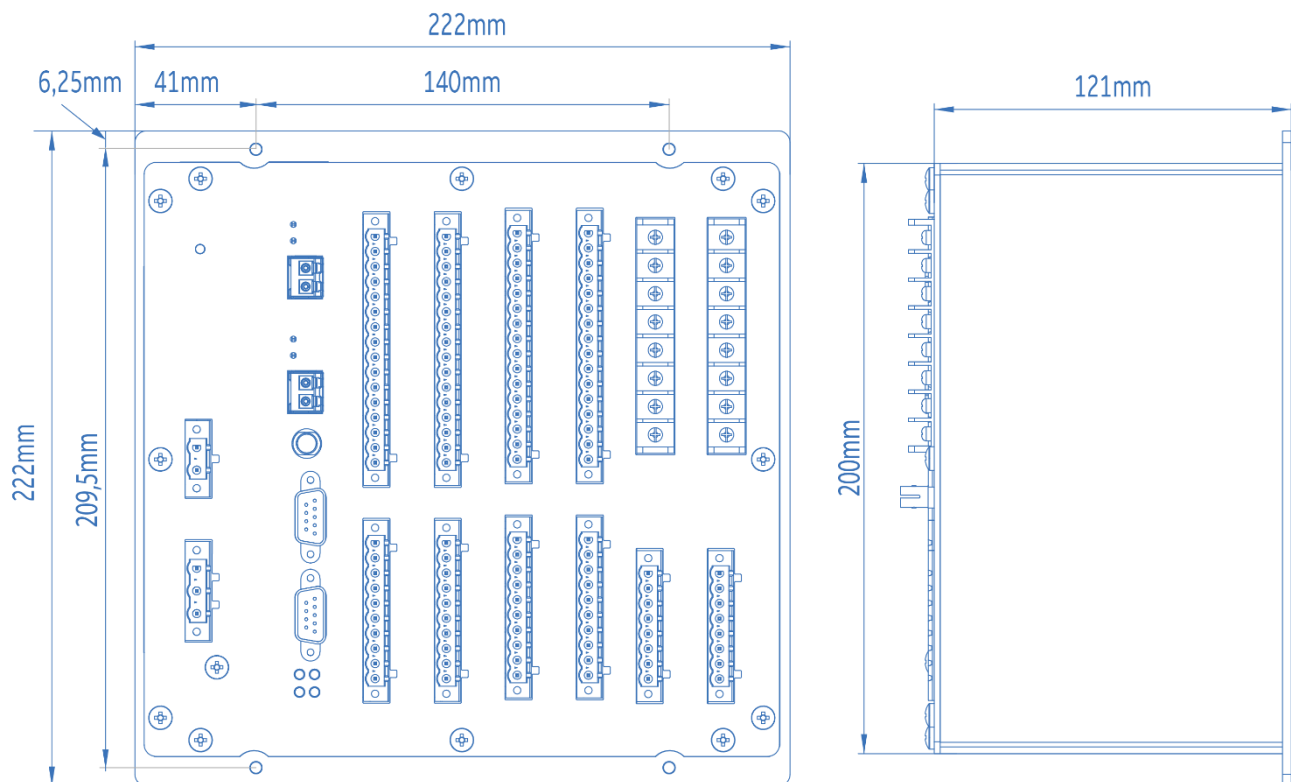

MU320E Dimensions

## 1.14 Type Test MU320E

EMC tests were performed according to IEC 60255-26 referring to the following standards.

Type Tests MU320E		
Test	Standard	Level
Electrostatic discharge	IEC 61000-4-2:2008	6kV contact / 8kV air (level 3)
RF immunity	IEC 61000-4-3:2006	10 V/m (level 3)
Fast transient disturbance	IEC 61000-4-4:2012	Zone A - 4kV @ 5kHz
Surge immunity	IEC 61000-4-5:2005	Zone A Differential mode: 4kV Common mode: 2kV
Conducted RF immunity	IEC 61000-4-6:2008	10 V/m (level 3) 0.15 MHz to 80 MHz
Power magnetic immunity	IEC 61000-4-8:2009	30A/m continuous - 300A/m @ 1s (level 4)
Voltage dip, short interruptions and voltage variation immunity tests	IEC 61000-4-11:2004	AC dips (residual%) 0% - 1/1 cycles (50/60Hz) 40% - 10/12 cycles (50/60Hz) 70% - 25/30 cycles (50/60Hz) AC interrupt (residual%) 0% - 250/300 cycles (50/60Hz)
	IEC 61000-4-29:2000	DC dips (residual%) 0% - 10ms 40% - 200ms 70% - 500ms DC interrupt (residual%) 0% - 5s
Power Frequency	IEC 61000-4-16:1998	Zone A Differential mode: 150Vrms Common mode: 300Vrms
Voltage ripple	IEC 61000-4-17:1999	Test level: 15 % of rated dc. value Test frequency: 100/120Hz, sinusoidal waveform
Damped oscillatory wave immunity test	IEC 61000-4-18:2006	Voltage oscillation frequency: 1MHz Differential mode: 1kV peak voltage Common mode 2,5kV peak voltage
Gradual Startup	IEC 60255-26:2013	Shut-down ramp: 60s Power off: 5min. Start-up ramp: 60s
Radio-frequency disturbance	CISPR11:2009 (below 1GHz)	Radiated emission below 1GHz - class A 30 MHz to 230 MHz 40 dB(μV/m) quasi peak at 10 m 50dB (μV/m) quasi peak at 3m 230 MHz to 1 000 MHz 47 dB(μV/m) quasi peak at 10 m 57dB (μV/m) quasi peak at 3m
Radiated emission	CISPR22:2008 (above 1GHz)	1 to 3 GHz - 56dB(μV/m) Average; 76dB (μV/m) peak at 3m 3 to 6 GHz - 60dB(μV/m) Average; 80dB (μV/m) peak at 3m
Conducted emission	CISPR22:2008	0.15MHz to 0,50MHz; 79dB(μV) quasi peak; 66dB(μV) average 0.5MHz to 30MHz; 73dB(μV) quasi peak; 60dB(μV) average

Safety tests	
Standard	Level
IEC 60255-27:2013	Impulse - 5KV Dielectric withstand - 2,2kVrms for 60 seconds Insulation resistance > 100MΩ @ 500Vdc

Environmental tests		
Test	Standard	Level
Cold	IEC 60068-2-1	-40°C, 16 hours (Cold operational)
	IEC 60068-2-1	-40°C, 16 hours (Cold storage)
Dry heat	IEC 60068-2-2	+85°C, 16 hours (Dry heat)
	IEC 60068-2-2	+85°C, 16 hours (Dry heat operational)
	IEC 60068-2-2	+85°C, 16 hours (Dry heat storage)
Damp heat Cyclic	IEC 60068-2-30	+25°C ± 3°C – 95% ±3% RH +55°C ± 2°C – 93% ±3% RH 6 of 24 hours (12h + 12h) cycles
Change of temperature	IEC 60068-2-14	-40°C to 55°C / 9 hours / 2 cycles
Damp heat	IEC 60068-2-78	+40°C ±2°C –93% ±3% RH –10 days
Vibration	IEC 60255-21-1	Class 2
Shock	IEC 60255-21-2	Class 1
Bump	IEC 60255-21-2	Class 1
Seismic	IEC 60255-21-3	Class 2



# MU320E

## Integrated Merging Unit

### Chapter 10: Wiring Diagrams

This chapter contains the all the possible wiring diagrams for the analogue inputs. For further details on the inputs, refer to Chapter 7: Installation.

#### 1 Current Connections

The diagram shown in the figure below represents a typical connection for three CTs and  $I_N$  from the neutral point in the equipment terminals.

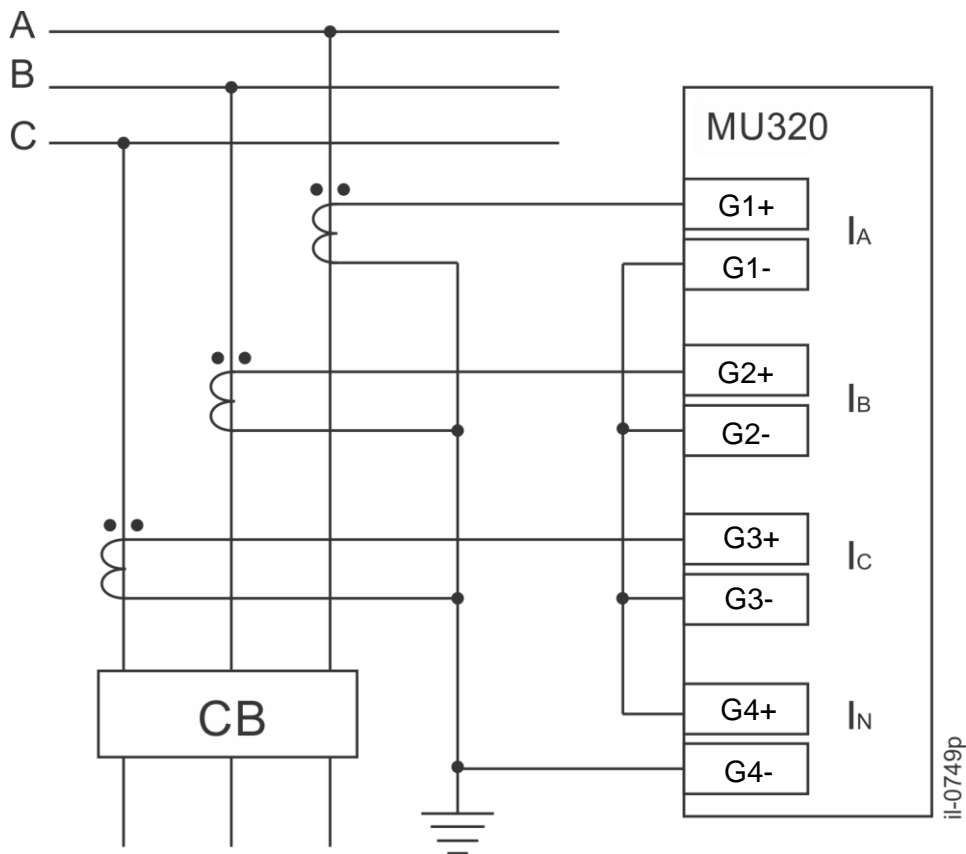

Typical current connection diagram

The diagram shown in the figure below represents a typical connection for three CTs for the current phases and  $I_N$  from the residual CT.

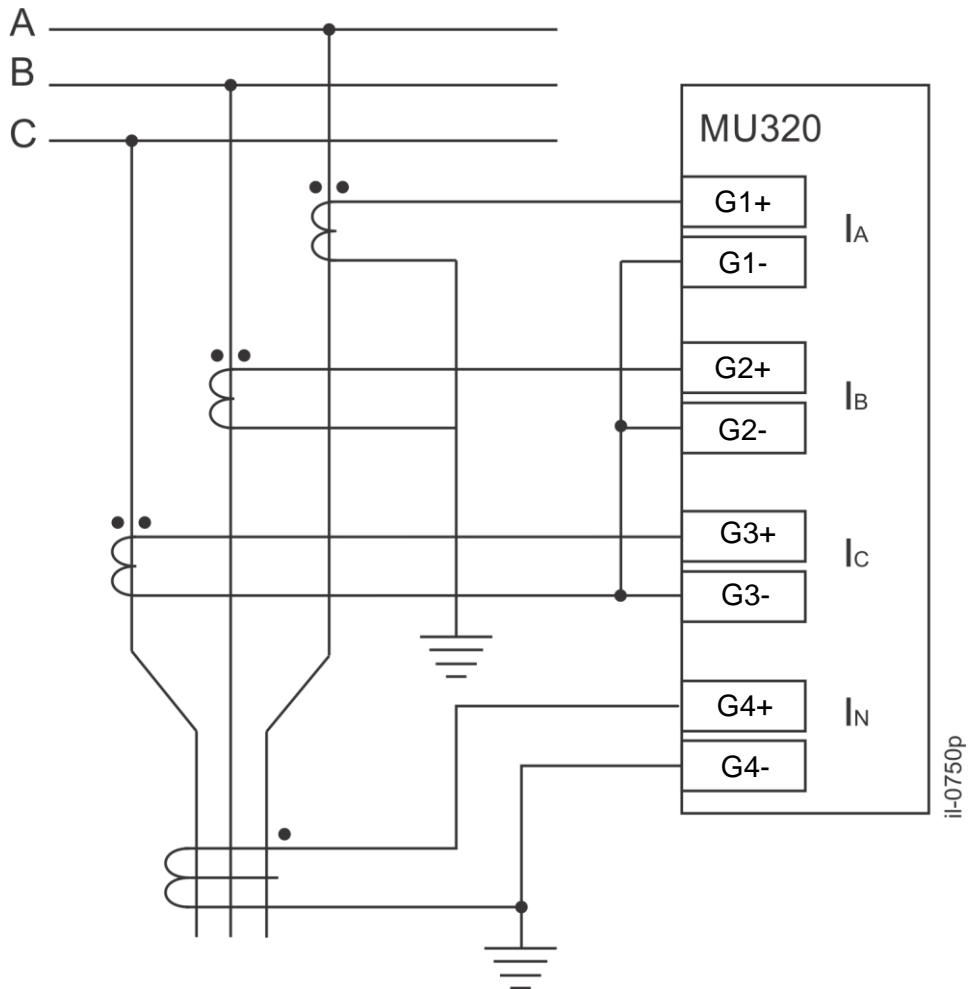

Typical current connection diagram with  $I_N$  from the residual CT

## 2 Voltage Connections

The figure below shows a typical installation of a VT using WYE-WYE connection for phase measurement and a WYE-Broken Delta connection for 3V0.

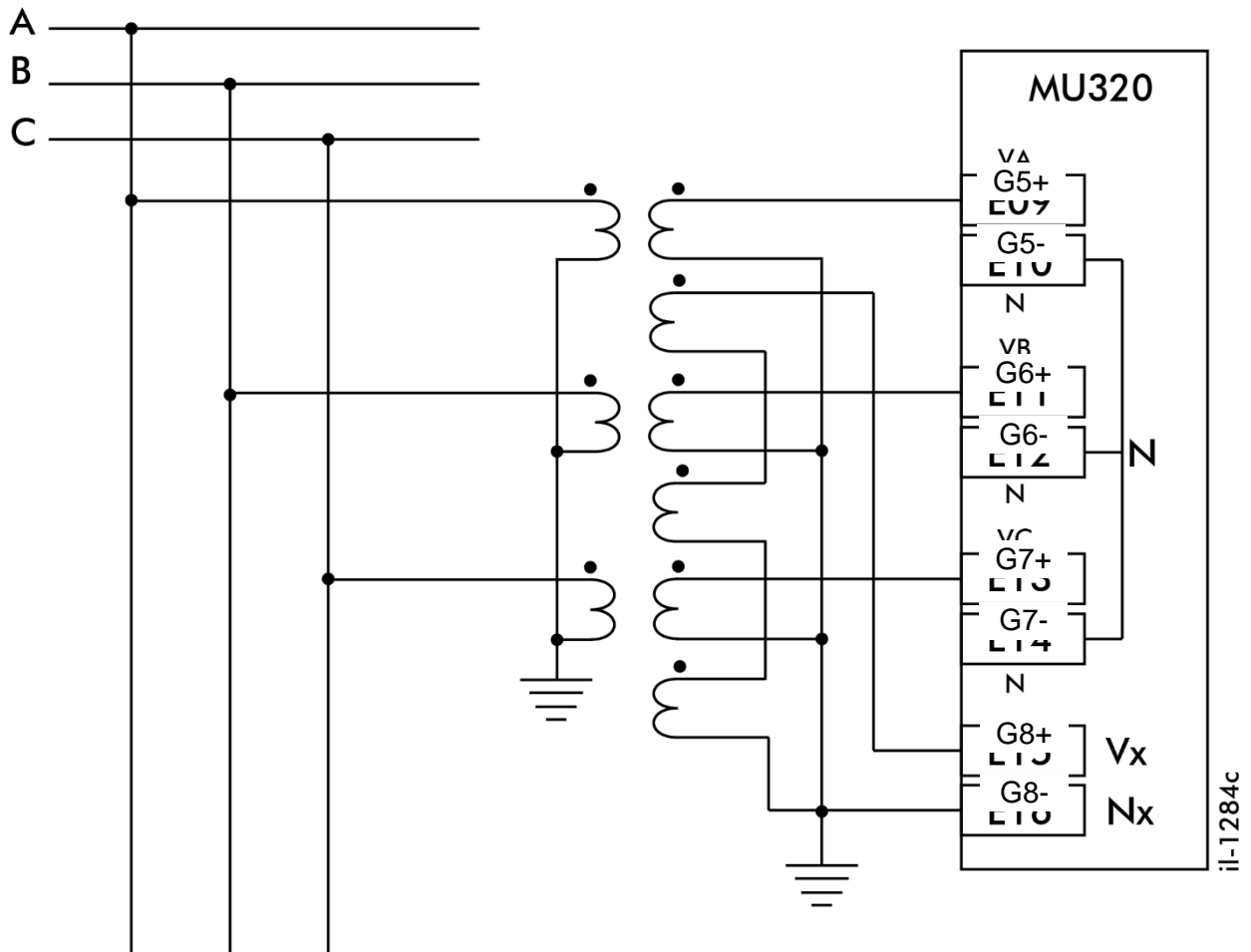

Voltage connection diagram

### 3 Connection Example

In the figure below is shown a typical case for MU320E application example.

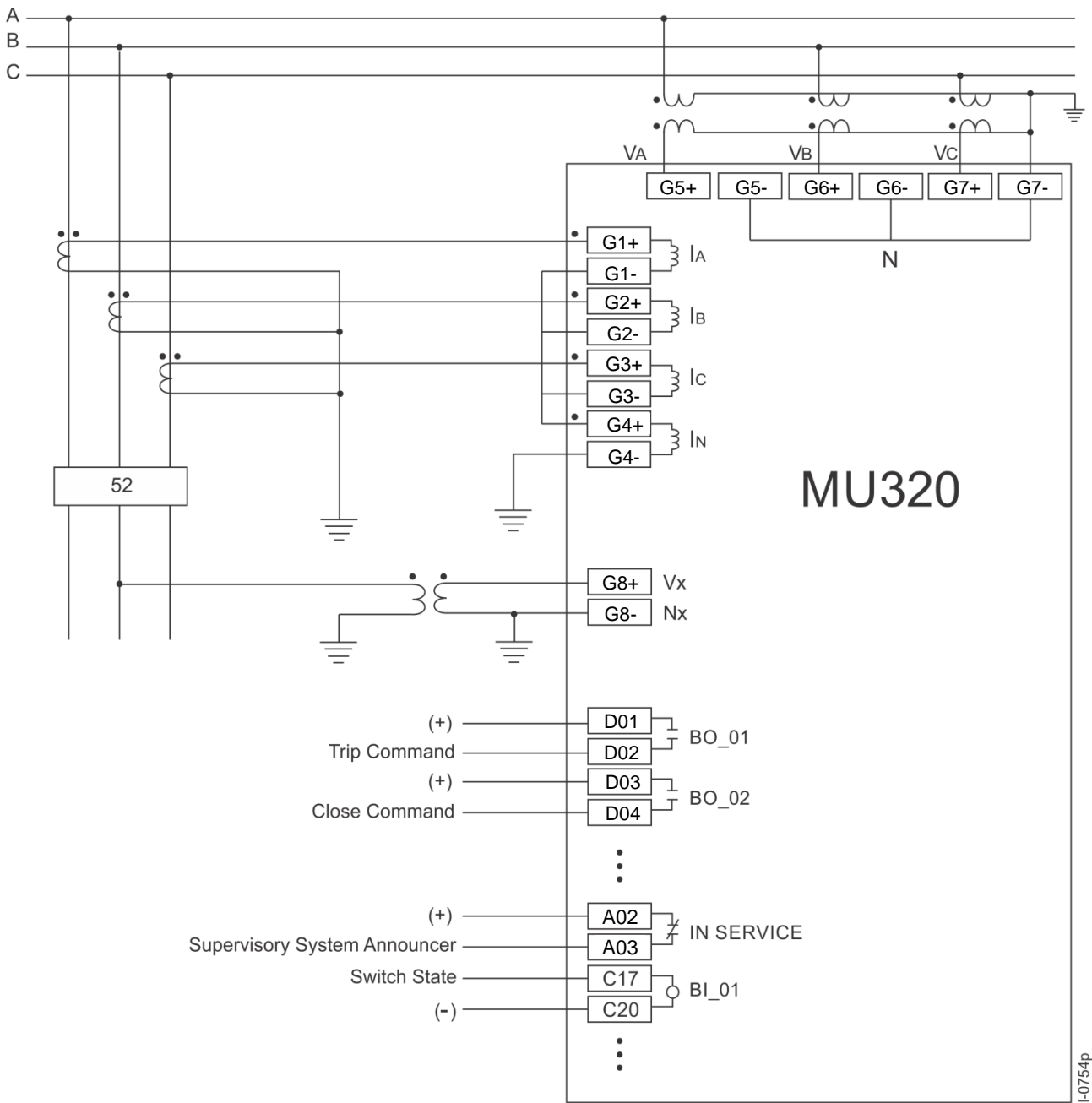

Typical MU320E application example

il-0754p

# MU320E

## Integrated Merging Unit

### Appendix A - PRP

---

#### 1 Parallel Redundancy Protocol (PRP)

The basis of this method is to achieve redundancy is to have two independent paths between two IEDs. The principal advantage of PRP is its interruption-free switchovers, which take no time at all to switch over in failure situations and thus offer the highest possible availability, provided both networks do not fail simultaneously. The sender IED uses two independent network interfaces that transmit the same data at the same time. The redundancy monitoring protocol then makes sure that the recipient uses only the first data packet and discards the other one. If only one packet is received, then the recipient IEDs knows that a failure has occurred on the other path. This principle is employed by the parallel redundancy protocol (PRP), which is described in the IEC 62439-3 standard. PRP uses two independent networks with any topology and is not limited to ring networks.

PRP is implemented in the end devices, while the switches in the networks are standard switches with no knowledge of PRP. An end-device with PRP functionality is called a double attached node for PRP (DAN) and has a connection to each of the two independent networks. A standard device with a single network interface (single attached node, SAN) can be connected directly to one of the two networks. Naturally, in this case, the device will have no redundant path available in the event of a failure. A SAN can alternatively be connected to a redundancy box (RedBox) that connects one or more SANs to both networks. SANs do not need to know anything about PRP, they can be standard devices. In many applications only critical equipment will need a dual network interface and less vital devices can be connected as SANs, with or without a redundancy box.

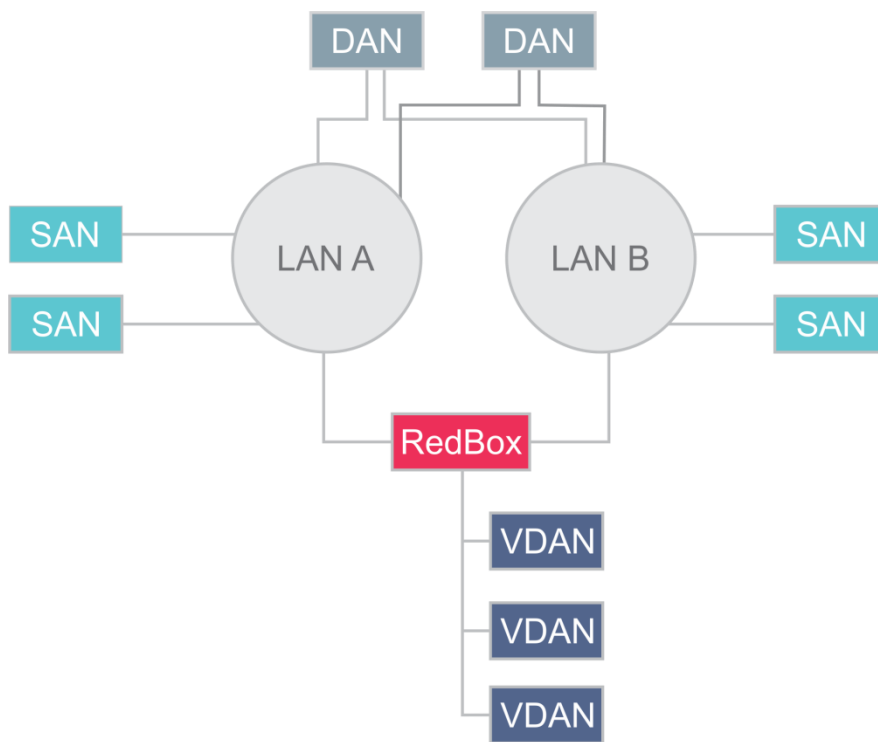

il-1205c

Example of network topology

# MU320E

## Integrated Merging Unit

### Appendix B - Log Codes

#### 1 List of log codes

Log Code	Message
L100	Power Up
L101	PhyHealth: [<status>; cause: <cause>]
L103	Invalid module: [<module_id>; slot: <slot>]
L104	Module not detected: [<module_id> slot: <slot>]
L105	Module not compatible: [<module_id> slot: <slot>]
L106	Internal voltage: [<voltage_reference> value: <value> condition: <status>]
L107	Temperature: [<internal/external> value: <value> °C; condition: <status>]
L108	System frequency: [<nominal_value> Hz]
L200	Ethernet link: [interface: <interface_id> status: <status>]
L201	IP address (station bus): [old: <old> new: <new>]
L202	Gateway (station bus): [old: <old> new: <new>]
L203	Netmask (station bus): [old: <old> new: <new>]
L204	SVCB: [profile: <profile_type>; svid: <svid> status: <status> mode: <test/on>]
L207	MMS connection: [status: <on/off>]
L208	IP address (process bus): [old: <old> new: <new>]
L209	Gateway (process bus): [old: <old> new: <new>]
L210	Netmask (process bus): [old: <old> new: <new>]
L211	Eth0 network settings reset through loopback.
L212	Passwords reset through loopback.
L301	Analog channel not calibrated: [slot: <slot> channel: <channel>]
L302	Manual calibration: [slot: <slot>]
L400	Time synch: [kind: <local/global/none> grandmaster: <grandmaster_id> source: <irigb/ptp/none>]
L402	Synch quality: [<value>]
L500	Procedure to receive configuration: [<ok/erro>]
L501	New configuration: [<ok/erro>]
L502	Initial recording
L503	System boot changed: [image: <factory/application>]
L504	Firmware upgrade: [version: <version> status: <status>]
L505	Key upgrade: [status: <ok/erro>]
L506	ICT requested IED reboot.
L507	ICT requested log cleanup.

L701	Binary input changed its value: [index: <number>, status: <on/off>, name: <label>]
L702	Binary output changed its value: [index: <number>, status: <on/off>, name: <label>]
L703	GOOSE binary input changed its value: [index: <number>, status: <on/off>, name: <label>]
L704	Binary input [name: <label>] changed quality from [validity: <good/invalid/questionable>; quality: <quality>] to [validity: <good/invalid/questionable>; quality: <quality>]
L705	Binary output [name: <label>] changed quality from [validity: <good/invalid/questionable>; quality: <quality>] to [validity: <good/invalid/questionable>; quality: <quality>]
L706	GOOSE input [name: <label>] changed quality from [validity: <good/invalid/questionable>; quality: <quality>] to [validity: <good/invalid/questionable>; quality: <quality>]
L707	Binary input debounce pickup took action: [index: <number>; event: <start/end>; name: <label>]
L708	Binary input debounce dropoff took action: [index: <number>; event: <start/end>; name: <label>]
L709	Binary output debounce pickup took action: [index: <number>; event: <start/end>; name: <label>]
L710	Binary output debounce dropoff took action: [index: <number>; event: <start/end>; name: <label>]
L711	GOOSE input [name: <label>] - [source: <source>] change its value from [state: <on/off>] to [state: <on/off>]
L712	GOOSE input [name: <label>] - [source: <source>] changed quality from [validity: <good/invalid/questionable>; quality: <quality>] to [validity: <good/invalid/questionable>; quality: <quality>]
LC03	Serial <serial_id> settings changed to speed: <value> bps, data bits: <value>, parity: <value>, stop bits: <value>
LL01	ST logic file isn't compatible with IED settings

# MU320E

## Integrated Merging Unit

### Appendix C - RADIUS Configuration

#### 1 RADIUS Configuration

The MU320E receive RADIUS configuration from the ICT via SSH Connection. For this purpose, the user must interact with the device by using ICT's Administrative Tool Menu. With this approach, RADIUS information won't be transmitted in a CID file but via command execution instead. This approach is similar to the one used to update users passwords or to update the Firmware application image running in the MU320.

It is possible to configure up to 5 triads of RADIUS servers.

MU320E will always have the internal User/Password (ADM, CONF, MON). So, in case there's no RADIUS configuration the device will be accessible through them.

The screen used to configure the Radius is presented in below picture. The user can:

- Read the RADIUS configuration;
- Apply changes in the RADIUS configuration;
- Change the IP address, secret and timeout for each RADIUS server;
- Add Radius server (up to 5 Radius Server);
- Remove Radius servers;

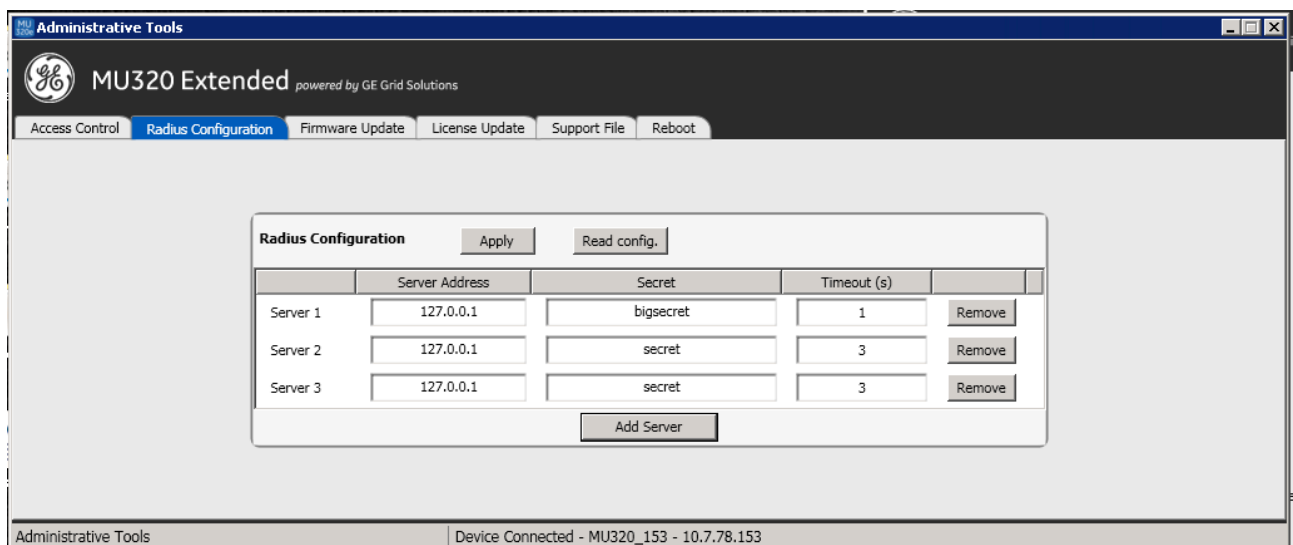

# MU320E

## Integrated Merging Unit

### Appendix D - Assistance

#### 1 For further assistance

For questions or further product support, please contact the GE Vernova support team using:

Region	E-mail	Telephone
Global Contact Centre	<a href="mailto:ga.support@gevernova.com">ga.support@gevernova.com</a>	+44 1785 250070
Central, East Asia, Pacific	<a href="mailto:ga.supportceap@gevernova.com">ga.supportceap@gevernova.com</a>	+61 414 730 964
India	<a href="mailto:ga.supportind@gevernova.com">ga.supportind@gevernova.com</a>	+91 44 2264 8000
Middle East, North Africa, Turkey	<a href="mailto:ga.supportmenat@gevernova.com">ga.supportmenat@gevernova.com</a>	+971 4 375 6950
Europe, Russia, CIS, Sub-Saharan Africa	<a href="mailto:ga.supportercis@gevernova.com">ga.supportercis@gevernova.com</a>	+34 94 485 8854
North America	<a href="mailto:ga.supportnam@gevernova.com">ga.supportnam@gevernova.com</a>	+1 877 605 6777
Latin America	<a href="mailto:ga.supportlam@gevernova.com">ga.supportlam@gevernova.com</a>	+55 48 2108 0300

Website: <https://www.gevernova.com/grid-solutions/multilin/catalog/mu320e.htm>