

**TN1-86400-410PS**  
**Issue 2.0**  
**October 2002**



**TN1Ue**  
**SDH Multiplexer**

**86410 VMAPPER-40 UNIT**

**Technical Overview**  
**and**  
**Reference Manual**

**Copyright © GE Multilin Inc. 2002**

# **TN1Ue**

SDH Multiplexer

Technical Practice and Installation Manual

Copyright © GE Multilin Inc. 2002, All Rights Reserved

The copyright of this document is the property of GE Multilin Inc. This document must not be copied, reprinted or reproduced in any material form, either wholly or in part, without the written consent of GE Multilin Inc.

GE Multilin Inc. reserves the right to make changes and modifications to any part of this document without notice.

GE Multilin Inc. is not responsible for any damages or losses incurred as a result of out-of-date or incorrect information contained in this document.

---

# TABLE OF CONTENTS

<b>SECTION</b>	<b>PAGE</b>
<b>1. INTRODUCTION .....</b>	<b>6</b>
<i>Related Publication and Documentation Support .....</i>	<i>6</i>
<i>Handling and Packing .....</i>	<i>7</i>
<b>2. UNIT OVERVIEW .....</b>	<b>8</b>
<i>Video Transport in a TN1Ue Network .....</i>	<i>8</i>
<i>Unit Structure .....</i>	<i>8</i>
<i>TN1Ue Linear Network .....</i>	<i>9</i>
<i>TN1Ue Ring Network .....</i>	<i>9</i>
<i>Multiple TN1Ue Networks .....</i>	<i>10</i>
<i>VC-3 Path Monitoring .....</i>	<i>10</i>
<i>Bandwidth Assignment .....</i>	<i>10</i>
<b>3. FRONT PANEL FEATURES .....</b>	<b>12</b>
<i>LED Indications .....</i>	<i>12</i>
<i>Push-button (ACK) .....</i>	<i>13</i>
<i>Craft Interface (C.I.) Jack .....</i>	<i>13</i>
<b>4. UNIT DESCRIPTION .....</b>	<b>14</b>
<i>Vport – IN Signal Path .....</i>	<i>15</i>
<i>Vport – OUT Signal Path .....</i>	<i>15</i>
<i>TUG-3 Port – IN Signal Path .....</i>	<i>15</i>
<i>TUG-3 Port – OUT Signal Path .....</i>	<i>15</i>
<i>Microprocessor Operation .....</i>	<i>16</i>
<i>FPGA (U7) Operation .....</i>	<i>16</i>
<i>SRAM (U8) .....</i>	<i>17</i>
<i>SRAM (U9) .....</i>	<i>17</i>
<i>Packets .....</i>	<i>17</i>
<i>Input Packet Processing .....</i>	<i>19</i>
<i>Output Packet Processing .....</i>	<i>21</i>

---

<b>SECTION</b>	<b>PAGE</b>
<b>5. INSTALLATION .....</b>	<b>23</b>
<i>Preinstallation.....</i>	<i>23</i>
<i>Linear Network .....</i>	<i>23</i>
<i>Ring Network .....</i>	<i>23</i>
<i>Cascading VMapper-40 Units .....</i>	<i>24</i>
<i>TUG-3 Port Connection.....</i>	<i>24</i>
<i>Multiple TN1Ue Networks .....</i>	<i>25</i>
<i>Shelf Position .....</i>	<i>25</i>
<i>Installation .....</i>	<i>25</i>
<i>Paddleboard Connections.....</i>	<i>27</i>
<i>Paddleboard Installation.....</i>	<i>29</i>
<i>Replacing a VMapper-40 Unit in a System in Service .....</i>	<i>30</i>
<i>Adding VMapper-40 unit to a System in Service .....</i>	<i>31</i>
<i>Adding VMapper-40 unit on an unused TUG-3 Port.....</i>	<i>31</i>
<i>Adding VMapper-40 unit on a TUG-3 Port already connected         to a VMapper-40 unit (cascading) .....</i>	<i>36</i>
<b>6. CONFIGURATION.....</b>	<b>38</b>
<i>Setup .....</i>	<i>42</i>
<i>Monitor .....</i>	<i>43</i>
<b>7. MAINTENANCE and TROUBLESHOOTING ....</b>	<b>45</b>
<i>F1 Help .....</i>	<i>45</i>
<i>Configuration.....</i>	<i>45</i>
<i>Key Fields to Monitor using the TLCl/TNCl program .....</i>	<i>45</i>
<i>VC-3 Path Monitoring.....</i>	<i>45</i>
<i>Troubleshooting .....</i>	<i>46</i>
<i>Dumb Terminal Mode.....</i>	<i>47</i>
<b>8. UNIT PARAMETERS.....</b>	<b>49</b>
<i>TUG-3 Port (Full Duplex).....</i>	<i>49</i>
<i>Vport (Full Duplex) .....</i>	<i>49</i>
<i>Accuracy of Performance Monitors.....</i>	<i>50</i>

---

<b>SECTION</b>	<b>PAGE</b>
<b>9. SPECIFICATIONS .....</b>	<b>51</b>
<i>Physical</i> .....	51
<i>Electrical</i> .....	51
<i>Environmental</i> .....	51
<i>Mechanical</i> .....	52
<i>EMC</i> .....	52
<i>Safety</i> .....	52
<i>Reliability</i> .....	52
<b>10. ORDERING INFORMATION.....</b>	<b>53</b>
<i>Equipment and Option Code List</i> .....	53
<b>APPENDIX A .....</b>	<b>54</b>
<i>List of Figures</i> .....	54
<i>List of Tables</i> .....	54
<b>APPENDIX B .....</b>	<b>55</b>
<i>List of Acronyms</i> .....	55
<i>List of Acronyms (continued)</i> .....	56

## 1. INTRODUCTION

The 86410 VMapper-40 unit is one of the family of units in GE Multilin's TN1Ue digital transport/access system designed specifically for the requirements of the utility (Power, Transportation, Pipelines, Oil & Gas, etc.) industry using optical fibre transmission.

This manual explains how to operate, install and maintain the 86410 VMapper-40 unit. A unit description and block diagram are included as well as detailed description of the unit's operation.

Engineering documentation includes EAS schematics for all unit circuitry.

### ***Related Publication and Documentation Support***

Additional information is provided in the TN1Ue Technical Overview and Reference Manual for system planning and engineering. The user may also find useful information in Technical Practice and Installation Manuals (TPIMs) for other TN1Ue units.

Customer inquiries for information contained in this manual should be directed to TN1Ue Product Line Management. GE Multilin appreciates notification of any possible errors or omissions contained herein.

Shipped with each purchased TN1Ue node is a Node Assignment Drawing (NAD), which provides necessary configuration details for the units and shelf location. Channel, TU and TIFport are some of the assignments that are shown on the NAD.

### ***Handling and Packing***

Equipment with Electrostatic Discharge Sensitive (ESDS) devices or components must be shipped in protective containers and necessary handling precautions observed otherwise all warranties, expressed or implied, will be considered null and void.

The following Electronic Industries Association (EIA) attention label appears on all GE Multilin EAS schematics and should be attached on all containers used for ESDS items to alert personnel that the contents requires special handling.

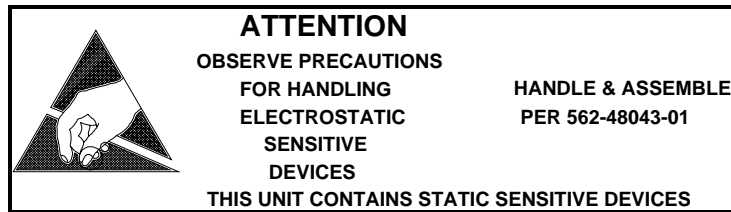

---

## **2. UNIT OVERVIEW**

The 86410 VMapper-40 Unit provides the interface between Video I/O units and STM-1 Aggregate units, and is responsible for mapping the compressed video signal into the bandwidth available for transport over the TN1Ue network. The VMapper-40 unit is a high speed packet switching router with high speed (<1 second) automatic set-up and teardown of virtual circuit paths for maximum bandwidth utilization.

### ***Video Transport in a TN1Ue Network***

To transport video signals using VMapper-40 units, a WAN (wide area network) of 48 Mb/s is created. This TN1Ue network WAN is created by equipping all nodes in the system (requiring video access) with a VMapper-40 unit which connects to VMapper-40 units at the adjacent nodes using a portion (48 Mb/s) of the inter-node SDH payload bandwidth.

The TN1Ue WAN comprises a linear topology with only one path between the video source and destination. This linear topology allows for bandwidth to be reused provided the total bandwidth of 48 Mb/s on any link (between VMapper-40 units) is not exceeded. Note that the 48 Mb/s limit is the sum of all the packet types, not just video.

The intelligent bandwidth allocation allows more bandwidth to be instantly assigned to specific video sources/cameras, allowing incident management, a higher resolution and more frames/sec for what is actually being viewed.

### ***Unit Structure***

The VMapper-40 unit occupies one shelf slot in an 86430-21 Common Equipment Shelf. The VMapper-40 unit uses a two shelf slot wide paddleboard assembly. Either TUG-3#2 or TUG-3#3 or both may be used to transport video signals in a TN1Ue system.

Each VMapper-40 unit has two TUG-3 Ports and four Vports. The TUG-3 Ports on the VMapper-40 unit may connect to the TUG-3 Ports (Y or Z) on the STM-1 Aggregate units or the TUG-3 Ports on collocated VMapper-40 units. At a node, up to four VMapper-40 units may be cascaded thus supporting up to 16 Vports.

Each Vport supports a bandwidth of up to 12.8 Mb/s and connects to a Vport on either a Video I/O unit or a VMapper unit. A video source or a monitor may be connected to a Video I/O unit.

The Vport connections may be electrical or optical. The electrical Vport connections are made on the paddleboard assembly using CAT 5 cable. The optical Vport connections (to remote Video I/O units) are made on the Vport-F unit<sup>1</sup> installed adjacent to the VMapper unit on the same paddleboard.

Front panel LEDs provide indication of received TU-3 signal; far-end received TU-3 signal status, incoming signal status from Video I/O units and the unit's internal status. The unit set-up, status and port activity are reported via the TLCl and TNCl software.

### ***TN1Ue Linear Network***

In a linear network, at a terminal (end) node or add/drop (intermediate) node where up to four Video I/O units are to be accessed, one VMapper-40 unit and one paddleboard assembly are required. At the add/drop (intermediate) node, video traffic may be dropped from either direction. The bandwidth available between adjacent nodes is 48 Mb/s. Bandwidth may be reused provided that the total bandwidth of 48 Mb/s on any link is not exceeded.

### ***TN1Ue Ring Network***

In a ring network, at a node where up to four Video I/O units are to be accessed, one VMapper-40 unit and one paddleboard assembly are required. The VMapper-40 unit at one of the nodes is configured for "Ring Closer" while the VMapper-40 units at all the other nodes are configured for "Normal". This ensures video traffic in the ring is protected against path failure or fibre failure. Note that the "Ring Closer" is not passing video traffic through under normal conditions. The VMapper-40 units use the Path User Channel byte (POH byte F2) to determine if the ring is OK or Broken. Under normal operating conditions the byte 35H (hex) should be seen at IN for both TUG-3 Ports at all VMapper-40 units in the ring. If this is not the case, a break in the ring has occurred and path protection switching is initiated. Note, if ring protection is required then the total bandwidth assigned in the ring should not exceed 48 Mb/s.

---

<sup>1</sup> For more information on 86413-0X Vport-F unit refer to the Vport-F unit TPIM.

**Multiple TN1Ue Networks**

In a TN1Ue system which consists of two or more TN1Ue networks (ring or linear) and the application is to pass video traffic between the TN1Ue networks, at the collocated nodes the Vports on the VMapper-40 units are connected using a crossover cable.

**VC-3 Path Monitoring**

The VMapper-40 unit is capable of end-to-end VC-3 path integrity monitoring. A predetermined, user selectable pattern can be inserted into the VC-3 POH Byte H4 of the outgoing VC-3 without affecting the normal Video traffic. By monitoring the incoming VC-3 POH Byte H4 at the remote site, a valid VC-3 path can be confirmed. This end-to-end VC-3 path monitoring is performed through the supplied TLCl software or through the TNCl software. The VC-3 paths are always terminated at VMapper-40 units.

**Bandwidth Assignment**

The bandwidth assignment principles will be explained using the following network example.

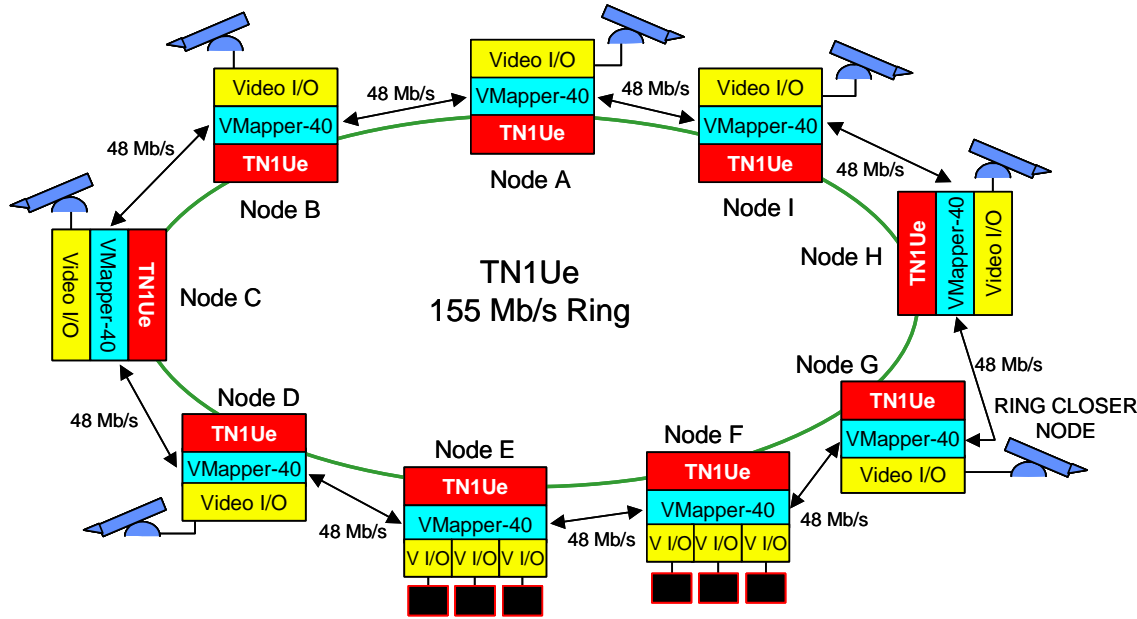

Figure 1: TN1Ue Video WAN

The network is a TN1Ue ring with Node G assigned as the "Ring Closer Node".

The video traffic pattern is as follows.

From Node	To Node	Bandwidth Assigned (Mb/s)
A	E	6
C	E	1
H	F	6
B	F	6
I	E,F	2

**Table 1:** Video Traffic Pattern

The available bandwidth between VMapper-40 units is 48 Mb/s.

Traffic between Node A and Node E

For traffic between Node A and Node E the Through nodes are B, C and D. Since the bandwidth required is 6 Mb/s the unused bandwidths on links A-B, B-C, C-D and D-E is 42 Mb/s. Note that the bandwidth on the links E-F, F-G, G-H, H-I and I-A is still 48 Mb/s.

Traffic between Node C and Node E

The only links affected are links C-D and D-E. Since the video traffic is 1 Mb/s, the unused traffic on these links is 41 Mb/s.

The bandwidth unused between nodes is shown below.

From Node	To Node	Band width (Mb/s)	Through Nodes	Bandwidth Unused between Nodes in Mb/s								
				A-B	B-C	C-D	D-E	E-F	F-G	G-H	H-I	I-A
				48	48	48	48	48	48	48	48	48
A	E	6	B,C,D	42	42	42	42	48	48	48	48	48
C	E	1	D	42	42	41	41	48	48	48	48	48
H	F	6	I,A,B,C,D,E	36	36	35	35	42	48	48	42	42
B	F	6	C,D,E	36	30	29	29	36	48	48	42	42
I	E,F	2	A,B,C,D,E	34	28	27	27	34	48	48	42	40

**Table 2:** Unused Bandwidth Between Nodes

**Note:** If ring protection is required then the total bandwidth assigned in the ring should not exceed 48 Mb/s.

## 3. FRONT PANEL FEATURES

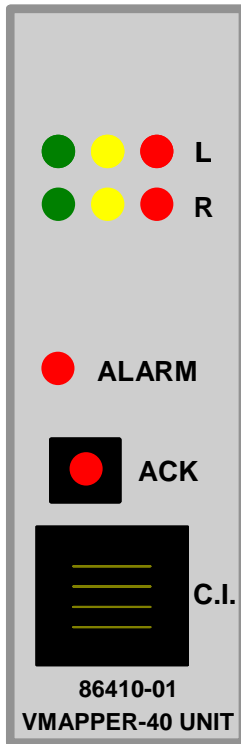

**Figure 2:** Front Panel Layout

### *LED Indications*

#### ***TUG-3 Port Green (L&R)***

A steady green LED indicates that the port is configured as "assigned" and the received TU-3 signal is OK.

#### ***TUG-3 Port Yellow (L&R)***

A steady yellow LED ON indicates that the far-end VMapper-40 unit is not receiving a good TU-3 signal. This is "VC-3 Path Yellow".

Flashing Green, Yellow and Red LEDs indicate a loss of clock from the TUG-3 Port on the STM-1 Aggregate unit or adjacent (cascaded) VMapper-40 unit.

#### ***TUG-3 Port Red (L&R)***

A steady red LED indicates that the TU-3 signal to the VMapper-40 unit is not valid (Path AIS, High B3 BER or Bad Path Signal Label). The Green and Yellow LEDs are usually extinguished when the Red LED is steady on.

### ***ALARM (Red)***

A steady red ALARM LED indicates one of the following:

- Paddleboard is missing
- Lower sub-board is missing
- VCXO voltage is out of range
- Unit temperature is high (>93°C)
- FPGA (Xilinx) did not boot
- Alarm on an assigned Vport (LOS or high BER).

A flashing red ALARM LED is seen when all the above (steady red ALARM LED) conditions are OK and one of the following conditions exists:

- Unit is receiving duplicate "Hello" packets i.e. more than one (of the six ports) are receiving "Hello" packets with the same VNA# address
- Alert on Video I/O unit (e.g. Video LOS)
- Alarm on Video I/O unit (e.g. VCXO control voltage out of range)

### ***Push-button (ACK)***

The first use of the push-button is a LED and microprocessor test. If the VMapper-40 unit is operating normally, holding the front panel pushbutton down causes all the LEDs to light. The main use for this test is to determine that the front panel LEDs are functional and that the microprocessor firmware code is running normally (microprocessor is not locked up).

**Note:** *The microprocessor test does not cause any disruption in traffic.*

The second use of the push-button is to put the unit into a "sleep state". This state is enabled when the VMapper-40 unit is inserted in the shelf with the ACK button pressed. In this condition, the micro ignores all settings on the unit until the TLCI software is run. On establishing the TLCI connection with the unit, the unit is enabled at which point the user can configure the unit to the desired settings. If the unit is inserted with the ACK button pressed and then removed (without establishing TLCI connection to the unit) and inserted normally, all previous settings will remain.

### ***Craft Interface (C.I.) Jack***

The Craft Interface allows a user to connect a PC computer serial (COM) port to the unit. The CI is an RJ-11 connector, which transmits and receives a 9600 b/s RS-232 signal. The supplied DOS-based TLCI (TN1U Local Craft Interface) software allows the user to configure the unit and monitor its status through the CI port.

---

## 4. UNIT DESCRIPTION

The 86410-01 VMapper-40 unit provides the interface between an TUG-3 Port (Y or Z) of an 86432 STM-1 Aggregate unit or a VMapper-40 unit and up to four Vports (four Video I/O units). It uses one TUG-3 of the STM-1 signal.

The unit occupies one shelf slot in a TN1Ue equipment shelf.

The unit has the 087-86410-01 main assembly board which houses the microprocessor (U3), the Field Programmable Logic Gate Array (U7), SRAM (U8), SRAM (U9), VCXO (U10 and U11), DC/DC Converter (U1).

The unit performs the following functions:

- Interfacing to the two TUG-3 Port signals;
- Interfacing to the four Vport signals;
- Buffering the incoming packets from all the six ports of the unit;
- Routing the incoming packets to the correct destination ports;
- Automatic set-up and teardown of packet routing switches;
- Storage of the VNA# table plus the "to-do" lists for each of six output ports and micro;
- Monitoring of the temperature sensor;
- Control of the front panel LEDs and monitoring of the ACK push-button;
- Reporting the unit status and responding to configuration requests from the Craft Interface or NMS;
- Providing visibility of Video I/O unit alarms.

The Vport connections may be electrical or optical. The electrical Vport connections are made on the 86410-7X paddleboard assembly using CAT 5 cable. The optical Vport connections are made on the Vport-F unit installed immediately to the right of the VMapper unit on the same 86410-75 paddleboard.

A simplified Functional Block Diagram of the unit is included at the end of this section and can be used for reference to follow the signal paths; however, the user should refer to schematics EAS-86410-M1 for complete circuit details.

The description of the signal paths is with reference to one of the four Vports, namely Vport #1. Also, the description refers to an electrical Vport connection.

### ***Vport – IN Signal Path***

The Vport DATA IN signal is received on the RJ45 paddleboard and passed through the coupling transformer (T2) and backplane connector J1(C15) to the main assembly board 087-86410-01. The incoming data is monitored for Code Violations (BER) and Low Level. The incoming data must be synchronous. The Vport signal format comprises a framing pattern, followed by eight 25-byte packets, ending with a check bit for error monitoring, per 125  $\mu$ s frame.

### ***Vport – OUT Signal Path***

The packets from U7 are fed to the paddleboard assembly via backplane connector J1(B15) where they are passed through the coupling transformer (T2) and outputted on the RJ45 connector as DATA OUT.

### ***TUG-3 Port – IN Signal Path***

The signal is received on the TUG-3 Port and through the balun transformers sent to the FPGA (U7). U7 terminates the VC-3 POH. The POH bytes supported are:

- J1 is set to 56 HEX and is the Path Trace byte (displayed as V);
- C2 is set for 01 HEX, for the generic "equipped – non-specific" Path Signal Label;
- B3 (BIP-8 byte) is set according to the specified algorithm for detecting VC-3 Path Code Violations;
- G1 is 00 except for far-end VC-3 path failure;
- H4 is used as the Test Byte for VC-3 Path confirmation;
- F2 is set to 35 HEX for monitoring the integrity of Ring systems.

### ***TUG-3 Port – OUT Signal Path***

The signal is outputted through the balun transformers to the TUG-3 Port connector on the top of the unit. The TUG-3 Port connection comprises a XMT and RCV pair of balanced 10 line bi-directional buses (40 wires total). The buses are balanced for EMI and RFI immunity.

### ***Microprocessor Operation***

U3, the HC16 microprocessor, is the CPU for the VMapper-40 unit. For memory the micro uses the 128 kbytes static RAM (U5), the 256 kbytes Flash EEROM (U6). The CPU provides the following:

- Communication with the user through the Craft Interface port;
- Control of all front panel LEDs and monitoring of the ACK push-button switch;
- Monitoring of the unit temperature sensor LM34 (U4) and reporting local unit temperature;
- Configuration of the FPGA U7;
- Monitoring data from the FPGA;
- Communication of the unit status and alarm information to the STM-1 Aggregate unit for the Network Management System (TNCl);
- Processing the configuration requests from TLCl and TNCl.

The 32.768 kHz crystal Y1 forms an oscillator with the micro, which multiplies it for an internal 16.78 MHz CPU clock.

### ***FPGA (U7) Operation***

The VMapper-40 unit uses a Xilinx Field Programmable Gate Array (FPGA) U7 to:

- Sample and drive the TUG-3 Port interface and Vports;
- Facilitate the NMS communications;
- Implement a Phase Locked Loop circuit in conjunction with an external Voltage-Controlled Crystal Oscillator (U11) and multiplier (U10) to synchronize the on-board 16.2 MHz clock (provided by VCXO U11) to the TUG-3 Port clock.
- Use 64.8 MHz clock to over-sample the 16.2 MHz input Vports and recover incoming data;
- Perform packet processing functions.

U7 also terminates the NMS information and passes the incoming packets.

**SRAM (U8)**

The VMapper-40 unit uses a 128k x 8 high speed SRAM U8 to:

- Buffer incoming packets from all six ports of the unit

**SRAM (U9)**

The VMapper-40 unit uses a 64k x 16 high speed SRAM U9 for

- The 8192 entry VNA# table, seven 4096 entry "to-do" lists for each of the six output ports, plus a "to-do" list for the unit's micro.

**Packets**

All data on the Video WAN is encoded in 25 byte packets. The first three bits of the packet's first byte identify the type of packet while the remaining five bits of the first packet and the eight bits of the second byte are used to form the 13-bit Packet Header Address (PHA). Thus there are total of 8192 addresses available. The highest 511 addresses (m1 to m511) are assigned to VMapper units, 6143 addresses (1 to 6143) are assigned to Video I/O units, and the ones in the middle are either unused or used for different packet routing options (see Video I/O Unit TPIM for more information).

There are six different types of packets and their functions are listed below.

Packet Type	Header Bytes	Description	Function
Link	011+ VNA#	Regularly broadcast by each unit, and are not passed on.	Helps each unit to learn the VNA# of its neighbours (unless the unit is to right of a Ring Closer unit) and identifying any dead links.
Hello	001 + VNA#	Regularly broadcast by each unit, and passed through every other unit, to reach all other units in the network.	Each unit keeps a table so that it knows the entry port of each VNA#.

Wanted	010 + VNA#	<p>Broadcast by each unit wanting to receive video from another unit.</p> <ul style="list-style-type: none"> <li>- Each VMapper-40 unit receiving a WANTED packet looks at its table to see if it has an entry for the VNA#; if so, it passes the packet to the recorded port (producing the VNA# "Hellos").</li> <li>- The unit routing this packet puts an entry in the table to flag the port producing the packet. If more than one monitor wants the same source, there will be more than one flagged port in the table for that particular VNA#.</li> <li>- Remove the flags if the "WANTED" packets cease.</li> <li>- The third byte in the "WANTED" packet indicates the spare capacity of the path by having each VMapper-40 unit compare the byte with its port's idle rate.</li> </ul>	<p>"WANTED" packets find their way to the other unit.</p> <ul style="list-style-type: none"> <li>- quick teardown of obsolete paths to maintain the full bandwidth for the active paths.</li> <li>- allows the source unit to know whether it can accommodate a request for more bandwidth.</li> </ul>
Payload	10X + VNA#	<p>Broadcast by each Video I/O unit transmitting data.</p> <ul style="list-style-type: none"> <li>- Each VMapper-40 unit receiving a "Payload" packet looks at its table to</li> </ul>	<p>Payload packets find their way directly to (all) the destination(s).</p>

		see if it has any flagged ports for the VNA#; if so, it passes the packet to the recorded port(s) producing the VNA# "WANTED".	
Message	110 + VNA#	Used for messages exchanged between the units' microprocessors. Also, all data-port and Contact I/O data is transported in "Message" packets (see Video I/O Unit TPIM for more information).  Each VMapper-40 unit receiving a "Message" packet looks at its table to see if it has an entry for the VNA#; if so, it passes the packet to the recorded port (producing the VNA# "Hellos").	Message packets find their way directly to the destination unit.
Idle	000+13 zeros	Each VMapper-40 and Video I/O unit transmits "idle" packets as required.	To maintain continuous packets on all ports.

**Table 3:** Packet Types

### Input Packet Processing

As each packet is written to its buffer area (the Packet Start Address – PSA is noted), the packet's 3-bit header is used to control which of the actions to invoke.

#### 001 "HELLO" PACKETS

The packet's VNA# is used as an index to the unit's VNA table. For each VNA, the table has four fields. They are:

- A 1-bit HFLAG - set by each incoming "HELLO" packet;
- A 3-bit HPORT field – to encode the source port for "HELLO" packets;
- A 6-bit WPORT field – 1 bit for each of the unit's ports;
- A 6-bit WFLAG field – 1 bit for each of the unit's ports.

Each Video I/O unit or VMapper-40 unit outputs a "HELLO" packet at least once per minute (<once per second for normal video). The HFLAG is set by each incoming "HELLO" packet. A polling routine checks and clears the HFLAG bit for each VNA# once per minute; if the routine finds an entry with the bit already cleared, it deletes the remaining fields. This ensures that the VNA table is kept reasonably current.

The HPORT field is updated with the port originating the "HELLO" packets. If this changes, and it happens repetitively, this VNA# is not unique in the Video Network System and the "Duplicate-Hello" alert is activated.

For each of the 6 ports, if both the WPORT and WFLAG fields are set, the WFLAG field's bit is cleared (this starts the "teardown" of an obsolete path to a monitor). If the WPORT field is set and the WFLAG field bit is already cleared, then the WPORT field bit is cleared (this completes the "teardown" of an obsolete path).

The packet's PSA is placed on the "to-do" list of either 5 or 6 of the unit's 6 output ports (hairpinning is suppressed on the TUG-3 Ports, and on any Vports connected to VMapper-40 units).

#### 010 "WANTED" PACKETS

The packet's VNA# is used as an index to the unit's VNA table.

The corresponding WPORT and WFLAG fields' bit for the packet source port are set.

The packet's PSA is placed on the "to-do" list for the port whose bit is set in the HPORT field.

#### 10x "PAYLOAD" PACKETS

The packet's VNA# is used as an index to the unit's VNA table.

The packet's PSA is placed on the "to-do" list for the ports whose bits are set in the WPORT field.

#### 110 "MESSAGE" PACKETS

The packet's VNA# is used as an index to the unit's VNA table.

If the VNA# matches that of the unit, the packet's PSA is placed on the "to-do" list for the micro; otherwise, it is put on the "to-do" list for the HPORT field port.

#### 011 "LINK" PACKETS

The packet's PSA is placed on the "todo" list of the unit's micro.

000 "IDLE" PACKETS

No action is taken. (These incoming packets go nowhere).

**Output Packet Processing**

For each of the 6 output ports, when a new packet is required, the oldest waiting entry on its "to-do" list is used.

If the "to-do" list is empty, an idle packet is sent.

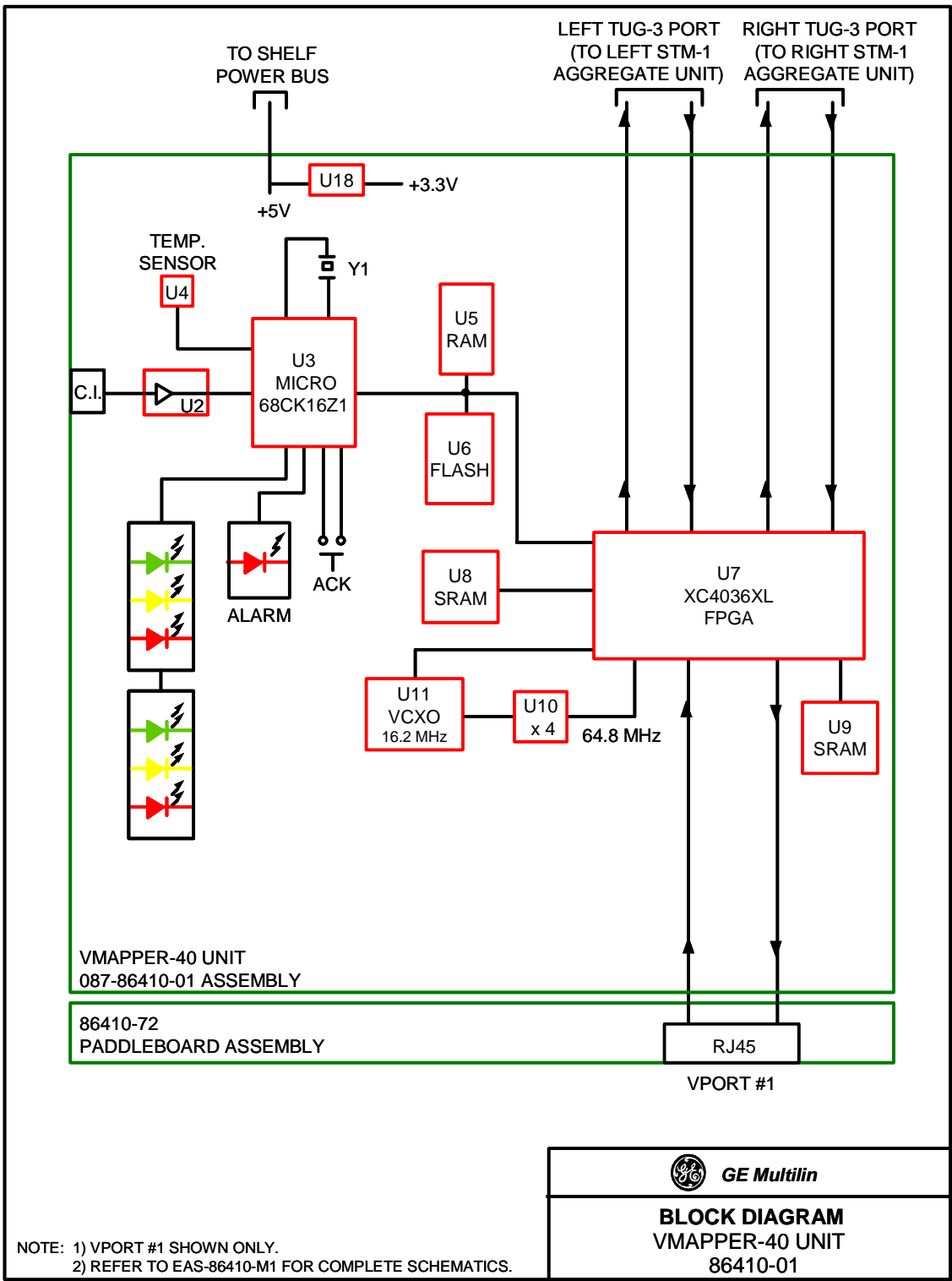

Figure 3: VMapper-40 Unit Block Diagram

---

## 5. INSTALLATION

The following section provides information for installing an 86410 VMapper-40 unit. The unit is shipped from the factory configured as per the Node Assignment Drawing for the purchased system. All spare units or loose units are shipped with factory default settings in memory.

### CAUTION

**The VMapper-40 unit has ESDS components and therefore standard static protection precautions should be observed when handling, packing or shipping the unit.**

#### *Preinstallation*

Visually check the unit for damage. Ensure that screws are firmly tightened and in place. Keep the shipping containers and packing materials for future use. If a unit is damaged, file a claim with the shipping agent or local GE Multilin representative.

#### *Linear Network*

At a node in a linear network, one VMapper-40 unit and one paddleboard assembly are required. At the terminal node the left TUG-3 Port on the VMapper-40 unit is connected to the TUG-3 Port (Y or Z) on the STM-1 Aggregate unit. At the add/drop node the left and right TUG-3 Ports on the VMapper-40 unit are connected to the TUG-3 Ports (Y or Z) on the left and right STM-1 Aggregate units respectively.

#### *Ring Network*

At a ring node, one VMapper-40 unit and one paddleboard assembly are required. The left and right TUG-3 Ports on the VMapper-40 unit are connected to the TUG-3 Ports (Y or Z) on the left and right STM-1 Aggregate units respectively. One of the VMapper-40 units is configured for "Ring Closer" while all other VMapper-40 units are configured as "Normal".

**Cascading VMapper-40 Units**

Some applications may require more than four Video I/O units at a single node. VMapper-40 units may be cascaded to support up to 16 Video I/O units at a single node (Figure 4).

On the first VMapper-40 unit the right TUG-3 Port is connected to the TUG-3 Port on the right STM-1 Aggregate unit while the left TUG-3 Port on the first VMapper-40 unit is connected to the right TUG-3 Port on the second VMapper-40 unit. The left TUG-3 Port on the second VMapper-40 unit is connected to the right TUG-3 Port on the third VMapper-40 unit. The left TUG-3 Port on the third VMapper-40 unit is connected to the TUG-3 Port on the left STM-1 Aggregate unit.

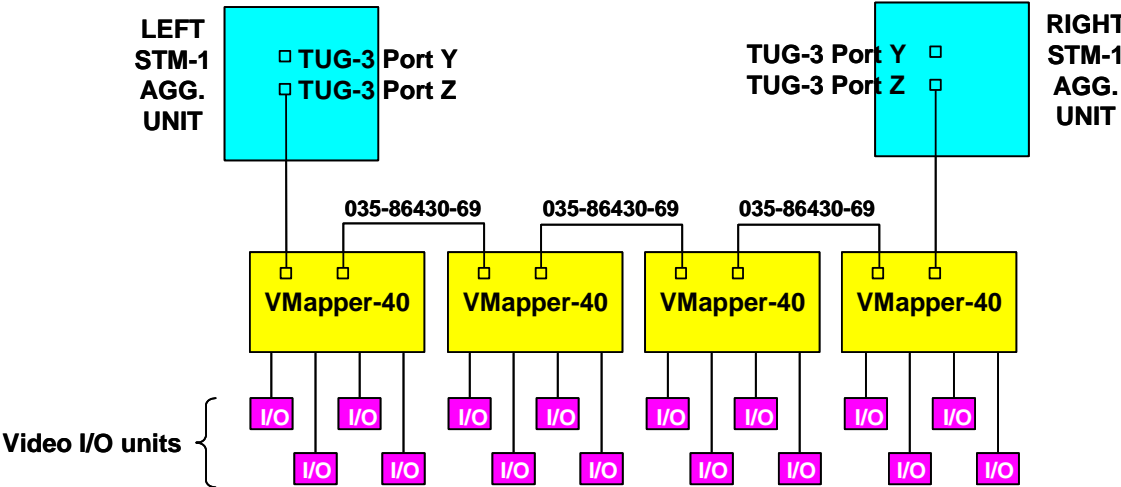

**Figure 4: Cascading VMapper-40 Units**

**TUG-3 Port Connection**

The TUG-3 Port is a 40-pin connector located on the top plate of the unit and is used to connect the VMapper-40 unit to the TUG-3 Port Y or TUG-3 Port Z on the STM-1 Aggregate unit.

For establishing TUG-3 Port connections, special 40-wire ribbon cables are used. For more information on these cables, refer to the *TUG-3 Cables* in the *Cables and Accessories* section of the TN1Ue Equipment Shelf TPIM.

**Note:** The STM-1 Aggregate unit's TUG-3 Ports connected to VMapper-40 units must be configured for TU-3 DROP.

**Note:** At all nodes passing the VMapper-40 traffic through (with no VMapper-40 units connected to the given Video WAN), the respective TUG-3 Ports on the STM-1 Aggregate units must be set for TU-3 THRU mode.

### **Multiple TN1Ue Networks**

In a TN1Ue system which consists of two or more TN1Ue networks (ring or linear) and video traffic is to be passed between the TN1Ue networks, at the collocated nodes the appropriate Vports on the VMapper units are connected using a crossover cable. This creates a "Vport-tie connection".

**Note:** It is important, when extending the Video WAN through Multiple TN1Ue networks, to ensure there is only one video path between any two VMapper units in the system.

### **Shelf Position**

The 86410-01 VMapper-40 unit can be installed in slots 2 to 10 of an 86430-21 Common Equipment Shelf. It must be aligned with the J1 slot of an 86410-7X paddleboard (Figure 6) which may be installed in slots 2 to 11 of the Common Equipment Shelf backplane.

If one or two optical Vports are required, an 86413-0X Vport-F unit is installed immediately to the right of the VMapper units on the same paddleboard (see Figure 6). If not equipped with a Vport-F unit (i.e. no optical Vports required), this paddleboard slot is equipped with the blank unit. Note that if more than two (three or four) optical Vports are required, a separate VMapper unit must be used.

Figure 5 shows a typical rack layout for a ring-configured system as it appears on a NAD.

### **Installation**

Before installing the VMapper-40 units in the shelf, verify that 087-86430-90 CBUS jumper (used to extend the CBUS on the Shelf back plane) is not installed underneath nor on either side of the VMapper-40 paddleboard.

The VMapper-40 unit can be inserted and removed from the shelf with shelf power applied; however, certain precautions should be taken before inserting or removing the unit from a system in service. Refer to the Sections *Replacing a VMapper-40 Unit in a System in Service* and *Adding VMapper-40 Unit to a System in Service* before taking any action.

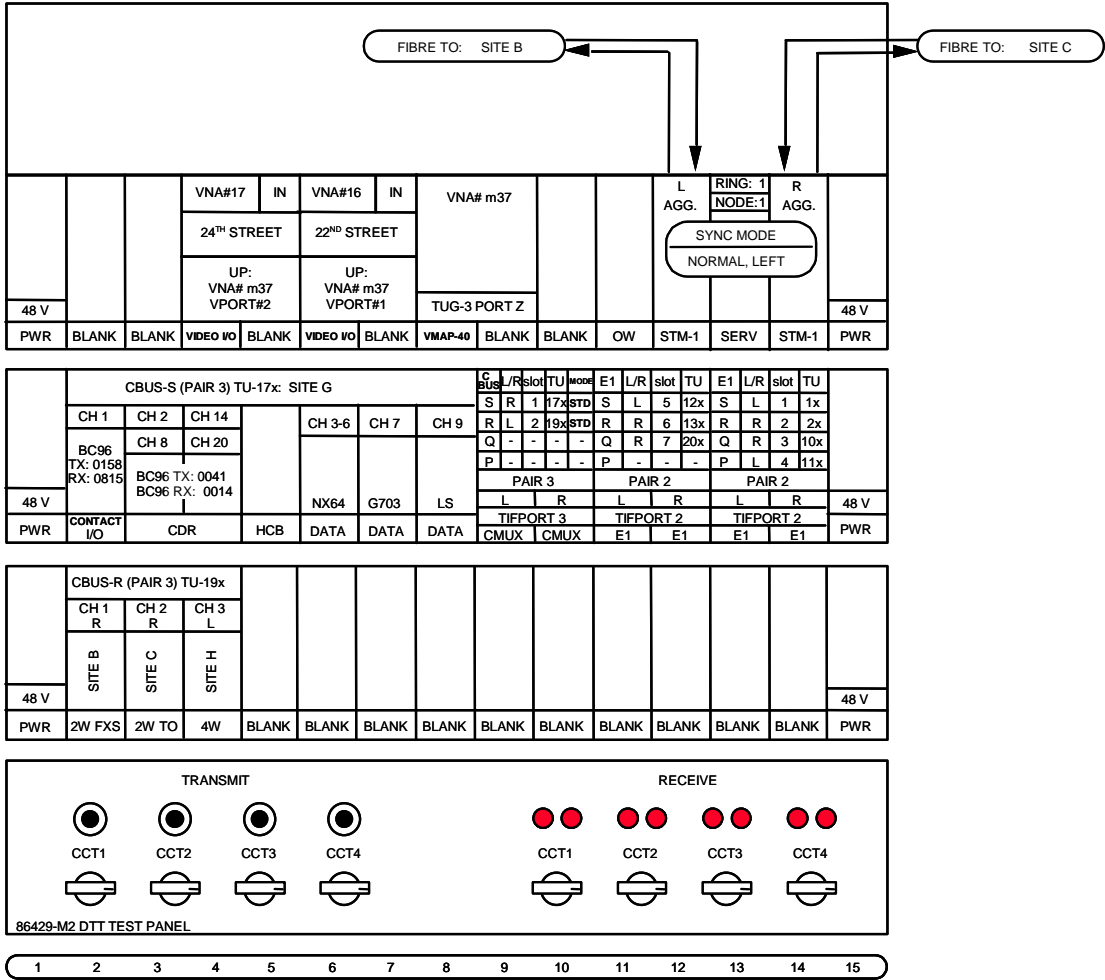

Figure 5: Typical Rack Layout

**Paddleboard Connections**

Each VMapper-40 unit requires one 86410-7X Paddleboard. The Paddleboard provides Vport connections to the unit.

There are two paddleboard options offered with a VMapper-40 unit (both are two-shelf-slots wide): 86410-72 (Figure 6a) and 86410-75 (Figure 6b). Which of the two paddleboards is used depends on whether any optical Vports are needed.

The 86410-72 paddleboard provides four electrical Vport connectors (RJ45). This paddleboard is used when no optical Vports off the VMapper-40 unit are required. The Vports are labelled "DOWN". Each Vport provides a data link to a Vport labelled "UP" on a Video I/O unit paddleboard or to a Vport labelled "DOWN" on another VMapper unit paddleboard (for Vport-Tie applications).

The 86410-75 paddleboard allows a maximum of two optical Vport connections to be established off the VMapper-40 unit (with a Vport-F unit installed to the right of the VMapper unit). The paddleboard also provides four RJ45 connectors (labelled "DOWN") for electrical Vport connections.

**Note:** When an 86410-75 paddleboard is used for electrical Vport and Vport-Tie connections to the paddleboards using previous-generation Vport drivers (86410-72, 86411-72 and 86412-73) the user may experience occasional Vport BER. This is due to different Vport driver chips used in two paddleboard generations.

Number of optical Vports required	Paddleboard	Unit installed in the paddleboard's slot J2
NONE	86410-72	Blank
ONE (Vport #1)	86410-75	86413-01 or 86413-02 <sup>1)</sup> with Jumper J2 set for Disabled
TWO (Vports #1, 2)	86410-75	86413-02 with Jumper J2 set for Enabled
THREE OR FOUR	Use separate (cascaded) VMapper-40 units installed on separate 86410-75 paddleboards.	

<sup>1)</sup> May be a preferred solution if Vport #2 is expected to be converted to an optical one in the future.

**Table 4: Paddleboard Usage**

When connecting a VMapper-40 unit to a Video I/O unit electrically, the Vport "DOWN" on the VMapper-40 unit is connected to the Vport "UP" on the Video I/O unit using a straight-through CAT 5 cable. For this purpose, cables 035-86400-24 (30 cm), 035-86400-25 (60 cm), 035-86400-26 (90 cm) and 035-86400-22 (1.5 m) are used. The cable selection depends on the distance between the VMapper-40 unit and respective Video I/O unit.

To connect the Vports on two VMapper units (Vport-Tie connection), a Vport "DOWN" on one VMapper unit is connected to a Vport "DOWN" on the other VMapper unit using a crossover CAT 5 cable. For this purpose, cables 035-86400-27 (1 m), 035-86400-28 (3 m), 035-86400-29 (6 m) and 035-86400-21 (10 m) are used. The cable selection depends on the distance between the two VMapper units.

Either paddleboard option consists of the bottom paddleboard, top paddleboard (which itself consists of two sub-boards, each housing two Vports) and EMC cover. The Paddleboard Assembly is considered one part (86410-7X) even though it comprises multiple sub-assemblies.

**Note:** *The EMC cover must be installed to prevent excessive electromagnetic emissions.*

Figure 6 details the paddleboard connections.

<p style="text-align: center;"><b>WARNING</b></p> <p style="text-align: center;"><b>For correct operation, the CBUS Jumper 087-86430-90 <u>must not</u> be installed underneath nor on either side of the VMapper-40 unit paddleboard.</b></p>
--

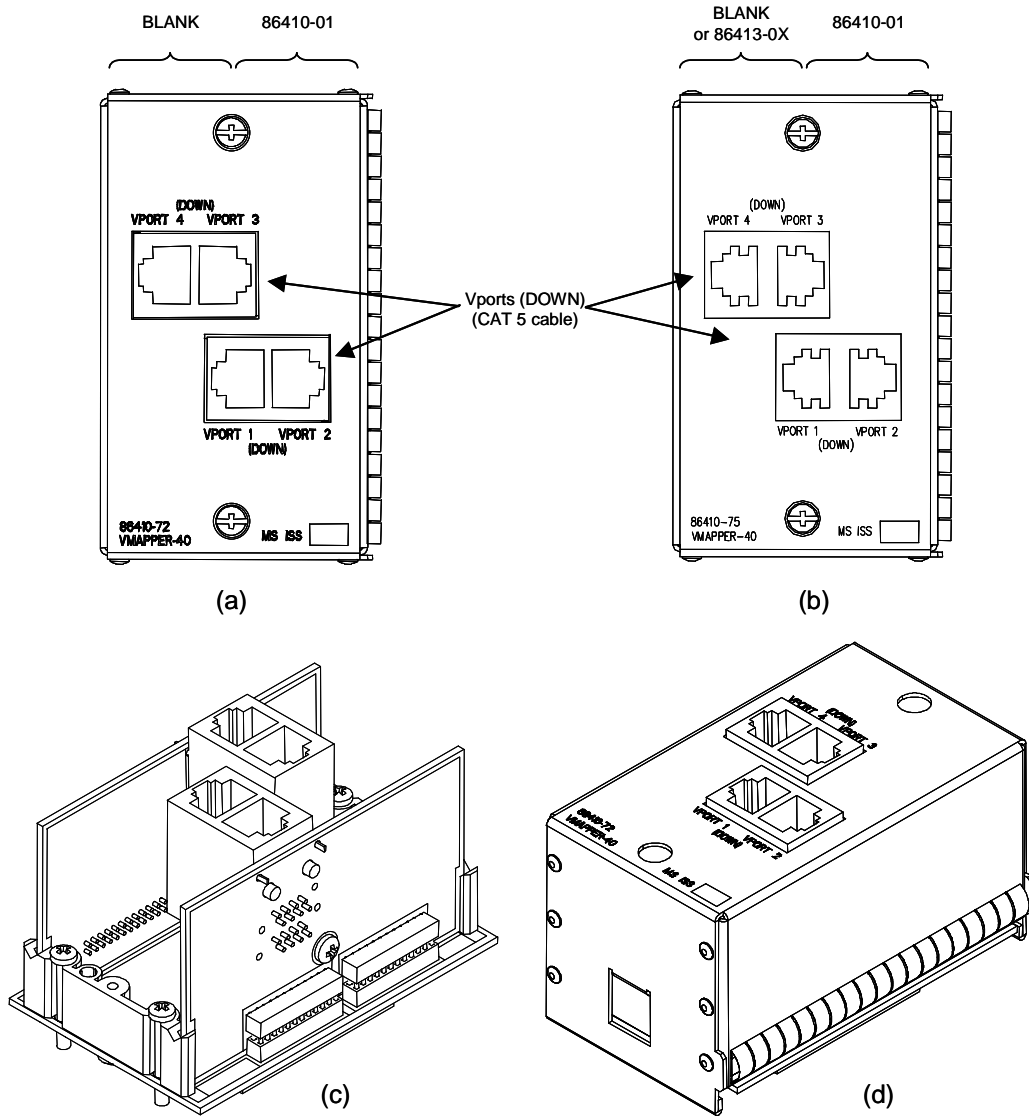

**Figure 6:** VMapper-40 Paddleboard Assemblies: (a) 86410-72; (b) 86410-75; (c) 3-D View without EMC Cover; (d) 3-D View with EMC Cover (86410-72)

### Paddleboard Installation

1. Separate bottom and top paddleboards. Do not detach EMC cover from top paddleboard.
2. Insert bottom paddleboard into designated slot position ensuring that rear connectors are fully mated. Ensure correct orientation of bottom paddleboard prior to insertion.

3. Secure bottom paddleboard in position using fixing screws provided.
4. Insert top paddleboard (with attached EMC Cover) onto bottom paddleboard using guide grooves on bottom paddleboard to aid connector alignment. Ensure that connector pins are correctly aligned and fully mated. Ensure correct orientation of top paddleboard prior to insertion.
5. Secure top paddleboard and EMC Cover in position using integral retaining screws accessible through upper and lower apertures on EMC Cover.

### ***Replacing a VMapper-40 Unit in a System in Service***

#### Removing a VMapper-40 Unit

1. Use the TLCI program to display the unit configuration. Write down the settings in all configurable fields so that the replacement unit can later be configured the same.
2. Use the red tab on the face plate of the unit to ease the unit from the shelf and disconnect the TUG-3 Port cable(s) from the unit's top plate.

#### Inserting a Replacement VMapper-40 Unit

1. Connect the TUG-3 Port cable(s) to the TUG-3 Port on the unit's top plate.

**WARNING**

**Inserting the VMapper-40 unit into a working position without ACK button pressed may cause traffic disruption in an in-service system!**

**WARNING**

**Do not use the red tab to force the unit into the shelf as this could result in damage to the red tab.**

2. With the ACK button pressed, gently insert the VMapper-40 unit into the shelf by pressing the front panel. (Ensure the red tab is not preventing the unit from insertion.) When inserted with ACK button pressed, the VMapper-40 unit is in the "Sleep State" with the interrupts enabled; any earlier programming on this VMapper-40 unit is disabled at this point. (Note, the unit need not be inserted with the ACK button pressed if the user is sure that the unit is programmed correctly, i.e. same as the previously removed unit.)
3. Use the TLCI program to program the unit parameters in the same way as they were programmed on the replaced unit.

### ***Adding VMapper-40 unit to a System in Service***

#### **Adding VMapper-40 unit on an unused TUG-3 Port**

When a VMapper-40 unit is to be added on and unused TUG-3 Port, there are two possible cases:

- a) VMapper-40 unit is to be installed in the main Common Equipment Shelf (the one that houses STM-1 Aggregate units)
- b) VMapper-40 unit is to be installed in a different Common Equipment Shelf

#### **VMapper-40 unit being installed in Common Equipment Shelf housing STM-1 Aggregate units**

1. Ensure that at least one new 035-86430-70 cable is available. (Refer to the Equipment Shelf TPIM for more information on this cable.)
2. Install the VMapper-40 unit paddleboard on the shelf backplane in one of the slot pairs listed before in this section (refer to *Shelf Position* and *Paddleboard Installation*). Ensure that the CBUS Jumper (087-86430-90) is not installed in the backplane underneath nor on either side of the paddleboard.
3. Use the TLCI program to “Force-AIS” in both upstream and downstream directions on the STM-1 Aggregate unit which is to be connected to the VMapper-40 unit.
4. Remove the fibre-optic patch cords from the STM-1 Aggregate unit.
5. Place protective covers on the fibre-optic patch cords and on the STM-1 Aggregate unit optical connectors.
6. Use the red tab on the face plate of the unit to ease the STM-1 Aggregate unit from the shelf and disconnect the 035-86430-70 cable from the TUG-3 Port which is to be connected to the VMapper-40 unit (the cable connected to the other TUG-3 port, if in place, should not be removed).
7. Connect one end of the new 035-86430-70 cable to the STM-1 Aggregate unit's TUG-3 Port.

**WARNING**

**Do not use the red tab to force the unit into the shelf as this could result in damage to the red tab.**

8. Gently insert the STM-1 Aggregate unit into the shelf. Seat the unit into the shelf by pressing the front panel. (Ensure the red tab is not preventing the unit from insertion.) Ensure the ACK button is not pressed during the unit insertion.
9. Remove the protective covers from the STM-1 Aggregate unit optical connectors and the fibre-optic patch cords.
10. Return the fibre-optic patch cords (RCV fibre first, then XMT fibre) to the STM-1 Aggregate unit. Ensure that the notch on the FCPC connector aligns with the groove on the connector on the STM-1 Aggregate unit (towards the front).
11. Connect the other end of the new 035-86430-70 cable to the respective VMapper-40 unit port.
12. If a VMapper-40 unit is installed at a ring node or add/drop node in a linear network, connect the loose end of the 035-86430-70 cable that was disconnected from the STM-1 Aggregate unit in Step 6 to the other TUG-3 Port on the VMapper-40 unit.

**WARNING**

**Inserting the VMapper-40 unit into a working position without ACK button pressed may cause traffic disruption in an in-service system!**

13. Gently insert the VMapper-40 unit into the appropriate shelf slot with the ACK button pressed. Seat the unit into the shelf by pressing the front panel. (Ensure the red tab is not preventing the unit from insertion.)
14. Refer to the Node Assignment Drawing and configure the unit for:
  - Frame Mode: SDH
  - Unique VNA#. The number must be in the range 1-511.
  - Type: "Normal" or "Ring Closer". Note, only one VMapper-40 unit in a ring should be configured as "Ring Closer".
  - Sync: Normal
15. If any Vport-F units are to be installed with the VMapper unit, do the following:
  - Ensure that the shelf slot where the Vport unit is to be inserted has been properly selected and the proper paddleboard is installed on the backplane (see Table 4 and Figure 6).
  - (For 86413-02 unit only) Set Jumper 2 for the unit's desired mode of operation (see Table 2 in Vport-F unit TPIM).
  - Insert the Vport-F unit into the shelf and establish fibre connections on the top of the unit.

16. Configure the used TUG-3 Ports and Vports for "Assigned".
17. Configure the mode of operation of the STM-1 Aggregate unit's TUG-3 Port connected to the VMapper-40 unit to "TU-3 DROP".
18. On the VMapper-40 unit expect to see only green LED(s) ON. If not, see troubleshooting section.

After two minutes (or longer):

- Check that the reported number of "alive" Video I/O and VMapper units corresponds to the actual number of these units in the Video WAN.
- Check that the reported VNA numbers on all assigned ports are as expected.

**Note:** After major system changes/reconfigurations (or whenever necessary), use both TLCl software and dumb terminal commands Z1, Z7A and Z7B at each and every VMapper unit in the system to confirm that the system is functioning according to the network designer's intention (for more information on dumb terminal commands refer to Section 7).

#### VMapper-40 unit being installed in Common Equipment Shelf **NOT** housing STM-1 Aggregate units

In the following procedure, the Common Equipment Shelf housing STM-1 Aggregate units is referred to as Shelf #1 while the Common Equipment Shelf where the VMapper-40 unit is being installed is referred to as Shelf #2.

1. Ensure that a pair of 035-86400-11 cables and one 035-86400-10 or 035-86400-09 cable are available for each VMapper-40 unit's TUG-3 Port to be connected (at a terminal node in a linear network only one TUG-3 Port is connected). (Refer to the Equipment Shelf TPIM for more information on these cables.)
2. Install the VMapper-40 unit paddleboard on the shelf backplane in one of the slot pairs listed before in this section (refer to *Shelf Position* and *Paddleboard Installation*). Ensure that the CBUS Jumper (087-86430-90) is *not* installed in the backplane underneath nor on either side of the paddleboard.
3. Use the TLCl program to "Force-AIS" in both upstream and downstream directions on the STM-1 Aggregate unit which is to be connected to the VMapper-40 unit.

4. Remove the fibre-optic patch cords from the STM-1 Aggregate unit.
5. Place protective covers on the fibre-optic patch cords and on the STM-1 Aggregate unit optical connectors.
6. Use the red tab on the face plate of the unit to ease the STM-1 Aggregate unit from the shelf and disconnect the 035-86430-70 cable from the TUG-3 Port which is to be connected to the VMapper-40 unit (the cable connected to the other TUG-3 port, if in place, should not be removed).
7. At the rear of the shelf #1 chassis remove the blanking plate from the aperture associated with the TUG-3 Port to be connected to the VMapper-40 unit. Mount the bulkhead connector end of the 035-86400-11 cable to the aperture (from inside) using the screw-lock kit provided with the cable. Mount the other end of the cable to the selected STM-1 Aggregate unit's TUG-3 Port.

**WARNING**

**Do not use the red tab to force the unit into the shelf as this could result in damage to the red tab.**

8. Gently insert the STM-1 Aggregate unit into the shelf. Seat the unit into the shelf by pressing the front panel. (Ensure the red tab is not preventing the unit from insertion.) Ensure the ACK button is not pressed during the unit insertion.
9. Remove the protective covers from the STM-1 Aggregate unit optical connectors and the fibre-optic patch cords.
10. Return the fibre-optic patch cords (RCV fibre first, then XMT fibre) to the STM-1 Aggregate unit. Ensure that the notch on the FCPC connector aligns with the groove on the connector on the STM-1 Aggregate unit (towards the front).
11. At the rear of the shelf #2 chassis remove the blanking plate from the aperture associated with the TUG-3 Port to be connected to the VMapper-40 unit. Mount the bulkhead connector end of the 035-86400-11 cable to the aperture (from inside). Mount the other end of the cable to the VMapper-40 unit's TUG-3 port (located on the unit's top plate). Interconnect the two bulkhead connectors mounted in steps 7 and 11 with 035-86400-10 (0.6m) or 035-86400-09 (1.2m) cable. Note that with 035-86400-09 cable, the operating temperature range for the node is reduced to 0 to +55° C.)
12. If a VMapper-40 unit is installed at a ring node or add/drop node in a linear network, repeat Steps 3-11 for the other STM-1 Aggregate unit. (The same TUG-3 Port on the other STM-1 Aggregate unit needs to be connected to the other TUG-3 Port on the VMapper-40 unit).

**WARNING**

**Inserting the VMapper-40 unit into a working position without ACK button pressed may cause traffic disruption in an in-service system!**

13. Gently insert the VMapper-40 unit into the appropriate shelf slot with the ACK button pressed. Seat the unit into the shelf by pressing the front panel. (Ensure the red tab is not preventing the unit from insertion.)
14. Refer to the Node Assignment Drawing and configure the unit for:
  - Frame Mode: SDH
  - Unique VNA#. The number must be in the range 1-511.
  - Type: "Normal" or "Ring Closer". Note, only one VMapper-40 unit in a ring should be configured as "Ring Closer".
  - Sync: Normal
19. If any Vport-F units are to be installed with the VMapper unit, do the following:
  - Ensure that the shelf slot where the Vport unit is to be inserted has been properly selected and the proper paddleboard is installed on the backplane (see Table 4 and Figure 6).
  - (For 86413-02 unit only) Set Jumper 2 for the unit's desired mode of operation (see Table 2 in Vport-F unit TPIM).
  - Insert the Vport-F unit into the shelf and establish fibre connections on the top of the unit.
15. Configure the used TUG-3 Ports and Vports for "Assigned".
16. Configure the mode of operation of the STM-1 Aggregate unit's TUG-3 Port connected to the TUG-3 unit to "TU-3 DROP".
17. On the VMapper-40 unit expect to see only green LED(s) ON. If not, see troubleshooting section.

After two minutes (or longer):

- Check that the reported number of "alive" Video I/O and VMapper units corresponds to the actual number of these units in the Video WAN.
- Check that the reported VNA numbers on all assigned ports are as expected.

**Note:** After major system changes/reconfigurations (or whenever necessary), use both TLCL software and dumb terminal commands Z1, Z7A and Z7B at each and every VMapper unit in the system to confirm that the system is functioning according to the network designer's intention (for more information on dumb terminal commands refer to Section 7).

---

### **Adding VMapper-40 unit on a TUG-3 Port already connected to a VMapper-40 unit (cascading)**

In the following procedures, the VMapper-40 unit already installed in the shelf will be referred to as VMapper-40 unit #1 while the VMapper-40 unit being installed is referred to as VMapper unit #2. Since the cable used for cascading (035-86430-69) is very short (6.3 cm), the VMapper-40 unit #2 and the associated paddleboard must be installed immediately to the left or immediately to the right of the unit. As the normal engineering practice for equipping the Common Equipment Shelf is to use the slots closer to the STM-1 Aggregate units first, it is assumed that VMapper unit #2 is added to the left of the VMapper unit #1.

1. Ensure that at least two adjacent shelf slots immediately to the left of the VMapper-40 unit #1 are unequipped. Ensure that one 035-86430-69 cable is available. (Refer to the Equipment Shelf TPIM for more information on this cable.)
2. Install a VMapper-40 unit paddleboard on the shelf backplane immediately to the left of the VMapper-40 unit #1. (Refer to *Paddleboard Installation*). Ensure that the CBUS Jumper (087-86430-90) is not installed in the backplane underneath nor on either side of the paddleboard.
3. Use the TLCI program to set the VMapper-40 unit #1's left TUG-3 port to "Unassigned". Disconnect the 035-86430-70 cable from this port. (The other end of the cable should remain connected to the Left STM-1 Aggregate unit.)

#### **WARNING**

**Do not use the red tab to force the unit into the shelf as this could result in damage to the red tab.**

4. Gently insert the VMapper-40 unit #2 into the appropriate shelf slot. Seat the unit into the shelf by pressing the front panel. (Ensure the red tab is not preventing the unit from insertion.)
5. Refer to the Node Assignment Drawing and configure the VMapper 40 unit #2 for:
  - Frame Mode: SDH
  - Unique VNA#. The number must be in the range 1-511.
  - Type: "Normal" or "Ring Closer". Note, only one VMapper-40 unit in a ring should be configured as "Ring Closer".
  - Sync: Normal

6. If any Vport-F units are to be installed with the VMapper unit, do the following:
  - Ensure that the shelf slot where the Vport unit is to be inserted has been properly selected and the proper paddleboard is installed on the backplane (see Table 4 and Figure 6).
  - (For 86413-02 unit only) Set Jumper 2 for the unit's desired mode of operation (see Table 2 in Vport-F unit TPIM).
  - Insert the Vport-F unit into the shelf and establish fibre connections on the top of the unit.
7. Configure the used TUG-3 Ports and Vports for "Assigned".
8. Connect the right TUG-3 Port on the VMapper-40 unit #2 to the left TUG-3 port on the VMapper-40 unit #1 using 035-86430-69 cable. Connect the loose end of the 035-86430-70 cable that was disconnected from the VMapper-40 unit #1 in Step 3 to the left TUG-3 Port on the VMapper-40 unit.
9. Configure the VMapper-40 unit #1's left TUG-3 port back to "Assigned".

After two minutes (or longer):

- Check that the reported number of "alive" Video I/O and VMapper units corresponds to the actual number of these units in the Video WAN (on both VMapper-40 units).
- Check that the reported VNA numbers on all assigned ports are as expected (on both VMapper-40 units).

**Note:** After major system changes/reconfigurations (or whenever necessary), use both TLCL software and dumb terminal commands Z1, Z7A and Z7B at each and every VMapper unit in the system to confirm that the system is functioning according to the network designer's intention (for more information on dumb terminal commands refer to Section 7).

---

## 6. CONFIGURATION

To configure the 86410-01 VMapper-40 unit, connect a PC running the supplied TN1U Local Craft Interface (TLCI) software to the CI jack on the front of the unit. An 84910-05 RJ-11 cable and an 84910-06 (9-pin adapter) or 84910-07 (25-pin adapter) or equivalent are required.

The software displays programmable fields, information about the unit and the unit status. The unit will be shipped with the programmable fields set as per the Node Assignment Drawing (NAD) for the purchased system.

The VMapper-40 unit does not have any hardware adjustable options. All configurations are performed through the supplied TLCI software.

### ***TLCI SCREEN INFORMATION***

The user should refer to Figure 7 (VMapper-40 unit TLCI Screen). An explanation of each field and their function follows.

#### FRAME MODE

The VMapper-40 unit can be configured for either the SDH mode or SONET mode. For operation in TN1Ue system, SDH mode must be selected.

**Note:** *A change in the configuration of the unit from one mode to another will cause the unit to reboot.*

**Note:** *Although the FRAME MODE field is to be set first during the unit initial setup procedure, it is the last configurable field in the JCI screen.*

#### PORT (Not Adjustable)

The VMapper-40 unit has six available ports for connection. The TUG-3 Ports on the top of the unit connect to the corresponding TUG-3 Ports on an STM-1 Aggregate unit or the TUG-3 Ports on another VMapper-40 unit (cascading). Each of the four Vports on the paddleboard assembly may connect to the Vport on a Video I/O unit or the Vport on a VMapper unit.

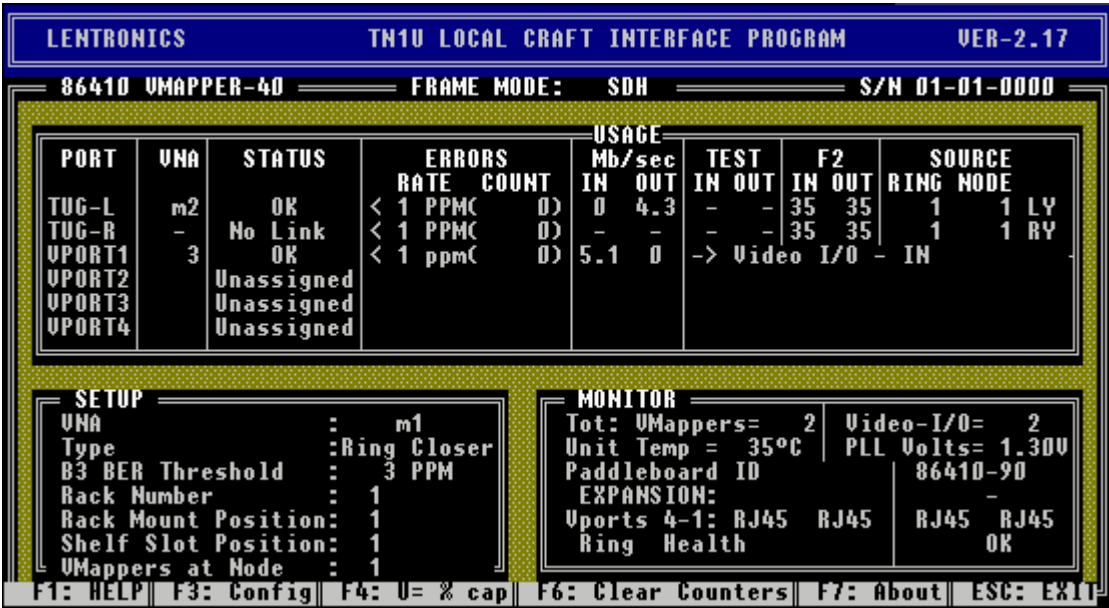

Figure 7: VMapper-40 Unit TLCI Screen

Function Key	Description
F1	On-Line Help – provides definition and explanation of some of the fields used in this screen.
F3	Used to enter the configuration mode. The first programmable field is highlighted. The up and down arrow keys may be used to go through different fields. F5 is used to edit the fields. The left and right arrow keys may be used to display different options.
F4	Toggles the mode of the Usage field (shows bandwidth usage in Mb/s or in %).
F6	Resets the unit error counters to zero for the six ports on the VMapper-40 unit.
F7	Displays the unit serial number and firmware version.

Table 5: Function Keys in TLCI Screen

VNA (Not Adjustable)

Each VMapper unit and Video I/O unit has its own unique Video Network Address (VNA). This field displays the VNA number of

the unit connected to this port. A VNA address for a VMapper unit is in the range 1 – 511 and is always displayed with the letter "m" preceding the number. A VNA address for a Video I/O unit is in the range 1 – 6143.

### STATUS

May be set to Assigned (port is used) or Unassigned (port is unused) for each of the six ports on the VMapper-40 unit.

Note, at a ring node or add/drop node in a linear system, both TUG-3 Ports are connected to the respective STM-1 Aggregate units and assigned. At a terminal node, right port is not connected and not assigned (unless cascaded to another VMapper-40 unit).

During normal operation, this field indicates the status of each assigned port on the VMapper-40 unit.

Following are the possible display values for TUG-3 Ports (shown in priority order):

- Clock fail – TUG-3 Port not connected to STM-1 Aggregate unit;
- AIS – Path AIS detected;
- B3 BER – B3 error rate exceeds threshold;
- J1 mismatch – the J1 trace bytes  $\neq$  ASCII "V";
- No link – Normal and OK for the right TUG-3 Port of a VMapper-40 unit configured as Ring Closer unit, and left TUG-3 Port of the VMapper-40 unit to the right of the Ring Closer unit in the video network;
- Yellow – Far-end VMapper-40 unit is in alarm;
- Dupl-Hello – VNA#s are not unique in the video system.

Following are the possible display values for Vports (shown in priority order):

- LOS – no signal detected at this Vport;
- BER – an excessive bit error rate at this Vport;
- Dupl-Hello – VNA#s are not unique in the video system;
- ALARM – Alarm state of the unit connected to the Vport;
- ALERT – Alert state of the unit connected to the Vport.

### ERRORS (Not Adjustable)

Displays the current bit error rate and cumulative count of errors detected for the assigned ports on the VMapper-40 unit.

<F6> "Clear Counters" resets internal counters to zero for all six ports.

### USAGE (Not Adjustable)

Displays the current usage of the bandwidth for each assigned port, for both IN and OUT directions. The bandwidth usage is displayed either in Mb/s or as a percentage of the port's capacity. F4 key toggles the mode. Ideally the network loading should be set so that the bandwidth usage for any port is below 90%.

### TEST

The Position Indicator byte (H4) can be used to carry a specific pattern for test purposes to confirm end-to-end VC-3 path integrity. At the near end unit, a predetermined user-selected value (two hexadecimal digits) is displayed in the "IN" column while at the far-end VMapper-40 unit the received hex byte is displayed in the "OUT" column. The user selectable patterns are hexadecimal '11' through 'EE'. Note that using this feature does not affect normal video traffic.

### F2 (Not Adjustable)

The F2 byte in the path overhead is used to determine the health of the ring. Normally the byte of '35' hex should be seen at the "IN" for both TUG-3 Ports. If this is not the case, a break in the ring has occurred and a path protection switch is initiated.

### SOURCE (Not Adjustable)

The TUG-3 Port can be connected to an STM-1 Aggregate unit or an adjacent (cascaded) VMapper-40 unit. For STM-1 Aggregate unit connections, the ring number and node number for the node that the STM-1 Aggregate unit belongs to is displayed. Also, the side (L/R) and the port (Y/Z) is displayed for the TUG-3 Port connection to the STM-1 Aggregate unit.

For a cascade connection (TUG-3 Port of one VMapper-40 unit to an adjacent VMapper-40 unit TUG-3 Port), "VM40" is displayed. Ring and Node information is only displayed at the end VMapper-40 units (the ones whose one port is connected to the STM-1 Aggregate units directly).

## **Setup**

### VNA

Each VMapper unit has its own unique Video Network Address (VNA). A VNA address for a VMapper unit is in the range 1 – 511 and is always displayed with the letter "m" preceding the number.

### TYPE

In a ring configuration, one and only one VMapper-40 unit must be configured for "Ring Closer". All other units in the ring must be configured as "Normal". The VMapper-40 unit configured for "Ring Closer" is responsible for initiating the path protection switch if a break in the ring is detected. Note that under normal conditions (no ring failures) the Ring Closer node is not supporting any traffic on its Right TUG-3 Port.

In a linear configuration, all VMapper-40 units are configured for "Normal".

### B3 BER THRESHOLD

VC-3 Path BER threshold setting. An alarm condition is reported if the threshold setting is exceeded.

### RACK NUMBER (use is optional)

Identifies rack or cabinet in which the unit is located. This information may be utilized on the NMS (Network Management System).

### RACK MOUNT POSITION (use is optional)

Identifies location of shelf in which the unit is located. This information may be utilized on the NMS.

### SHELF SLOT POSITION (use is optional)

Identifies slot position within the shelf (1 through 15) in which the unit is located. This information may be utilized on the NMS.

### VMAPPERS AT NODE

Can be set for 1, 2, 3 or 4. Identifies the number of cascaded VMapper-40 units (including this one) at the node.

INTERNAL SYNC (Hidden when set to Normal)

In TN1Ue video applications this field is set to Normal. In Video LAN applications (not requiring SDH links), one VMapper-40 unit in each Video LAN is configured to Internal.

**Monitor**

TOTAL VMAPPERS (Not Adjustable)

Displays the total number of VMapper units visible to this unit. In normal operating systems this number corresponds to the total number of VMapper units in the TN1Ue system. It is normal for changes in the system to be updated after three to four minutes.

TOTAL VIDEO-I/O (Not Adjustable)

Displays the total number of Video I/O units visible to this unit. In normal operating systems this number corresponds to the total number of Video I/O units in the TN1Ue system. It is normal for changes in the system to be updated after three to four minutes.

UNIT TEMP (Not Adjustable)

Displays the average temperature within the VMapper-40 unit with a  $\pm 2^{\circ}$  C accuracy. Normally the reading is about  $15^{\circ}$  C above ambient.

PLL VOLTS (Not Adjustable)

The VMapper-40 unit uses a Phase Lock Loop (PLL) to synchronize its rate to that of the SDH system. The PLL voltage controls a VCXO to obtain a synchronous clock. The PLL voltage is normally  $1.2 \pm 0.4$  V. The VMapper-40 unit will alarm when this voltage is  $<0.8$ V and  $>2.5$ V.

PADDLEBOARD ID (Not Adjustable)

The VMapper-40 unit can identify the type of the paddleboard it is connected to. The type of paddleboard is detected by means of a resistor divider feeding the units A-D converter on its main board.

When used with 86410-72 paddleboard, the paddleboard code number 86410-90 is displayed. When used with 86410-75 paddleboard, the code number 86410-96 is displayed.

**Note:** 86410-90 and 86410-96 are generic paddleboard options with same functionality as 86410-72 and 86410-75 respectively but not used in TN1Ue systems.

EXPANSION (Not Adjustable)

Indicates the type of the Vport-F unit installed on this paddleboard (if applicable) and the number of optical Vports enabled on the unit. Possible readings are:

- '—' Vport-F unit is NOT installed.
- '86413-01' A single-port Vport-F unit is installed in the respective slot.
- '86413-02-1' A dual-port Vport-F unit is installed in the respective slot and its second Vport is disabled.
- '86413-02-2' A dual-port Vport-F unit is installed in the respective slot and its second Vport is enabled.

VPOR TS 4-1 (Not Adjustable)

Indicates the type of Vport connection for each of the four Vports. Displays RJ45 for an electrical Vport or FIBRE for an optical one.

RING HEALTH

Ring Health uses the F2 byte to determine if the ring is OK or broken.

## 7. MAINTENANCE and TROUBLESHOOTING

### *F1 Help*

The "F1" key is a useful tool for explaining the capabilities and options of both programmable fields and display fields of the unit. The user selects "F1" from the TLCI screen and then chooses the topic he/she wishes information on.

### *Configuration*

The 86410-01 VMapper-40 unit must be correctly configured as per the Node Assignment Drawing. All software adjustable fields are detailed in the Configuration Section of this manual. The user must ensure that all external connections to the paddleboard are correct.

### *Key Fields to Monitor using the TLCI/TNCI program*

Field	Typical Range	Cause for Concern
PLL Voltage	1.2 ± 0.4 V.	<0.8V and >2.0V.
Temperature	15° C above ambient.	Excessive high temperature.
Total VMappers	Must correspond to the number of all VMapper units in the system. Displayed count includes this unit.	If different, use Dumb Terminal (Z7A and Z7) commands to identify the cause of problem.
Total Video I/O	Must correspond to the number of all Video I/O units in the system per designer's intent.	If different, use Dumb Terminal (Z7A) commands to identify the cause of problem.

**Table 6:** Key Fields to Monitor

### *VC-3 Path Monitoring*

The VMapper-40 unit is capable of end-to-end VC-3 path integrity monitoring. The H4 byte in the VC-3 POH can be set to one user selectable value. By

monitoring the incoming H4 byte content at the far end, a validity of the VC-3 path can be confirmed. This end-to-end VC-3 path monitoring is performed through the TLCI or TNCI software.

### **Troubleshooting**

If an 86410-01 VMapper-40 unit is suspected of being defective, substitute it for a known-good 86410-01 unit and if the unit functions properly, return the original to GE Multilin for repair or replacement. Ensure that the substitute unit is configured correctly. For unit removal and insertion, refer to the procedures *Replacing a VMapper-40 Unit in a System in Service* and *Adding a VMapper-40 Unit to a System in Service* in the Installation section.

The following table is intended to provide the user with possible solutions to problems that may be encountered during normal unit operation.

<b>Symptom</b>	<b>Probable Cause / Solution</b>
L or R red LED steady on	<ul style="list-style-type: none"> <li>- Ensure that STM-1 Aggregate units are not in alarm.</li> <li>- Verify that Add and Drop configuration is correct per the Node Assignment Drawing.               <ul style="list-style-type: none"> <li>- Verify that VMapper-40 unit TUG-3 Ports are physically connected to proper TUG-3 Ports on the STM-1 Aggregate units.</li> <li>- Verify that the TUG-3 Port field in the STM-1 Aggregate unit is configured for TU-3 DROP.</li> <li>- Verify that the used TUG-3 Ports and Vports are "Assigned" in the VMapper-40 units.</li> </ul> </li> <li>- Check the alarm reported in the Status field of the TLCI screen and do the following:               <ul style="list-style-type: none"> <li>- "AIS", "BAD BER" – Check all hops on VC-3 path;</li> <li>- "BAD LABEL" – Check whether the far-end unit is a VMapper-40 unit.</li> <li>- Verify the correct configuration of other VMapper units in the system.</li> </ul> </li> <li>- Ensure that VC-3 path is correct. Use POH Byte H4 to verify VC-3 end-to-end path integrity.</li> </ul>
R or L yellow LED steady on	<ul style="list-style-type: none"> <li>- Indicates that the far-end VMapper-40 unit is receiving an abnormal TU-3 signal. The respective far-end unit's TUG-3 Port Red LED is steady on.</li> </ul>
All TUG-3 Port LEDs flashing	<ul style="list-style-type: none"> <li>- Indicates a loss of clock from the STM-1 Aggregate unit. Check the TUG-3 Port connection.</li> </ul>

ALARM LED steady on	<ul style="list-style-type: none"> <li>- Indicates one of the following. Check the alarm reported in the TLCI screen.           <ul style="list-style-type: none"> <li>- Paddleboard is missing - Verify that the main paddleboard is present.</li> <li>- Paddleboard's lower sub-board is missing</li> <li>- VCXO control voltage is out of range. The VCXO voltage should be in the range <math>1.2V \pm 0.4V</math>.</li> <li>- Unit temperature is excessive - an alarm is generated if the unit temperature exceeds 93°C.</li> <li>- FPGA (Xilinx) did not boot - Replace the unit</li> <li>- Vport is configured for "assigned" but is receiving a bad signal (either LOW-LEVEL or HIGH BER). Verify that the cable connecting the Vport on the Vmapper-40 unit to the Video I/O unit or another Vmapper-40 unit is OK. Use another (unused) Vport on the VMapper-40 unit and the Video I/O unit to confirm that the Vports on the respective units are not defective.</li> </ul> </li> </ul>
ALARM LED flashing	<ul style="list-style-type: none"> <li>- Occurs when the conditions under "ALARM LED Steady ON" are OK and one of the following conditions exist:           <ul style="list-style-type: none"> <li>- Video I/O unit is in alarm. See Video-I/O unit troubleshooting.</li> <li>- Unit is receiving duplicate "Hello" packets – at least two (of the six) ports are receiving "Hello" packets with the same VNA# address. Verify that each VMapper-40 unit or Video I/O unit is assigned a unique VNA# address; in a ring system verify that one VMapper-40 unit is configured for "Ring Closer". Use Z7A and Z7B commands (see Dumb Terminal Mode).</li> </ul> </li> </ul>

**Table 7:** Troubleshooting Table

### Dumb Terminal Mode

The standard TLCI program provides the necessary information to the user to locate problems; however, the user may use commands in the Dumb Terminal Mode to get more information on the status of unit or the operation of the system. To enter the Dumb Terminal mode and communicate directly with the microprocessor at the DOS Prompt run Access program.

To establish a Dumb Terminal session

1. Connect the TLCI cable to the craft interface port on the VMapper-40 unit
2. At the DOS Prompt type `cd TLCI` (or enter the directory in which Access program resides)
3. Type `ACCESS`
4. Enter <return>
5. Receive a confirmation that a connection is established
6. Enter <return>
7. Receive the prompt `J>OK`

The following table lists some of the commands used in Access program.

<b>Command</b>	<b>Displays</b>
Z1	The units VNA# assignment, the TUG-3 Port assignments, the TUG-3 Port neighbour's VNA#s (unless the right port of a Ring Closer unit get FFFF), if link packets are not being received, if the unit is configured as a Ring Closer unit and its status, the TUG-3 Ports' received signal status (BER, AIS), the test bytes, number of alive units detected.
Z2	The Vport assignments, if an assigned and functioning port has its "hairpinning" disabled, the Vport received signals status (BER and LOW LEVEL), the Video I/O unit in alarm.
Z3	Five used ADC signal levels and if in alarm.
Z4	Incoming and outgoing idle rates on all six ports.
Z6	Last two messages received by the unit.
Z7	The VNA# table for the first 128 Video I/O units and the first 64 VMapper-40 units. See interpretation of the Z7 command for more information.
Z7A	The VNA#s with non-zero entries (scans all 8192 entries in the table).
Z7B	The "Hello" source port, and all the "Wanted" exit ports, for the specified VNA#.

**Table 8:** Dumb Terminal Commands

Interpretation of the Z7 Command

The Z7 command displays the VNA# table for the first 128 Video I/O units, and the first 64 VMapper-40 units (excluding the local unit). This display is updated once a minute. A non-zero entry means that the unit is receiving "Hello" packets for that VNA#.

---

## 8. UNIT PARAMETERS

### *TUG-3 Port (Full Duplex)*

Connector:	40-conductor fine pitch IDC connector
Data:	20 XMT signals and 20 RCV signals Byte-wide data at 6.48 Mbyte/sec
Packet Rate:	240k packets/sec
Packet Size:	25 bytes (4 $\mu$ s)
Packet Bit Rate:	48 Mb/s
Input Packet Buffer:	1024 packets (4.27ms)
Output Packet "TODO" List Buffer:	4096 packets (17.1ms)

### *Vport (Full Duplex)*

Connector:	RJ45 Connector
Cable type:	CAT 5 (8 conductor)
Cable Max. Length:	50' or 15m
Line Rate:	16.2 MHz
Format:	Serial Bits
Coding Format:	5B:4B
Data Bit Rate:	12.96 Mb/s
Packet Bit Rate:	12.8 Mb/s
Frame Rate:	8 kHz

Packet Rate:	64k packet/sec
Packet Size:	25 bytes
Input Packet Buffer:	256 packets (4ms)
Output Packet "TODO" List Buffer:	4096 packets (64ms)
VNA# Table	8192 entries

***Accuracy of Performance Monitors***

B3 Error Rate:	$\pm 20\%$
Vport Error Rate:	$\pm 20\%$
PLL Voltage Monitor:	$\pm 5\%$

---

## 9. SPECIFICATIONS

### *Physical*

The VMapper-40 unit is housed in a standard TN1Ue common equipment shelf mechanics and occupies one shelf slot with the following dimensions:

- 1) Height: 89 mm (3.5 inches)
- 2) Width: 29 mm (1.135 inches)
- 3) Depth: 203 mm (8 inches)
- 4) Weight: 150 grams (5 oz)

### *Electrical*

The input power requirements for the VMapper-40 unit are:

- 1) Voltage: 5.2 VDC  $\pm$ 5%
- 2) Current: 600 mA (max)
- 3) Power Consumption: 3.0 W (max), 2.5 W (typical)

This voltage is supplied from the 86430-21 Common Equipment Shelf.

### *Environmental*

- 1) Temperature:
  - Guaranteed Performance: -10 to +60°C (+14 to +140°F)
  - Storage: -40 to +70°C (-40 to +158°F)
- 2) Relative Humidity: 5 to 95% @ 40°C, non-condensing, 10 days
- 3) Shipping Altitude: 15,000 meters (50,000 feet)

### ***Mechanical***

- 1) Vibration: per MIL-STD 810E and  
Bellcore TR-NWT-000063 (GR-63-CORE)
- 2) Bench Handling: per TS 1-00446.06,  
IEC 68-2-27 and IEC 68-2-55

### ***EMC***

Meets the following specifications:

ETSI EN 300386-2  
CENELEC EN 50082-2

### ***Safety***

Meets IEC 60950:1991 including amendments A1, A2, A3 and A4.

### ***Reliability***

The calculated Mean Time Between Failure (MTBF) as per Bell technical advisory TR-NWT-000332 for the VMapper-40 unit is:

MTBF = 224,256 Hours (25.6 Years)

## 10. ORDERING INFORMATION

This section covers the ordering information for a single 86410 VMapper-40 unit and is not intended to replace standard engineering documentation or drawings.

Please contact the Account Manager for your area regarding ordering the 86410 VMapper-40 unit.

### *Equipment and Option Code List*

Equipment	Option Code	Description
86410	-01	Provides the interface between an STM-1 Aggregate unit's TUG-3 Port and up to four Video I/O units. Used with either 86410-72 or 86410-75 paddleboard assembly.
86410	-72	Paddleboard Assembly. Provides connections for one to four Vports using standard CAT 5 (RJ45) copper cables.
86410	-75	Paddleboard Assembly. Provides connections for one to four Vports using standard CAT 5 (RJ45) copper cables. Also supports one 86413-0X Vport-F unit (installed in its J2 slot) for fibre links for Vport #1 and optionally for Vport #2.

**Table 9:** Equipment and Option Code Table

**APPENDIX A**

**LIST OF ILLUSTRATIONS**

*List of Figures*

FIGURE	DESCRIPTION	PAGE
Figure 1:	TN1Ue Video WAN .....	10
Figure 2:	Front Panel Layout .....	12
Figure 3:	VMapper-40 Unit Block Diagram .....	22
Figure 4:	Cascading VMapper-40 Units.....	24
Figure 5:	Typical Rack Layout .....	26
Figure 6:	VMapper-40 Paddleboard Assemblies .....	29
Figure 7:	VMapper-40 Unit TLCI Screen .....	39

*List of Tables*

TABLE	DESCRIPTION	PAGE
Table 1:	Video Traffic Pattern.....	11
Table 2:	Unused Bandwidth Between Nodes .....	11
Table 3:	Packet Types.....	19
Table 4:	Paddleboard Usage.....	27
Table 5:	Function Keys in TLCI Screen.....	39
Table 6:	Key Fields to Monitor.....	45
Table 7:	Troubleshooting Table.....	47
Table 8:	Dumb Terminal Commands.....	48
Table 9:	Equipment and Option Code Table .....	53

## APPENDIX B

### LIST OF ACRONYMS

- ACK Acknowledge
- A-D Analogue to Digital
- ADC Analogue-to-Digital Converter
- AIS Alarm Indication Signal
- BER Bit Error Rate
- BIP Bit Interleaved Parity
- C Container
- CENELEC Comite Européen De Normalisation Electrotechnique  
(European Committee For Electrotechnical Standardization)
- CBUS Channel Bus
- CI Craft Interface
- CPU Central Processing Unit
- DC Direct Current
- DOS Disk Operating System
- EAS Electronic Assembly Schematic
- EIA Electronic Industries Association
- EMC Electromagnetic Compliance
- EMI Electromagnetic Interference
- ESDS Electrostatic Discharge Sensitive
- ETSI European Telecommunications Standards Institute
- FPGA Field Programmable Logic Gate Array
- IEC International Electrotechnical Commission
- IEEE Institute of Electrical and Electronics Engineers
- I/O Input/Output
- LAN Local Area Network
- LED Light Emitting Diode
- LOS Loss Of Signal

## APPENDIX B

### LIST OF ACRONYMS (CONTINUED)

- MTBF Mean Time Between Failures
- NAD Node Assignment Drawing
- NMS Network Management System
- PC Personal Computer
- PLL Phase Locked Loop
- POH Path Overhead
- PSA Packet Start Address
- RAM Random Access Memory
- RCV Receive
- RFI Radio Frequency Immunity
- ROM Read-Only Memory
- SDH Synchronous Digital Hierarchy
- SONET Synchronous Optical Network
- SRAM Static Random Access Memory
- STM Synchronous Transport Module
- TLCI TN1U Local Craft Interface
- TIF TN1U Intermediate Format
- TNCI TN1U Network Craft Interface
- TPIM Technical Practice and Installation Manual
- TU Tributary Unit
- TUG Tributary Unit Group
- VCXO Voltage Controlled Crystal Oscillator
- VC Virtual Container
- VNA Video Network Address
- WAN Wide Area Network
- XMT Transmit