

TN2-86400-411PS
Issue 2
March 2002



TN1U
SDH Multiplexer

86411 VMAPPER-10 UNIT

Technical Practice
and
Installation Manual

Copyright © GE Power Management 2001

TN1U

SDH Multiplexer

Technical Practice and Installation Manual

Copyright © GE Power Management 2001, All Rights Reserved

The copyright of this document is the property of GE Power Management. This document must not be copied, reprinted or reproduced in any material form, either wholly or in part, without the written consent of GE Power Management.

GE Power Management reserves the right to make changes and modifications to any part of this document without notice.

GE Power Management is not responsible for any damages or losses incurred as a result of out-of-date or incorrect information contained in this document.

TABLE OF CONTENTS

SECTION	PAGE
1. INTRODUCTION	5
<i>Related Publication and Documentation Support</i>	<i>5</i>
<i>Handling and Packing</i>	<i>6</i>
2. UNIT OVERVIEW	7
<i>Video Transport in a TN1U Network</i>	<i>7</i>
<i>Unit Structure</i>	<i>7</i>
<i>TN1U Linear Network</i>	<i>8</i>
<i>TN1U Ring Network</i>	<i>8</i>
<i>Multiple TN1U Networks</i>	<i>9</i>
<i>TU-1 Path Test</i>	<i>9</i>
<i>Bandwidth Assignment</i>	<i>9</i>
3. FRONT PANEL FEATURES	11
<i>LED Indications</i>	<i>11</i>
<i>Push-button (ACK)</i>	<i>12</i>
<i>Craft Interface (C.I.) Jack</i>	<i>12</i>
4. UNIT DESCRIPTION	13
<i>Vport – IN Signal Path</i>	<i>14</i>
<i>Vport – OUT Signal Path</i>	<i>14</i>
<i>TIFport – IN Signal Path</i>	<i>14</i>
<i>Vport – OUT Signal Path</i>	<i>14</i>
<i>Microprocessor Operation</i>	<i>15</i>
<i>FPGA (U10) Operation</i>	<i>15</i>
<i>SRAM (U8)</i>	<i>16</i>
<i>SRAM (U9)</i>	<i>16</i>
<i>Packets</i>	<i>16</i>
<i>Input Packet Processing</i>	<i>18</i>
<i>Output Packet Processing</i>	<i>20</i>

SECTION	PAGE
5. INSTALLATION	22
<i>Preinstallation.....</i>	<i>22</i>
<i>Linear Network</i>	<i>22</i>
<i>Ring Network</i>	<i>22</i>
<i>Multiple TN1U Networks</i>	<i>23</i>
<i>Shelf Position</i>	<i>23</i>
<i>Installation</i>	<i>23</i>
<i>Paddleboard Connections</i>	<i>25</i>
<i>Paddleboard Installation.....</i>	<i>27</i>
<i>Replacing a VMapper-10 Unit in a System in Service</i>	<i>27</i>
<i>Adding VMapper-10 Unit to a System in Service.....</i>	<i>28</i>
<i>Adding VMapper-10 unit(s) on an unused TIFport.....</i>	<i>28</i>
<i>Adding VMapper-10 unit(s) on a TIFport not fully utilized</i>	<i>31</i>
6. CONFIGURATION.....	34
<i>TLCI Screen Data.....</i>	<i>34</i>
<i>Setup</i>	<i>38</i>
<i>Monitor</i>	<i>39</i>
<i>TU-11 Errors Screen.....</i>	<i>40</i>
7. MAINTENANCE and TROUBLESHOOTING	43
<i>F1 Help</i>	<i>43</i>
<i>Configuration.....</i>	<i>43</i>
<i>Key Fields to Monitor using TLCI/TNCI program.....</i>	<i>43</i>
<i>TU-Table Screen</i>	<i>44</i>
<i>TU-11 Path Testing.....</i>	<i>45</i>
<i>Troubleshooting</i>	<i>46</i>
<i>Dumb Terminal Mode.....</i>	<i>47</i>
8. UNIT PARAMETERS.....	50
<i>TIFport (Full Duplex)</i>	<i>50</i>
<i>Vport (Full Duplex)</i>	<i>50</i>
<i>Accuracy of Performance Monitors.....</i>	<i>51</i>

SECTION	PAGE
9. SPECIFICATIONS	52
<i>Physical</i>	52
<i>Electrical</i>	52
<i>Environmental</i>	52
<i>Mechanical</i>	53
<i>RFI</i>	53
<i>Reliability</i>	53
10. ORDERING INFORMATION.....	54
<i>Equipment and Option Code List</i>	54
APPENDIX A	55
<i>86411-90 Paddleboard Connections</i>	55
APPENDIX B	57
<i>List of Figures</i>	57
<i>List of Tables</i>	57
APPENDIX C	58
<i>List of Acronyms</i>	58
<i>List of Acronyms (continued)</i>	59

1. INTRODUCTION

The 86411 VMapper-10 unit is one of the family of units in GE Power Management's TN1U digital transport/access system designed specifically for the requirements of the utility (Power, Transportation, Pipelines, Oil & Gas, etc.) industry using optical fibre transmission.

This manual explains how to operate, install and maintain the 86411 VMapper-10 unit. A unit description and block diagram are included as well as detailed description of the unit's operation.

Engineering documentation includes EAS schematics for all unit circuitry.

Related Publication and Documentation Support

Additional information is provided in the TN1U Technical Overview and Reference Manual for system planning and engineering. The user may also find useful information in Technical Practice and Installation Manuals (TPIMs) for other TN1U units.

Customer inquiries for information contained in this manual should be directed to TN1U Product Line Management. GE Power Management appreciates notification of any possible errors or omissions contained herein.

Shipped with all purchased TN1U nodes is a Node Assignment Drawing (NAD) which provides necessary configuration details for the units and shelf location. Channel, TU and TIFport are some of the assignments that are shown on the NAD.

Handling and Packing

Equipment with Electrostatic Discharge Sensitive (ESDS) devices or components must be shipped in protective containers and necessary handling precautions observed otherwise all warranties, expressed or implied, will be considered null and void.

The following Electronic Industries Association (EIA) attention label appears on all GE Power Management EAS schematics and should be attached on all containers used for ESDS items to alert personnel that the contents requires special handling.

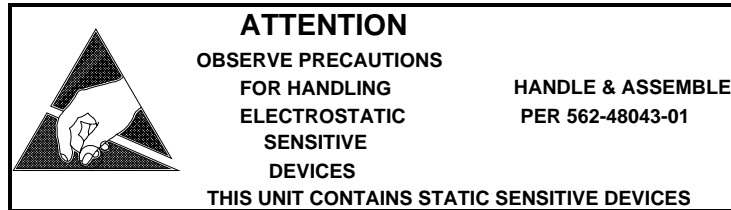

2. UNIT OVERVIEW

The 86411 VMapper-10 Unit provides the interface between Video I/O units and STM-1 Aggregate units or TUG-3 units, and is responsible for mapping the compressed video signal into the bandwidth available for transport over the TN1U network. The VMapper-10 unit is a high speed packet switching router with high speed (<1 second) automatic set-up and teardown of virtual circuit paths for maximum bandwidth utilization.

Video Transport in a TN1U Network

To transport video signals using VMapper-10 units, a WAN (wide area network) of $N \times 1.6$ Mb/s is created in a TN1U network. N refers to the number of TU-11s assigned to the video WAN and may be between 1 and 7. This TN1U network WAN is created by equipping all nodes in the system (requiring video access) with a VMapper-10 unit which connects to VMapper-10 units at the adjacent nodes using a portion (a maximum of seven TU-11s) of the inter-node SDH payload bandwidth. Note that the same set of N TU-11s is dropped to the VMapper-10 unit at every node.

The TN1U WAN comprises a linear topology with only one path between the video source and destination. This linear topology allows for bandwidth to be reused provided the total bandwidth of $N \times 1.6$ Mb/s on any link (between VMapper-10 units) is not exceeded. Note that the $N \times 1.6$ Mb/s limit is the sum of all the packet types, not just video.

The intelligent bandwidth allocation allows more bandwidth to be instantly assigned to specific video sources/cameras, allowing incident management, a higher resolution and more frames/sec for what is actually being viewed.

Unit Structure

The VMapper-10 unit occupies one shelf slot in an 86430-31 Common Equipment Shelf or 86430-02 Expansion Shelf. The VMapper-10 unit uses either two or three shelf-slot-wide paddleboard assembly (see *Paddleboard Connections* in Section 5). Any TIFport¹ may be used to add/drop VMapper-10 traffic at a TN1U node. The entire or a portion of the TIFport bandwidth (up to 7 TU-11s) is used by VMapper-10 unit.

¹ TIF is a TN1U Intermediate Format multiplex level. A TIF signal is capable of carrying a maximum of seven TU-1s (seven TU-11s or seven TU-12s, depending on its mode of operation). For more information the user is referred to the *STM-1 Aggregate Unit Technical Practice and Installation Manual* and *TN1U Technical Overview and Reference Manual*.

Each VMapper-10 unit has two TIFports and four Vports. The TIFports on the VMapper-10 unit may connect to TIFports (#1, #2, or #3) on the STM-1 Aggregate or TUG-3 units. Each Vport supports a bandwidth of up to 12.8 Mb/s and connects to a Vport on either a Video I/O unit or a VMapper unit. A video source or a monitor may be connected to a Video I/O unit.

The Vport connections may be electrical or optical. The electrical Vport connections are made on the paddleboard assembly using CAT 5 cable. The optical Vport connections are made on the Vport-F unit(s) installed adjacent to the VMapper unit on the same paddleboard.

Front panel LEDs provide indication of received TIF signal status; summary status of far-end received TU-11s, incoming signal status from Video I/O units and the unit's internal status. The unit set-up, status and port activity are reported via the TLCI and TNCI software.

TN1U Linear Network

In a linear network, at a terminal (end) node or add/drop (intermediate) node where up to four Video I/O units are to be accessed, one VMapper-10 unit and one paddleboard assembly are required. At the add/drop (intermediate) node, video traffic may be dropped from either direction. The bandwidth available between adjacent nodes is $N \times 1.6$ Mb/s ($N=1,2,\dots,7$). Bandwidth may be reused provided that the total bandwidth of $N \times 1.6$ Mb/s on any link is not exceeded.

TN1U Ring Network

In a ring network, at a node where up to four Video I/O units are to be accessed, one VMapper-10 unit and one paddleboard assembly are required. The VMapper-10 unit at one of the nodes is configured for "Ring Closer" while the VMapper-10 units at all the other nodes are configured for "Normal". This ensures video traffic in the ring is protected against path failure or fibre failure. Note that the "Ring Closer" is not passing video traffic through under normal conditions. The VMapper-10 units use the V5 byte (VC-1 POH) to determine if the ring is OK or Broken. In a ring system, under normal operating conditions, the TU-1 label '101' should be seen in V5 IN and V5 OUT for both TIFports at all VMapper-10 units in the ring. If this is not the case, a break in the ring has occurred and path protection switching is initiated. Note, if ring protection is required then the total bandwidth assigned in the ring should not exceed $N \times 1.6$ Mb/s ($N=1,2,\dots,7$).

Multiple TN1U Networks

In a TN1U system which consists of two or more TN1U networks (ring or linear) and the application is to pass video traffic between the TN1U networks, at the collocated nodes the Vports on the VMapper units are connected using a crossover cable.

TU-1 Path Test

The VMapper-10 unit continually monitors the integrity of each TU-11 path (up to 14). For path tracing, a predetermined, user selectable pattern can be inserted into all outgoing TU-11s (TIF slots) used by the VMapper-10 unit. By monitoring the incoming TU-11 content at the remote site (adjacent VMapper-10 unit in the same video network), a valid TU-11 path can be confirmed. This end-to-end TU-11 path testing is performed through the supplied TLCI software or through the TNCI. Note that a TU-11 test will kill the normal video traffic on the TU-11 path.

Bandwidth Assignment

The bandwidth assignment principles will be explained using the following network example.

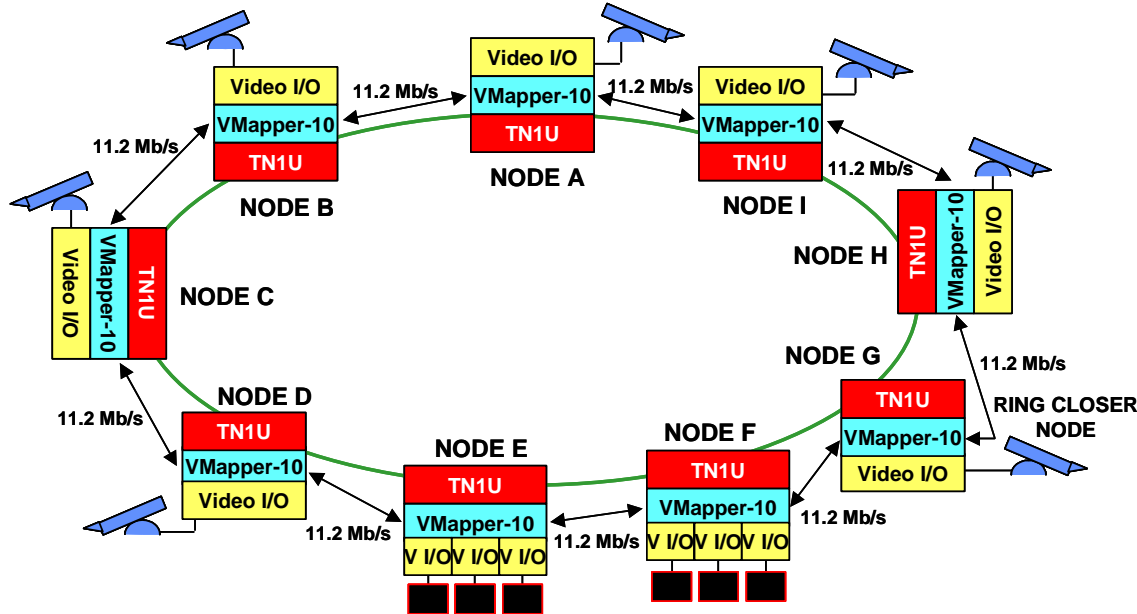

Figure 1: TN1U Video WAN

The network is a TN1U ring with Node G assigned as the "Ring Closer Node". Seven TU-1s in this ring are assigned for the video application. Note that the same set of seven TU-1s is dropped to the VMapper-10 unit at all nodes.

The video traffic pattern is as follows.

From Node	To Node	Bandwidth Assigned (Mb/s)
A	E	1.5
C	E	0.2
H	F	1.0
B	F	2.0
I	E,F	0.6

Table 1: Video Traffic Pattern

The available bandwidth between VMapper-10 units is 11.2 Mb/s (7 x 1.6 Mb/s).

Traffic between Node A and Node E

For traffic between Node A and Node E the Through nodes are B, C and D. Since the bandwidth required is 1.5 Mb/s the unused bandwidths on links A-B, B-C, C-D and D-E is 9.7 Mb/s. Note that the bandwidth on the links E-F, F-G, G-H, H-I and I-A is still 11.2 Mb/s.

Traffic between Node C and Node E

The only links affected are links C-D and D-E. Since the video traffic is 0.2 Mb/s, the unused traffic on these links is 9.5 Mb/s.

The bandwidth unused between nodes is shown below.

From Node	To Node	Band width (Mb/s)	Through Nodes	Bandwidth Unused between Nodes in Mb/s								
				A-B	B-C	C-D	D-E	E-F	F-G	G-H	H-I	I-A
				11.2	11.2	11.2	11.2	11.2	11.2	11.2	11.2	11.2
A	E	1.5	B,C,D	9.7	9.7	9.7	9.7	11.2	11.2	11.2	11.2	11.2
C	E	0.2	D	9.7	9.7	9.5	9.5	11.2	11.2	11.2	11.2	11.2
H	F	1.0	I,A,B,C,D,E	8.7	8.7	8.5	8.5	10.2	11.2	11.2	10.2	10.2
B	F	2.0	C,D,E	8.7	6.7	6.5	6.5	8.2	11.2	11.2	10.2	10.2
I	E,F	0.6	A,B,C,D	8.1	6.1	5.9	5.9	7.6	11.2	11.2	10.2	9.6

Table 2: Unused Bandwidth between Nodes

Note: If ring protection is required then the total bandwidth assigned in the ring should not exceed 11.2 Mb/s.

3. FRONT PANEL FEATURES

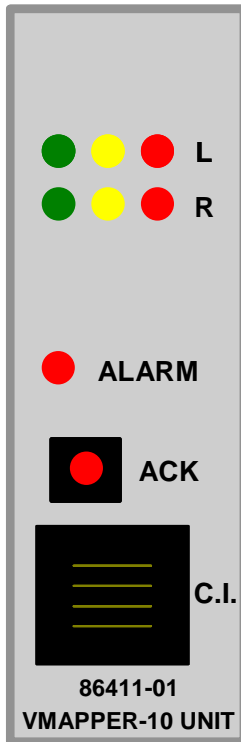

Figure 2: Front Panel Layout

LED Indications

TIFport Green (L&R)

A steady green LED indicates that the port is configured as "assigned" and the received TIF signal is OK.

TIFport Yellow (L&R)

A steady yellow LED ON indicates that the far-end VMapper-10 unit is not receiving a good TIF signal, i.e. at least one of the far-end received TU-11s has an abnormal condition. This is "VC-1 Path Yellow".

Flashing yellow and red LEDs indicate a loss of clock from the TIFport on the STM-1 Aggregate unit or TUG-3 unit.

TIFport Red (L&R)

A steady red LED indicates that the TIF signal to the VMapper-10 unit is not valid (Path AIS or High BER on any of the TU-11s assigned to the TIFport) or the unit is not connected to a VMapper-10 unit at the far end. The Green and Yellow LEDs are usually extinguished when the Red LED is steady on.

ALARM (Red)

A steady red ALARM LED indicates one of the following:

- Paddleboard is missing
- VCXO voltage is out of range
- Unit temperature is high (>93°C)
- FPGA (Xilinx) did not boot
- Alarm on an assigned Vport (LOS or high BER).

A flashing red ALARM LED is seen when all the above (steady red ALARM LED) conditions are OK and one of the following conditions exists:

- Unit is receiving duplicate "Hello" packets i.e. more than one (of the six ports) are receiving "Hello" packets with the same VNA# address
- Alert on Video I/O unit (e.g. Video LOS)
- Alarm on Video I/O unit (e.g. VCXO control voltage out of range)

Push-button (ACK)

The first use of the push-button is a LED and microprocessor test. If the VMapper-10 unit is operating normally, holding the front panel pushbutton down causes all the LEDs to light. The main use for this test is to determine that the front panel LEDs are functional and that the microprocessor firmware code is running normally (microprocessor is not locked up).

Note: *The microprocessor test does not cause any disruption in traffic.*

The second use of the push-button is to put the unit into a "sleep state". This state is enabled when the VMapper-10 unit is inserted in the shelf with the ACK button pressed. In this condition, the micro ignores all settings on the unit until the TLCI software is run. On establishing the TLCI connection with the unit, the TLCI will automatically clear the TIFport slot settings at which point the user can configure the unit to the desired settings. If the unit is inserted with the ACK button pressed and then removed (without establishing TLCI connection to the unit) and inserted normally, all previous settings will remain.

Craft Interface (C.I.) Jack

The Craft Interface allows a user to connect a PC computer serial (COM) port to the unit. The CI is an RJ-11 connector, which transmits and receives a 9600 b/s RS-232 signal. The supplied DOS-based TLCI (TN1U Local Craft Interface) software allows the user to configure the unit and monitor its status through the CI port.

4. UNIT DESCRIPTION

The 86411-01 VMapper-10 unit provides the interface between a TIFport (#1, #2 or #3) of an STM-1 Aggregate unit or TUG-3 unit and up to four Vports (four Video I/O units). It uses N TU-1s (N=1,2,...,7) of the STM-1 signal.

The unit occupies one shelf slot in a TN1U equipment shelf.

The unit has the 087-86411-01 main assembly board which houses the microprocessor (U4), the Field Programmable Logic Gate Array (U10), SRAM (U8), SRAM (U9), VCXO (U11 and U13), DC/DC Converter (U1).

The unit performs the following functions:

- Interfacing to the two TIFport signals;
- Interfacing to the four Vport signals;
- Buffering the incoming packets from all the six ports of the unit;
- Routing the incoming packets to the correct destination ports;
- Automatic set-up and teardown of packet routing switches;
- Storage of the VNA# table plus the "to-do" lists for each of 6 output ports and micro;
- Monitoring of the temperature sensor;
- Control of the front panel LEDs and monitoring of the ACK push-button;
- Reporting the unit status and responding to configuration requests from the Craft Interface or NMS;
- Providing visibility of Video I/O unit alarms.

The Vport connections may be electrical or optical. The electrical Vport connections are made on the 86411-9X paddleboard assembly using CAT 5 cable. The optical Vport connections are made on the Vport-F unit(s) installed adjacent to the VMapper unit on the same paddleboard.

A simplified Functional Block Diagram of the unit is included at the end of this section and can be used for reference to follow the signal paths; however, the user should refer to schematics EAS-86411-01 for complete circuit details.

The description of the signal paths is with reference to one of the four Vports, namely Vport #1. Also, the description refers to an electrical Vport connection.

Vport – IN Signal Path

The Vport DATA IN signal is received on the paddleboard's RJ45 connector and passed through the coupling transformer (T2) and backplane connector J1(C15) to the main assembly board 087-86411-01. The incoming data is monitored for Code Violations (BER) and Low Level. The incoming data must be synchronous. The Vport signal format comprises a framing pattern, followed by eight 25-byte packets, ending with a check bit for error monitoring, per 125 μ s frame.

Vport – OUT Signal Path

The packets from U10 are fed to the paddleboard assembly via backplane connector J1(B15) where they are passed through the coupling transformer (T2) and outputted on the RJ45 connector as DATA OUT.

TIFport – IN Signal Path

The signal is received on the TIFport and through the balun transformers sent to the FPGA (U10). U10 selects N (N=1,2,...,7) TU-11s from the TIFport signal and terminates their POH.

The VC-1 Path Label bits in the V5 byte are used to determine the ring's health. The "Ring Closer" unit normally generates VC-1 Path Label '101'. All "Normal" units receiving healthy TU-1 signals pass these bits through. A "Normal" unit receiving an abnormal TU-1 signal generates TU-1 path label '111'. The Ring Closer unit can thus detect any ring break by checking if the received TU-1-path label bits are not '101', in which case the unit enables its right port (which is normally disabled). If the "Ring Closer" is receiving AIS on its left TIFport, it changes the label bits out of its right TIFport to '111', and vice versa.

Vport – OUT Signal Path

The signal is outputted through the balun transformers to the TIFport connector on the paddleboard. The TIFport connection comprises SYNC, CLOCK, XMT and RCV balanced pairs. The pairs are balanced for EMI and RFI immunity.

Microprocessor Operation

U4, the HC16 microprocessor, is the CPU for the VMapper-10 unit. For memory the micro uses the 128 kbytes static RAM (U6), the 256 kbytes Flash EEROM (U7). The CPU provides the following:

- Communication with the user through the Craft Interface port;
- Control of all front-panel LEDs and monitoring of the ACK push-button switch;
- Monitoring of the unit temperature sensor LM34 (U5) and reporting local unit temperature;
- Configuration of the FPGA U10;
- Monitoring data from the FPGA;
- Communication of the unit status and alarm information to the STM-1 Aggregate or TUG-3 unit for the Network Management System (TNCl);
- Processing the configuration requests from TLCl and TNCl.

The 32.768 kHz crystal Y1 forms an oscillator with the micro, which multiplies it for an internal 16.78 MHz CPU clock.

FPGA (U10) Operation

The VMapper-10 unit uses a Xilinx Field Programmable Gate Array (FPGA) U10 to:

- Sample and drive the TIFport interface and Vports;
- Facilitate the NMS communications;
- Implement a Phase Locked Loop circuit in conjunction with an external Voltage-Controlled Crystal Oscillator (U13) and multiplier (U11) to synchronize the on-board 16.2 MHz clock (provided by VCXO U13) to the TIFport clock
- Use 64.8 MHz clock to over-sample the 16.2 MHz input Vports and recover incoming data;
- Perform packet processing functions.

U10 also terminates the NMS information and passes the incoming packets.

SRAM (U8)

The VMapper-10 unit uses a 128k x 8 high speed SRAM U8 to:

- Buffer incoming packets from all six ports of the unit

SRAM (U9)

The VMapper-10 unit uses a 64k x 16 high speed SRAM U9 for

- The 8192-entry VNA# table, seven 4096-entry "to-do" lists for each of the six output ports, plus a "to-do" list for the unit's micro.

Packets

All data on the Video WAN is encoded in 25-byte packets. The first three bits of the packet's first byte identify the type of packet while the remaining five bits of the first packet and the eight bits of the second byte are used to form the 13-bit Packet Header Address (PHA). Thus there are total of 8192 addresses available. The highest 511 addresses (m1 to m511) are assigned to VMapper units, 6143 addresses (1 to 6143) are assigned to Video I/O units, and the ones in the middle are either unused or used for different packet routing options (see Video I/O Unit TPIM for more information).

There are six different types of packets and their functions are listed below.

Packet Type	Header Bytes	Description	Function
Link	011+ VNA#	Regularly broadcast by each unit, and are not passed on.	Helps each unit to learn the VNA# of its neighbours (unless the unit is to right of a Ring Closer unit) and identifying any dead links.
Hello	001 + VNA#	Regularly broadcast by each unit, and passed through every other unit, to reach all other units in the network.	Each unit keeps a table so that it knows the entry port of each VNA#.

Wanted	010 + VNA#	<p>Broadcast by each unit wanting to receive video from another unit</p> <ul style="list-style-type: none"> - Each VMapper-10 unit receiving a WANTED packet looks at its table to see if it has an entry for the VNA#; if so, it passes the packet to the recorded port (producing the VNA# "Hellos"). - The unit routing this packet puts an entry in the table to flag the port producing the packet. If more than one monitor wants the same source, there will be more than one flagged port in the table for that particular VNA#. - Remove the flags if the "WANTED" packets cease. - The third byte in the "WANTED" packet indicates the spare capacity of the path by having each VMapper-10 unit compare the byte with its port's idle rate. 	<p>"WANTED" packets find their way to the other unit.</p> <ul style="list-style-type: none"> - quick teardown of obsolete paths to maintain the full bandwidth for the active paths. - allows the source unit to know whether it can accommodate a request for more bandwidth.
Payload	10X + VNA#	<p>Broadcast by each Video I/O unit transmitting data.</p> <ul style="list-style-type: none"> - Each VMapper-10 unit receiving a "Payload" packet looks at its table to 	<p>Payload packets find their way directly to (all) the destination(s).</p>

		see if it has any flagged ports for the VNA#; if so, it passes the packet to the recorded port(s) producing the VNA# "WANTED".	
Message	110 + VNA#	Used for messages exchanged between the units' microprocessors. Also, all data-port and Contact I/O data is transported in "Message" packets (see Video I/O Unit TPIM for more information). Each VMapper-10 unit receiving a "Message" packet looks at its table to see if it has an entry for the VNA#; if so, it passes the packet to the recorded port (producing the VNA# "Hellos").	Message packets find their way directly to the other unit.
Idle	000+13 zeros	Each VMapper-10 and Video I/O unit transmits "idle" packets as required.	To maintain continuous packets on all ports.

Table 3: Packet Types

Input Packet Processing

As each packet is written to its buffer area (the Packet Start Address – PSA is noted), the packet's 3-bit header is used to control which of the actions to invoke.

001 "HELLO" PACKETS

The packet's VNA# is used as an index to the unit's VNA table. For each VNA, the table has four fields. They are:

- A 1-bit HFLAG - set by each incoming "HELLO" packet;
- A 3-bit HPORT field – to encode the source port for "HELLO" packets;
- A 6-bit WPORT field – 1 bit for each of the unit's ports;
- A 6-bit WFLAG field – 1 bit for each of the unit's ports.

Each Video I/O unit or VMapper-10 unit outputs a "HELLO" packet at least once per minute (<once per second for normal video). The HFLAG is set by each incoming "HELLO" packet. A polling routine checks and clears the HFLAG bit for each VNA# once per minute; if the routine finds an entry with the bit already cleared, it deletes the remaining fields. This ensures that the VNA table is kept reasonably current.

The HPORT field is updated with the port originating the "HELLO" packets. If this changes and it happens repetitively, this VNA# is not unique in the Video Network System and the "Duplicate-Hello" alert is activated.

For each of the 6 ports, if both the WPORT and WFLAG fields are set, the WFLAG field's bit is cleared (this starts the "teardown" of an obsolete path to a monitor). If the WPORT field is set and the WFLAG field bit is already cleared, then the WPORT field bit is cleared (this completes the "teardown" of an obsolete path).

The packet's PSA is placed on the "to-do" list of either 5 or 6 of the unit's 6 output ports (hairpinning is suppressed on the TIFports, and on any Vports connected to VMapper-10 units).

010 "WANTED" PACKETS

The packet's VNA# is used as an index to the unit's VNA table.

The corresponding WPORT and WFLAG fields' bits for the packet source port are set.

The packet's PSA is placed on the "to-do" list for the port whose bit is set in the HPORT field.

10x "PAYLOAD" PACKETS

The packet's VNA# is used as an index to the unit's VNA table.

The packet's PSA is placed on the "to-do" list for the ports whose bits are set in the WPORT field.

110 "MESSAGE" PACKETS

The packet's VNA# is used as an index to the unit's VNA table.

If the VNA# matches that of the unit, the packet's PSA is placed on the "to-do" list for the micro; otherwise it is put on the "to-do" list for the HPORT field port.

011 "LINK" PACKETS

The packet's PSA is placed on the "to-do" list of the unit's micro.

000 "IDLE" PACKETS

No action is taken. (These incoming packets go nowhere).

Output Packet Processing

For each of the 6 output ports, when a new packet is required, the oldest waiting entry on its "to-do" list is used.

If the "to-do" list is empty, an idle packet is sent.

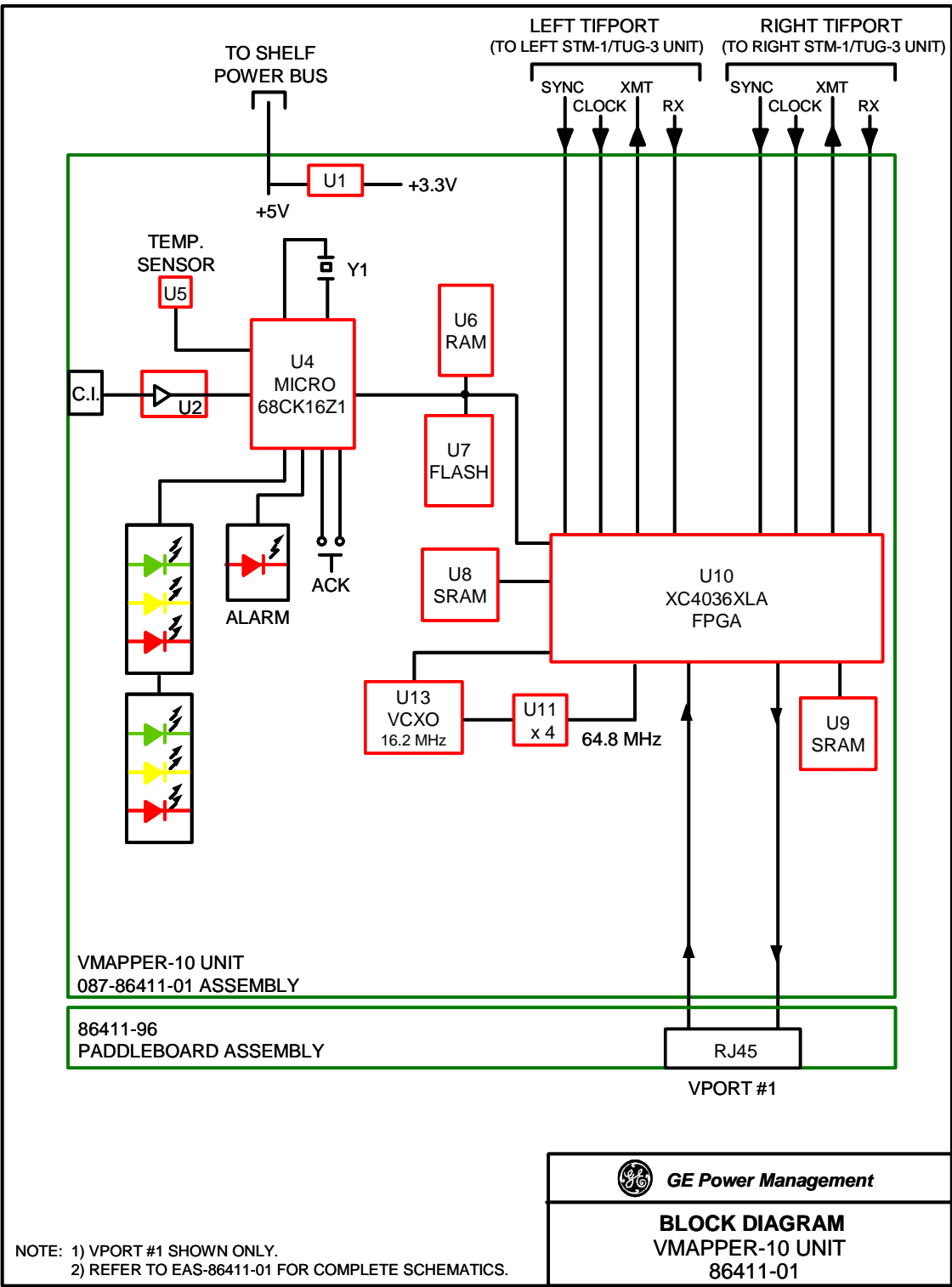

Figure 3: VMapper-10 Unit Functional Block Diagram

5. INSTALLATION

The following section provides information for installing an 86411 VMapper-10 unit. The unit is shipped from the factory configured as per the Node Assignment Drawing for the purchased system. All spare units or loose units are shipped with factory default settings in memory.

CAUTION

The VMapper-10 unit has ESDS components and therefore standard static protection precautions should be observed when handling, packing or shipping the unit.

Preinstallation

Visually check the unit for damage. Ensure that screws are firmly tightened and in place. Keep the shipping containers and packing materials for future use. If a unit is damaged, file a claim with the shipping agent or local GE Power Management representative.

Linear Network

At a node in a linear network, one VMapper-10 unit and one paddleboard assembly are required. At the terminal node, the left TIFport on the VMapper-10 unit is connected to a TIFport on the STM-1 Aggregate (or TUG-3) unit. At the add/drop node the left and right TIFports on the VMapper-10 unit are connected to the TIFports (#1, #2 or #3) on the left and right STM-1 Aggregate/TUG-3 units respectively.

Ring Network

At a ring node, one VMapper-10 unit and one paddleboard assembly are required. The left and right TIFports on the VMapper-10 unit are connected to the TIFports (#1, #2 or #3) on the left and right STM-1 Aggregate (or TUG-3) units respectively. One of the VMapper-10 units is configured for "Ring Closer" while all other VMapper-10 units are configured as "Normal".

Multiple TN1U Networks

In a TN1U system which consists of two or more TN1U networks (ring or linear) and video traffic is to be passed between the TN1U networks, at the collocated nodes the appropriate Vports on the VMapper units are connected using a crossover cable. This creates a "Vport-tie connection".

Note: *It is important, when extending the Video WAN through Multiple TN1U networks, to ensure there is only one video path between any two VMapper units in the system.*

Shelf Position

The 86411-01 VMapper-10 unit can be installed in slots 2 to 10 of an 86430-31 Common Equipment Shelf and slots 2 to 14 of an 86430-02 Expansion Shelf. It must be aligned with the J1 slot of an 86411-9X paddleboard (Figure 5) which may be installed in slots 2 to 11 of the Common Equipment Shelf backplane.

If one or more optical Vports are required, a maximum of two 86413-0X Vport-F units may be installed immediately to the right of the VMapper units on the same paddleboard (see Figure 5). The paddleboard slots not equipped with Vport-F units are equipped with blank units.

Figure 4 shows a typical rack layout for a ring-configured system as it appears on a NAD.

Installation

Before installing the VMapper-10 unit in the shelf, verify that 087-86430-90 CBUS jumper (used to extend the CBUS on the Shelf back plane) is not installed underneath nor on either side of the VMapper-10 unit paddleboard.

The VMapper-10 unit can be inserted and removed from the shelf with shelf power applied; however, certain precautions should be taken before inserting or removing the unit from a system in service. Refer to the Sections *Replacing a VMapper-10 Unit in a System in Service* and *Adding VMapper-10 Unit to a System in Service* before taking any action.

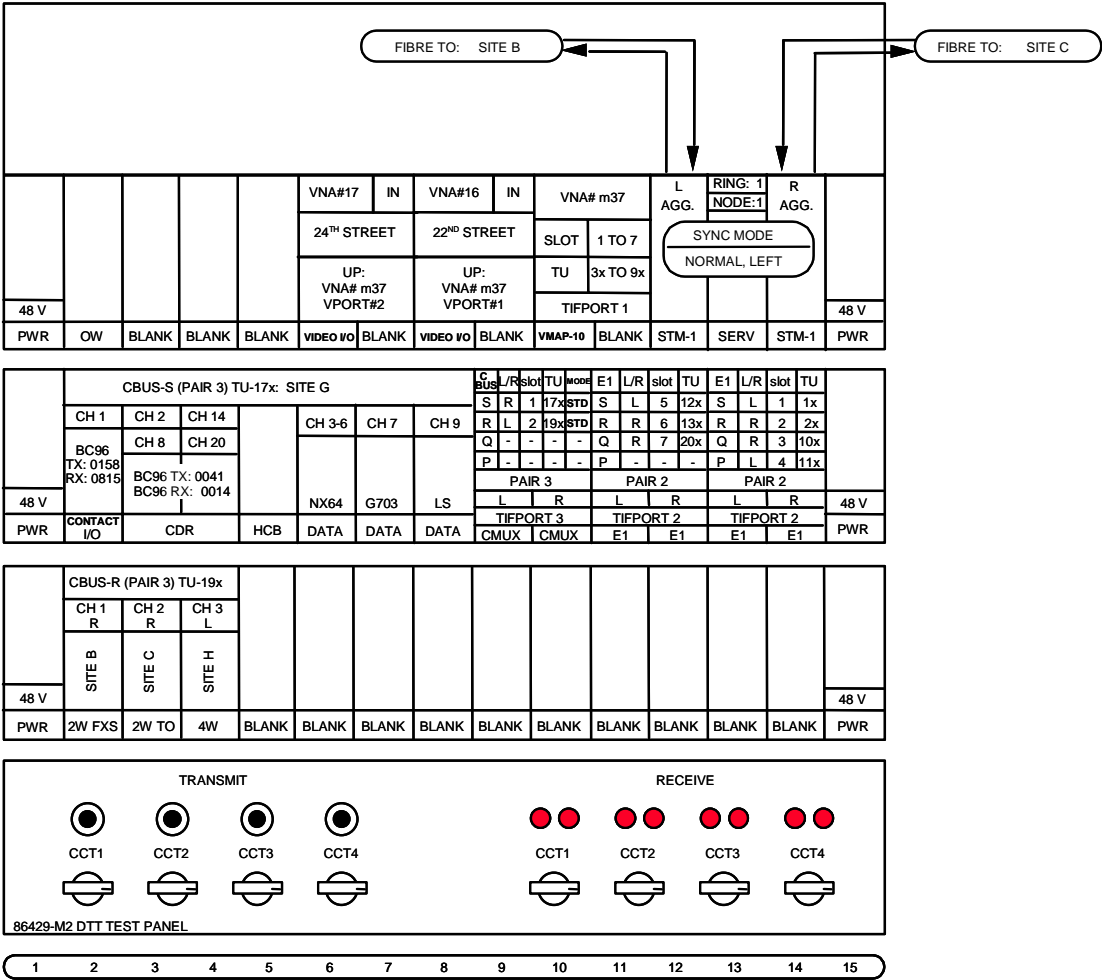

Figure 4: Typical Rack Layout

Paddleboard Connections

Each VMapper-10 unit requires one 86411-9X Paddleboard. The Paddleboard provides Vport connections to the unit.

There are two types of paddleboards offered with a VMapper-10 unit: a two-shelf-slot-wide 86411-96 paddleboard (Figure 5a) and a three-shelf-slot-wide 86411-97 paddleboard (Figure 5b). Which of the two paddleboards is used depends on the number of optical Vports needed. Electrical Vport connections are made on the paddleboard's RJ-45 connectors while the optical Vport connections are provided by Vport-F unit(s)² installed on the same paddleboard with the VMapper-10 unit. For information on which of the two paddleboards may be used for a particular application, refer to the table below.

Number of optical Vports required	Paddleboard	Unit installed in the paddleboard's slot J2	Unit installed in the paddleboard's slot J3
NONE	86411-96 ¹⁾	None	N/A
ONE (Vport #1)	86411-96 ¹⁾	86413-01 or 86413-02 ²⁾ with Jumper J2 set for Disabled	N/A
TWO (Vports #1, 2)	86411-96 ¹⁾	86413-02 with Jumper J2 set for Enabled	N/A
THREE (Vports #1, 2, 3)	86411-97	86413-02 with Jumper J2 set for Enabled	86413-01 or 86413-02 ³⁾ with Jumper J2 set for Disabled
FOUR (Vports #1, 2, 3, 4)	86411-97	86413-02 with Jumper J2 set for Enabled	86413-02 with Jumper J2 set for Enabled

¹⁾ 86411-97 paddleboard may be used instead (with its J3 slot unused). This may be a preferable solution if Vport #3 and/or Vport #4 are expected to be converted to optical ones in the future.

²⁾ May be a preferred solution if Vport #2 is expected to be converted to an optical one in the future.

³⁾ May be a preferred solution if Vport #4 is expected to be converted to an optical one in the future.

Table 4: Paddleboard Usage

² For more information on 86413-0X Vport-F unit refer to the Vport-F unit TPIM.

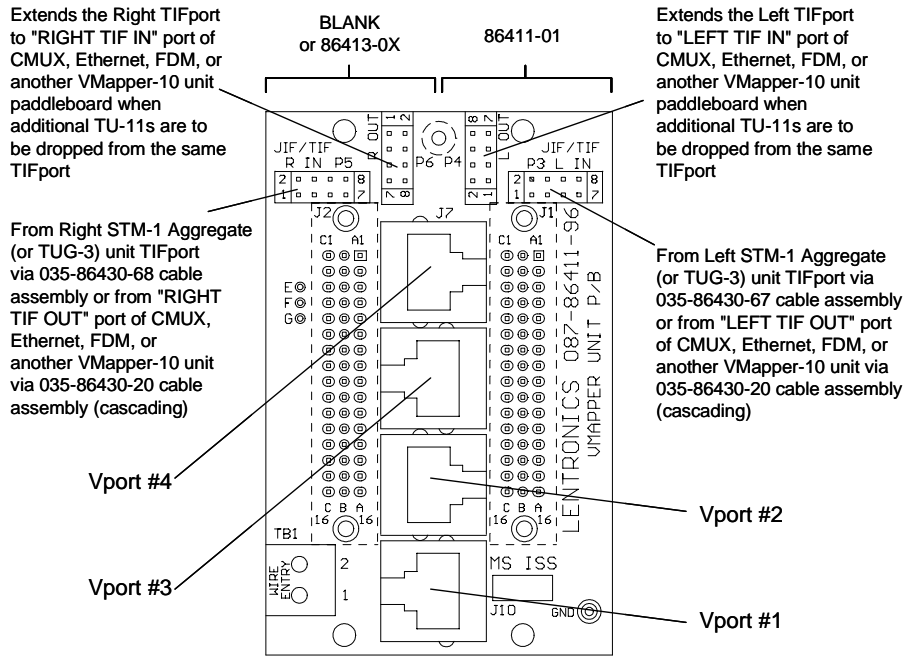

WARNING

For correct operation, the CBUS Jumper 087-86430-90 must not be installed underneath nor on either side of the VMapper-10 unit paddleboard.

When connecting a VMapper-10 unit to a Video I/O unit electrically, a Vport on the VMapper-10 unit is connected to a Vport on the Video I/O unit using a straight-through CAT 5 cable. For this purpose, cables 135-86411-01 (30 cm), 135-86411-02 (60 cm), 135-86411-03 (90 cm), 135-86411-04 (1.2 m) or 135-86411-05 (1.5 m) are used. The cable selection depends on the distance between the VMapper-10 unit and respective Video I/O unit.

To connect the Vports on two VMapper units (Vport-tie connection), a Vport on one VMapper unit is connected to a Vport on the other VMapper unit using a crossover CAT 5 cable. For this purpose, cables 135-86411-06 (1 m), 135-86411-07 (3 m), or 135-86411-08 (6 m) are used. The cable selection depends on the distance between the two VMapper units.

Paddleboard Installation

1. Place the Paddleboard onto the designated slot position ensuring that the rear connectors are fully mated. Ensure correct orientation of the Paddleboard prior to insertion.
2. Secure the Paddleboard in position using fixing screws provided.
3. Remove the plastic cover from the TIFports and connect the TIFport cables as per NAD.
4. Install the plastic cover back onto the paddleboard.

Replacing a VMapper-10 Unit in a System in Service

Removing a VMapper-10 Unit

1. Use the TLCI program to display the unit configuration. Write down the settings in all configurable fields so that the replacement unit can later be configured the same.
2. Use the red tab on the face plate of the unit to ease the unit from the TN1U shelf.

Inserting a Replacement VMapper-10 Unit

WARNING

Inserting the VMapper-10 unit into a working position without ACK button pressed may cause traffic disruption in an in-service system!

WARNING

Do not use the red tab to force the unit into the shelf as this could result in damage to the red tab.

1. With the ACK button pressed, gently insert the VMapper-10 unit into the shelf by pressing the front panel. (Ensure the red tab is not preventing the unit from insertion.) When inserted with the ACK button pressed, the VMapper-10 unit is in the "Sleep State" with the interrupts enabled; any earlier programming on this VMapper-10 unit is disabled at this point. (Note, the unit need not be inserted with ACK button pressed if the user is sure that the unit is programmed correctly, i.e. same as the previously removed unit.)
2. Use the TLCI program to program the unit parameters in the same way as they were programmed on the replaced unit. Do not program the slot assignment fields until you have properly programmed all other unit parameters.

Adding VMapper-10 Unit to a System in Service

Adding VMapper-10 unit(s) on an unused TIFport

In the example in Figure 6, TU-1#15,16,17,18,19,20,21 are to be dropped on TIFport #2 on both left and right STM-1 Aggregate units and are terminated on a VMapper-10 unit. (Alternatively, if applicable, the shelf could be equipped with TUG-3 units, and the following procedure would also apply.)

1. Run TLCI and plug into the STM-1 Aggregate unit (or TUG-3 unit, if applicable).
2. Locate an unused TIFport and program it for TU-11 mode of operation.
3. Assign TU-1s to slots on the selected TIFport in ascending order (TU-1#15 to slot 1, TU-1#16 to slot 2, etc.) Refer to the TPIMs for STM-1 Aggregate and TUG-3 units for more information on their configuration.
4. Repeat steps 1 to 3 for the companion STM-1 Aggregate (or TUG-3) unit (applicable at ring nodes and add/drop nodes in linear networks).

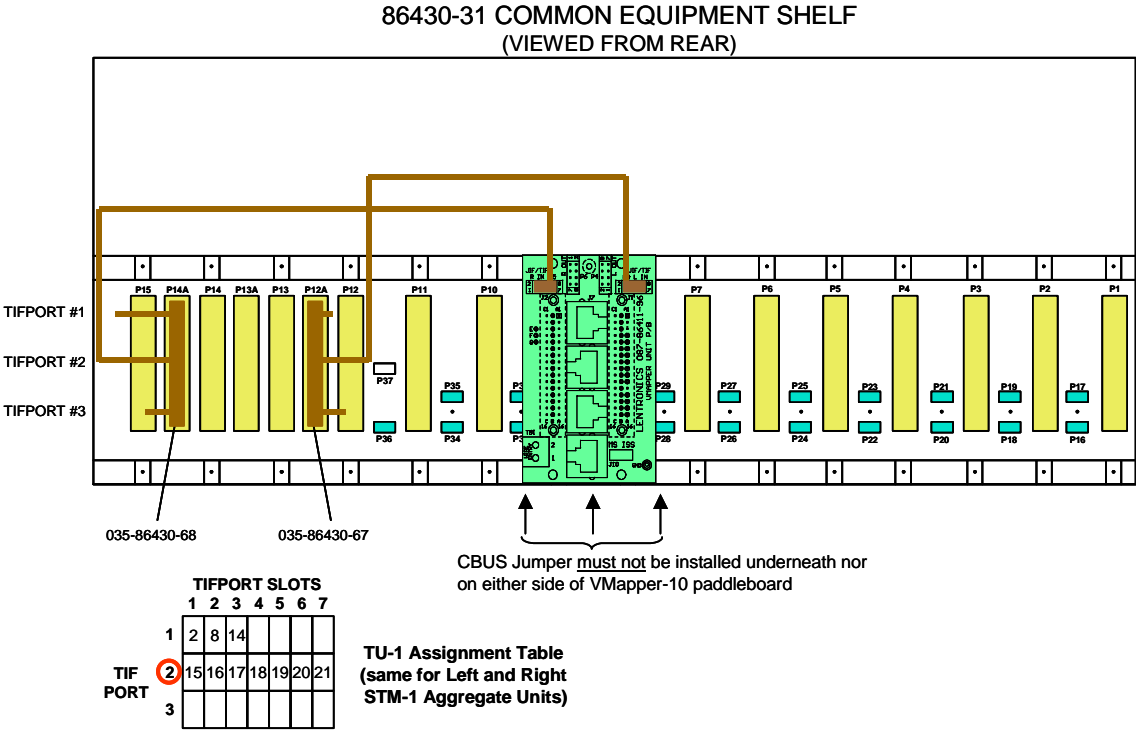

Figure 6: Example of TU-1s dropped on an unused TIFport (ring application)

5. Install the VMapper-10 unit paddleboard on the shelf backplane (refer to *Shelf Position and Paddleboard Installation*). Ensure that the CBUS Jumper (087-86430-90) is not installed in the backplane underneath nor on either side of the paddleboard.
6. Establish TIFport cable connections from the left and right STM-1 unit's TIFport to the Left IN and Right IN 8-pin headers (P3 and P5) of the VMapper-10 unit Paddleboard respectively (see Figure 6). (For more information on the shelf connectors and cabling refer to the *TN1U Equipment Shelf TPIM and CA86450 Cable Assembly* drawing).

Note: At a terminal (end) node in a linear network, only the unit's left TIFport (Left IN header) is connected to the STM-1 Aggregate unit.

WARNING

Do not use the red tab to force the unit into the shelf as this could result in damage to the red tab.

7. Gently insert the VMapper-10 unit into the shelf by pressing the front panel. (Ensure the red tab is not preventing the unit from insertion.)
8. Run TLCl and plug into the VMapper-10 unit. Program the used TIFports to "Assigned". Note, both left and right TIFports are assigned, except at a terminal node where only the left TIFport is assigned.
9. For each assigned TIFport, program the VMapper-10 unit for proper slot assignments. Go to the "F8" TU-1 Errors TLCl screen to verify that the correct TU numbers are displayed for the assigned slots.
10. Refer to the Node Assignment Drawing and configure the unit for:
 - Unique VNA#. The number must be in the range 1-511.
 - Type "Normal" or "Ring Closer". Note, only one VMapper-10 unit in a ring should be configured as "Ring Closer".
 - Sync Normal
11. If any Vport-F units are to be installed with the VMapper unit, do the following:
 - Ensure that the shelf slot where the Vport unit is to be inserted has been properly selected and the proper paddleboard is installed on the backplane (see Table 4 and Figure 5).
 - (For 86413-02 unit only) Set Jumper 2 for the unit's desired mode of operation (see Table 2 in Vport-F unit TPIM).
 - Insert the Vport-F unit into the shelf and establish fibre connections on the top of the unit.
12. Assign the used Vports.

After power-up, expect to see only green LEDs ON; if not, see the Troubleshooting section.

After two minutes (or longer):

1. Check that the "number of alive" Video I/O and VMapper units correspond to the number of units installed.
2. Check that the reported VNA# agree with those assigned.

Note: After major system changes/reconfigurations (or whenever necessary), use both TLCl software and dumb terminal commands Z1, Z7A and Z7B at each and every VMapper unit in the system to confirm that the system is functioning according to the network designer's intention (for more information on dumb terminal commands refer to Section 7).

Adding VMapper-10 unit(s) on a TIFport not fully utilized

The VMapper-10 unit could be installed on the same TIFport that is used by a CMUX or Ethernet unit (provided that not all 7 slots are used on the TIFport). The cascaded units are installed in adjacent shelf slot positions. Cable assembly 035-86430-20 is used to interconnect the cascaded units (Figure 7).

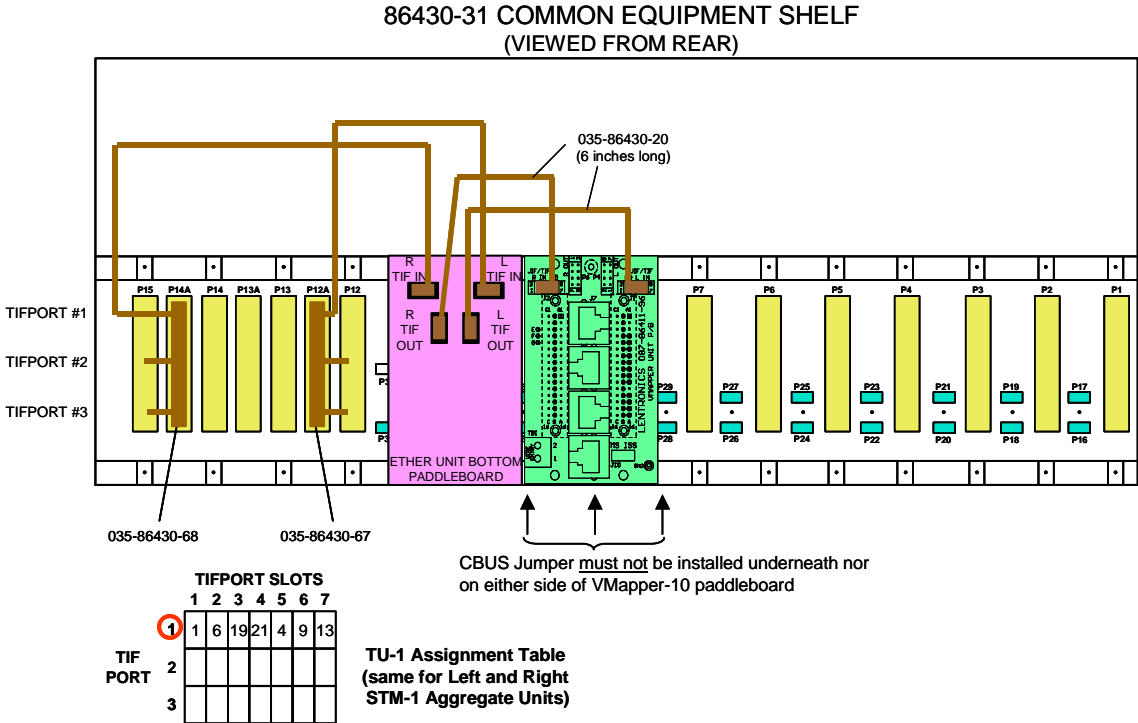

Figure 7: Example of TU-1s dropped on a TIFport not fully utilized (ring application)

In the above example TU-1#1,6,19,21 are already being dropped on the TIFport#1 and terminated on a pair of Ethernet units. TU-1 #4,9,13 are dropped on the same TIFport and terminated on a VMapper-10 unit. (Alternatively, if applicable, the shelf could be equipped with TUG-3 units, and the following procedure would also apply.)

1. Run TLCI and plug into the STM-1 Aggregate unit (or TUG-3 unit, if applicable).
2. Program the STM-1 Aggregate unit to drop the TU-1s selected for video usage on unused TIFport slots in ascending order (TU-1#4 to slot 5, TU-1#9 to slot 6, TU-1#13 to slot 7). Refer to the TPIMs for STM-1 Aggregate and TUG-3 units for more information on their configuration.

3. Repeat steps 1 and 2 for the other STM-1 Aggregate (or TUG-3) unit (applicable at ring nodes and add/drop nodes in linear networks).
4. Install the VMapper-10 unit paddleboard in the shelf slots adjacent to the paddleboard of the (pair of) cascaded unit(s) (see Figure 7; refer to *Shelf Position and Paddleboard Installation*). Ensure that the CBUS Jumper (087-86430-90) is not installed in the backplane underneath nor on either side of the paddleboard.
5. Establish TIFport cables from the Left and Right STM-1 units' TIFport #1 to the Left IN and Right IN 8-pin headers (P3 and P5) respectively, of the VMapper-10 unit Paddleboard (see Figure 7). (For more information on the shelf connectors and cabling refer to the *TN1U Equipment Shelf TPIM and CA86450 Cable Assembly* drawing).

Note: At a terminal (end) node in a linear network, only the unit's left TIFport (P3) is connected to the STM-1 Aggregate unit.

WARNING

Inserting the VMapper-10 unit into a working position without ACK button pressed may cause disruption of the existing traffic!

WARNING

Do not use the red tab to force the unit into the shelf as this could result in damage to the red tab.

6. Insert VMapper-10 unit into the shelf by pressing the front panel. (Ensure the red tab is not preventing the unit from insertion.) Note, if the unit is being added to a system already in service, insert it with ACK button pressed. (When inserted with ACK button pressed, the VMapper-10 unit is in the "sleep state"; any earlier programming on this VMapper-10 unit is disabled at this point).
7. Run TLCI and plug into the VMapper-10 unit. Refer to the Node Assignment Drawing and configure the unit for:
 - Unique VNA#. The number must be in the range 1-511.
 - Type: "Normal" or "Ring Closer". Note, only one VMapper-10 unit in a ring should be configured as "Ring Closer".
 - Sync: Normal
8. If any Vport-F units are to be installed with the VMapper unit, do the following:

- Ensure that the shelf slot where the Vport unit is to be inserted has been properly selected and the proper paddleboard is installed on the backplane (see Table 4 and Figure 5).
 - (For 86413-02 unit only) Set Jumper 2 for the unit's desired mode of operation (see Table 2 in Vport-F unit TPIM).
 - Insert the Vport-F unit into the shelf and establish fibre connections on the top of the unit.
9. Program the used TIFports to "Assigned". Note, both left and right TIFports are assigned, except at a terminal node where only the left TIFport is assigned.
10. For each assigned TIFport, program the VMapper-10 unit for proper slot assignments. Go to the "F8" TU-1 Errors TLCl screen to verify that the correct TU numbers are displayed for the assigned slots.
11. Expect to see only green LED(s) ON. If not, see the Troubleshooting section.

After two minutes (or longer):

- Check that the reported number of "alive" Video I/O and VMapper units corresponds to the actual number of these units in the Video WAN.
- Check that the reported VNA numbers on all assigned ports are as expected.

Note: *After major system changes/reconfigurations (or whenever necessary), use both TLCl software and dumb terminal commands Z1, Z7A and Z7B at each and every VMapper unit in the system to confirm that the system is functioning according to the network designer's intention (for more information on dumb terminal commands refer to Section 7).*

6. CONFIGURATION

To configure the 86411-01 VMapper-10 unit, connect a PC running the supplied TN1U Local Craft Interface (TLCI) software to the CI jack on the front of the unit. An 84910-05 RJ-11 cable and an 84910-06 (9-pin adapter) or 84910-07 (25-pin adapter) or equivalent are required.

The software displays programmable fields, information about the unit and the unit status. The unit will be shipped with the programmable fields set as per the Node Assignment Drawing (NAD) for the purchased system.

The VMapper-10 unit does not have any hardware adjustable options. All configurations are performed through the supplied TLCI software.

TLCI SCREEN INFORMATION

The user should refer to Figure 8 (VMapper-10 unit TLCI Screen). An explanation of each field and their function follows.

TLCI Screen Data

PORT (Not Adjustable)

The VMapper-10 unit has six available ports for connection. The TIFports on the paddleboard connect to the corresponding TIFports on the STM-1 Aggregate (or TUG-3) units. Each of the four Vports on the paddleboard assembly may connect to the Vport on a Video I/O unit or the Vport on a VMapper unit.

VNA (Not Adjustable)

Each VMapper unit and Video I/O unit has its own unique Video Network Address (VNA). This field displays the VNA number of the unit connected to this port. A VNA address for a VMapper unit is in the range 1 – 511 and is always displayed with the letter "m" preceding the number. A VNA address for a Video I/O unit is in the range 1 – 6143.

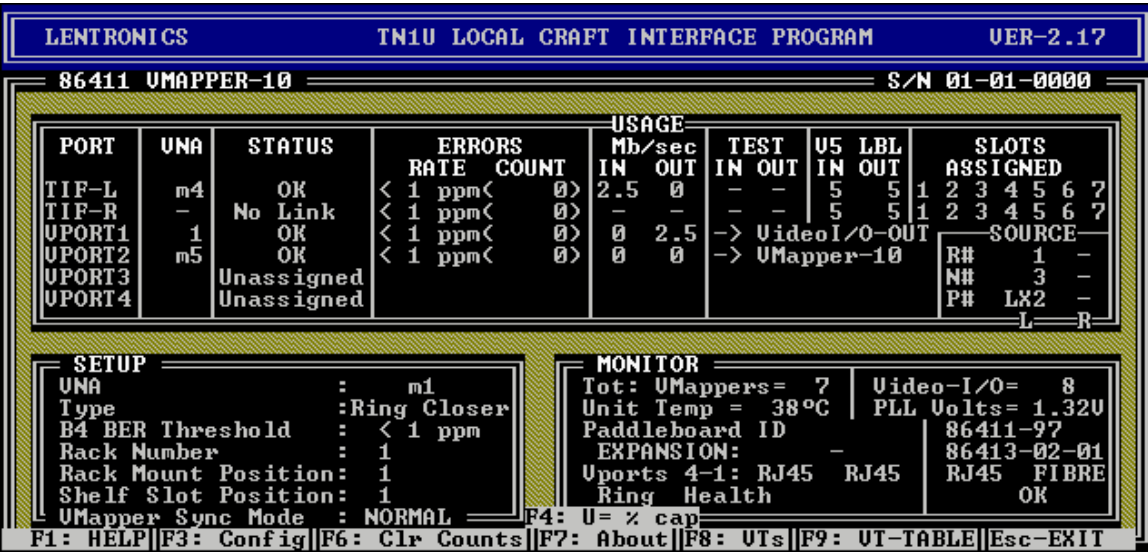

Figure 8: VMapper-10 Unit Main TLCI Screen

Function Key	Description
F1	On-Line Help – provides definition and explanation of some of the fields used in this screen.
F3	Used to enter the configuration mode. The first programmable field is highlighted. The up and down arrow keys may be used to go through different fields. F5 is used to edit the fields. The left and right arrow keys may be used to display different options.
F4	Toggles the mode of the Usage field (shows bandwidth usage in Mb/s or in %).
F6	Resets the unit error counters to zero for the six ports on the VMapper-10 unit.
F7	Displays the unit serial number and firmware version.
F8	Displays the status, BER and error count for each assigned slot on both TIFports.
F9	Displays the TU-11 Information Screen (see Maintenance and Troubleshooting section).

Table 5: Function Keys in TLCI Screen

STATUS

May be set to Assigned (port is used) or Unassigned (port is unused) for each of the six ports on the VMapper-10 unit.

Note, at a ring node or add/drop node in a linear system, both TIFports are connected to the respective STM-1 Aggregate/TUG-3 units and assigned. At a terminal node, right port is not connected and not assigned.

During normal operation, this field indicates the status of each assigned port on the VMapper-10 unit.

Following are the possible display values for TIFports (shown in priority order):

- Clock fail – TIFport not connected to STM-1 Aggregate (or TUG-3) unit;
- AIS – Path AIS detected;
- BIP-2 (B4) BER – TU-1 path bit error rate exceeds threshold;
- Bad V5 label – V5 label bits are not "1X1";
- No link – Normal and OK for the right TIFport port of a VMapper-10 unit configured as Ring Closer unit, and left TIFport of the VMapper-10 unit to the right of the Ring Closer unit in the video network;
- Yellow – Far-end VMapper-10 unit is in alarm;
- Dupl-Hello – VNA#s are not unique in the video system.

Following are the possible display values for Vports (shown in priority order):

- LOS – no signal detected at this Vport;
- BER – an excessive bit error rate at this Vport;
- Dupl-Hello – VNA#s are not unique in the video system;
- No Hairpin – valid VMapper-10 to VMapper-10/40 link;
- ALARM – Alarm state of the unit connected to the Vport;
- ALERT – Alert state of the unit connected to the Vport.

ERRORS (Not Adjustable)

Displays the current bit error rate and cumulative count of errors detected for the assigned ports on the VMapper-10 unit.

<F6> "Clear Counters" resets internal counters to zero for all six ports.

USAGE (Not Adjustable)

Displays the current usage of the bandwidth for each assigned port, for both IN and OUT directions. The bandwidth usage is displayed either in Mb/s or as a percentage of the port's capacity. F4 key toggles the mode. Ideally the network loading should be set so that the bandwidth usage for any port is below 90%.

TEST

This is a built in test feature allowing a user selectable test pattern to be sent in the TU-11 payloads between nodes. This pattern may be either the same for all assigned TIF slots (user selectable from '11' to 'FE') or a sequence ('11' for slot #1, '22' for slot #2,..., '77' for slot #7). By monitoring the incoming TU-11 at the remote site, validity of the TU-11 path can be confirmed. This TU-11 path testing checks the integrity of the path between adjacent VMapper-10 units. Note that a TU-11 test will kill the normal video traffic on the TU-11 path.

V5 LBL (Not Adjustable)

Indicates the content of the VC-11 signal label in outgoing and incoming TU-11s on both TIFports.

The VC-1 signal label in the V5 byte of the VC-1 path overhead is used to determine the health of the ring. Normally the label '5' should be seen at the "IN" and "OUT" for both TIFports at all VMapper-10 units in the ring. If this is not the case, a break in the ring has occurred and a path protection switch is initiated.

In a linear system, the reading in these fields should be '7' in all VMapper-10 units.

Symbol '-' in a V5 LBL field indicates TU-1 Path AIS (V5 = 'FF') and "AIS" is displayed in the Status field.

SLOTS ASSIGNED

Displays which of the 7 slots in each TIFport are being used by this unit. Each slot can be either assigned or unassigned (-). Both left and right VMapper-10 unit's TIFports must be configured identically at an add/drop node.

Note that the same set of (up to seven) TU-1s must be dropped on each VMapper-10 unit in the network (same ring or linear system).

For each assigned Vport, the identity of the connected unit is displayed (Video I/O, VMapper-10 or VMapper-40).

SOURCE (Not Adjustable)

Displays the ring number and node number of the node that the STM-1 Aggregate unit(s) belongs to. Also, the TIFport(s) on the STM-1 Aggregate/TUG-3 unit(s) that this VMapper-10 unit is connected to is specified in the form of a 3-character value. L/R designates the Left/Right STM-1 Aggregate/TUG-3 unit, X/Y/Z designates the type of the unit that the VMapper-10 unit's TIFport is connected to (X for STM-1 Aggregate unit, Y/Z for TUG-3 unit), and 1/2/3 designates the exact TIFport on the STM-1 Aggregate/TUG-3 unit that the VMapper-10 unit is connected to.

Setup

VNA

Each VMapper unit has its own unique Video Network Address (VNA). A VNA address for a VMapper unit is in the range 1 – 511 and is always displayed with the letter "m" preceding the number.

TYPE

In a ring configuration, one and only one VMapper-10 unit must be configured for "Ring Closer". All other units in the ring must be configured as "Normal". The VMapper-10 unit configured for "Ring Closer" is responsible for initiating the path protection switch if a break in the ring is detected. Note that under normal conditions (no ring failures) the Ring Closer node is not supporting any traffic on its Right TIFport.

In a linear configuration, all VMapper-10 units are configured for "Normal".

B4 BER THRESHOLD

VC-11 Path BER threshold setting. An alarm condition is reported if the threshold setting is exceeded in any of the assigned slots (TU-11s).

RACK NUMBER (use is optional)

Identifies rack or cabinet in which the unit is located. This information may be utilized on the NMS (Network Management System).

RACK MOUNT POSITION (use is optional)

Identifies location of shelf in which the unit is located. This information may be utilized on the NMS.

SHELF SLOT POSITION (use is optional)

Identifies slot position within the shelf (1 through 15) in which the unit is located. This information may be utilized on the NMS.

VMAPPER SYNC MODE

In TN1U video applications this field is set to Normal. In Video LAN applications (not requiring SDH links), one VMapper-10 unit in each Video LAN is configured to Internal.

Monitor

TOTAL VMAPPERS (Not Adjustable)

Displays the total number of VMapper units visible to this unit. In normal operating systems this number corresponds to the total number of VMapper units in the TN1U system. It is normal for changes in the system to be updated after three to four minutes.

TOTAL VIDEO I/O (Not Adjustable)

Displays the total number of Video I/O units visible to this unit. In normal operating systems this number corresponds to the total number of Video I/O units in the TN1U system. It is normal for changes in the system to be updated after three to four minutes.

UNIT TEMP (Not Adjustable)

Displays the average temperature within the VMapper-10 unit with a $\pm 2^{\circ}$ C accuracy. Normally the reading is about 15° C above ambient.

PLL VOLTS (Not Adjustable)

The VMapper-10 unit uses a Phase Lock Loop (PLL) to synchronize its rate to that of the SDH system. The PLL voltage controls a VCXO to obtain a synchronous clock. The PLL voltage is normally 1.2 ± 0.4 V. The VMapper-10 unit will alarm when this voltage is < 0.8 V and > 2.5 V.

PADDLEBOARD ID (Not Adjustable)

This field identifies the type of the paddleboard present. The type of paddleboard is detected by means of a resistor divider feeding the units A-D converter on its main board.

EXPANSION (Not Adjustable)

Consists of two fields. The one to the right of the single vertical line is associated with the 86411-9X paddleboard's J2 slot while the one to the left is associated with the 86411-97 paddleboard's J3 slot. Possible readings are:

- '—' Vport-F unit NOT installed in the respective slot.
- '86413-01' A single-port Vport-F unit is installed in the respective slot.
- '86413-02-1' A dual-port Vport-F unit is installed in the respective slot and its second Vport is disabled.
- '86413-02-2' A dual-port Vport-F unit is installed in the respective slot and its second Vport is enabled.
- <blank> The field associated with J3 slot is blanked out when 86411-96 paddleboard is present (J3 slot is not applicable for this paddleboard).

VPORTS 4-1 (Not Adjustable)

Indicates the type of the Vport connection for each of the four Vports. Displays RJ45 for an electrical Vport or FIBRE for an optical one.

RING HEALTH

Ring Health uses the F2 byte to determine if the ring is OK or broken.

TU-11 Errors Screen

Pressing the F8 key in the main screen brings up a screen with status, BER and error count information for all assigned TIFslots (TU-11s) on both TIFports (Figure 9).

SL #, TU-1# (Not Adjustable)

There are seven available slots (1 to 7) to a TIFport. Each slot can be either assigned or unassigned (in the unit's main TLCI screen). In this screen, the TU-1#s assigned to these slots in the STM-1 Aggregate/TUG-3 unit are displayed.

STATUS (Not Adjustable)

Displays the status of the TU-11s received in all assigned TIFport slots. An "OK" indicates a healthy TU-11 signal.

LENTRONICS		TN1U LOCAL CRAFT INTERFACE PROGRAM				UER-2.17	
86411 VMAPPER-10						S/N 01-01-0000	
LEFT			TEST				
SL#	TU#	STATUS	XMT-RCV	BER-LOC-COUNT	BER-FAREND-COUNT	YELLOW	
1	8	OK	-	< 1 ppm < 0>	< 1 ppm < 0>	-	
2	9	OK	-	< 1 ppm < 0>	< 1 ppm < 0>	-	
3	10	OK	-	< 1 ppm < 0>	< 1 ppm < 0>	-	
4	11	OK	-	< 1 ppm < 0>	< 1 ppm < 0>	-	
5	12	OK	-	< 1 ppm < 0>	< 1 ppm < 0>	-	
6	13	OK	-	< 1 ppm < 0>	< 1 ppm < 0>	-	
7	14	OK	-	< 1 ppm < 0>	< 1 ppm < 0>	-	
RIGHT			TEST				
SL#	TU#	STATUS	XMT-RCV	BER-LOC-COUNT	BER-FAREND-COUNT	YELLOW	
1	8	OK	-	< 1 ppm < 0>	< 1 ppm < 0>	-	
2	9	OK	-	< 1 ppm < 0>	< 1 ppm < 0>	-	
3	10	OK	-	< 1 ppm < 0>	< 1 ppm < 0>	-	
4	11	OK	-	< 1 ppm < 0>	< 1 ppm < 0>	-	
5	12	OK	-	< 1 ppm < 0>	< 1 ppm < 0>	-	
6	13	OK	-	< 1 ppm < 0>	< 1 ppm < 0>	-	
7	14	OK	-	< 1 ppm < 0>	< 1 ppm < 0>	-	
F1: HELP		F6: Clr Counts		F9: TU-TABLE		F10: Return	
Esc-EXIT							

Figure 9: "F8" TU-11 Errors Screen

Function Key	Description
F1	On-Line Help – provides definition and explanation of some of the fields used in this screen.
F6	Resets the unit error counters to zero for the six ports on the VMapper-10 unit.
F9	Displays the TU-11 Information Screen (see Maintenance and Troubleshooting section).
F10	Return to the Main Screen

Table 6: Function Keys in "F8" TU-1 Errors Screen

TEST XMT-RCV (Not Adjustable)

Displays the transmitted and received test patterns in all assigned TIF slots (TU-11s).

BER-LOC-COUNT (Not Adjustable)

Displays the current bit error rate and count of errors for all assigned TIFport slots. Uses the Path BIP-2 bits (B4).
 <F6> "Clear Counters" resets the unit counters to zero.

BER-FAREND-COUNT (Not Adjustable)

Displays the current BER rate of the remote VMapper-10 unit.

YELLOW (Not Adjustable)

Indicates the detection of a yellow path alarm which will also be displayed on the front of the unit. (This is generated by the remote VMapper-10 unit when it is receiving a bad TU-11.)

7. MAINTENANCE and TROUBLESHOOTING

F1 Help

The "F1" key is a useful tool for explaining the capabilities and options of both programmable fields and display fields of the unit. The user selects "F1" from the TLCI screen and then chooses the topic he/she wishes information on.

Configuration

The 86411-01 VMapper-10 unit must be correctly configured as per the Node Assignment Drawing. All software adjustable fields are detailed in the Configuration Section of this manual. The user must ensure that all external connections to the paddleboard are correct.

Key Fields to Monitor using TLCI/TNCI program

Field	Typical Range	Cause for Concern
PLL Voltage	1.2 ± 0.4 V.	<0.8V and >2.0V.
Temperature	15° C above ambient.	Excessive high temperature.
Total VMappers	Must correspond to the number of all VMapper units in the system. Displayed count includes this unit.	If different, use Dumb Terminal (Z7A and Z7) commands to identify the cause of problem.
Total Video I/O	Must correspond to the number of all Video I/O units in the system per designer's intent.	If different, use Dumb Terminal (Z7A) commands to identify the cause of problem.

Table 7: Key Fields to Monitor

TU-Table Screen

Figure 10 is the TU-Table screen that is displayed when the "F9" key is selected from the VMapper-10 Unit Main TLCI Screen or from the "F8" TU-11 Errors TLCI screen.

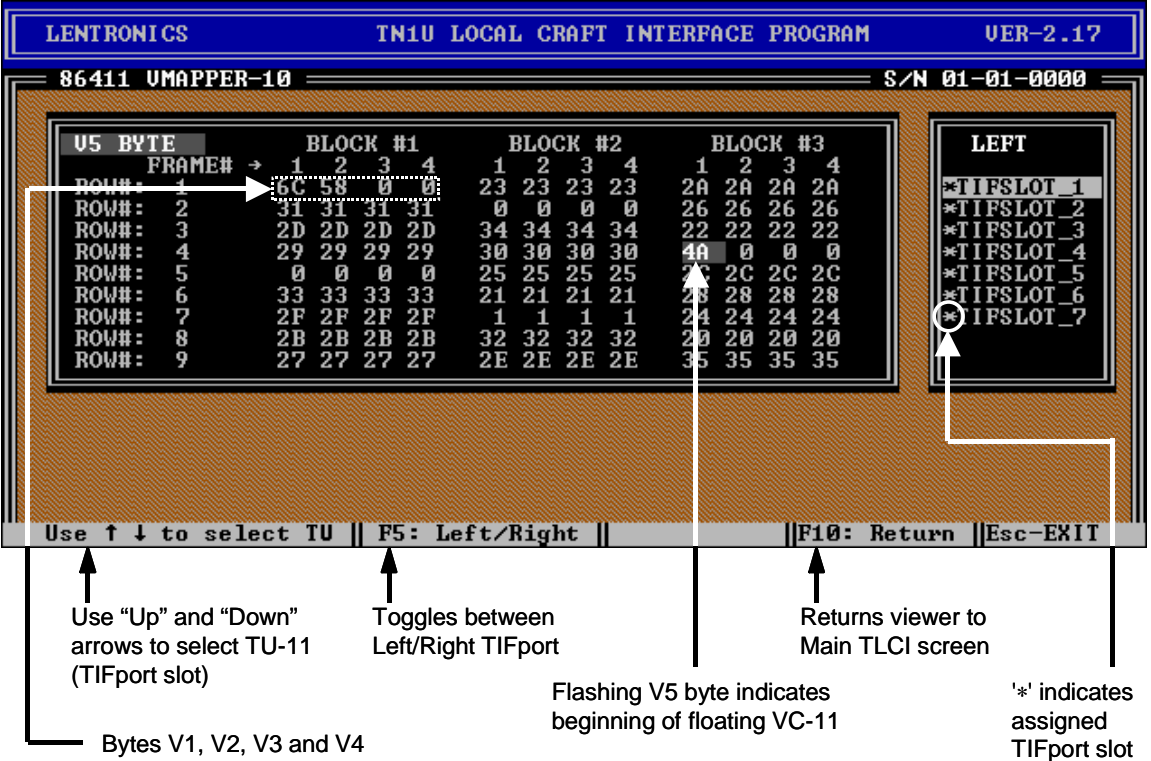

Figure 10: "F9" TU-Table Screen

The TU-Table screen is a maintenance tool which allows the viewer to inspect the traffic in all seven TIFport slots (TU-11s). The screen displays 3 blocks with each block comprising 9 rows and 4 frames per row. The 3 blocks comprise TU-11 superframe information.

The first 4 frames in row #1 consist of bytes V1, V2, V3 and V4. The V1 byte has a fixed value and should always be "6C". Byte V2 is the TU-1 pointer byte which determines the location of byte V5 which in turn is displayed on the screen as the only 'flashing' byte. V5 is part of the VC-1 path overhead and denotes the beginning of the 104-byte VC-11.

The location of the V5 byte may vary from one unit to another (depending on the present TU-11 pointer value carried in the byte V2). This location as denoted by the flashing byte can also be calculated by converting the value of byte V2 from hex to its decimal equivalent and overlaying this value with the TU-11 Display Mask supplied in Table 7.

The VC-1 signal label in the V5 byte of the VC-1 path overhead is used to determine the health of the ring. In a ring system, during normal operating conditions the V5 byte value will always end with 'A'. If this is not the case, a break in the ring has occurred and a path protection switch is initiated. In a linear system, V5 byte normally ends with 'E'.

Table 7 shows all the offset positions of the V5 byte in decimal, from V2, as displayed by the TLCI TU-Table command.

	Block 1					Block 2					Block 3			
	Frame					Frame					Frame			
	1	2	3	4		1	2	3	4		1	2	3	4
Row #1	V1	V2	V3	V4		78	0	26	52		79	1	27	53
Row #2	80	2	28	54		81	3	29	55		82	4	30	56
Row #3	83	5	31	57		84	6	32	58		85	7	33	59
Row #4	86	8	34	60		87	9	35	61		88	10	36	62
Row #5	89	11	37	63		90	12	38	64		91	13	39	65
Row #6	92	14	40	66		93	15	41	67		94	16	42	68
Row #7	95	17	43	69		96	18	44	70		97	19	45	71
Row #8	98	20	46	72		99	21	47	73		100	22	48	74
Row #9	101	23	49	75		102	24	50	76		103	25	51	77

Table 8: V5 Offset Position Table

TU-11 Path Testing

A built-in test and monitoring capability allows for the insertion of a "TEST-TU" into all outgoing TU-11s. This sets 100 data bytes (C-11) in each TU-11 multiframe to a user selectable pattern. This pattern may be either the same for all assigned TIFport slots (user selectable from '11' to 'FE') or a sequence ('11' for slot #1, '22' for slot #2,... '77' for slot #7). By monitoring the incoming TU-1 at the remote site, validity of the TU-11 path can be confirmed. This TU-11 path testing checks the integrity of the path between adjacent VMapper-10 units and is performed through the TLCI or TNCI software.

Troubleshooting

If an 86411-01 VMapper-10 unit is suspected of being defective, substitute it for a known-good 86411-01 unit and if the unit functions properly return the original to GE Power Management for repair or replacement. Ensure that the substitute unit is configured correctly. For unit replacement procedure, refer to the procedure *Replacing a VMapper-10 Unit in a System in Service* in the Installation section.

The following table is intended to provide the user with possible solutions to problems that may be encountered during normal unit operation.

Symptom	Probable Cause / Solution
L or R red LED steady on	<ul style="list-style-type: none"> - Ensure that STM-1 Aggregate units (or TUG-3 units) are not in alarm. - Verify that Add and Drop configuration is correct per the Node Assignment Drawing. <ul style="list-style-type: none"> - Verify that VMapper-10 unit's TIFports are physically connected to proper TIFports on the STM-1 Aggregate (or TUG-3) units. - Verify that the used TIFports and Vports are "Assigned" in the VMapper-10 units. - Verify that proper TU-1s are dropped on proper slots on (both) TIFport(s) - Verify proper TSI configuration in STM-1 Aggregate units. - Check the alarm reported in the Status field of the TLCI screen and do the following: <ul style="list-style-type: none"> - "AIS", "BAD BER" – Check all hops on TU-1 path; - "BAD LABEL" – Check whether the far-end unit is a VMapper-10 unit. - Verify the correct configuration of other VMapper units in the system. - Ensure that TU-11 path is correct. Use "Test TU" feature to verify end-to-end path integrity.
L or R yellow steady on	<ul style="list-style-type: none"> - Indicates that the far-end VMapper-10 unit is receiving an abnormal TU-11 signal. The respective far-end unit's TIFport Red LED is steady on.
L or R yellow and red LEDs flashing	<ul style="list-style-type: none"> - Indicates a loss of clock from the STM-1 Aggregate (or TUG-3) unit. Check the TIFport connection.

ALARM LED steady on	<ul style="list-style-type: none"> - Indicates one of the following. Check the alarm reported in the TLCI screen. <ul style="list-style-type: none"> - Paddleboard is missing - Verify that the main paddleboard is present. - Paddleboard's lower sub-board is missing - VCXO control voltage is out of range. The VCXO voltage should be in the range $1.2V \pm 0.4V$. - Unit temperature is excessive - an alarm is generated if the unit temperature exceeds 93°C. - FPGA (Xilinx) did not boot - Replace the unit - Vport is configured for "assigned" but is receiving a bad signal (either LOW-LEVEL or HIGH BER). Verify that the cable connecting the Vport on the Vmapper-10 unit to the Video I/O unit or another Vmapper-10 unit is OK. Use another (unused) Vport on the VMapper-10 unit and the Video I/O unit to confirm that the Vports on the respective units are not defective.
ALARM LED flashing	<ul style="list-style-type: none"> - Occurs when the conditions under "ALARM LED Steady ON" are OK and one of the following conditions exists: <ul style="list-style-type: none"> - Video I/O unit is in alarm. See Video-I/O unit troubleshooting. - Unit is receiving duplicate "Hello" packets – at least two (of the six) ports are receiving "Hello" packets with the same VNA# address. Verify that each VMapper-10 unit or Video I/O unit is assigned a unique VNA# address; in a ring system verify that one VMapper-10 unit is configured for "Ring Closer". Use Z7A and Z7B commands (see Dumb Terminal Mode).

Table 9: Troubleshooting Table

Dumb Terminal Mode

The standard TLCI program provides the necessary information to the user to locate problems; however, the user may use commands in the Dumb Terminal Mode to get more information on the status of the unit or the operation of the system. To enter the Dumb Terminal mode and communicate directly with the microprocessor at the DOS Prompt, run Access program.

To establish a Dumb Terminal session

1. Connect the TLCI cable to the craft interface port on the VMapper-10 unit
2. At the DOS Prompt type *cd TLCI* (or enter the directory in which Access program resides)

3. Type *ACCESS*
4. Enter <return>
5. Receive a confirmation that a connection is established
6. Enter <return>
7. Receive the prompt *ok*

The following table lists some of the commands used in Access program.

Command	Displays
Z	The first 10 rows show the detailed status of each of the 7 TIFport slots for both TIFports. This can be useful for determining which of the slots is responsible for a problem, e.g. BAD-BER. JIFPORTIDS shows the port #, ring #, and node # for the left and right TIFports. JMUX/VT# shows the TU-1s assigned to the slots (in the STM-1 Aggregate or TUG-3 units). VFLAGS shows the NMS bytes being returned for NMS requests.
Z1	Displays the unit's VNA# assignment, the TIFport assignments, the TIFport neighbours' VNA#s (unless it is the right port of a Ring Closer unit in which case FFFF is received), if link packets are not being received, if the unit is configured as a Ring Closer unit and its status, the TIFports' received signal status (BER, AIS), the test bytes, number of alive units detected.
Z2	Displays the Vport assignments, if an assigned and functioning port has its "hairpinning" disabled, the Vport received signal's status (BER and LOW LEVEL), the Video I/O unit in alarm.
Z3	Five used ADC signal levels and if in alarm.
Z4	Incoming and outgoing idle rates on all six ports.
Z6	Last message received by the unit. Last link packets received on each unit's port.
Z7	The VNA# table for the first 128 Video I/O units and the first 64 VMapper-10 units. See interpretation of the Z7 command for more information.
Z7A	The VNA#s (hex) with non-zero entries (scans all 8192 entries in the table).
<VNA# (hex)> Z7B	The "Hello" source port, and all the "Wanted" exit ports, for the specified VNA#.

Table 10: Dumb Terminal Commands

Interpretation of the Z7 Command

The Z7 command displays the VNA# table for the first 128 Video I/O units, and the first 64 VMapper-10 units (excluding the local unit). This display is updated once a minute. A non-zero entry means that the unit is receiving "Hello" packets for that VNA#.

8. UNIT PARAMETERS

TIFport (Full Duplex)

Connector:	8-pin Paddleboard Connector
Data:	12.96 Mb/sec (serial data)
Packet Rate:	8k packets/sec per TU-1 (56k packets/sec when 7 slots assigned)
Packet Size:	25 bytes
Packet Bit Rate:	1.6 Mb/sec per TU-1 11.2 Mb/sec (when 7 slots assigned)
Input Packet Buffer:	1024 packets (16 ms)
Output Packet "TODO" List Buffer:	4096 packets (64 ms)

Vport (Full Duplex)

Connector:	RJ45 Connector
Cable type:	CAT 5 (8 conductor)
Cable Max. Length:	50' or 15m
Line Rate:	16.2 MHz
Format:	Serial Bits
Coding Format:	5B:4B
Data Bit Rate:	12.96 Mb/s
Packet Bit Rate:	12.8 Mb/s

Frame Rate:	8 kHz
Packet Rate:	64k packet/sec
Packet Size:	25 bytes
Input Packet Buffer:	256 packets (4ms)
Output Packet "TODO" List Buffer:	4096 packets (64ms)
VNA# Table	4095 entries

Accuracy of Performance Monitors

B3 Error Rate:	$\pm 20\%$
Vport Error Rate:	$\pm 20\%$
PLL Voltage Monitor:	$\pm 5\%$

9. SPECIFICATIONS

Physical

The VMapper-10 unit is housed in either TN1U shelf (Common or Expansion) and occupies a single shelf slot with the following dimensions:

- 1) Height: 89 mm (3.5 inches)
- 2) Width: 29 mm (1.135 inches)
- 3) Depth: 203 mm (8 inches)
- 4) Weight: 150 grams (5 oz)

Electrical

The input power requirements for the VMapper-10 unit are:

- 1) Voltage: 5.2 VDC \pm 5%
- 2) Current: 450 mA (max)
- 3) Power Consumption: 2.4 W (max), 2.1 W (typical)

This voltage is supplied from the 86430 Equipment Shelf.

Environmental

- 1) Temperature:
 - Guaranteed Performance: -10 to +60°C (+14 to +140°F)
 - Storage: -40 to +70°C (-40 to +158°F)
- 2) Relative Humidity: 5 to 95% @ 40°C, non-condensing, 10 days
- 3) Shipping Altitude: 15,000 meters (50,000 feet)

Mechanical

- 1) Vibration: per MIL-STD 810E
- 2) Bench Handling: per TS 1-00446.06

RFI

Meets ANSI/IEEE C37.90.2

Reliability

The calculated Mean Time Between Failure (MTBF) as per Bell technical advisory TR-NWT-000332 for the VMapper-10 unit is:

$$\text{MTBF} = 224,256 \text{ Hours (25.6 Years)}$$

10. ORDERING INFORMATION

This section covers the ordering information for a single 86411 VMapper-10 unit and is not intended to replace standard engineering documentation or drawings.

Please contact the Account Manager for your area regarding ordering the 86411 VMapper-10 unit.

Equipment and Option Code List

Equipment	Option Code	Description
86411	-01	Provides the interface between an STM-1 Aggregate (or TUG-3) unit's TIFport and up to four Video I/O units. Used with either 86411-96 or 86411-97 paddleboard assembly.
86411	-96	Paddleboard Assembly. Provides connections for one to four Vports using standard CAT 5 (RJ45) copper cables. Also supports one 86413-0X Vport-F unit (installed in its J2 slot) for fibre links for Vport #1 and optionally for Vport #2.
86411	-97	Paddleboard Assembly. Provides same functions as 86411-96 but supports a second 86413-0X Vport-F unit (installed in its J3 slot) for fibre links for Vport #3 and optionally Vport #4.

Table 11: Equipment and Option Code Table

APPENDIX A

86411-90 PADDLEBOARD CONNECTIONS

The 86411-90 is a “legacy” paddleboard (discontinued in November 2001) but is still in use in some customer systems.

The VMapper-10 Paddleboard Assembly (two shelf-slots wide) consists of the main paddleboard and either one or two sub-boards (Code A). Each sub-board has two Vports (RJ45). The Vports are labelled "DOWN". Each Vport provides a data link to a Vport labelled "UP" on a Video I/O unit Paddleboard or to a Vport labelled "DOWN" on another VMapper unit Paddleboard. If only one sub-board is used then it should be mounted in the lower position on the main paddleboard.

Note: *If the main paddleboard's lower position is not equipped with a Code A sub-board, the local Video I/O unit is in alarm (steady red LED on).*

When connecting a VMapper-10 unit to a Video I/O unit, the Vport "DOWN" on the VMapper-10 unit is connected to the Vport "UP" on the Video I/O unit using a straight-through CAT 5 cable. For this purpose, cables 135-86411-01 (30 cm), 135-86411-02 (60 cm), 135-86411-03 (90 cm), 135-86411-04 (1.2 m) or 135-86411-05 (1.5 m) are used. The cable selection depends on the distance between the VMapper-10 unit and respective Video I/O unit.

To connect the Vports on two VMapper units, the Vport "DOWN" on one VMapper unit is connected to the Vport "DOWN" on the other VMapper unit using a crossover CAT 5 cable. For this purpose, cables 135-86411-06 (1 m), 135-86411-07 (3 m), or 135-86411-08 (6 m) are used. The cable selection depends on the distance between the two VMapper units.

The Figure below details the paddleboard connections.

WARNING

For correct operation, the CBUS Jumper 087-86430-90 must not be installed underneath nor on either side of the VMapper-10 unit Paddleboard.

**86410-90 VMapper-10
 Paddleboard Assembly
 (Shown without codes installed)**

From Right STM-1
 Aggregate (or TUG-3) unit
 TIFport via 035-86430-68
 cable assembly or from
 "RIGHT TIF OUT" port of
 CMUX, Ethernet, FDM, or
 another VMapper-10 unit
 Paddleboard via 035-
 86430-20 cable assembly
 (cascading).

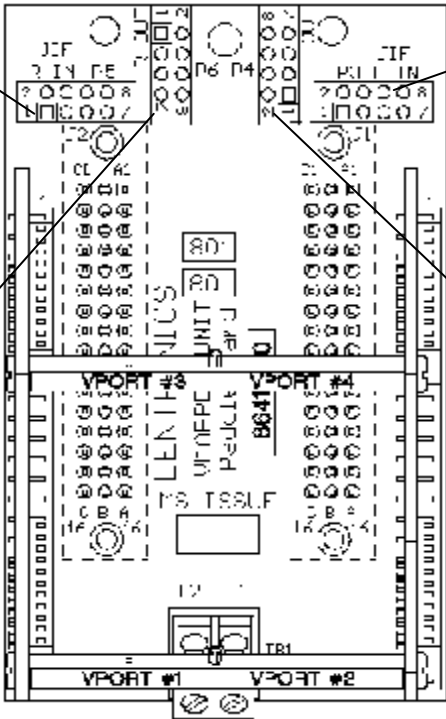

From Left STM-1 Aggregate
 (or TUG-3) unit TIFport via
 035-86430-67 cable
 assembly or from "LEFT TIF
 OUT" port of CMUX,
 Ethernet, FDM, or another
 VMapper-10 Paddleboard via
 035-86430-20 cable
 assembly (cascading).

Extends the Right
 TIFport to "RIGHT TIF
 IN" port of CMUX,
 Ethernet, FDM, or
 another VMapper-10
 unit Paddleboard when
 additional TU-11s are
 to be dropped from the
 same TIF port.

Extends the Left
 TIFport to "LEFT TIF
 IN" port of CMUX,
 Ethernet, FDM, or
 another VMapper-10
 unit Paddleboard when
 additional TU-11s are
 to be dropped from the
 same TIF port.

**Code A Paddleboard Assembly
 Dual RJ45 Port Interface**

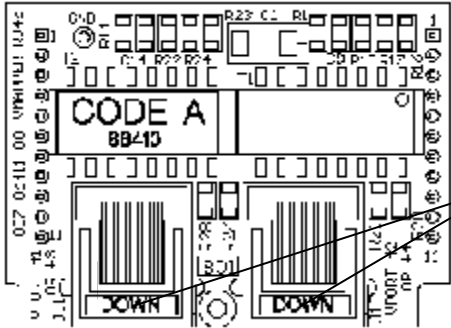

Vports (DOWN)
 (CAT 5 cable)

APPENDIX B

LIST OF ILLUSTRATIONS

List of Figures

FIGURE	DESCRIPTION	PAGE
Figure 1:	TN1U Video WAN	9
Figure 2:	Front Panel Layout	11
Figure 3:	VMapper-10 Unit Functional Block Diagram.....	21
Figure 4:	Typical Rack Layout	24
Figure 5:	VMapper-10 Paddleboards.....	26
Figure 6:	Example of TU-1s dropped on an unused TIFport	29
Figure 7:	Example of TU-1s dropped on a TIFport not fully utilized	31
Figure 8:	VMapper-10 Unit Main TLCl Screen	35
Figure 9:	"F8" TU-11 Errors Screen.....	41
Figure 10:	"F9" TU-Table Screen	44

List of Tables

TABLE	DESCRIPTION	PAGE
Table 1:	Video Traffic Pattern.....	10
Table 2:	Unused Bandwidth between Nodes	10
Table 3:	Packet Types.....	18
Table 4:	Paddleboard Usage.....	25
Table 5:	Function Keys in TLCl Screen.....	35
Table 6:	Function Keys in "F8" TU-1 Errors Screen	41
Table 7:	Key Fields to Monitor	43
Table 8:	V5 Offset Position Table.....	45
Table 9:	Troubleshooting Table.....	47
Table 10:	Dumb Terminal Commands.....	48
Table 11:	Equipment and Option Code Table	54

APPENDIX C

LIST OF ACRONYMS

- ACK Acknowledge
- A-D Analogue to Digital
- ADC Analogue-to-Digital Converter
- AIS Alarm Indication Signal
- ANSI American National Standards Institute
- BER Bit Error Rate
- BIP Bit Interleaved Parity
- C Container
- CBUS Channel Bus
- CPU Central Processing Unit
- CI Craft Interface
- CPU Central Processing Unit
- DC Direct Current
- DOS Disk Operating System
- EAS Electronic Assembly Schematic
- EIA Electronic Industries Association
- EMI Electromagnetic Interference
- ESDS Electro Static Discharge Sensitive
- FPGA Field Programmable Logic Gate Array
- IEEE Institute of Electrical and Electronics Engineers
- I/O Input/Output
- LAN Local Area Network
- LED Light Emitting Diode
- LOS Loss Of Signal

APPENDIX C

LIST OF ACRONYMS (CONTINUED)

- MTBF Mean Time Between Failures
- NAD Node Assignment Drawing
- NMS Network Management System
- PC Personal Computer
- PLL Phase Locked Loop
- POH Path Overhead
- PSA Packet Start Address
- RAM Random Access Memory
- RCV Receive
- RFI Radio Frequency Immunity
- ROM Read-Only Memory
- SDH Synchronous Digital Hierarchy
- SRAM Static Random Access Memory
- STM Synchronous Transport Module
- TLCI TN1U Local Craft Interface
- TIF TN1U Intermediate Format
- TNCI TN1U Network Craft Interface
- TPIM Technical Practice and Installation Manual
- TU Tributary Unit
- TUG Tributary Unit Group
- VCXO Voltage Controlled Crystal Oscillator
- VC Virtual Container
- VNA Video Network Address
- WAN Wide Area Network
- XMT Transmit